

Symposium Organized by the  
Wooden Artifacts Group of  
the American Institute for  
Conservation of Historic and  
Artistic Works

Williamsburg, Virginia  
November 1994

# Painted Wood: History and Conservation



# Painted Wood: History and Conservation

Proceedings of a symposium organized by the  
Wooden Artifacts Group of the American Institute  
for Conservation of Historic and Artistic Works  
and the Foundation of the AIC, held at the Colonial  
Williamsburg Foundation

Williamsburg, Virginia  
11–14 November 1994

*Edited by Valerie Dorge and F. Carey Howlett*

THE GETTY CONSERVATION INSTITUTE  
LOS ANGELES

Cover: Detail, polychrome tester bedstead (ca. 1580–1630) from Burderop House, Wiltshire, England, now at Agecroft Hall, Richmond, Virginia. Photo courtesy of the Agecroft Association.

Dinah Berland, *Managing Editor*  
Nomi Kleinmuntz, *Copy Editor*  
Anita Keys, *Production Coordinator*  
Jeffrey Cohen, *Series Designer*  
Hespenheide Design, *Book Designer*

Printed in Singapore

10 9 8 7 6 5 4 3 2 1

© 1998 by The J. Paul Getty Trust  
All rights reserved.

The Getty Conservation Institute works internationally to further the appreciation and preservation of the world's cultural heritage for the enrichment and use of present and future generations. The Institute is an operating program of the J. Paul Getty Trust.

The Getty Conservation Institute gratefully acknowledges the generous contribution of the Polly M. Stone 1992 Trust toward the color printing of this publication.

The listing of product names and suppliers in this book is provided for information purposes only and is not intended as an endorsement by the Getty Conservation Institute.

Library of Congress Cataloging-in-Publication Data

Painted wood : history & conservation / edited by Valerie Dorge and F. Carey Howlett.  
p. cm.

Proceedings of a symposium organized by the Wooden Artifacts Group of the American Institute for Conservation of Historic and Artistic Works, held in Williamsburg, Va., 11–14 Nov. 1994.

Includes bibliographical references.

ISBN 0-89236-501-3

1. Painted woodwork—Conservation and restoration—Congresses. 2. Painted furniture—Conservation and restoration—Congresses. I. Dorge, Valerie, 1946–. II. Howlett, F. Carey, 1950–. III. American Institute for Conservation of Historic and Artistic Works. Wooden Artifacts Group.

NK9604.5.P35 1998  
745.7'2'0288—dc21

97-36527  
CIP

# Contents

*Miguel Angel Corzo*      vii      Foreword

*Valerie Dorge*      viii      Preface  
*F. Carey Howlett*

## PART ONE

### **Understanding and Identifying Materials**

*R. Bruce Hoadley*      2      Wood as a Physical Surface for Paint Application

*David Erhardt*      17      Paints Based on Drying-Oil Media

*Richard Newman*      33      Tempera and Other Nondrying-Oil Media

*James S. Martin*      64      Microscopic Examination and Analysis of the Structure  
and Composition of Paint and Varnish Layers

## PART TWO

### **Historical Perspectives**

*Myriam Serck-Dewaide*      82      Support and Polychromy of Altarpieces from Brussels,  
Mechlin, and Antwerp  
*Study, Comparison, and Restoration*

*Nancie C. Ravenel*      100      Painted Italian Picture Frames in the Samuel H. Kress  
Foundation Collection at the National Gallery of Art

*Ian C. Bristow*      110      The Imitation of Natural Materials in  
Architectural Interiors

*James Yorke*      120      Royal Painted Furniture in King Charles I's England

*Elizabeth White*      128      Perished Perches: The Evidence for English Painted  
Wooden Furniture in Eighteenth-Century Gardens

*Susan L. Buck* 143 Shaker Painted Furniture  
*Provocative Insights into Shaker Paints  
and Painting Techniques*

PART THREE

**Historical Materials and Techniques**

*Hans Portsteffen* 156 Form and Polychromy: Two Different Concepts  
in One Object  
*Notes on Seventeenth-Century Sculpture Workshop Practices  
in Bavaria*

*Renate Gold* 166 Reconstruction and Analysis of Bismuth Painting

*Margaret J. Ballardie* 179 Japanning in Seventeenth- and Eighteenth-Century  
Europe  
*A Brief Discussion of Some Materials and Methods*

*Laurence Libin* 186 Painted Harpsichords

*Frances Gruber Safford* 194 Floral Painting on Early Eighteenth-Century American  
Furniture at The Metropolitan Museum of Art

*Luiz A. C. Souza* 206 Chinese Motifs in the Baroque Art of Minas Gerais,  
*Cristina Avila* Brazil  
*Historical and Technical Aspects*

*Chris A. Shelton* 217 A Short Primer on the White-Painted Furnishings of  
Eighteenth-Century Philadelphia

*Jonathan Thornton* 226 The Use of Dyes and Colored Varnishes in  
Wood Polychromy

*Robert D. Mussey Jr.* 242 Verte Antique Decoration on American Furniture  
*History, Materials, Techniques, Technical Investigations*

*Nancy N. Odegaard* 255 An Investigation of the Nature of Paint on Wood  
Objects in the Indigenous Southwest of North America

*Mark A. Harpainter* 268 The Painted Furniture and Wooden Decorative Arts of  
*Christopher C. Augerson* Lucia and Arthur Mathews

PART FOUR

**Investigations and Treatment**

*Michele D. Marincola* 278 Monochromy, Polychromy, and Authenticity  
*Jack Soutanian* *The Cloisters' Standing Bishop Attributed to  
Tilman Riemenschneider*

<i>Anna C. Hulbert</i>	287	Conservation of the Fourteenth-Century Ceiling at Saint Helen's Church, Abingdon
<i>Claude Payer</i> <i>Marie-Claude Corbeil</i> <i>Colombe Harvey</i> <i>Elizabeth Moffatt</i>	301	The Interior Decor of the Ursuline Chapel in Quebec City <i>Research and Conservation</i>
<i>Elizabeth Howard Schmidt</i>	318	The Painted Tester Bedstead at Agecroft Hall
<i>Marianne Webb</i>	328	Four Japanned Cabinets: A Variety of Techniques
<i>Andrea M. Gilmore</i>	337	The Hunnewell Cottage <i>Preservation and Re-creation of a Nineteenth-Century Exterior Paint Scheme</i>
<i>Marc A. Williams</i> <i>Merri M. Ferrell</i> <i>Jennifer Baker</i>	345	Technology and Conservation of Decorative Surface Systems of Horse-Drawn Vehicles
<i>Merri M. Ferrell</i>	363	The Importance of Conservation to Research: A Case Study
<i>Stephen L. Ray</i> <i>Julie A. Reilly</i>	373	The Treatment of Painted Wooden Folk Art
<i>Rick H. Parker</i> <i>Peter L. Sixbey</i>	383	Jeffrey: Horse of a Different Color

#### PART FIVE

### **Ethical Considerations**

<i>Andrew Todd</i>	400	Painted Memory, Painted Totems
<i>Wendy Hartman Samet</i>	412	The Philosophy of Aesthetic Reintegration: Paintings and Painted Furniture
<i>Valerie Reich Hunt</i>	424	Conservation of Folk Art: Shelburne Museum's Collection and Approach
<i>Lynne Dakin Hastings</i> <i>Deborah Bigelow</i>	437	Collaborations Past and Present: A Classical Success Story
<i>Deborah S. Gordon</i>	454	Applied Aesthetics: Restoring the Original Cornice Decoration at Olana

PART SIX

**Scientific Research**

<i>Marion F. Mecklenberg</i> <i>Charles S. Tumosa</i> <i>David Erhardt</i>	464	Structural Response of Painted Wood Surfaces to Changes in Ambient Relative Humidity
<i>Eric F. Hansen</i> <i>Mitchell Hearn's Bishop</i>	484	Factors Affecting the Re-Treatment of Previously Consolidated Matte Painted Wooden Objects
<i>Stefan Michalski</i> <i>Carole Dignard</i> <i>Lori van Handel</i> <i>David Arnold</i>	498	The Ultrasonic Mister Applications in the Consolidation of Powdery Paint on Wooden Artifacts
<i>Richard C. Wolbers</i> <i>Mary McGinn</i> <i>Deborah Duerbeck</i>	514	Poly(2-Ethyl-2-Oxazoline): A New Conservation Consolidant
	529	Contributors
	537	Illustration Credits

# Foreword

**T**HIS VOLUME is probably one of the most ambitious publications projects undertaken to date by the Getty Conservation Institute and certainly the largest in the GCI's Proceedings series. And it is quite appropriate that it be so because the subject matter requires a comprehensive outlook. The importance of painted wood, its beauty, its many forms, and its complexity in the context of conservation required such an approach, particularly given the rapid advance of our knowledge in this area in the past few years. The book had its origin with the symposium organized by the Wooden Artifacts Group of the American Institute for Conservation of Historic and Artistic Works. This was a landmark event that required a full treatment of its contents.

Under the dedicated, disciplined, and enthusiastic editorship of Valerie Dorge and F. Carey Howlett, the present volume encompasses a wealth of material representing the breadth and depth of contributions to that symposium. From the mechanisms to understand and identify the materials that make up painted wood objects to the various factors affecting objects and surfaces, through the multiple analyses, techniques, and treatments of the diversity of painted wood surfaces, this publication attempts to provide an up-to-date compilation of information that would be welcomed by conservators, scientists, art historians, curators, artists, and all those interested in the fascinating array of painted wooden objects created since the earliest times.

One of the Getty Conservation Institute's goals is to contribute information and knowledge about cultural heritage to all those engaged in the conservation and protection of the cultural heritage. This publication is an example of the Institute's commitment to making that information available in ways that are illustrative, accessible, and relevant to the field.

We are delighted to have joined our effort to those of the AIC to bring this volume to professionals and students alike. The contents of the publication, the fine quality of its illustrations, and its format will hopefully be a significant contribution to the study of painted wood. We welcome your comments and hope that you will find as much joy and fascination in the publication as its designers, authors, and editors brought to its creation.

Miguel Angel Corzo  
DIRECTOR  
The Getty Conservation Institute



## Preface

THE UNION OF WOOD AND PAINT is as old as the human desire to protect an object, or simply to decorate a surface,” notes Bruce Hoadley in this volume. Indeed, throughout history, artists and artisans have combined a myriad of pigments, binders, and woods in countless forms. Whether made from common, locally found materials or from exotic commodities obtained through elaborate trade networks, such creations may reflect the inventive fancy of an individual or the formulaic conventions of a rigidly structured tradition. The function of the painted wooden object ranges from the practical to the profound: it performs utilitarian tasks, it conveys artistic whimsy, it connotes noble aspirations, and it embodies the highest spiritual expressions.

Whatever their composition, design, or purpose, however, all painted wooden surfaces share a common problem—they all endure the erosive effects of time, that continuum described by the Roman poet Ovid as a ceaseless “devourer of things.” Use, exposure, response to physical change, chemical interactions, neglect, and a host of other damaging factors act as time’s relentless agents. The condition of a painted wooden object, then, is the telltale gauge of its endurance, a gauge adjusted only by attempts to halt, slow down, or disguise the inevitable effects of time.

The past ten years have seen a wealth of innovative scholarship on the subject of painted wooden objects. Three distinct but interrelated perspectives contribute to this scholarship: the methods of inquiry of the curator or historian, the analytical techniques of the scientist, and the research and treatment practices of the conservator. Much of the best current scholarship incorporates all three of these perspectives with enlightening results. At times, this interdisciplinary approach confirms long-held assumptions about painted wooden objects. In other cases, it forces us to reinterpret their origins, meanings, materials, and methods of manufacture. In all cases, a comprehensive approach increases our understanding of these objects, and leads us to ever new avenues of inquiry.

To both document and further encourage this interdisciplinary exchange, the Wooden Artifacts Group of the American Institute for Conservation of Historic and Artistic Works (AIC) and the Foundation of the AIC sponsored a symposium in 1994 entitled *Painted Wood: History and Conservation*. This publication, the edited proceedings of the symposium, presents a sampling of painted wooden objects, addressing their historic significance, composition, deterioration processes, and methods

developed to preserve them. The conference had two main goals: (1) to look at paint and wood as interdependent and interactive materials, and to examine the preservation problems these interactions present; and (2) to look at painted wooden objects within a cultural context, and to explore the interpretive roles of all who are involved in their study and care.

Most of the papers presented at the symposium and appearing in the proceedings were drawn from a pool of more than seventy submitted abstracts. In addition, articles by Hoadley; Erhardt; Newman; and Mecklenberg, Tumosa, and Erhardt were commissioned to “set the stage” with reviews of the physical and chemical nature of paint and wood. A fifth article, by Martin, was commissioned for the publication to address the examination techniques alluded to in many of the chapters, and is an extension of the demonstration he presented at the symposium.

As an indicator of the collaborative nature of current scholarship, a significant number of articles in this volume were prepared jointly by related professionals—curator and conservator, conservator and conservation scientist, among others. See, for example, the article by curator Hastings and conservator Bigelow, which describes a treatment plan informed by interpretation in order to both “preserve the objects and improve their appearance for presentation within the context of a historic house.” In other instances, a single author presents the results of interdisciplinary research, as exemplified by curator Safford’s study, where paint analysis by conservators and scientists provided “tantalizing evidence [of intense color] that had long aroused the author’s interest and curiosity” and resulted in a new understanding of the decorative qualities of Early American painted furniture.

Other articles encompass a diversity of painted wooden surfaces, including a German late-Gothic sculpture by Tilman Riemenschneider (Marincola and Soultanian); Baroque chapel decor in Minas Gerais, Brazil (Souza and Avila); eighteenth-century English painted garden furniture (White); Northwest Coast totem poles (Todd); and a twentieth-century American carousel figure (Parker and Sixbey). Despite differences in subject matter, most authors address universal concerns in the study and treatment of painted wood. These include questions of authenticity, problems of interpretation, ethical dilemmas confronted during treatment, and technical challenges to the conservation of deteriorating painted surfaces. Interesting contrasts arise because of differing approaches for various object types. Compare for example, the selective inpainting of losses to the polychromy of fifteenth-century Belgian altarpieces (Serck-Dewaide) versus preservation of the weathered surface of a nineteenth-century American trade sign (Hunt). In the same vein, juxtapose the careful stabilization of early decoration on European japanned cabinets (Webb) with the large-scale replication of original paint colors on nineteenth-century American houses (Gilmore; Gordon).

Because of the now prominent role of scientific analysis in the examination and treatment of works of art, one might assume that a thorough investigation is essential to the success of any undertaking. Yet real-world concerns—financial constraints, access to a laboratory, the intrusion of sampling—often preclude extensive scientific analysis. Fortunately, the resourceful investigative methods of the curator and conservator may make extensive analysis unnecessary. This perhaps is best illustrated by contrasting two approaches to the study and treatment of ecclesiastical

architecture in this volume. Because of budget constraints, Hulbert's research and subsequent treatment of alterations to the painted ceiling of Saint Helen's Church in Abingdon, England, were carried out with minimal scientific consultation. Payer and coworkers, on the other hand, report on a large-scale project supported by two major Canadian conservation facilities to investigate alterations, analyze early coatings and remove overpaint from sections of the interior of the Ursuline Chapel in Quebec City. Both projects were highly successful efforts to understand and preserve the painted wood components of elaborate church interiors, yet they differed significantly in their reliance on scientific analysis.

Beyond their focus on the history and conservation of painted wooden objects, these writings share another common element: the exhilaration of discovery. Several articles address promising innovations in conservation techniques and materials (Michalski et al.; Wolbers, McGinn, and Duerbeck), while a number combine historic research with scientific examination to rediscover historic painting techniques (Ballardie; Gold; Mussey; Portsteffen; Shelton; Thornton). Rediscovery also is a fascinating product of conservation examination and treatment: aged layers of overpaint and darkened varnish often cover intricate original decorative schemes (Parker and Sixbey; Williams, Ferrell, and Baker), and their removal sometimes leads to unexpected revelations, as in Ferrell's study of the painted omnibus, the Grace Darling, where conservation "returned the piece to a condition in which its original artistry could be visible and appreciated and . . . led to the discovery of the artist responsible for its extensive ornamentation."

Ultimately the discoveries presented here—the collaborative work of the scientist, curator, art or architectural historian, and conservator—add new layers of meaning to these objects. We hope you will make many exciting discoveries of your own within these pages, and that *Painted Wood: History and Conservation* will give new insight into the complexity, the beauty, the meaning, and the preservation of painted wooden objects.

---

## Editors' Acknowledgments

A symposium and subsequent proceedings of this magnitude are the result of the long-term commitment of a small group of dedicated people, along with the support of many colleagues and many institutions. Though the list is long, the editors wish to acknowledge the contribution of each person and each institution to this project, and apologies are extended to anyone who may have been missed.

In 1992, the Wooden Artifacts Group of the American Institute for Conservation began discussing plans for a symposium on the subject of painted wood. Early the following year, a symposium planning committee was formed, consisting of F. Carey Howlett, the Colonial Williamsburg Foundation, as symposium director; Valerie Dorge, the Getty Conservation Institute, as program chair; with David Bayne, New York Bureau of Historic Sites, Peebles Island; Elisabeth Cornu, Fine Arts Museums of San Francisco; Gregory J. Landrey, the Winterthur Museum; Steven Pine, Fine Arts Museum of Houston; Michael Podmaniczky, the Winterthur Museum; Sarah Z. Rosenberg, executive director of the American Institute for Conservation; and Christine Thomson, then of the Society for the Preservation of New England Antiquities Conservation Center.

This core group was assisted by a symposium advisory board whose members contributed their specific expertise toward the development

of the program and the presentation of the conference. Members of the board were Ian C. Bristow, architect and historic buildings consultant, London; Wendy A. Cooper, then curator, Decorative Arts Department, Baltimore Museum of Art; Pamela Hatchfield, head conservator, Department of Objects, Museum of Fine Arts, Boston; Richard Newman, research scientist, Museum of Fine Arts, Boston; Jack Soultanian, conservator, The Metropolitan Museum of Art and The Cloisters, New York; and Richard Wolbers, associate professor of paintings conservation, Winterthur/University of Delaware Program in Art Conservation, Winterthur.

Following the symposium, the publications committee—Dorge, Howlett, Bristow, Cooper, Cornu, Newman, Soultanian, and Thomson—began the process of guiding the forty symposium papers through to publication.

The editors are grateful to the many people who provided invaluable comments in the manuscript review process. They are William Adair, David Arnold, Mark Aronson, Agnes Gräfin Ballestrem, David Barquist, David Bayne, Geoffrey Beard, Judy Bischoff, Sharon Blank, Susan Buck, Bodo Buczynski, Doris Couture-Rigert, Rene de la Rie, Jane Down, Robert Feller, Nancy Goynne Evans, Frances Halahan, Martha Hamilton, Pamela Hatchfield, Ronald Hurst, Gervase Jackson-Stoppa, Paul Jett, Aldona Jonaitis, Patricia E. Kane, Manfred Koller, Gregory J. Landrey, Carl Lounsbury, Lee Miller, Mark Minor, Matthew Mosca, Cynthia Moyer, L. Cleo Mullins, Claire Munzenrider, Robert Mussey, Scott Odell, Steven Pine, Michael Podmaniczky, Bettina Rapael, Richard Renshaw-Beauchamp, William Robbins, Wendy Samet, Emily Sano, F. Christopher Tahk, Valentine Talland, Peter Volk, John Watson, Marianne Webb, Carolyn Weekley, Frank Welsh, James E. Wermuth, Paul Whitmore, and Richard Wolbers.

The following people contributed to the symposium poster session, and the editors regret that due to the size limitations, their presentations could not be included in this publication: William Adair, Keith Bakker, Jan Braenne, Ina Brousseau Marx, Claudina Maria Dutra Moresi, Richard Ford, William Gauthier, Helen Hughes, Mark Kutney and Philippe Lafargue, Caroline Marchand, James Martin, Alejandro Reyes-Vizzuett and Krassimir Gatev, Henning Schulze, Robert Snowden, and Valentine Talland. Demonstrations during the symposium were presented by Margaret Ballardie, Ina Brousseau Marx, James Martin, and Carole Dignard and David Arnold.

Other people and institutions making important contributions to either the symposium or the publication process include Margaret Whitchurch, Patricia Bare, Bonnie Baskin, Pamela Gladding, Rose Kerr, John Larson, Virginia Lascara, Carol Noel-Hume, Albert Skutans, Lynne Spencer, Christopher Swan, Thomas Taylor Jr., The Agcroft Association, Golden Artist Colors, members of the Virginia Conservation Association, and colleagues at the Colonial Williamsburg Foundation and the Getty Conservation Institute.

The editors are grateful for the encouragement and support of AIC President Deborah Hess Norris, the AIC Board of Directors, all of the staff of the AIC office, and the editors' colleagues in the Wooden Artifacts Group of the AIC, particularly Deborah Bigelow who generously shared her experiences as project director for the previous conference, the Gilded

Wood Symposium, and its proceedings publication, *Gilded Wood: Conservation and History* (1991).

The volume editors of this proceedings publication have benefited from, and appreciated, the contributions and support of all the people listed here. They have also appreciated the dedication of the authors for contributing to a very successful Painted Wood Symposium. Although these proceedings are the culmination of innumerable hours of volunteer effort, a great deal of time and resources were provided by the editors' respective institutions, and they would like to express particular thanks to Director Miguel Angel Corzo and Marta de la Torre of the Getty Conservation Institute; and Robert C. Wilburn, Graham S. Hood and John O. Sands at the Colonial Williamsburg Foundation, for bearing with them for the long haul. Special thanks are extended to Dinah Berland, who managed the editorial production at the GCI with the valuable assistance of consultants Nomi Kleinmuntz, who copyedited the texts; and Scott Patrick Wagner, who provided a range of editorial services in preparing the manuscript for publication. Thanks also to the staff of the GCI Information Center, especially Valerie Greathouse for her helpful research.

Finally, on behalf of the symposium committee and advisory board colleagues, the editors extend a debt of gratitude to the Colonial Williamsburg Foundation for helping to make the Painted Wood Symposium a reality, and to the Polly M. Stone 1992 Trust for a generous contribution toward the cost of printing color illustrations throughout this book.

Valerie Dorge and F. Carey Howlett

PART ONE

# Understanding and Identifying Materials

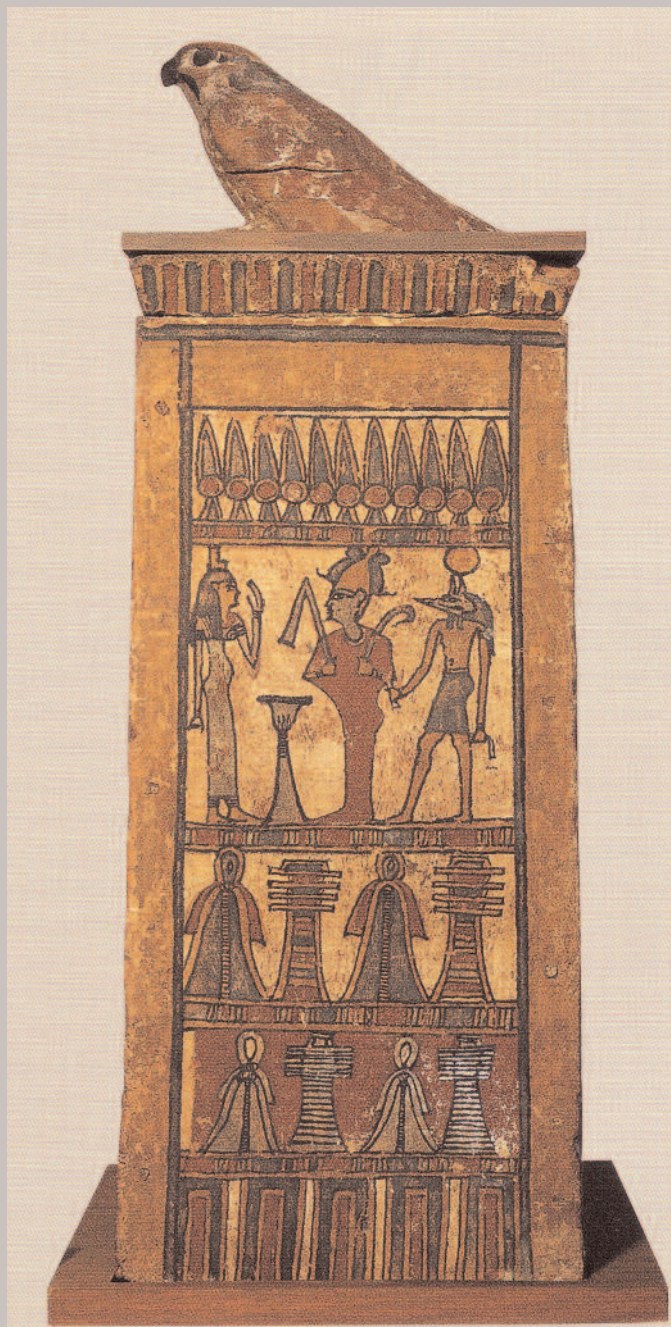

# Wood as a Physical Surface for Paint Application

R. Bruce Hoadley

WOOD HAS ALWAYS BEEN a vital factor in human existence and has provided an array of blessings, from basic needs to fanciful luxuries. It is not surprising that as we survey our heritage, we find deep involvement with artifacts of wood, both utilitarian and decorative. In the study of decorative arts, attention is easily focused on design and aesthetics, as is so often the case with painted wood, while the wood itself may well receive the least consideration.

To explore wood is to realize its complexity, its diversity, and its variability. That a material with such a simple designation as *wood* could in fact be so complicated is part of its fascination. On the one hand, wood is a straightforward and simple material, a delightful bounty of nature, to be used at will. On the other hand, wood has its ability to remain enigmatic and troublesome. The union of wood and paint is as old as the human desire to protect an object, or simply to decorate a surface. The link between paint and wood is therefore at the heart of any approach to conservation of these objects. To the conservator, the analysis of conditions and problems involves a familiarity with the physical structure of the wood as a material and with its surface interaction with the applied paint, as well as with the behavior of the wood after paint application.

Evaluating a wood surface begins by exploring the wood itself, with the realization that every surface is different from the next and cannot be predicted in detail. This article will therefore focus on the basic anatomical structure of wood tissue to provide an understanding of potential surfaces generated by cutting through it. In addition, pertinent physical properties will be summarized, with particular attention given to the wood's response to variation in atmospheric humidity and resulting dimensional changes.

---

## The Universe of Wood

Wood is the tissue of stems and branches of higher order plants—trees—within the division of the plant kingdom known as the spermatophytes, which includes all seed plants. Within the spermatophytes are two classes, the gymnosperms and the angiosperms. Taxonomically, these classes are further arranged into orders, families, genera, and finally species. Throughout the world there are well over one hundred thousand species of woody plants, but fewer than one percent are utilized in any significant quantity.

Among the vast array of tree species, the most familiar and most used woods are obtained from trees that we know as hardwoods and softwoods. The angiosperms are grouped into two subclasses, the monocotyledons (which includes palms, rattans, bamboo, etc.) and the dicotyledons, the source of the woods we know as *hardwoods*. The woods we call *softwoods* are from trees of the gymnosperms, principally in the order Coniferales; thus these trees are also known as *conifers*. The traditional terms hardwood and softwood have no accurate reference to the relative hardness and softness of the wood, and should therefore be interpreted simply as designations for the two major botanical groups they represent. Although tree stems of both hardwoods and softwoods have many similar characteristics of form and gross features, there are categorical differences of anatomical detail between the two groups of woods.

---

## The Tree Stem and Its Wood

The tree has a main supporting stem or trunk, the portion most commonly used for lumber and veneer. When a cylindrical log is removed from the stem by crosscutting, the exposed ends of the log reveal the outer layer of bark. Interior to the bark, and comprising the bulk of the stem, is the wood, characterized by its many growth rings arranged concentrically around the central pith. Between the bark and the wood is a microscopically thin layer of living tissue, the cambium, whose cells divide during the growing season to produce new wood cells to the inside, bark to the outside.

### Wood cells and tissues

The cell is the basic structural unit of plant material, and, accordingly, wood tissue is a physical structure of countless cells. Wood cells are typically elongated, although the proportions of length to diameter vary widely among cell types, from short barrel shapes to long needle-like cells.

Wood tissue consists mainly of elongated cells whose long axes are oriented vertically in the tree and are referred to as *longitudinal cells*. These cells are mostly too small in diameter to be seen without magnification, but in a few species, such as ash (*Fraxinus* spp.), chestnut (*Castanea* spp.), and mahogany (*Swietenia* spp.), the largest can be seen with the unaided eye. The direction of these dominant longitudinal cells gives wood its *grain* direction, parallel to the stem axis.

Scattered through the wood are cells called *ray cells*, whose axes are perpendicular to the longitudinal cells. These cells occur in flattened, ribbonlike groups called rays; the *ribbons* lie horizontally in the tree (the plane of the ribbon vertical), extending inward from the cambium toward the pith. Individual ray cells and even smaller rays are too small to see, but rays vary in size according to the number of cells contained within them, and in some species, such as oak (*Quercus* spp.) and beech (*Fagus* spp.), the largest rays are easily seen on wood surfaces.

Each wood cell consists of an outer cell wall surrounding an inner cell cavity. The cell wall is about 70% cellulose and hemicellulose, the remainder mostly lignin, and typically 1–5% extractives (as will be discussed), mineral traces, et cetera. The cellulose is oriented within the layered cell wall in a manner to give the greatest strength and dimensional stability parallel to the cell axis (Fig. 1).



Figure 1

Diagrammatic representation of a typical longitudinal wood cell, such as a coniferous tracheid or a hardwood fiber, showing the layering of the cell wall and the organization of cellulosic molecular structure into fibrils with crystalline and amorphous arrangement.

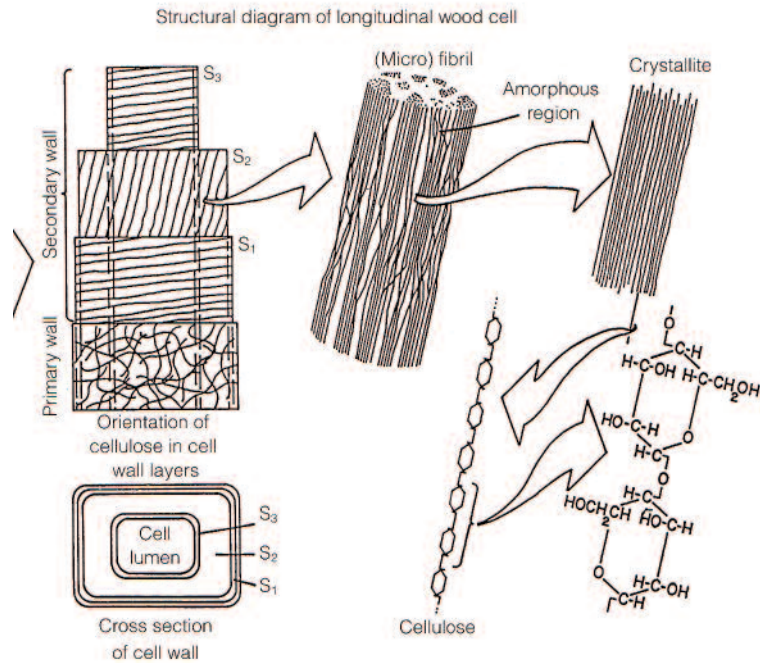

In considering wood as an interface for paint, it is important to recognize that a wood surface is the aggregate of severed or fractured wood cells whose physical configuration depends on the dimensions and orientation of the cells involved and whose surface chemistry reflects the chemical structure of the cell wall and the cell contents, as well as exposure to environmental pollutants.

### Sapwood and heartwood

In the living tree, as new wood cells are being added to the latest growth ring by division of the cambial cells, the living protoplast disappears from the cavities of most wood cells as they become specialized for conduction or support of the tree. A few cells retain a living protoplast and continue as living cells, with the capability of metabolizing and storing food for the tree. The most recently formed rings of growth to the inside of the cambium and bark are called *sapwood*, which has the capability of transporting sap and storing food. The sapwood, the cambium, and the last-formed inner bark constitute the living portion of the tree. As a tree stem increases in diameter, the entire stem is not used to supply the crown with sap. The central wood of the stem ceases to function in vital activity and transforms to *heartwood*. This conversion to heartwood is usually accompanied by the deposition of materials called *extractives* on and within the cell walls. Extractives may alter properties and behavior of the wood. For example, it is the pigmentation of extractives that gives the heartwood any characteristic color it may have.

### Growth rings

One recognizes wood by its growth rings, which are revealed in recognizable patterns on exposed wood surfaces. In temperate regions of the world, the growth cycles are yearly and produce annual rings. The distinctiveness of the growth ring is a species characteristic determined by cell

structure, usually by the variation of cell diameter or by the distribution of different types of cells. Where there is visual contrast within a single growth ring, the portion formed in the spring is called *earlywood*, the remainder *latewood*. In species such as larch (*Larix* spp.) or oak, the contrast between earlywood and latewood is conspicuous, and the wood is said to be *uneven-grained*. In other species, such as sweetgum (*Liquidambar styraciflua*) or holly (*Ilex* spp.), there may be little variation within each growth ring, perhaps requiring magnification with lens or microscope to discern the individual growth rings. In such cases, earlywood and latewood cannot be designated, and the wood is said to be *even-grained*.

## Structural Arrangement within the Tree Stem

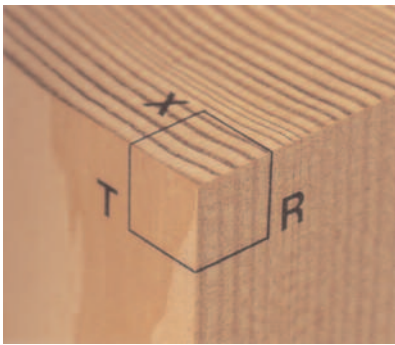

Figure 2

A block of Douglas-fir sawn to show the characteristic appearance of transverse, or cross-sectional (X), radial (R), and tangential (T) surfaces.

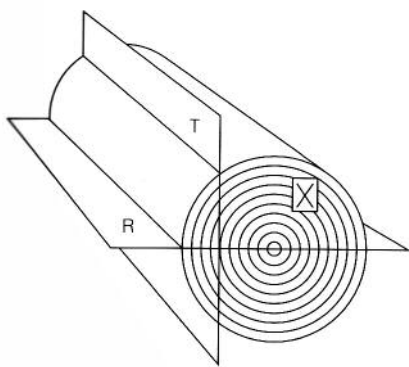

Figure 3

The fundamental structural planes of wood, as indicated in Figure 2.

In view of the concentric arrangement of growth rings around the central axis of the tree, as well as the orientations of longitudinal and ray cells, it is appropriate to consider wood tissue as a three-dimensional structure. The organization of the wood tissue thereby provides a basis for designating coordinate directions and structural planes within the wood. The three fundamental planes of wood are the transverse (cross-sectional), radial, and tangential planes. These terms equally apply to the surfaces that are exposed by cutting the wood in the respective planes, or to thin sections removed for microscopic study. The letters X, R, and T are commonly used to designate transverse, radial, and tangential planes, respectively, as well as corresponding surfaces or sections (Fig. 2).

Viewing a tree stem (or log) as a cylinder, any plane perpendicular to its length is a *transverse plane*, or *cross-sectional plane*, typically observed as the end of a log or board (X in Fig. 3). A plane that bisects the cylinder lengthwise through the center of the log, or the pith, is called a *radial plane* (R in Fig. 3). Any lengthwise plane that does not pass through the pith forms a tangent to its growth-ring structure and is called a *tangential plane* (T in Fig. 3). Because of growth-ring curvature, this plane is most accurately tangential where it intersects and is perpendicular to a radial plane. In preparing a small cube of wood for study, however, the curvature of the rings is usually insignificant, so the cube can be oriented to contain quite accurate transverse, radial, and tangential surfaces.

In wood harvested for use, the surfaces of boards or other components are usually cut parallel to the log axis and therefore are crosscut to transverse surfaces at the end. Their *side-grain* surfaces may not be specifically radial or tangential but intermediate to the two, or even a combination of both. Any board or outer slabbed face of a log is loosely accepted as a tangential board or surface.

Terminology applied to lumber and veneer is derived in some cases from the structural orientation within the log and, in some cases, from the manner of sawing the material. Tangentially cut boards and veneer—and their surfaces—are termed *plain-grained*, *flatsawn* or *flat-grained*, or *slash-grained*. Radially cut pieces are said to be *vertically grained*, *edge-grained*, or *quartersawn*.

## Softwoods and Hardwoods

The tree-stem and cellular characteristics of wood discussed here are applicable without regard to specific type, but further investigation of the nature and properties of woods is best done in recognition of some of the distinct differences between the softwoods and hardwoods.

### Specific gravity

Relative density, or specific gravity, is an important physical property of wood. It is related to strength and dimensional behavior and it affects paint application, as well. In comparing softwoods and hardwoods, it is valuable to consider the ranges of specific gravity represented by the two groups. Wood density is expressed as oven-dry weight per unit volume. Specific gravity of a given wood is determined by comparing the density of the wood to the density of water, which is  $1 \text{ g cm}^{-3}$ . For example, a wood weighing  $500 \text{ kg m}^{-3}$  would have a specific gravity of 0.5.

Figure 4 shows a number of representative woods listed opposite their respective average values of specific gravity. Note that the range of softwoods is approximately from 0.3 to 0.65, the heaviest little more than twice the density of the lightest. Among hardwoods, however, the range is from 0.15 to 1.3. It is evident that the traditional terms softwood and

Figure 4  
The specific gravity of selected softwoods and hardwoods.

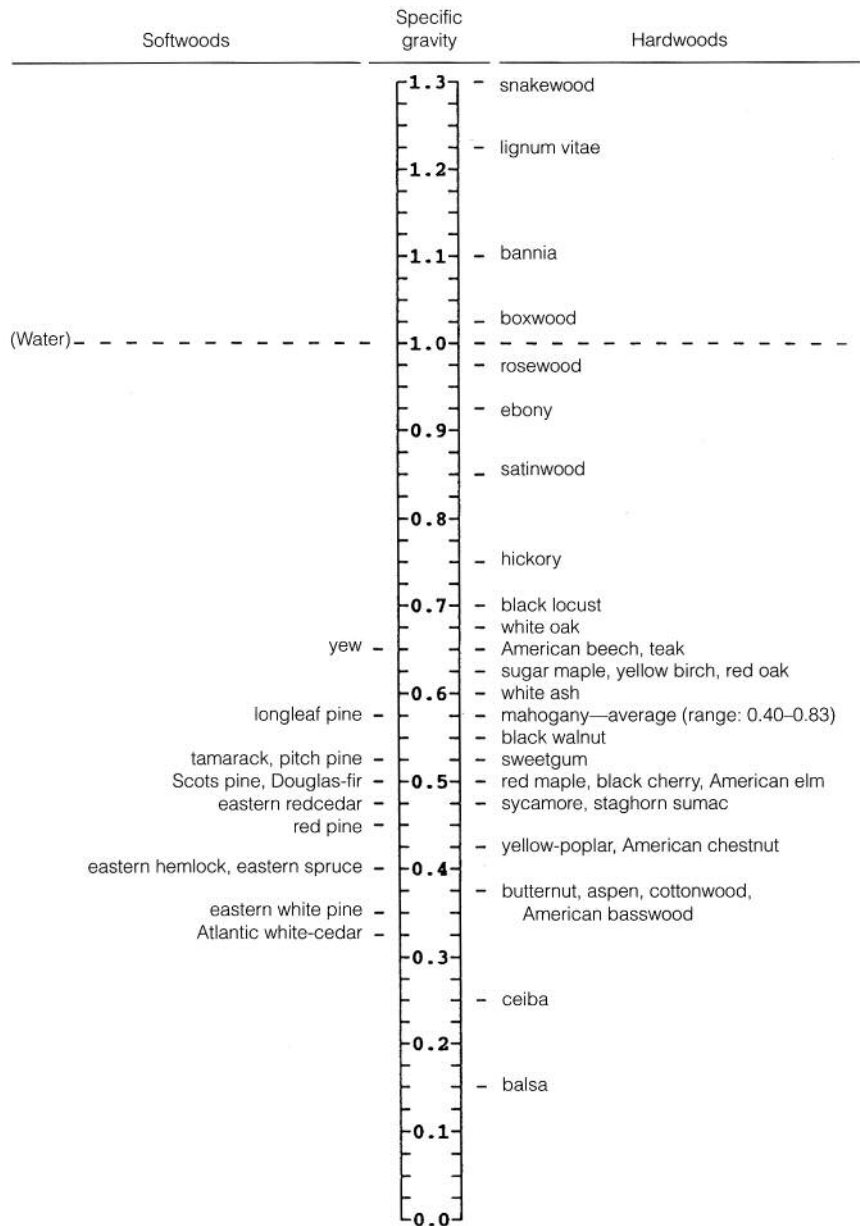

hardwood have no literal accuracy and should therefore be interpreted as designations for botanical groups rather than density groups.

The complex of cellulose and lignin forming the walls of wood cells has a specific gravity of approximately 1.5. The average specific gravity should therefore suggest something of the nature of cell types to be found in a wood. For example, in a wood such as lignum vitae (*Guaiacum* spp.) with a specific gravity of about 1.2, one might expect to find cells with very thick walls and relatively small cell cavities. A wood as light as balsa (*Ochroma pyramidale*) will have relatively thin walls and large cell cavities.

## Cell structure

The most obvious differences between hardwoods and softwoods are apparent when the cell structure of the two groups is compared. Within either group, analysis of cell structure accounts for the extent of earlywood-latewood variation within a single growth ring. Figure 5a–d shows examples of the cell structure of representative softwoods and hardwoods.

### Softwood cell structure

Among the softwoods, the bulk of the wood tissue (approximately 90% by volume) consists of longitudinal tracheids. These cells are conspicuously elongated, with lengths of up to one hundred times their diameters, the lengths averaging from 2 to 7 mm among the various conifers. Transverse sections (Fig. 5a–d, left-hand column) reveal that the tracheids occur in rather uniform radial rows, and that they are quite uniform in tangential diameter. Among the conifers, the diameters of the tracheids are used as a relative measure of the texture of the woods. Tracheid diameters range from an average of 60–70  $\mu\text{m}$  in the coarsest textured softwoods, such as baldcypress (*Taxodium distichum*) and redwood (*Sequoia sempervirens*), to an average of only 15–20  $\mu\text{m}$  in fine-textured softwoods, such as yew (*Taxus* spp.) and eastern redcedar (*Juniperus virginiana*). Many softwoods, such as eastern white pine (*Pinus strobus*) and spruce (*Picea* spp.), have average tracheid diameters in the medium texture range of 30–40  $\mu\text{m}$ . It is apparent that the average diameter and cell-wall thickness of the earlywood tracheids will determine the physical surface configuration on machined wood surfaces and will thereby be related to the ability of a surface coating to fill or penetrate the wood surface.

Tracheids are largest in radial diameter in the earlywood. Radial diameter decreases and cell walls become thicker toward the latewood portion of the growth rings, resulting in greater density and darker appearance of the latewood. The extent of variation of radial diameter and cell-wall thickness determines the overall contrast in density between earlywood and latewood. The lower density softwoods, such as eastern white pine and northern white cedar (*Thuja occidentalis*), have minimal change of density from earlywood to latewood. These woods tend to have fairly uniform working properties, as well. The higher density softwoods, such as larch, Douglas-fir (*Pseudotsuga menziesii*), or southern yellow pine (*Pinus* spp., southern group), have thin-walled earlywood but strikingly thicker latewood. The southern yellow pines, for example, typically average 0.5–0.6 specific gravity overall. However, these values represent the average of earlywood of 0.3 specific gravity and latewood of up to 0.95 specific gravity. This variation renders drastic differences in radial and tangential surfaces and the tissue exposed, and to paint applied to them.

Figure 5a-d

Transverse surfaces (left-hand column) ( $\times 4.08$ ) and stained sections (right-hand column) ( $\times 40.8$ ) of representative softwoods and hardwoods: (a-1, a-2) longleaf pine (*Pinus palustris*), an uneven-grained softwood; (b-1, b-2) eastern white pine (*Pinus strobus*), an even-grained softwood; (c-1, c-2) northern red oak (*Quercus rubra*), a ring-porous hardwood; and (d-1, d-2) American basswood (*Tilia americana*), a diffuse-porous hardwood.

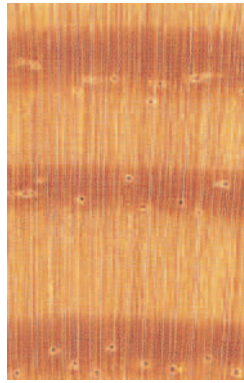

a-1

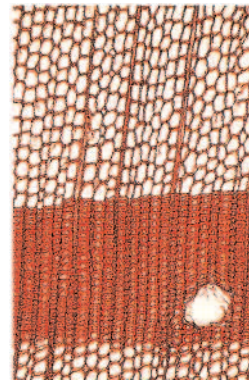

a-2



b-1

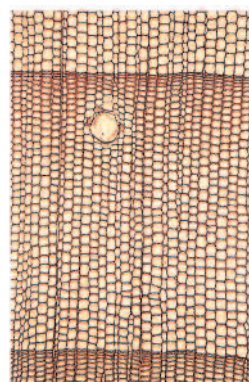

b-2

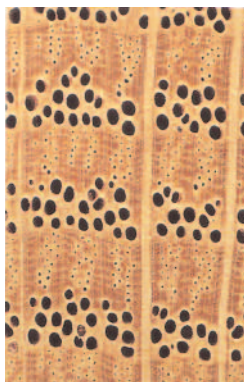

c-1



c-2

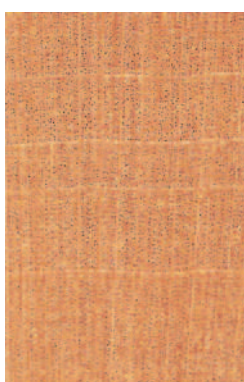

d-1

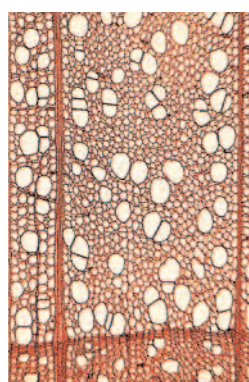

d-2

Certain softwoods—such as pines (*Pinus*), spruces, larches, and Douglas-fir—have *resin canals* (tubular passageways that occur randomly through the wood) both longitudinally and radially. Epithelial cells line the resin canals and exude resin, or “pitch,” into them. The contents of the resin canals may emerge on wood surfaces, interfering with the bonding of paint films or bleeding through painted surfaces.

Some of the conifers, such as cedars, redwood, and baldcypress, have a cell type known as *longitudinal parenchyma*. These are short cells that occur in vertical strands, a given strand occupying the analogous position of a single longitudinal tracheid. Although few in number, these cells commonly have colored contents in their cell cavities. The materials of these inclusions may bleed through to the surfaces of paint layers and cause resulting discoloration of painted surfaces.

Softwoods have relatively small rays, usually only one cell wide (as viewed tangentially). The rays have an insignificant effect on wood surfaces relative to paint films.

### Hardwood cell structure

Compared to softwoods, hardwoods exhibit several major differences in cell structure. First, hardwoods have many more specialized types of longitudinal cells, representing a wider range of dimensions and relative cell-wall thickness. Because of the variety of cell sizes, arrangement of cells is typically irregular, compared to the orderly radial rows of tracheids that characterize softwood structure. Second, where earlywood-latewood variation occurs, it results from the sorting of different cell types across the growth ring. Third, ray size among hardwood species varies from invisibly small rays (as routinely found in the softwoods) to very large, visually conspicuous rays.

Longitudinal cell types in hardwoods are specialized according to function and vary from the large diameter and thin-walled *vessel cells*, specialized for conduction, to the smallest diameter and sometimes very thick-walled *fiber cells*, obviously specialized to contribute strength to the tree. There are intermediate cell types, as well.

The most conspicuous cell types in hardwoods are the vessel cells. These cells, also referred to as *vessel elements*, form in the tree in an end-to-end arrangement; because they no longer have end walls, these cells form continuous conductive pipelines. In comparing hardwood species, the average diameter of the largest vessels serves as a relative measure of texture. The coarsest textured woods—such as oak, chestnut, ash, and mahogany—have vessel diameters of up to 300–350+  $\mu\text{m}$ . Vessels of this size are easily seen with the unaided eye on cleanly cut surfaces. At the other extreme, vessel diameters average only 40–60  $\mu\text{m}$  in holly and 50–80  $\mu\text{m}$  in sweetgum. The vessel elements in such fine-textured hardwood are invisibly small and can scarcely be discerned with a 10 $\times$  hand lens. In medium-textured woods, such as birch or cottonwood, the larger vessels average 130–150  $\mu\text{m}$  in diameter and are barely visible.

When vessels are cut transversely, the exposed open ends on a cross-sectional surface are referred to as *pores*. Evenness of grain in hardwoods is largely determined by the distribution of vessels and fibers and can be assessed by noting the arrangement of pores on a transverse surface. If the largest pores are concentrated in the earlywood, the wood is said to be *ring-porous*. In a typical ring-porous wood (Fig. 5c-1, c-2), it is

the zone of large pores that defines the earlywood portion of the growth ring. Latewood pores are much smaller. Oak and ash are examples of ring-porous woods. In these woods, the thin-walled earlywood vessels are surrounded by other cell types—parenchyma cells and tracheids, which are much smaller in diameter and also thin walled. Collectively, therefore, the earlywood is a weaker, softer layer than the latewood—which is dominated by fibers of small diameter and very thick walls, resulting in relatively dense tissue. Most ring-porous woods are, therefore, inherently uneven-grained. In the highest density ring-porous woods, such as black locust (*Robinia pseudoacacia*) or hickory (*Carya* spp.), the earlywood zone of large pores is narrow, and the latewood is characterized by fewer, smaller pores and fibers with extremely thick walls. In lower density ring-porous woods, such as chestnut and catalpa (*Catalpa* spp.), the latewood is characterized by greater numbers of latewood pores or masses of thinner walled fibers.

If the pores are uniform in size, and evenly distributed throughout the growth ring, the wood is said to be *diffuse-porous* (Fig. 5d-1, d-2). Woods in this category include maple (*Acer* spp.) and basswood (*Tilia* spp.). Although most diffuse-porous woods of the temperate regions are rather fine textured, many diffuse-porous tropical woods, such as mahogany, are coarse textured. Ring-porous tropical species, such as teak (*Tectona grandis*), are least common. Ideally, diffuse-porous woods such as maple and sweetgum are so even-grained that there may be little or no indication of earlywood and latewood; the growth-ring boundary may be delineated only by a slightly darker coloration in the most recently formed fibers.

Some woods, such as butternut (*Juglans cinerea*) and black walnut (*Juglans nigra*), are *semi-ring-porous*. Large pores are found at the earlywood edge of the growth ring, but pore diameter decreases gradually across the growth ring to a small diameter in the outer latewood, with no apparent delineation of earlywood and latewood. Some woods, such as cottonwood (*Populus* spp.) and willow (*Salix* spp.), have medium to medium-small pores that gradually diminish in diameter to smaller and fewer pores in the latewood. These woods are called *semi-diffuse*.

The size of rays varies widely among hardwood species. In only a few hardwoods, such as chestnut, aspen (*Populus* spp.), and willow, the rays are exclusively uniseriate (that is, only one cell in width as viewed tangentially), as is found in most softwoods. In many hardwoods—such as ash, basswood, and birch (*Betula* spp.)—the rays range from two to several cells in width (multiseriate) but are still inconspicuous. In some woods—such as maple, cherry (*Prunus* spp.), or yellow-poplar (*Liriodendron tulipifera*)—the multiseriate rays may be imperceptible on tangential surfaces but may display a conspicuous pattern, known as *ray fleck*, on a radial surface. In beech and sycamore (*Platanus occidentalis*), the multiseriate rays are easily seen on tangential surfaces and appear as pronounced ray fleck on radial surfaces. Oaks have rays of two distinct sizes; most are uniseriate and invisibly small, but some are very large. These multiseriate rays are up to thirty to forty seriate, and measure up to an inch in height in the red oaks (*Quercus* spp., subgenus *Erythrobalanus*) and up to several inches in height among the white oaks (*Quercus* spp., subgenus *Leucobalanus*). Radial surfaces of oak may display a dominant ray fleck figure, with large patches of ray tissue exposed.

---

## Wood-Moisture Relationships

No discussion of wood properties and performance can be complete without consideration of moisture and its relationship to dimensional change. It is customary to think of the moisture content of wood as that which can be driven off by heating the wood to 100–105 °C. Moisture content of wood is measured quantitatively as the ratio of water weight in a sample of wood to the oven-dry weight of the wood, expressed as a percentage. For example, if a stick of wood originally weighed 112 g but weighed only 100 g after oven drying, the 12 g weight loss divided by the oven-dry weight of 100 g would indicate a moisture content of 0.12, or 12%.

Trees contain a liquid referred to as sap, which is mostly water with dissolved trace minerals and nutrients. In considering the properties and behavior of wood, it is appropriate to think of the moisture in wood simply as water, whether it is the original sap leaving the wood or other water reentering the wood.

Water exists in two forms in wood tissue—as bound water and as free water. In the “green” wood of living trees, the cell walls are saturated and fully swollen with molecular water held by chemical attraction within the fibrillar structure. This water is called *bound water*. The moisture content at which all cells are saturated with bound water is the fiber saturation point, which represents a moisture content of about 28–30%.

Water in the tree in excess of the fiber saturation point exists simply as liquid water in the cell cavities and is called *free water*. When wood is dried, the free water is the first moisture to be lost from wood tissue. Only when all free water has evaporated and diffused out of the wood tissue will the bound water begin to leave, thus affecting the cell walls. Loss of free water has little effect on wood properties other than weight, but as bound water leaves the cell walls, the wood increases in strength and shrinks in dimension.

## Hygroscopicity

When wood is initially dried or “seasoned” for use, all of the free water is removed, plus some of the bound water. The amount of water remaining is determined by the relative humidity of the surrounding atmosphere. Because the humidity usually varies, the bound water content of wood varies also, losing or desorbing moisture when the humidity is low, gaining or adsorbing moisture when the surrounding air is humid. The term *equilibrium moisture content* indicates the level of bound water moisture content that a piece of wood will eventually attain when exposed to a given level of relative humidity. The relationship between relative humidity and equilibrium moisture content is shown in Figure 6 for a typical species, white spruce (*Picea glauca*). An important factor not indicated in this illustration is time; obviously, thicker pieces of wood will take longer periods of time to reach a new equilibrium in a new environment. The cell walls at the surface will respond almost instantaneously; thin veneers may take only a matter of hours; and thick planks may take weeks or months to reach equilibrium, depending on other factors, such as density.

## Dimensional response

Dimensional change is perhaps the most telling consequence of bound water sorption. As bound water is adsorbed into the cell walls, the fibrils



Figure 6  
Relationship between equilibrium moisture content and relative humidity for white spruce, subject to normally variable atmospheric conditions.

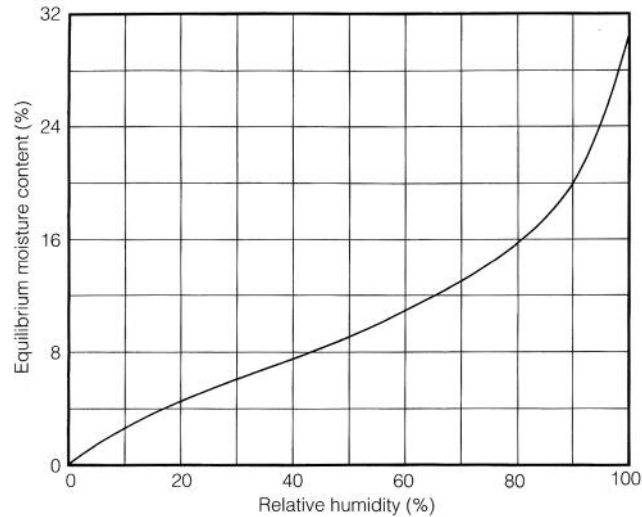

expand laterally, and collectively the wood cells swell, principally across the grain. Conversely, as wood loses moisture, the wood shrinks.

Shrinkage and swelling of wood is approximately proportional to moisture content change over the range of moisture content between the fiber saturation point and the oven-dry condition. However, dimensional change is dramatically different according to the anatomical direction in the wood, and varies among species, so shrinkage is determined separately in the tangential, radial, and longitudinal directions for each species. It is common to express dimensional change in wood as a total shrinkage percentage, which is determined by measuring a fully swollen piece before and after drying and dividing the loss of dimension by the original dimension. For example, if a flatsawn board measured 25.40 cm across its tangential width when green but only 23.36 cm when oven-dried, the loss of 2.04 cm divided by the original 25.40 cm would indicate a shrinkage of 8%.

Longitudinal shrinkage for normal wood of all species averages only 0.1–0.2%. Fractional amounts due to humidity-induced moisture content changes are insignificantly small and are usually ignored. It is usually assumed that wood is dimensionally stable in the grain direction; transverse dimensional change is both significant and troublesome; tangential shrinkage among species varies from 4% to 12%, but the average is about 8%; and radial shrinkage is only about half this magnitude, typically about 4%, but ranging from 2% to 8% among various species. Boards or panels cut from the wood with growth-ring placement that is intermediate between flatsawn and quartersawn will understandably have intermediate dimensional properties. Table 1 lists values of tangential and radial shrinkage for a number of representative woods.

The approximate amount of shrinkage or swelling to be expected in a piece of wood can be estimated on the basis of anticipated variation in relative humidity, as illustrated in Figure 7. This diagram can also be used in conjunction with the values in Table 1 for making comparisons between alternatives, such as between species or between radial and tangential cuts of the same species.

Warp in boards or panels is the result of uneven dimensional change, and can take such forms as *cup* (distortion across the width of a board), *bow* (end-to-end distortion along the flat surface of a board), *crook* (end-to-end deformation along the edge of a board), or *twist* (four corners

Table 1 Shrinkage percentages for common woods (Hoadley 1980:74)

Species	Tangential shrinkage (%)	Radial shrinkage (%)
<b>Softwoods</b>		
baldcypress ( <i>Taxodium distichum</i> )	6.2	3.8
Douglas-fir (coastal) ( <i>Pseudotsuga menziesii</i> )	7.8	5.0
fir, balsam ( <i>Abies balsamea</i> )	6.9	2.9
hemlock, eastern ( <i>Tsuga canadensis</i> )	6.8	3.0
pine, eastern white ( <i>Pinus strobus</i> )	6.1	2.1
pine, longleaf ( <i>Pinus palustris</i> )	7.5	5.1
pine, red ( <i>Pinus resinosa</i> )	7.2	3.8
redcedar, eastern ( <i>Juniperus virginiana</i> )	4.7	3.1
redwood (old growth) ( <i>Sequoia sempervirens</i> )	4.4	2.6
spruce, red ( <i>Picea rubens</i> )	7.8	3.8
tamarack ( <i>Larix laricina</i> )	7.4	3.7
white cedar, northern ( <i>Thuja occidentalis</i> )	4.9	2.2
<b>Hardwoods</b>		
ash, white ( <i>Fraxinus americana</i> )	7.8	4.9
aspen, quaking ( <i>Populus tremuloides</i> )	6.7	3.5
basswood, American ( <i>Tilia americana</i> )	9.3	6.6
beech, American ( <i>Fagus grandifolia</i> )	11.9	5.5
birch, yellow ( <i>Betula alleghaniensis</i> )	9.2	7.2
butternut ( <i>Juglans cinerea</i> )	6.4	3.4
cherry, black ( <i>Prunus serotina</i> )	7.1	3.7
chestnut, American ( <i>Castanea dentata</i> )	6.7	3.4
cottonwood, eastern ( <i>Populus deltoides</i> )	9.2	3.9
elm, American ( <i>Ulmus americana</i> )	9.5	4.2
hickory, shagbark ( <i>Carya ovata</i> )	10.5	7.0
mahogany ( <i>Swietenia</i> spp.)	5.1	3.7
maple, sugar ( <i>Acer saccharum</i> )	9.9	4.8
oak, northern red ( <i>Quercus rubra</i> )	8.6	4.0
sweetgum ( <i>Liquidambar styraciflua</i> )	10.2	5.3
sycamore ( <i>Platanus occidentalis</i> )	8.4	5.0
teak ( <i>Tectona grandis</i> )	4.0	2.2
walnut, black ( <i>Juglans nigra</i> )	7.8	5.5
willow, black ( <i>Salix nigra</i> )	8.7	3.3
yellow-poplar ( <i>Liriodendron tulipifera</i> )	8.2	4.6

For each species listed, the average values for total linear shrinkage in the tangential and radial directions are given. Each value is the ratio of total dimensional change (shrinkage) to the original green dimension, expressed as a percentage.

of a board that do not lie in a plane). Cup is perhaps the most familiar and usually is seen in flatsawn boards, due to the difference between radial and tangential shrinkage. In a flatsawn board, the surface layer nearest the pith is more nearly radial than the opposite surface that was nearer to the bark. The pith side will therefore shrink or swell less, the bark side

Figure 7

Chart for the estimation of shrinkage or swelling of wood. For example, longleaf pine (*Pinus palustris*) has a tangential shrinkage percentage of 7.5% (from Table 1). As shown by the dashed lines on the chart, a moisture content change ( $\Delta MC$ ) from 14% to 7% would produce a dimensional change ( $\Delta D$ ) of approximately 1.75% across the face of a flatsawn (tangentially cut) board.

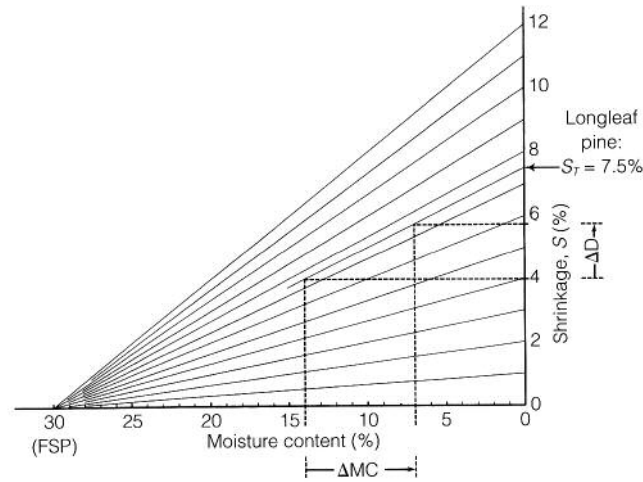

more, and the board will cup—concave to the bark side as it dries or concave to the pith side as it gains moisture.

A noteworthy effect of dimensional behavior is known as *compression shrinkage*. This occurs when a relatively dry piece of wood is restrained from normal perpendicular-to-grain swelling as its moisture content increases. This has the effect of crushing the wood. Wood has the ability of deforming elastically less than 1%, and any additional crushing will cause permanent set. If the now-crushed wood is returned to its original moisture content, it will shrink to a smaller dimension than it had originally. This apparent loss of dimension is compression shrinkage.

Compression shrinkage is well known as the cause of loose tool handles and wobbly furniture. It is also the major cause of surface checking in unprotected board surfaces. When a relatively dry wood surface is exposed to extremely high humidity or is directly wetted, the surface layer of wood cells quickly adsorbs moisture to fiber saturation. The wet surface-wood cells attempt to swell but are held in place by the restraint of the substrate of dry, unswollen wood beneath. The restrained surface layers take on compression set. When eventually redried to the original moisture content, the stress-set surface will shrink excessively (compression shrinkage) and may cause the board to cup or develop surface checks. Each time the cycle is repeated, wetting occurs in the previously opened checks, damaging and deepening each one a little more. This is a primary mechanism in the surface weathering of unprotected wood. It also explains why weathered boards are usually cupped to the weathered side, regardless of the placement of growth rings.

Dimensional change in wood shows significant correlation with specific gravity. With some exceptions, the higher the specific gravity, the greater the shrinkage percentage. It follows that dimensional change is variable in woods with variable density tissue. In southern yellow pine, for example, the latewood will swell and shrink more than earlywood.

---

## Summary

In the overview of anatomical features and properties presented here, the objective is to characterize the physical nature of wood as a potential surface for paint application. This also provides a basis for summarizing some of the specific points of interest relative to interaction with a coating of paint (see also Mecklenberg, Tumosa, and Erhardt, herein). A paint layer

interacts with the wood physically to the extent that it flows into the depressions created by the cell cavities at the surface, and to some extent even deeper, according to its ability to penetrate additional cells through pits and perforations of the cell walls. Paint also interacts chemically, by bonding to chemically reactive sites exposed at the surfaces of any cells contacted. Once the paint layer has set, it must then survive the mechanical stresses of dimensional change in the wood substrate, as well as the chemical degradation of the adhesive bonding with the wood.

The wood and the paint film share an interesting symbiotic relationship. For its survival, the paint film depends on the stability and bonding sites of the wood surface; at the same time, the wood surface relies on the paint film to mitigate the sorption of moisture that changes its dimensional status and competes for bonding sites, and to shield the chemical bonds between wood and paint from the degradation of ultraviolet light.

In reviewing the features of wood relative to the paint layer, the three-dimensional structure of wood is of primary importance, since it results in such a contrast in surfaces depending on the plane of cut. The greatest contrast is between end-grain (that is, transverse or cross-sectional) surfaces and side-grain (that is, tangential, radial, or any intermediate longitudinal) surfaces. The end grain is in many respects more “open” to surface penetration as it is generally found that wood is approximately ten to fifteen times more permeable to liquids in the direction of the longitudinal cells than perpendicular to them. However, the end-grain surface presents reduced exposure of chemical bonding sites and is subject to major dimensional change in every direction. The greater longitudinal permeability of wood exacerbates the consequence of dimensional response near end-grain surfaces. Compression shrinkage and resulting radial checks into the ends of boards are therefore more severe than into side-grain surfaces.

The exposure of cell cavities along side-grain surfaces presents relatively shallow depressions for the paint layer interface, depending on the texture of the species, whereas a maximum of chemical bonding may be available. Along longitudinal surfaces the wood is quite stable in the grain direction, but unstable perpendicular to the grain. Here the importance of growth-ring placement becomes apparent, given that wood is approximately twice as unstable tangentially as radially.

The average specific gravity of wood tissue is related to the integrity of paint films in two important ways. First, lower density generally reflects thinner cell walls and relatively greater cell-cavity volume open to the surface, with resulting greater intervention of the paint film into the wood surface. Second, greater specific gravity not only predicts greater dimensional change across the surface, but also means that the paint layer has less ability to restrain the dimensional change of the surface. Among even-grained woods—that is, woods with uniform distribution of cell size—lower density and coarser textured woods therefore provide an excellent surface for establishing a paint layer with the best chance of survival under varying conditions of moisture. Conversely, dense woods with fine texture and maximum dimensional response would present a most difficult surface for paint-layer survival.

Variation of wood structure, as found in some species, presents additional complications. In uneven-grained woods, for example, the difference between earlywood and latewood is a crucial element, especially as related to orientation of growth-ring emergence at the surface. In

even-grained conifers such as southern yellow pine or redwood, the poorer adhesion and survival of paint on latewood results in dramatic surface effects of paint failure. On flatsawn surfaces, denser and stronger latewood emerges at the surface in relatively wide and irregular bands, presenting larger continuous areas of exposed tissue surface, which is most unstable. By contrast, quartersawn surfaces are dimensionally more stable, and the latewood is exposed in narrow bands of tissue limited in width to the thickness of the latewood, and regularly interspersed with earlywood. Paint films with greater adherence to earlywood bands are better able to maintain integrity across the narrow strips of latewood and thereby survive more successfully on radial surfaces. This is dramatically apparent in woods with characteristically narrow latewood, such as western redcedar (*Thuja plicata*).

Among hardwoods, a somewhat opposite pattern of behavior results in higher density ring-porous species that have particularly uneven grain (oak or ash, for example). As such wood picks up moisture, the denser, more unstable latewood swells at will, expanding into the earlywood and crushing the weaker earlywood vessels. The effect is especially apparent in relatively fast-grown wood with fairly wide bands of latewood. In thicker material where moisture variation is concentrated at surfaces and the surface response is restrained by the unaffected wood below the surface, compression shrinkage manifests itself as concentrated damage to earlywood layers. On surfaces of painted ring-porous wood, the failed bands of earlywood are a common sight. In sharp contrast, ring-porous woods that have not been subject to extreme moisture variation may show greatest wear and failure of paint on latewood surfaces, with the greatest survival of paint where there was greater volume retention originally in the earlywood.

Some species have chemical compounds that may have an effect upon painted surfaces. Conifers in certain genera of the pine family (Pinaceae—e.g., pines, spruces, larches, and Douglas-fir) have resin canals. The resin or pitch contained in these resin canals may bleed through certain paints, possibly resulting in darkened or yellowish dots or spots in the paint layer. In these same woods, excessive resin may be produced, which saturates surrounding cells and results in areas called *pitch streaks*. When such areas of wood with excessive pitch are painted over, the paint may be discolored by bleed-through of the pitch. Excessive pitch routinely occurs in the area of tree-branch bases, so knots in exposed wood surfaces are characteristically the source of discoloration of paint if not primed with a sealer. The contents of parenchyma cells and other heartwood extractive materials may be the source of paint discoloration, such as the dark, blotchy discoloration that can emerge on painted cedar or redwood. The extractives of cell content of some woods—such as teak, rosewood (*Dalbergia* spp.), or lignum vitae—may be oily in nature, and surfaces of such woods may be self-contaminated and resist proper bonding of paint films.

---

## Reference

- Hoadley, R. Bruce  
 1980 *Understanding Wood: A Craftsman's Guide to Wood Technology*. Newton, Conn.: Taunton Press.

# Paints Based on Drying-Oil Media

David Erhardt

THAT CERTAIN PLANT AND SEED OILS harden to form solid, transparent films has been known for well over a thousand years. The earliest uses of these drying oils seem to have been as varnishes or coatings, but the incorporation of inorganic pigment or filler to form an opaque layer of paint must have followed soon after. Early examples of oil painting have been found, for example, in tenth-century objects from Japan (Uemura et al. 1954; Hirokazu 1961) and twelfth-century Norwegian altar frontals and polychromy (Plahter 1983, 1984), although these methods were relatively isolated until oil painting techniques were adopted throughout Europe in the fifteenth century.

---

## History of Oil Processing

Used from earliest times as sources of heat, food, and illumination, oils were expressed from crushed seeds or plant material by various methods. The bag press, in which a bag of crushed seeds was twisted to force out oil, was developed five thousand years ago in Egypt. The beam press, screw press, and wedge press followed. Each involved the use of leverage to compress bags of seeds.

Though the early extraction processes were inefficient, the cold-pressed oils they produced were relatively pure. Processing of the oil for use in a varnish or paint might consist of washing with water or allowing the oil to sit (often in the sun) so that extraneous material, such as protein or mucilage, could settle out. This *tanking* or sun refining also bleached and thickened the oil, and the resulting *sun-thickened* oil was regarded as the best quality material for artists' use. Oil also could be thickened by heating, often in lead pots. Direct heating at high temperatures (up to 260 °C) produced a thickened, partially polymerized, and darker oil. The formation and dissolution of lead salts during heating in lead pots (or the simple addition of lead compounds or pigments) resulted in an oil that dried quickly to a hard film, although it was darker and tended to yellow more than oil without such *driers*.

The craft of producing and painting in oil was well developed in Europe by the mid-sixteenth century, and few changes occurred during the following two hundred years. Almost the entire process of producing paint (grinding pigments, mixing paint) was conducted in the artist's studio. Raw materials (oil, bulk pigments) were purchased individually, and the quality of each could be assessed before the paint was produced. The

entire process of producing paint, and indeed the production of paintings, was often conducted according to a formalized routine.

References to heating the seeds before or during crushing appeared in the eighteenth century. References to the refining of the oil also became more common during this period. Heating increases the efficiency of oil extraction—raising the yield from approximately 20% to 28%, in the case of linseed oil—but also removes more extraneous material from the seeds. The resulting oil contains a larger proportion of contaminants and is inferior to cold-pressed oil unless refined to remove the impurities. The impetus for more efficient extraction methods coincided with the industrial and scientific revolutions. Growth in the manufacture of machines, vehicles, and metalwork requiring protective coatings necessitated a large increase in the amount of paint produced. To meet this need, efficient, large-scale methods for preparing painting materials were developed.

Hydraulic presses were introduced in the late eighteenth century. While more efficient in expressing oil from seeds, they tended to heat up during use. The first pressings of the day were considered the best quality and often were reserved for the highest grade paint. Later pressings, including repressings of the combined seedcakes, yielded oil that was of lower quality but still satisfactory for commercial quality paint after refining. Acid refining was introduced in 1792, possibly in response to the increase in hot pressing.

The introduction of premixed paste colors in 1793 represented a significant change. Prior to this time, artisans mixed their own paints, using dry pigments and oil, a task requiring considerable time and training. The new paste colors, however, consisted of pigments wetted with a minimum of oil. These colors could be brought quickly to the proper consistency simply by adding more oil. Painting became more portable than before, and more accessible to those who had not learned the craft of paint making. Most important, paint now became a commercial product. Control of the product shifted to industry, as the artist or artisan no longer selected or mixed the raw materials. Manufacturers developed formulations amenable to large-scale production and mechanical mixing. Considerations other than those of the artist or craftsman—such as shelf life, packaging, and production efficiency—were now taken into account.

Developments in drying-oil production and paint manufacture continued through the nineteenth century and into the twentieth. Heating prior to or during pressing became common. Syringe tubes containing premixed paints were introduced in 1840. This was followed in 1845 by tin tubes, a packaging form still standard today. Solvent extraction, first proposed in the 1840s, was not immediately adopted as a production method because of problems with the process and the lack of a source of cheap, suitable solvents. This method became more practical in the twentieth century with the development of the petroleum industry as a range of cheaper, more highly refined solvents became available (including nonflammable chlorinated solvents) and as problems of residual solvent remaining in the oil were solved. The screw expeller, introduced in 1903, was able to extract oil in a continuous process, but produced so much heat during use that no oil produced by it could be considered “cold-pressed.” Steam jacket heating replaced fire boiling or direct heating, so that lower controlled temperatures (less than 100 °C) could be used for postextraction processing to produce a thickened *stand* oil.

Alkali refining was introduced in 1923. This produced a very clean oil, but one that did not wet pigments well, and therefore often required the use of additives for the satisfactory preparation of paint. Currently, virtually all oil is obtained from heated seed using solvent or expeller extraction followed by alkali refining.

Differences in the physical, mechanical, optical, and chemical properties of dried oil-paint films often result from variations in the methods of pressing, processing, and refining oils, as well as the formulation and preparation of the paints. Many of these differences can be explained in terms of the chemistry of drying oils, the topic of the following section.

## Molecular Structure and Chemistry of Drying Oils

### Triglycerides

Oils and fats are both chiefly composed of chemicals known as triglycerides. Triglycerides are esters, compounds that result from the chemical combination of an alcohol and an organic acid, with the loss of water. In a triglyceride, the alcohol component is glycerol (also called glycerin), which has a molecular structure with three alcohol functional groups. This polyfunctional nature allows glycerol to combine with three fatty acid molecules, hence the name *triglyceride* (Fig. 1). Mono- and diglycerides are also possible, in which glycerol combines with only one or two fatty acids, leaving two or one of the alcohol groups unreacted.

Although chemically similar, the various oils and fats differ considerably in their properties. Melting point is a primary physical distinction: at room temperature, oils are liquid, and fats are solid. Oils also differ in their ability to “dry” and form solid films, a measure of their suitability as paint binders.

These and other differences result from the facts that (1) there are several fatty acids that can react with glycerol to form triglycerides;

Figure 1  
Molecular composition of a triglyceride formed from glycerol. Glycerol, a trifunctional alcohol, can react to form ester linkages with up to three fatty acids. The properties of the resulting triglyceride are determined by the specific combination of fatty acids it contains.

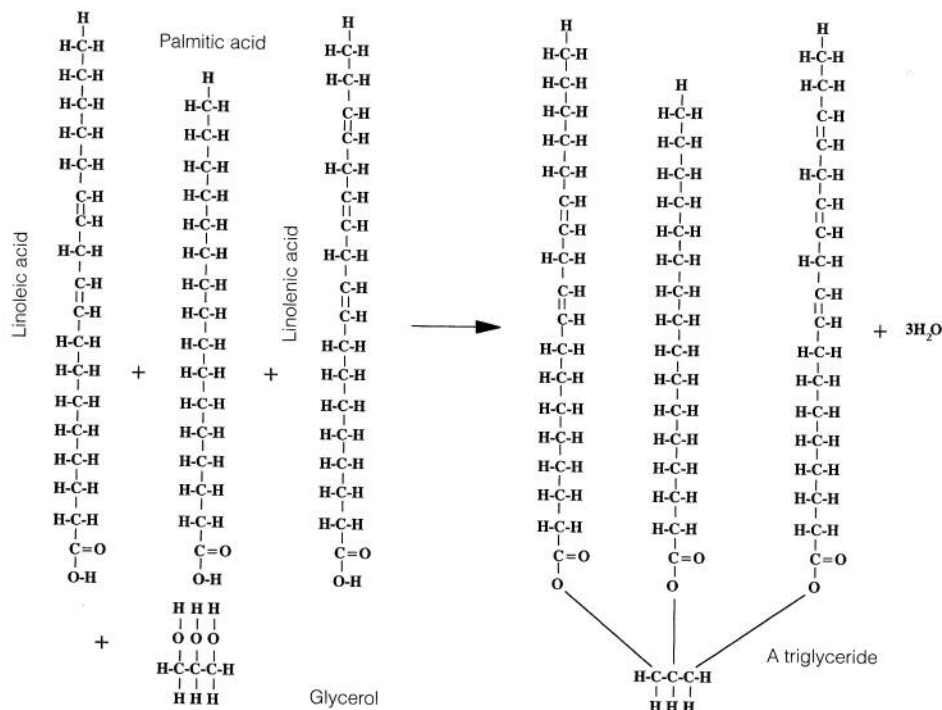



(2) there are even more ways to combine one, two, or three of these fatty acids within a triglyceride; and (3) each oil or fat may consist of several different triglycerides, with the types and distribution determining the overall characteristics of the mixture.

### Fatty acids

Fatty acids consist of a carboxylic acid group ( $-\text{COOH}$ ) at the end of a long carbon atom chain (usually of the straight-chain hydrocarbon type, although some contain branches or functional groups such as alcohols). In general, fatty acids differ in two basic ways: the total number of carbon atoms in the molecule, and the number (and position) of carbon-carbon double bonds ( $\text{C}=\text{C}$ ). Most fatty acids contain an even number of carbon atoms between twelve and eighteen, with eighteen being the most common. If all of the carbon-carbon bonds in the chain are single bonds, the fatty acid is referred to as *saturated*. *Unsaturated* fatty acids have one (monounsaturated) or more (polyunsaturated) carbon-carbon double bonds. The carbon atoms in the chain are numbered consecutively, starting with the carboxyl carbon atom. The locations of double bonds are indicated by the lower number of the two carbon atoms of the double bond. Most unsaturated fatty acids have the first double bond at carbon 9 (C9), with succeeding double bonds at C12 and C15. Fatty acids in this regular series are designated by the number of carbon atoms followed by the number of double bonds. The sixteen- and eighteen-carbon saturated fatty acids are palmitic acid and stearic acid, denoted by the figures 16:0 and 18:0, respectively. Oleic, linoleic, and linolenic acids are the eighteen-carbon acids with one, two, and three double bonds, respectively (18:1, 18:2, and 18:3). The reaction of three of these acids with the alcohol groups ( $-\text{OH}$ ) of glycerol to form ester groups ( $-\text{COOC}-$ ) is illustrated in Figure 1. The resulting compound is a triglyceride.

### The composition of oils

Each oil is composed of a mixture of triglycerides, as well as small amounts of mono- and diglycerides, free fatty acids, and other compounds. While it is fairly difficult to identify and quantify the individual triglycerides present, it is relatively easy to convert triglycerides to their component fatty acids and then identify and quantify them. Although factors such as climate, soil composition, and variations within plant species can affect the distribution of fatty acids, oil composition is often relatively consistent for oil from a particular source, such as linseed or walnut. Thus, differentiation of many oils by their fatty acid composition is possible, although less so for aged oil films. Tables of the composition of oils known to have been used in artists' materials have been published (Mills and White 1994; Erhardt et al. 1988). The composition of an oil determines whether it is a liquid or a solid (i.e., a *fat*) at room temperature. High proportions of the longer (sixteen carbon atoms or more), saturated fatty acids result in a melting point above  $25\text{ }^{\circ}\text{C}$  (a solid). The shorter fatty acids (fourteen carbon atoms or fewer), and the longer unsaturated ones with bends in the carbon atom chain produced by the rigid double bonds, do not pack and interact as well and remain liquid at room temperature. In general, fats contain high percentages of longer,

saturated fatty acids, while oils are more unsaturated and/or contain larger proportions of shorter fatty acids.

---

## Chemistry of the Drying Process

The primary sites of reaction in triglycerides are the ester linkages and double bonds. Reaction of the ester linkages is generally slow, except under acid or alkaline conditions or in the presence of certain enzymes (lipases), and is discussed in the section on degradation that follows. The double bonds can undergo a number of reactions that result in the formation of bonds connecting the glyceride molecules (cross-linking). This thickens and eventually hardens the oil. The same type of reaction, or further reaction of the products initially produced, can result in the chemical breakdown of the polymeric matrix of the dried oil and the eventual deterioration of the paint film.

### Polymerization reactions

Polymerization of an oil involves reactions resulting in chemical bonds linking many oil molecules together. This converts an oil from a liquid consisting of individual triglycerides into a more or less rubbery solid in which the oil molecules have combined to form an interconnected three-dimensional lattice. Such reactions occur primarily between the most reactive fatty acid groups at their double bonds, specifically those with two or three double bonds (most commonly linoleic and linolenic acids). If at least two such cross-links form per triglyceride molecule, the reactions lead to a fully cross-linked network; thus, drying oils are those in which at least two-thirds of the fatty acids are polyunsaturated. Non- and semidrying oils consist of more than one-third saturated and monounsaturated fatty acids. The reactions that constitute the drying process can be separated into two basic types—oxidative and thermal (or nonoxidative).

#### Oxidative polymerization

When a drying oil is laid out as a thin film, oxidation of the polyunsaturated fatty acids begins to occur. This oxidation leads to reactive products that then react with the double bonds of unsaturated fatty acids in other triglyceride molecules, forming chemical bonds that link the triglycerides together. This can occur via a free-radical chain-reaction mechanism in which an initial oxidative step leads to the linking (polymerization) of a number of triglyceride molecules. Reactions of this kind also lead to the formation of cross-links between triglyceride polymer chains. The process is not a simple one, and a number of different reactions are possible. The reader is referred to Mills and White (1994) and Wexler (1964) for a more detailed discussion of the mechanism and reactions. Oxidative cross-linking results in an uptake of oxygen by the oil film (around 10% or so, by weight) and a corresponding increase in volume (and possible wrinkling). The dried oil film contains a number of carbon-oxygen-carbon cross-links, as well as other oxygen-containing functional groups. The oxygenated sites are prone to further oxidation, discussed later under degradation processes. It should be noted that not all of the oxidative reactions lead to polymerization or the formation of cross-links; scission reactions can occur, breaking the fatty acid chain and yielding reaction products smaller than the original

fatty acid. The exact size of the products depends on the position at which the scission occurs. The major product is azelaic acid, a nine-carbon dicarboxylic acid (diacid), that results from oxidation of a double bond at C9, which is the double bond closest to the carboxyl carbon in most unsaturated fatty acids of glycerides. Most of the azelaic acid is still attached to the oil matrix through the original ester linkage of the glyceride, and is found during analysis only if this linkage is broken by hydrolysis, a reaction that is the reverse of the ester formation (esterification) reaction shown in Figure 1. Other products include the eight- and ten-carbon diacids, as well as even smaller amounts of monocarboxylic acids. Some of these compounds can also be produced by oxidation of the oil film that occurs after the drying process is complete.

### Thermal polymerization

Polymerization reactions can also be initiated thermally, and oils often are prethickened by heating. If oxygen is present, the reactions are probably much the same as for unheated oils. Blowing oxygen through an oil during heating thickens it and reduces the subsequent drying time. “Blowing” can force the drying of oils that would otherwise be only marginal drying oils.

If oxygen is not present, however, a very different set of reactions takes place (see Mills and White 1994 or Wexler 1964 for more details). One type of reaction involves the rearrangement of the position of double bonds to more reactive configurations (such configurations occur naturally in tung oil, one of the better and faster drying oils). The fatty acid groups with these more reactive double-bond positions can undergo direct addition to unsaturated fatty acids of other triglyceride molecules in the absence of oxygen. The resulting *stand* oils contain primarily carbon-carbon cross-links. While these thickened oils take up some oxygen in the final phases of drying after they are spread out, the amount of oxygen (about 3% by weight) and increase in volume are less than for oxidatively dried films. Fewer oxygenated sites in the resulting film means fewer sites prone to further oxidation. This resistance to oxidation causes stand oil films to be more durable and less prone to yellowing.

### Effects of additives on the drying process

The drying process can be affected by substances added to the oil. Some materials, such as lead and cobalt driers, are added specifically for their effect on the drying process. Substances added for other reasons, such as pigments, can also affect the drying of oils. The effect is usually due to a modification of the oxidation process. Some compounds speed up (catalyze) the oxidation process, while others inhibit it or interrupt the chain reactions that produce drying.

#### Oxidation catalysts

Some materials, especially compounds containing metals that can exist in more than one oxidation state, tend to catalyze the oxidation process. Lead, manganese, and cobalt—in that order—show an increasing ability to speed up the drying rate of oils. Some compounds of such metals have been commonly used as pigments, but could also be added specifically for their effect on the drying process. Only small amounts are required. Heating oil in a lead pot results in enough dissolution of lead to have the

desired effect (presumably by reaction with free fatty acids to form lead soaps that can dissolve in the oil). Alternatively, oil-soluble metal salts of organic compounds (resinates, naphthenates, fatty acid soaps) can be added directly to the oil.

#### Oxidation inhibitors

A number of naturally occurring organic compounds can function as antioxidants or inhibit oxidation reactions. These function either by reacting preferentially with oxygen initially or by reacting with the intermediates formed during the drying process and interrupting the free-radical chain reaction. Phenols are such a class of compounds and are found in a number of pigments, such as bitumen, carbon black, and Vandyke brown. Oils containing such pigments may dry very slowly or only after a significant delay, when most of the inhibitor present has reacted, or not at all. Larger than usual amounts of oxygen may be taken up, resulting in greater expansion and wrinkling. Drying oils themselves contain small amounts of phenolic compounds that may be responsible for an initial delay in the drying process.

#### Rate of the drying process

The drying process of oil paints runs to completion fairly quickly (with the exception of those containing inhibitors). Oil films gel and become dry to the touch usually within days, and they are reasonably hard and can be varnished within a matter of months. Essentially, all of the polyunsaturated fatty acid groups in the triglycerides disappear within a few years. Their reaction (usually to form bonds with other triglycerides) means that all of the triglycerides become bound up in the polymeric matrix. Indeed, the author found that exhaustive extraction of a three-year-old linseed-oil film yielded no di- or triglycerides and only hints of monoglycerides, possibly of the unreactive saturated fatty acids. Physical data also suggest similar time periods for the completion of the drying process. Oil films of different thicknesses prepared from the same paint differed in their mechanical properties after four years, suggesting that the rate of drying is slower at greater depths within the films. The differences between films of varying thickness (up to 0.38 mm) had disappeared after thirteen years (Mecklenberg and Tumosa 1991). Other reactions, however, can continue to occur. These reactions result in relative, rather than fundamental, changes in the physical and chemical properties of dried oil films.

---

#### Degradation of the Dried Oil Medium

The ester linkages and now-reacted double bonds remain reactive sites in a dried oil matrix. Consequently, an oil-paint film is subject to continuing changes and eventual degradation caused by further oxidation, hydrolysis, or external effects (i.e., cleaning, varnishing, or environmental factors). These changes can affect both the appearance of the film and its sensitivity to solvents and other cleaning agents. In general, older oil films tend to be darker (as discussed above) and more resistant to solvents, and to increase in hardness and refractive index. Extremely degraded oil films, though, can soften and become sensitive to solvents because low molecular weight components, present in increasing amounts, function as plasticizers and are sensitive to leaching by cleaning. Loss of these low-molecular-weight

components through volatilization, blooming, or solvent leaching may cause the paint layer to become stiffer and matte (dull or less shiny) and ultimately less coherent.

### Effects of continued oxidative reactions

The major class of continuing reaction in dried oil films is oxidation. The products resulting from initial oxidative cross-linking are prone to further oxidation, especially at the carbon atoms attached to oxygen. Certain pigments, chemical driers (metallic salts), and other paint additives may also contribute to further oxidation of the oil film. Continued oxidative reactions can result in an increase in weight because of the addition of oxygen, but they can also cause the eventual loss of weight. The breakage of cross-links and fatty acid chains yields the same types of smaller molecules that are produced during the drying process (e.g., azelaic acid can be found immediately after drying, and further aging produces increasing amounts). Weight loss occurs when these smaller molecules migrate to the surface and volatilize, are removed during cleaning, or are extracted into applied varnish films (Tsang and Erhardt 1992). Continued oxidation can eventually lead to softening and weakening of the oil film.

### Solvent sensitivity

Oxidation of a dried oil film results in an increase in the number of chemically reactive polar functional groups—such as the hydroxyl groups of alcohols and carboxyl groups of carboxylic acids—as well as the production of smaller molecules. These functional groups are more polar than the original hydrocarbon chains of the fatty acid groups because of partial charge separations in the carbon-oxygen bonds. The increase in polar groups should result in stronger interactions within the oil film due to the attractive forces between the partially charged polar groups. The presence of more polar groups also might be expected to shift the sensitivity of the oil film to more polar solvents. A study has shown, however, that while comparable oil-paint films containing lead white and raw sienna differed in their absolute sensitivity to a given solvent, the change in sensitivity with change in solvent polarity was similar for both films (Tsang and Erhardt 1992). Both the lead white and raw sienna films were most sensitive to the same solvents, but the lead white film, which should have been more oxidized, was less sensitive to all solvents, as shown in Figure 2. The practical effect was that the range of solvents with a significant effect on the lead white film was narrower. Nonpolar (low Hansen's solubility parameter) solvents that affected the raw sienna film had little effect on the lead white film, which required solvents closer to the center of its solubility range to achieve any significant effect. Some of the resistance of lead white films is probably due to the formation of insoluble lead salts, but these results indicated that oxidation will result, at least initially, in an oil film that is generally more resistant to solvents rather than in a film whose solvent sensitivity has shifted to more polar (higher Hansen's solubility parameter) solvents. To produce a significant shift in the center of the solubility range, therefore, may require more severe oxidation than that which occurs during normal aging.

### Density and refractive index

The increase in number of functional groups should have other effects. As a general—though not strict—rule, oxidation and an increase in the num-

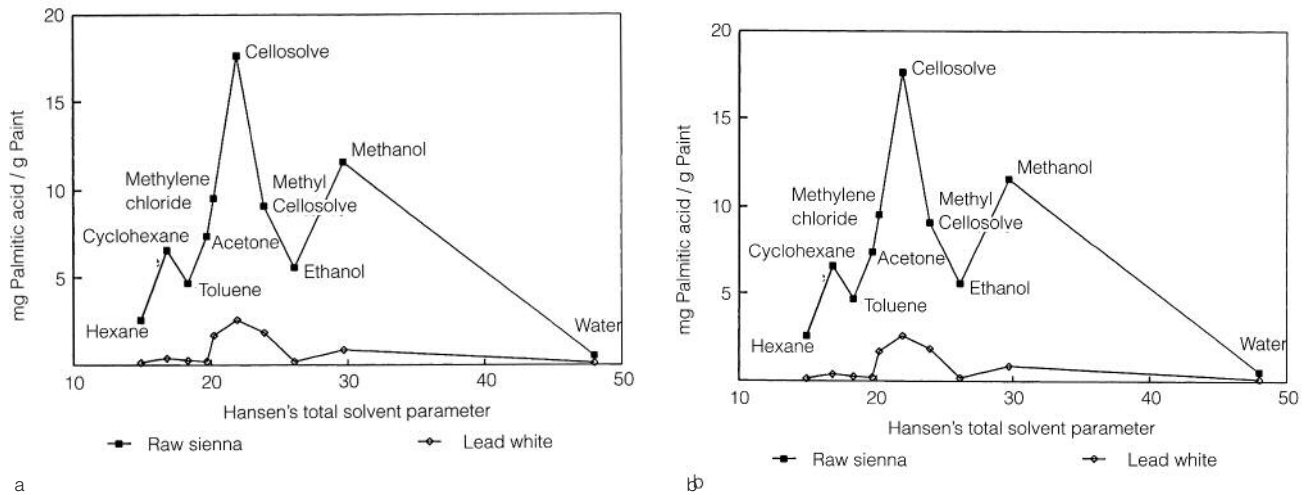

Figure 2a, b

Plots of the amount of palmitic acid extracted in six hours from oil paint samples versus Hansen's total solvent parameter for the solvent. One plot (a) shows that the overall solvent sensitivity of lead white is much less than that of raw sienna; and the second (b), in which the scale of the lead white plot is expanded, shows that the solvent sensitivity is not shifted, but simply reduced (from Tsang and Erhardt 1992:88).

ber of functional groups should result in a greater density and a higher index of refraction. The index of refraction of linseed oil is about 1.48 (Gettens and Stout 1966) but rises during the drying and aging processes to values as high as 1.57 for aged films (Feller 1957). The increase in index of refraction reduces reflection at oil-pigment interfaces and allows light to penetrate paint films more deeply (de la Rie 1987). This helps to explain the phenomenon of pentimento, in which underdrawing or overpainted design becomes visible as the covering layer grows increasingly transparent. At the same time, the presence of more functional groups (along with increased density) should result in a harder film.

#### Yellowing of dried oil media

Yellowing of oil-paint films is also related to the oxidative process, although the exact mechanisms are still not clear (see Mills and White 1994 for a discussion of proposed mechanisms). Highly unsaturated drying oils (those with the most linolenic and related acids) are particularly prone to yellowing. Thus, oils that dry best (the most highly unsaturated ones) also tend to yellow the most. Linseed oil is more unsaturated and dries better than either poppy-seed or walnut oil, but it yellows more. This is one reason that poppy-seed and walnut oils often were used to formulate lighter colored paints. There are numerous examples of paintings on which walnut oil was used in lighter colored areas, and linseed oil in areas with darker pigments, where yellowing of the medium has less effect on the appearance.

Proposed mechanisms for yellowing include *condensation reactions* (the formation of bonds between molecules with the loss of small molecules, such as water) of fatty acids oxidized at more than one position to yield quinone-type structures. Condensation reactions with nitrogen-containing compounds (amines)—either ammonia in the atmosphere or amines present in the oil (proteins, for example)—could also produce chromophoric groups, which are chemical structures associated with color.

Yellowing occurs more readily in the dark, and can be at least partially reversed by exposure to light. This yellowing–light-bleaching cycle can be repeated, although the bleaching probably is not a true reversal of the yellowing process. More likely, exposure to light promotes oxidation of

double bonds in the chromophores that are responsible for the color. The oxidation may initially yield compounds that are colorless, but such compounds may be capable of producing more colored compounds through further oxidation or condensation.

#### **Low-molecular-weight degradation products**

Continued oxidation may break the initial oxidative cross-links and fatty acid chains, resulting in the presence of smaller, mobile molecules in an aged oil film. These smaller molecules can act as plasticizers that tend to produce a softer film. These small components can be extracted from the oil film, however; thus, their presence tends to make the film more sensitive to solvents or other cleaning agents (Erhardt and Tsang 1990; Feller, Stolow, and Jones 1985; Erhardt and Bischoff 1994). Small molecules can migrate through the oil film and may appear as a bloom on the surface or, ultimately, volatilize. The loss of extractable material—either quickly, through cleaning, or slowly, through evaporation—can result in shrinkage and a stiffer and stronger film (see Mecklenburg, Tumosa, and Erhardt, herein).

The loss of material from a film often results in lighter color and a more matte surface. Voids in an oil film increase the scattering of light and reduce light-pigment interactions. If too much of the organic binder is lost and the pigment particles are no longer bound by the oil matrix, the surface becomes chalky and friable.

#### **Effects of continued hydrolysis**

Hydrolysis of ester linkages of glycerides in a dried oil is the reverse of the reaction presented in Figure 1. Water reacts with a glyceride to split the ester into its acid and alcohol components. Hydrolysis cleaves the ester group into the two functional groups (hydroxyl and carboxyl) from which it was formed, yielding an alcohol and a carboxylic acid, respectively. The alcohol (glycerin) is likely to remain attached to other fatty acid groups through ester linkages, thus persisting as part of the polymer matrix of the dried oil. Depending on its structure, the carboxylic acid may react to form bonds with other triglycerides, in which case it also remains part of the dried oil matrix. However, if the fatty acid is saturated and has not reacted with other triglycerides, or was unsaturated but has undergone a scission reaction, hydrolysis yields either the original saturated free fatty acid or scission products such as diacids, hydroxy acids, or short-chain fatty acids. These are no longer attached to the polymer matrix. Thus, hydrolysis produces effects similar to oxidation, increasing the number of functional groups, causing breaks in the polymer matrix, and producing low-molecular-weight degradation products.

#### **Effects of pigments, chemical driers, and other additives**

Pigments and other additives affect the degradation process in much the same way that they affect the drying process. Their main effect is to influence the process of oxidation, either catalyzing it or hindering it. Some pigments may catalyze photooxidation, speeding up the degradation of oil films exposed to light. Rasti and Scott (1980) examined the effects of a number of pigments on the photodegradation of oil films. Chemical driers (lead, manganese, or cobalt salts) continue to catalyze oxidative reactions in a dried oil film. Consequently, paints containing such driers are prone to yellowing and to hastened deterioration.

However, pigments and other additives may contribute to the degradation of oil paints through other mechanisms. Reactions with environmental pollutants may occur. For example, paint films containing lead white will darken when the pigment reacts with hydrogen sulfide to form black lead sulfide.

Interactions between the components of the oil and the pigments or other materials in the paint film may also take place. Oils generally contain up to a few percent by weight of free carboxylic acids, which can form salts with the metal ions of some pigments. These carboxylic acid salts are soaps, and their surfactant effect initially helps the oil to wet, disperse, and bind to the pigment.

The presence of these salts may contribute to the durability and the solvent resistance of some oil paints. Such is the case with lead white films, where the formation of lead salts of fatty acids (which tend to be insoluble in most aqueous and nonaqueous solvents) yields solvent-resistant oil-pigment bonds, and helps to immobilize otherwise mobile or volatile free fatty acids. Solvents cause less swelling and extract less material from lead white pigmented oil films than those containing, for example, raw sienna or vermilion.

By contrast, some pigments or other additives may lower the resistance of paints to solvents. Certain pigments are soluble or sensitive to water or other polar solvents. Consequently, oil paints containing such pigments (e.g., zinc oxide) will exhibit increased sensitivity to polar solvents. Incorporating soluble organic materials, such as resins or waxes, into an oil medium also greatly increases the solvent sensitivity of the resulting film.

Modern paints may contain other additives used to produce the properties required of industrial products. For instance, alkali-refined oils have low amounts of free fatty acids and may require added surfactants to wet pigments well and to keep oil and pigments from separating during the periods between manufacture, sale, and use. The long-term effects of these and other additives vary considerably.

#### Environmental effects

Environmental factors, such as changes in relative humidity (RH), also affect oil films. For example, high RH can essentially “reset” some of the hardening of oil films. Absorbed water causes swelling, which may disrupt the oil-pigment interactions or the ordering of the oil matrix that occurs over time. The disruption of oil-pigment bonds and the voids produced by loss of material can give the paint a matte appearance and lighter color as mentioned in the discussion of blanching.

#### Effects of oil processing

Modifications in oil processing affect the chemistry and composition of oils, which in turn influence the drying properties, durability, and degradation of paints. Table 1 summarizes these effects.

Cold pressing, a technique rarely used today, results in a clean, high-quality oil that produces very durable paint films. The more common practice of heating before or during oil extraction results in an impure oil requiring additional refining. Heating may also alter the oil chemistry, especially if oxygen is present or the temperature is too high, resulting in a less durable oil film.



Table 1 The chemical and practical effects of oil processing and treatment

Effects of oil refining and treatment		
Type of treatment	Chemical effect	Practical effect
Cold pressing	Removes oil and little else, without altering the oil	Clean, high-quality oil
Heating before or during oil extraction (includes most modern processes)	Increased amounts of protein, mucilage, etc., extracted compared to cold pressing	Postextraction refining is required
Addition of chemical driers (lead, manganese, cobalt salts)	Catalyzes oxidative processes (drying and deterioration)	Fast drying on exposure to air; less durable film; lead salts may darken on exposure to pollutants
Acid refining	Increased amounts of free fatty acids	Wets pigments well
Alkali refining	Reduced amounts of free fatty acids	May require addition of surfactant (such as aluminum stearate) to wet pigments
Heating after oil extraction in absence of oxygen ( <i>stand oil</i> )	Nonoxidative prepolymerization of oil, some precipitation of impurities; low temperatures (up to 100 °C) yield best quality; high temperatures (up to 260 °C) yield darkened oils	Hard, tough film that is less prone to oxidation; heated oil can be thick and difficult to work with; may require thinning with solvent before use
Heating after oil extraction with air blown through ( <i>blown oil</i> )	Oxidative prepolymerization of oil	Faster drying than unblown oil, but with similar chemistry; marginal drying oils can be used

Alkali refining, the method most often used to refine oils obtained using heat-extraction techniques, reduces the amount of free fatty acids in the oil, thereby decreasing the ability of the oil to wet pigments. To counteract this, soaps such as aluminum stearate are added to improve wetting and prevent the separation of oil and pigment.

Heating after the extraction process tends to cause impurities to coagulate and settle out. If oil is heated at moderate temperatures (up to 100 °C) in the absence of air, a nonoxidative prepolymerization takes place that results in a thickened *stand oil* that will form a hard, tough film resistant to oxidation.

More intense heat, however, can lead to darkening and decomposition. At high temperatures, bubbles form in the oil. While the oil appears to boil, the bubbles actually indicate the evolution of gases generated by decomposition. Such treatment is now rarely used, and “boiled” oil generally refers to oil with chemical driers added. These chemical driers, as stated previously, continue to catalyze oxidation even after initial drying, resulting in less durable films that are prone to yellowing. The lead from a drier present in an oil film can also react with pollutants to cause darkening.

Heating oil in the presence of oxygen (*blown oil*) results in much the same chemical processes as occur during air drying of oil films, but the resulting oxidatively prepolymerized oil dries quickly. This technique, however, does not produce an oil resistant to yellowing and further oxidation.

---

## Effects of Conservation Treatments

### Cleaning

The cleaning of oil-paint films can have several negative effects if it is not carefully carried out (see Mills and Smith 1990 for a number of articles on cleaning). Soluble material can be removed from the film, resulting in changes in both the optical and mechanical properties. The low-molecular-weight materials that are most easily extracted function as plasticizers, and their loss results in a stiffer film with a higher modulus of elasticity (see Mecklenburg, Tumosa, and Erhardt, herein). Loss of material also results in a blanched or matte appearance. Though a slight swelling of an oil film due to exposure to solvents is largely reversible, excessive swelling results in an irreversible disruption of the oil matrix and oil-pigment bonds. Resulting voids and disorder of the film can also produce a matte appearance even if no material is extracted. Such effects can sometimes be partially reversed by careful application of a solvent to achieve partial dissolution and reforming of the film.

Cleaning agents that affect pigments or oil-pigment bonds can have similar effects. This is especially true for polar solvent or aqueous mixtures. Partial dissolution of pigments (of zinc oxide by water, for example) also disrupts the oil film.

Cleaning agents that include nonvolatile solvents or reagents, such as soaps formulated from resin acids, may leave residues. Such cleaning agents may also extract material or disrupt an oil film but may not have the visible effects of volatile solvents, since the residues serve to fill in voids and darken the oil film, providing a saturated rather than matte appearance. A number of effects were studied as a function of the presence or absence of individual components of typical resin soap formulations (Erhardt and Bischoff 1994), however the long-term effects of such residues have not been studied.

### Varnishing

Varnishing serves two primary purposes: to improve the appearance of the paint film and to protect it. A varnish layer serves to fill in surface voids and defects, thereby reducing the scattering of light and increasing light-pigment interaction (De la Rie 1987). This is especially true of deteriorated or damaged paint films in which the surface is no longer smooth or uniform. The resulting darker, saturated appearance is more typical of a fresh, intact film. Matting agents such as wax or fumed silica may be added to varnishes to make them less shiny or reflective, depending on the final effect desired.

Varnishes protect paint films physically from dust and abrasion. They absorb little visible light (unless quite thick and yellowed) and may absorb some incident ultraviolet (UV) light, but they cannot provide substantial protection against UV light unless a UV absorber is present in the varnish. Varnishes may not prevent oxidation directly since the diffusion of oxygen through a varnish film is still faster than any oxidation reactions that might consume it. Instead, they inhibit the reaction indirectly by reducing the amount of photooxidation that takes place.

As noted above, the removal of varnishes, as well as other non-original layers and accretions, has the potential of significantly altering the paint film. The application of a new layer of varnish also must be performed carefully since the solvents used in the application can affect the paint film, as well. Solvent in the applied varnish can diffuse into and swell

the paint layer, dissolve soluble material, and transport this material into the varnish layer as the solvent eventually diffuses to the surface of the varnish and evaporates (Tsang and Erhardt 1992). The presence of oil components in the varnish layer may cause confusion if the varnish layer is subsequently analyzed, possibly causing a pure resin to be identified as an oil-resin varnish. Mixing of material and blurring of the paint-varnish interface during varnish application can complicate determination of the proper extent of subsequent varnish removal.

---

## Analysis of Aged Drying-Oil Films

Analysis of aged drying-oil films depends on a knowledge of their original composition and on the chemical changes that occur during processing, drying, and aging. Because aged drying-oil films are polymeric, they generally are hydrolyzed as the first step in analysis. The hydrolyzed film contains three important classes of materials: (1) unreacted fatty acids (predominantly the saturated ones); (2) degradation products; and (3) higher-molecular-weight components resulting from the cross-linking of the unsaturated fatty acids. At present, constituents of the first two groups are readily identified and quantified (Mills and White 1994; Erhardt et al. 1988) and yield information about the original oil and its processing. Gas chromatography (sometimes combined with mass spectrometry) is the optimal method for the analysis of fatty acids and their degradation products, and of many common paint additives, such as waxes and resins.

Because the saturated fatty acids are essentially unreactive, they are present in the dried film in the same ratios as in the original oil. Although analysis of the saturated fatty acids alone provides less information than could be obtained from the original oil, it is still sufficient to identify a number of important oils. The three important drying oils of Western European oil painting (linseed, walnut, and poppy seed) differ, with little overlap, in their ranges of the ratio of palmitic to stearic acid (Mills and White 1994; Mills 1966). Even in more obscure cases, an oil may be identified if possible sources are known and samples of the oil or results of previous analyses are available (Erhardt and Firnhaber 1987).

The degradation products provide information about the processing and aging of the oil, as well as its identity. The amount of azelaic acid (the C9 diacid) in drying-oil films increases slightly as they age. Films more than about a hundred years old tend to contain amounts of azelaic acid equal to or greater than the amounts of the unsaturated fatty acids. This is in contrast to nondrying oils, such as egg, that tend to contain smaller amounts of azelaic acid even when very old. Egg contains fewer unsaturated fatty acids that can degrade to azelaic acid; thus, egg can be differentiated from a drying oil such as walnut, even though their palmitate-to-stearate ratios overlap in range, by the lower amount of azelaic acid in egg. (Other methods of analysis can also be used since egg yolk, even without albumen, is about one-third protein.)

Azelaic acid is the predominant degradation product. It results from oxidation at the C9 double bond of unsaturated fatty acids, which is the most common position of the initial double bond. Less common acids or reactions can produce other diacids, such as the C8 and C10 compounds. Thermal rearrangement of double bonds of drying oils before oxidative polymerization increases the proportion of the C8 and C10

diacids relative to azelaic acid. Thus, larger than normal amounts of the C8 and C10 diacids are indicative of a heated, or *stand*, oil. Additives or processes that catalyze oxidation will increase the rate of degradation processes leading to diacids but should have little effect on the relative amounts of the different diacids. Thus, blown oil or oil with added driers cannot necessarily be differentiated from unprocessed oil by comparing the relative amounts of the diacids. Driers such as metal salts can be detected by other methods of analysis.

---

## Conclusion

Many of the physical, chemical, and optical properties of oils, and the oil paints prepared from them, are affected by the processing and treatment of the oil. Historically, the processing of oil has been determined by the increasing importance of industrial concerns: speed, efficiency, and marketing and commercial factors. Many of the changes have adversely affected the qualities of oils that are important to artists or have resulted in the need for further refining or the use of additives in an attempt to regain some of the properties of cold-pressed, high-quality oil. The effects of the differences in oil-processing methods can be described in terms of their effects on the chemistry of the oil, which in turn affect the drying properties, strength, durability, optics, and permanence of the resulting oil film. Aging of oil films tends to produce contradictory effects. While oxidation is initially responsible for the drying of oils, continued oxidation results in degradation. Reactions that initially cause hardening may eventually soften the film if they continue. Differences in the composition of oils, as well as differences due to processing and aging, can be useful in the analysis and identification of oils.

---

## References

- De la Rie, E. R.  
1987 The influence of varnishes on the appearance of paintings. *Studies in Conservation* 32:1–13.
- Erhardt, D., and J. J. Bischoff  
1994 The roles of various components of resin soaps, bile acid soaps and gels, and their effects on oil paint films. *Studies in Conservation* 39:3–27.
- Erhardt, D., and N. Firnhaber  
1987 The analysis and identification of oils in Hawaiian oiled tapa. In *Recent Advances in the Conservation and Analysis of Artifacts*, comp. J. Black, 223–28. London: Institute of Archaeology.
- Erhardt, D., W. Hopwood, M. Baker, and D. von Endt  
1988 A systematic approach to the instrumental analysis of natural finishes and binding media. In *AIC Preprints: 16th Annual Meeting, American Institute for Conservation, New Orleans*, 67–84. Washington, D.C.: American Institute for Conservation of Historic and Artistic Works (AIC).
- Erhardt, D., and J. S. Tsang  
1990 The extractable components of oil paint films. In *Cleaning, Retouching and Coatings*, ed. J. S. Mills and P. Smith, 93–97. London: International Institute for the Conservation of Historic and Artistic Works (IIC).
- Feller, R. L.  
1957 Factors affecting the appearance of picture varnish. *Science* 125:1143–44.

- Feller, R. L., N. Stolow, and E. H. Jones  
1985 *On Picture Varnishes and Their Solvents*. Revised and enlarged edition. Washington, D.C.: National Gallery of Art.
- Gettens, R. J., and G. L. Stout  
1966 *Painting Materials: A Short Encyclopaedia*. New York: Dover Publications.
- Hirokazu, A.  
1961 Trays with flower-and-bird designs in litharge painting. *Museum* (Tokyo) 128:19–21.
- Mecklenburg, M. F., and C. S. Tumosa  
1991 An introduction into the mechanical behavior of paintings under rapid loading conditions. In *Art in Transit: Studies in the Transport of Paintings*, ed. M. F. Mecklenburg, 137–71. Washington, D.C.: National Gallery of Art.
- Mills, J.  
1966 The gas-chromatographic examination of paint media, part 1: Fatty acid composition and identification of dried oil films. *Studies in Conservation* 11:92–106.
- Mills, J. S., and P. Smith, eds.  
1990 *Cleaning, Retouching and Coatings*. London: IIC.
- Mills, J. S., and R. White  
1994 *The Organic Chemistry of Museum Objects*. 2d ed. London: Butterworth-Heinemann.
- Plahter, U.  
1983 Norwegian easel paintings from the period 1250–1350. In *La pittura nel XIV e XV Secolo: Il contributo dell'analisi tecnica alla storia dell'arte*, ed. H. W. van Os and J. R. J. van Asperen de Boer, 73–88. Bologna: Cooperativa Libreria Universitaria Editrice Bologna.
- 1984 The crucifix from Hemse: Analysis of the painting technique. *Maltechnik Restauro* 1:35–44.
- Rasti, F., and G. Scott  
1980 The effects of some common pigments on the photo-oxidation of linseed oil-based paint media. *Studies in Conservation* 25:145–56.
- Tsang, J. S., and D. Erhardt  
1992 Current research on the effects of solvents and gelled and aqueous cleaning systems on oil paint films. *Journal of the American Institute for Conservation* 31:87–94.
- Uemura, R., T. Kameda, K. Kimura, D. Kitamura, and K. Yamasaki  
1954 Studies on the Mitsuda-e, a kind of oil painting (in Japanese). *Scientific Papers on Japanese Antiques and Art Crafts* 9:15–21
- Wexler, H.  
1964 Polymerization of drying oils. *Chemical Reviews* 64(6):591–611.

# Tempera and Other Nondrying-Oil Media

*Richard Newman*

**A**LTHOUGH DRYING OILS are the major binding medium on many of the painted wooden artifacts discussed in this book, numerous other natural binding media are of historical importance. This article provides an introduction to animal and fish glues, egg white and yolk, casein, plant gums, plant resins and shellac, and waxes. Lacquer, a natural material widely utilized in China, Japan, and surrounding countries, has been discussed in a recent publication (Brommelle and Smith 1988). Other materials have been used by various cultures but cannot be discussed here due to space limitations; a recent bibliography can be consulted for references to some of these (Hansen, Walston, and Bishop 1994).

Binders are discussed here according to general composition, beginning with those made up entirely of proteins (animal and fish glues, egg white) or containing substantial amounts of proteins (egg yolk, casein); followed by those made up of carbohydrates (plant gums), natural resins and shellac (quite variable in composition, although most contain related groups of compounds), and waxes (also quite variable in composition, but containing some similar compounds). The section on each binder gives examples of its use, descriptions of sources, chemical composition, analysis, and degradation.

Comments on degradation focus mainly on chemical changes. Because paints are mixtures of pigments and binders, degradation is only partially determined by the nature of the binder. Many paints based on the binders discussed in this chapter are very fragile; consequently, their susceptibility to physical or mechanical damage is generally a more important cause of conservation problems than chemical changes in the binders themselves.

The appendix at the end of this chapter introduces the binding media identification techniques referred to here, discussing their individual strengths and limitations. Table 1, in the appendix, summarizes the applications of specific techniques to individual media and particular types of samples. Abbreviations for instrumental techniques given in that table are used throughout the chapter.

---

## Protein-Containing Media

Proteins are an important constituent of four common media: animal and fish glues, egg white, egg yolk, and casein. Because their sources and behavior as paint media are quite different, each is discussed separately. However, since they all contain proteins, this section begins with a review

of the chemistry of proteins, aspects of degradation common to all proteins, and identification methods for proteins that can be applied equally well to all of the binders.

### Chemical composition of proteins

All living organisms contain proteins, which are polymers of amino acids. The structures of some common amino acids are shown in Figure 1. Peptides are polymers of as few as two amino acid molecules (dipeptides) or as many as several dozen (oligopeptides). By convention, peptides have molecular weights of 10,000 daltons (atomic mass units) or less; amino acid polymers of higher molecular weights are proteins. In proteins, individual amino acid molecules are usually chemically bonded to only two other amino acid molecules. Certain amino acids can form more than two bonds, and in some proteins these are bonded to more than two other amino acid molecules. The types and relative amounts of amino acids present in proteins differ widely, as does the molecular weight.

Some proteins are water soluble; in their natural state, they are highly folded structures that can be nearly spheroidal in shape (globular proteins). The proteins in egg white, egg yolk, and casein are of this general type. Other proteins occur in long, threadlike strands and are not water soluble. Examples are keratin (hair, wool, and feathers) and fibroin, which occurs in silk. One fibrous protein that has the unusual property of breaking down to form a solution when heated in hot water is collagen. It is found in tendons and connective tissues of animals and some fish, and it is the major component of animal and fish glue binders.

Animal and fish glues and egg white contain only traces of compounds other than proteins. Egg yolk and casein contain some proteins that are chemically bonded to carbohydrates or lipids, as well as substantial amounts of other compounds.

### Aging and degradation of proteins

Many proteins exist in very complex structures that can be affected, often in irreversible ways, by changing the acidity or alkalinity, by heating or other changes in their environment, or simply by evaporation of water. Changes in the original structure are called denaturation; if irreversible, these can greatly affect solubility. Some changes are physical, involving the physical structure; others involve weak (noncovalent) bonds. Thus, a protein that exists in its native state in a water solution may be totally insoluble after drying.

Proteins readily react with acidic solutions (hydrolysis). A small amount of hydrolysis rapidly reduces the molecular weight of a protein, weakening its binding abilities. Microorganisms, or even enzymes found naturally in some of the binders, can rapidly hydrolyze proteins; and individual amino acids may also undergo chemical reactions. The stability of amino acids varies considerably: some are stable indefinitely; others rapidly degrade under the same conditions. Egg white, egg yolk, and casein all contain relatively high levels of more readily oxidized amino acids than does animal glue (Karpowicz 1981)—although the by-products of oxidation of amino acids are not well known. To date, no studies have been done on whether chemical changes in particular amino acids are significant in the degradation of protein-bound paint.

Figure 1

Structures of some of the amino acids found in protein-containing media.

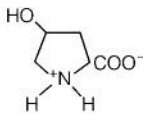
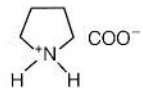
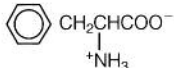
(+) Aspartic acid	Asp D	$\text{HOOCCH}_2\text{CHCOO}^-$   $^+\text{NH}_3$
(+) Glutamic acid	Glu E	$\text{HOOCCH}_2\text{CH}_2\text{CHCOO}^-$   $^+\text{NH}_3$
(-) Hydroxyproline	Hyp	
(-) Serine	Ser S	$\text{HOCCH}_2\text{CHCOO}^-$   $^+\text{NH}_3$
Glycine	Gly G	$\text{CH}_2\text{COO}^-$   $^+\text{NH}_3$
(+) Alanine	Ala A	$\text{CH}_3\text{CHCOO}^-$   $^+\text{NH}_3$
(-) Proline	Pro P	
(-) Leucine	Leu L	$(\text{CH}_3)_2\text{CHCH}_2\text{CHCOO}^-$   $^+\text{NH}_3$
(-) Phenylalanine	Phe F	

Amino acids can undergo *racemization*, a structural rather than a chemical change that takes place both in proteins and in the free amino acids. This is the basis for an archaeological dating technique applied mainly to bone and teeth (Aitken 1990:204–13); while racemization undoubtedly takes place in protein-bound paints, it is not known whether this produces any noticeable effect on the properties of a paint.

The simultaneous presence of proteins and carbohydrates in a paint or varnish can cause a type of deterioration reaction known as the *Maillard reaction* (Horie 1992). This reaction produces a volatile polymeric by-product that is brownish in color. One possible example of this has been cited (Stoner 1990).

Some interactions may occur between a protein binder and pigments. Acidic pigments in the presence of water, for example, may cause hydrolysis of the binder and/or may form salts of the breakdown fragments.

### Analysis of protein-containing binders

Most analytical schemes for protein-containing binders focus on the protein components. Stulik and Florsheim (1992) outline a general microchemical test for proteins. Another long-applied microchemical test involves detection



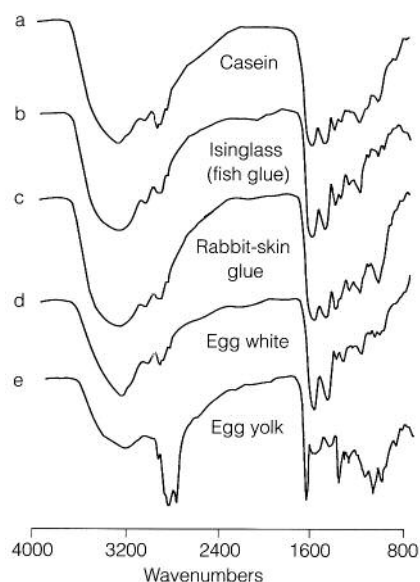

*Figure 2*  
Infrared transmittance spectra of some protein-containing materials. Note that the spectra are quite similar, with the exception of egg yolk, which contains a substantial amount of oil in addition to protein.

with ninhydrin (Feigl 1960:293–94). Proteins have been identified in paint cross sections by staining reactions: common visible-light stains are described by Martin (1977) and Johnson and Packard (1971); and fluorescent stains by Wolbers and Landrey (1987). While a method to distinguish between some of the different proteins with visible-light staining has been published (Martin), the primary use of the staining reactions is simply to indicate presence or absence of proteins.

A general instrumental analysis technique for proteins is infrared (IR) spectrometry (Fig. 2). Pyrolysis–gas chromatography (Py-GC) can verify the presence of proteins (Chiavari et al. 1993). Although it cannot always provide a positive identification of the protein present, Py-GC may help narrow down the possibilities. To date, amino acid analysis is most often used to identify specific proteins in binders (Halpine 1992a, 1995; Schilling, Khanjian, and Souza 1996; Schilling and Khanjian 1996). Thin-layer chromatography (TLC) has been frequently applied, but gas chromatography (GC) and high-performance liquid chromatography (HPLC) are better suited to quantitative analysis, which is necessary for definitive identifications. Egg white and egg yolk can be difficult to distinguish even by quantitative amino acid analysis, but all of the other protein binders are readily distinguished from one another because of substantial variations in relative amounts of the different amino acids (Fig. 3). Through the use of HPLC for the analysis of amino acids, the binder of the paint on a large group of wooden figures from the Middle Kingdom in Egypt (Fig. 4) was found to be bound with glue (Fig. 5). The amino acid profile of the nearly four-thousand-year-old binder did not differ substantially from that of modern collagen. Other tests that have been applied to distinguish particular protein binders from one another are noted in the following.

#### Animal and fish glues

Probably the most widely utilized binders historically are glues derived from animals. For example, animal glues were probably the main paint binder in the paintings of China and most other East Asian countries (Winter 1984). An early manuscript from India describes the use of buffalo-skin glue in wall paintings (Coomaraswamy 1934). Glue has long been assumed to have been a major binder in ancient Egyptian painting, and recent analyses have confirmed that this was quite common (Newman and Halpine 1994). Glue also was used for medieval illuminations and early European fabric paintings (Roy 1988).

Research from recent years suggests that mixtures of animal glue and other binders may have been used occasionally on panel paintings. Kockaert (1973–74) has postulated that an oil–animal-glue emulsion was utilized by late medieval Flemish painters, a medium with useful handling properties for the intricately detailed paintings for which these artists are known. In addition to its use as a paint binder, another common use on European and American painted objects was in gesso or ground layers.

**Chemical composition.** Animal glues are based on the protein collagen, the most common protein in animals, and are derived from white connective tissue in skin, bones, and tendons. Five distinct variants of collagen have been identified in vertebrates, although their overall amino acid compositions are quite similar (Lollar 1984). Collagen occurs in the skins of fish and is virtually the only component of the swim bladder of the sturgeon. In its native state, it is virtually insoluble. It exists in the form of a triple helix of three protein strands. Each strand, which contains

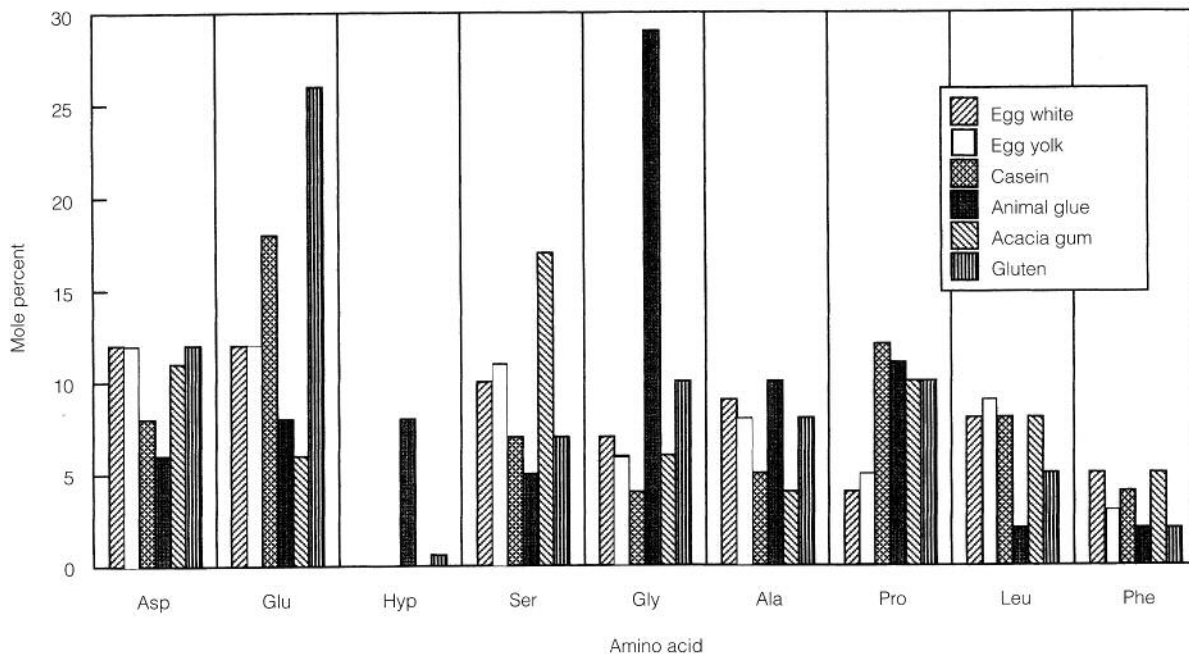

Figure 3 Amounts of some amino acids in a number of protein-containing binders and other non-proteinaceous materials. Asp, aspartic acid; Glu, glutamic acid; Hyp, hydroxyproline; Ser, serine; Gly, glycine; Ala, alanine; Pro, proline; Leu, leucine; Phe, phenylalanine. The first four materials contain substantial amounts of proteins, the last two only very small amounts of amino acids. (Sources of data: acacia gum, from *Acacia campylacantha*, Anderson, Hendrie, and Munro 1972:734; gluten from durum wheat, and all others from Halpine 1992b)

more than one thousand amino acid units, has a molecular weight of about 100,000 daltons. The strands are held together by hydrogen bonding and by some covalent bonds, the latter increasing with the age of the collagen. Collagen also contains a minor, chemically bound carbohydrate component (Traub and Piez 1971:272–73).

The unusual property of collagen that makes it useful as a binder is that it can be solubilized by heating in water. Current commercial preparation of collagen-based glues usually involves treatment with acid or alkali, which degrades the collagen rather than simply solubilizing it (Von Endt 1984). Thus, the molecular weights of the strands in a glue are often much lower than those of the strands in their native state; in fact, most commercial glues contain molecules with a wide range of molecular weights. Gelatin is quite similar to glue but is a purer material since it is manufactured under more stringent processing conditions and control than glues.

Figure 4 Painted wood model of a procession, Egypt, Deir el-Bersha tomb 10A, Middle Kingdom, Dynasty 11 (2061–1991 B.C.E.). Museum of Fine Arts, Boston (accession no. 21.326).



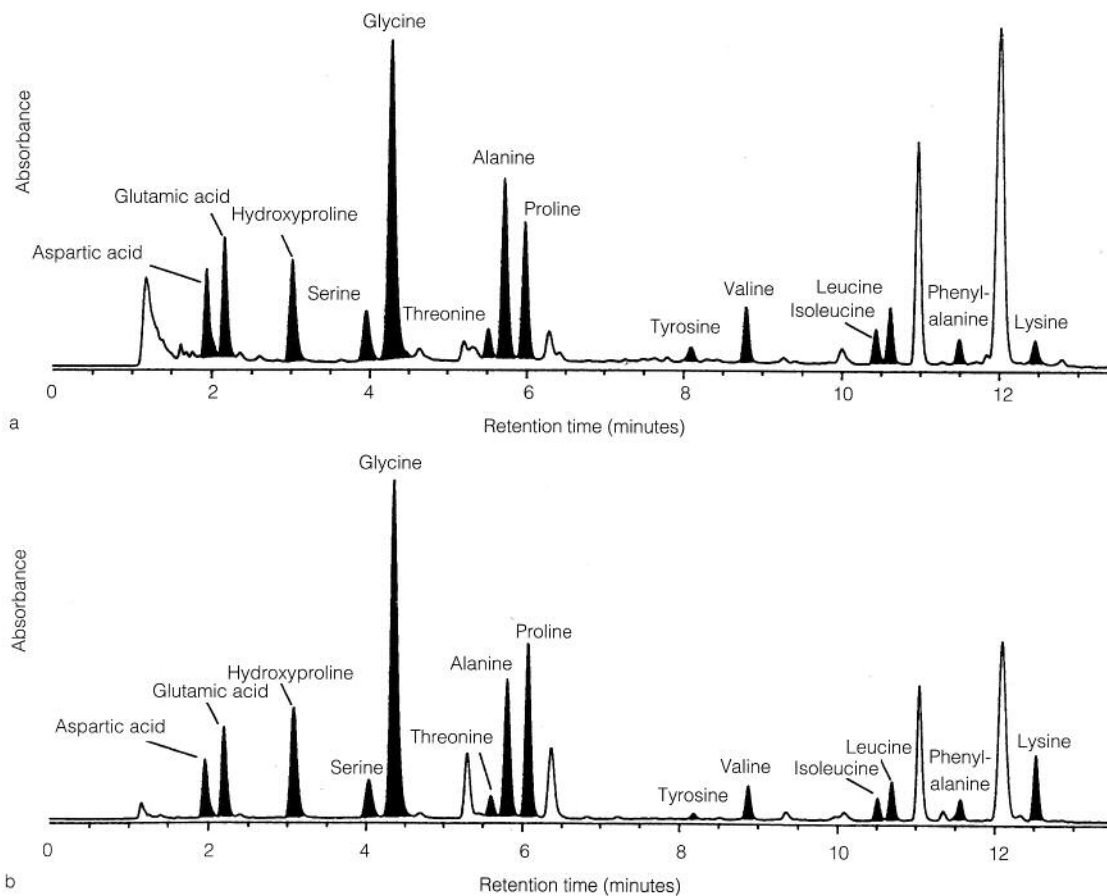

Figure 5a, b

Chromatograms (a) of a sample of black paint from a painted figure that comes from the same tomb as those shown in Figure 4; and (b) of collagen (the protein found in animal and fish glues). Analyses carried out by high-performance liquid chromatography; the paint and collagen samples were hydrolyzed and analyzed as phenylthiocarbamyl derivatives. Absorbance at 254 nm is plotted. (Source: Halpine 1991)

If a collagen solution is allowed to cool to around 30 °C, it will gel. As water evaporates, the gel forms a solid, which can be ground and readily dissolved by warming in water. The inconvenience of working with a warm solution of the binder can be overcome by allowing the solution to sit for a time and partially decompose. As an early medieval treatise stated, “after a few days it will stay liquid without heating. It may smell bad, but it will be very good” (Thompson and Hamilton 1993:13). The decomposition mainly results in further breakdown of the protein strands into smaller fragments that no longer gel at room temperatures. A dried gelatin film consists of collagen strands arranged in at least a somewhat orderly fashion, partly duplicating the original structure of the native collagen. The film readily absorbs water and loses strength in the process. Glue-bound paints are lean (i.e., the amount of binder is low relative to pigment), so the paint tends to be porous and matte. The ability of the three-stranded collagen molecules to stretch gives glue-bound paints a flexibility that egg-white paint (containing globular proteins) does not have.

**Analysis.** The ability of glue-bound paints to be solubilized in hot water sets them apart from most other protein-bound paints. Solubility, coupled with a positive result for protein, strongly suggests the presence of glue.

Hydroxyproline, which makes up around 10% of the overall amino acid units in collagen, is absent from the other common protein-containing binders, although it can be found in some other nonproteinaceous binders at low levels. A microchemical test for this amino acid has been described in the conservation literature, but the sample size is larger

than would typically be available (Collings and Young 1976). The amino acid composition of different genetic varieties of collagen varies somewhat. It has been claimed in one recent paper that fish and animal glues can be distinguished by quantitative amino acid analysis (Sinkai et al. 1992); but this should be more thoroughly investigated, since the variations are rather subtle.

Modern gelatins and glues are more highly processed than older glues. It has been noted that old glues contain small amounts of fatty acids (lipids), which are amenable to analysis by the same procedures as are applied to oil paints (Skans and Michelsen 1986; Mills and White 1987). This is a possible criterion for distinguishing between older and more modern glues.

### Egg white

The best documented use of egg white as a binder is in European manuscript illuminations (Thompson 1956:50–55). Several medieval treatises discuss the preparation and use of egg white as a binder, the preparation being carried out either by whipping or by taking up the white in a sponge and squeezing it out repeatedly until no froth forms.

There are no documented uses of egg white as a binder on painted wood artifacts. However, it has been suggested, although not proved by modern analyses, that egg white was utilized as a paint binder in ancient Egypt (Lucas and Harris 1962:1–2). Egg white appears to have been used in varnishes on paintings in the medieval period, a practice that continued into the twentieth century (Stringari 1990; Peres 1990; Woudhuysen-Keller and Woudhuysen-Keller 1994); the practice may also have been carried out on painted wood artifacts. Documentary sources suggest that egg white probably served as a temporary varnish; ordinarily, as much of it as possible would have been removed before a final varnish was applied. The fourteenth-century *De Arte Illuminandi* mentions a combination of egg white and plant gum or cane sugar in varnish (Thompson and Hamilton 1993:22).

**Chemical composition.** Egg white is a viscous material that consists of about 10–12% solids suspended in water. The solids are about 90% protein, of which there are several types. Egg white also contains a small amount of sugars (about 4%)—some bound to proteins (glycoproteins)—and salts (about 4%). The stringy property of egg white is due to one of the minor proteins (ovomucin). To make a useful binding medium, the white is beaten. The froth formed by beating is discarded, while the remaining solution, no longer viscous, can be further thinned and mixed with pigments. The binder contains many of the original components of the egg white, of which the major one is the protein ovalbumin. Egg white dries by evaporation of water to form a weak, brittle film.

Aged egg white can be highly insoluble. This suggests that changes in some of the proteins during drying and aging are not reversible; however, under controlled laboratory conditions, egg white can be resolubilized after complete drying.

**Analysis.** Because of the similarity of the amino acid profiles for egg white and yolk, a further test for lipids (as discussed in the section on egg yolk that follows) would be prudent in order to eliminate the possibility that yolk is present. The most conclusive evidence for egg white comes from identification of specific biological marker compounds unique to egg white. Ovalbumin, which makes up nearly 60% of the white's protein, can be

identified in paint cross sections by reaction with its antibody (Kockaert, Gausset, and Dubi-Rucquoy 1989). The overall reliability of this type of test is not yet certain.

It is also possible to use microscopic examination to identify avidin, a very minor component of egg white. Avidin, a glycoprotein, makes up about 0.05% of solid egg white (Wolbers 1988). The procedure can be applied on cross sections, but again, its reliability needs to be more thoroughly studied.

### Egg yolk

The principal documented use of egg yolk as a paint medium is in Italian medieval and Early Renaissance paintings. This technique was described by Cennino Cennini (1954) and has been thoroughly discussed in a recent exhibition catalogue (Bomford et al. 1989:26–29). The use of the medium may date back to a considerably earlier time, but firm analytical identifications in earlier paintings are rare. One Egyptian mummy portrait from the Roman period was determined to have been painted in an egg medium (Ramer 1979), either yolk (as indicated by its lipid content) or whole egg. While *tempera* is a general term for water-based paint media, it most often refers to paint bound with egg yolk (egg tempera). There are indications that during the later medieval period in Europe, egg-oil emulsions were sometimes used on panel paintings (Kockaert, Gausset, and Dubi-Rucquoy 1989; Kockaert 1984). Such mixtures have also been identified on later paintings (Plesters 1987; Mills 1987).

**Chemical composition.** The solids of egg yolk, which make up a little over half the fresh yolk by weight, consist of about one-third protein and two-thirds lipids. Very small amounts of natural colorants produce its characteristic yellow color. As with egg white, the yolk contains numerous proteins, some of which contain chemically bound phosphorus. Some also contain chemically bound carbohydrate. By definition, lipids are a broad group of heterogeneous natural products that are soluble in organic solvents but not in water. The lipids in egg yolk seem mostly to be intimately associated with some of the protein(s), perhaps buried within the approximately globular form of the proteins in their native states.

The lipid content of yolk can be divided into two major categories, phospholipids (about one-third) and triglycerides (about two-thirds). For a discussion on the structures of triglycerides—the compounds that make up natural oils—see the chapter by Erhardt on drying-oil media in this volume. The fatty acids in the triglycerides (oil) of fresh yolk consist of about one-third saturated acids and two-thirds unsaturated acids. Oleic acid accounts for about 60% of the unsaturated fatty acid, and linoleic about 25%, giving egg yolk oil a partially “drying” nature. The saturated fatty acids are mainly stearic and palmitic, in a ratio of about 2:1.

Like triglycerides, phospholipids consist of a backbone of glycerol, which is bonded to three other molecules, one of which is a phosphate. The major phospholipid in yolk is lecithin, a natural emulsifier that allows intimate mixing of the water-soluble components (proteins) and the water-insoluble components (triglycerides) of the yolk. The other major component of egg yolk is cholesterol, which makes up around 3.5% of the dry weight of the yolk.

In order to be used as a binder, egg yolk is simply diluted with water and mixed with pigments. An egg yolk film initially dries by evaporation of water. As water evaporates, the protein complexes become irre-

versibly denatured. The oil component undergoes similar reactions to those of drying oils in oil-paint films, eventually becoming somewhat polymerized. The lipid components, since they are only partially drying in nature, undoubtedly contribute some flexibility to egg yolk, which the other strictly protein-based binders do not have once they dry. Therefore, egg yolk films do not exhibit the typical stress patterns shown by films of water-soluble media that dry simply by water evaporation, such as gums, egg white, and glues (Keck 1969).

**Analysis.** The oil component provides one means of distinguishing yolk from other protein binders. The fatty acids of dried yolk films can be analyzed in the same manner as the fatty acids of drying-oil films, whether by microchemical testing or instrumental analysis. One current standard instrumental technique is GC. An aged egg yolk film contains substantial amounts of palmitic and stearic acids, and typically only a small amount of azelaic acid, a by-product of the drying process. For some years, the National Gallery in London, which pioneered the application of GC to analysis of binding media, has used analysis of the lipid component for identification of egg yolk.

An example of the possibilities of instrumental analysis and the difficulties in interpretation is the original tinted coating on an eighteenth-century commode in the Museum of Fine Arts, Boston (Newman 1994). Amino acid analysis by HPLC gave a profile similar to that of egg, while analysis of a separate scraping by gas chromatography–mass spectrometry (GC-MS) indicated the presence of drying oil with a small amount of pine resin. Cross sections showed the presence of a single red paint layer, which stained rather evenly for oil. From examination of cross sections and the instrumental analyses, it seemed most likely that the original tinted finish contained both egg and drying oil.

Infrared spectrometry of egg yolk paint films detects the lipid and protein components of the media simultaneously. If it is assumed that the lipid could not have come from another source (such as drying oil), the combination of protein and oil implies egg yolk as a binder. Py-GC also can be used to identify the presence of lipid and protein components in the same mixture (Chiavari et al. 1993).

One unique component of egg yolk not found in other common binders is cholesterol. Cholesterol is not highly stable, and to date it has not been proved that it can be easily identified in aged egg yolk paint films (Mills and White 1982); in fact, the compound may have undergone chemical alteration in many old paints. The specific pigments present in an egg yolk film can also have a major influence on the stability of cholesterol.

**Degradation.** Medieval paintings carried out with egg yolk often remain in good condition, indicating that the medium is among the most stable of the natural binders. The oil component, however, undergoes the same types of autoxidation and polymerization as drying oils. Ultimately, these produce a mixture of low-molecular-weight polymers or breakdown products that may be susceptible to leaching by various solvents. Polymerized proteins are one possible by-product of such reactions, as are brownish condensation products (Horie 1992). There have been no published studies that focus on the degradation of egg yolk films over time, although one recent publication points to the complex nature of the medium's behavior (Khandekar, Phenix, and Sharp 1994). As mentioned in association with egg white, pigments that are acidic in nature may cause partial hydrolysis of the proteins in the binder and form inorganic salts

with liberated amino acids or fragments of the proteins. Infrared studies of old paint samples suggest that this occurs.

### Casein

The early history of casein in paints is sketchy. Ancient Hebrew documents reportedly mention its use (Gettens and Stout 1966:8). Cennini's *The Craftsman's Handbook* (1954:68) mentions the use of casein glue but does not mention casein paints. Lime casein was reported to have been the medium of some late-twelfth-century wooden panels from the ceiling of a church (Denninger 1969). Casein paints, which were produced in the United States on a commercial scale beginning in the late nineteenth century, were apparently very popular in interior and exterior house painting throughout the nineteenth century, probably popularized by a late-eighteenth-century French book that appeared in translation just after 1800 (Phillips 1994:253). How extensively casein paints were used, and what the specific formulations were, can be understood only by analysis of paint samples. Virtually no detailed examinations of these paints have been published to date.

**Chemical composition.** By definition, casein refers to a group of several proteins that are found in milk. Casein proteins are usually divided into four major fractions, but each fraction may contain more than one specific protein. With reference to paint, the term *casein* usually indicates any paint with a binder derived from milk, although such binders may contain significant amounts of compounds (lipids and/or carbohydrates) other than the casein proteins themselves (Phillips 1994).

The solids of milk, which make up about 13% by weight of the natural material, are complex in composition. About 24% is made up of proteins, 31% of lipids (fats), 38% of lactose (milk sugar), and the remainder (7%) mainly of various ions. About 80% of the protein is casein. In raw milk, the several individual casein proteins combine to form roughly globular micelles suspended in water. The casein proteins contain phosphorus (about 1% by weight overall). One of the casein proteins also contains some carbohydrate as part of its structure. Most of the carbohydrate content of raw milk, however, is in the form of lactose, a disaccharide (formed from the simple sugars galactose and glucose). The lipids in raw milk are present in the form of triglycerides, the same type of compounds found in drying oils. A typical distribution of the fatty acids in cow milk fat is around two-thirds saturated fatty acids and one-third unsaturated. The major saturated fatty acids are palmitic, stearic, and myristic, in a ratio of approximately 2:1:0.8. Oleic makes up most of the unsaturated fatty acid. Because of the low unsaturated fatty acid content, this oil is essentially nondrying in nature.

Casein paint can be quite variable in composition and properties, depending on how it is prepared. Whatever the formulation, casein paint films are brittle, porous, and matte. The simplest "casein paint" would simply involve mixing milk with pigments. If whole milk were used, the dried paint would contain all of the components of the original milk. Drying simply involves evaporation of water. As the water evaporates, the protein micelles become denatured. This is an irreversible change, meaning the protein micelles are no longer soluble in water after drying. However, the milk sugar component remains readily soluble in water; thus, such a milk paint would probably be easily damaged by water.

A purer casein paint could be produced by beginning with curds, which are precipitated from soured milk and are rich in casein (the casein micelles become unstable under acidic conditions). Washed, dried, and ground curds are largely insoluble in water but can be solubilized by the addition of a base. Drying of such a casein paint involves evaporation of water; if a volatile base (such as ammonia) has been used, the protein will precipitate as the water and the base evaporate. If a nonvolatile base is used (such as lime), the cation of the base (calcium, in the case of lime) reacts with the protein molecules during drying to form highly insoluble calcium-protein complexes; reaction occurs at the phosphate groups on the protein. Depending on formulation, a casein paint could remain readily soluble in alkaline water or could be virtually insoluble after drying. If skim milk were used for the curds, the resulting paint would contain little if any of the original oil or fat component but could still contain some milk sugar. For example, a canvas painting by William Morris Hunt recently analyzed at the Museum of Fine Arts in Boston was done in casein paint (Newman 1991). Analyses showed that the fat content was minimal, but appreciable lactose was present in the paint, which was sensitive to water.

**Analysis.** Analysis for phosphorus has been an additional test used to distinguish caseins from other protein binders (Stulik and Florsheim 1992; Martin 1977). The phosphorus content of the casein proteins is much higher than that of the proteins in the other common protein-rich binders; thus, a positive result for protein and phosphorus in a paint sample suggests casein, but it would not be positive proof. Analyses for sugar content could be useful since many older caseins may contain milk sugar. Identification of equal amounts of glucose and galactose, the two simple sugars that make up lactose, would be very suggestive. Since the solubility properties of casein paints can vary considerably, sensitivity to water is not a very useful criterion in itself.

**Degradation.** While the other common protein-containing binders show little compositional variation from one sample to another, caseins can show a quite considerable variation depending on method of preparation. For this reason, degradative reactions could vary considerably from one casein to another. For example, reactions between the sugar and protein components, as well as between the lipid and protein components (discussed earlier with reference to other proteins), would be potentially more important in less purified caseins.

---

## Carbohydrate-Containing Media

The only common carbohydrate-containing binding media are plant gums. Other carbohydrates much more rarely used as binders include honey and starch.

### Chemical composition of carbohydrates

Carbohydrates consist of monosaccharides (simple sugars) or compounds that can be broken down into monosaccharides by hydrolysis. Monosaccharides are small molecules that occur in many living organisms (Fig. 6). Polymers that are formed from two monosaccharide molecules are disaccharides; common examples are lactose (milk sugar) and sucrose (cane or beet sugar). Polysaccharides are polymers formed from hundreds or



Figure 6a–f

Structures of some monosaccharides (a–e) and a uronic acid (f) found in carbohydrate-containing media. In solution, these compounds exist in several forms; those shown here are one of the two most common for each material (the  $\alpha$  forms).

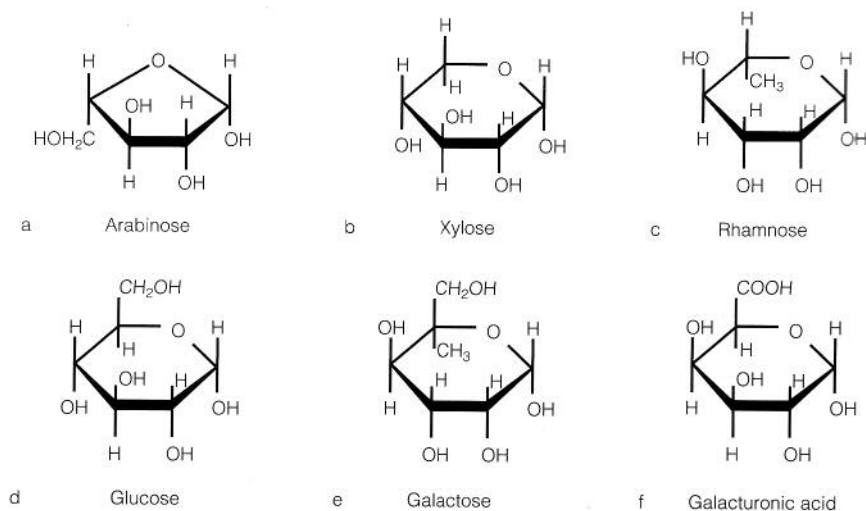

even thousands of monosaccharide molecules. Some have a linear structure (each sugar bonded at each end to another sugar molecule); cellulose (the structural material of plants) is an example of this type of polysaccharide. Cellulose is formed from only one type of monosaccharide (glucose). Starch—chiefly found in plant seeds, roots, bulbs, and tubers—consists of two different carbohydrates. One of these (amylose) is a linear carbohydrate similar to cellulose but much smaller in size; it is water soluble. The other carbohydrate in starch (amylopectin) has a highly branched structure, in which many sugar molecules are bonded to more than two other sugar molecules; this fraction is not water soluble. As with cellulose, the only monosaccharide in both of the carbohydrate fractions of starch is glucose.

Many plants produce polysaccharides known as gums, in which the simple sugars are bonded together to form large, branched molecules that are soluble (or dispersible) in water. Gums typically are formed from more than one type of monosaccharide.

### Plant gums

The major applications of gum-bound paints have been in manuscript illuminations and watercolor paintings on paper. Plant gums were probably one of the major painting media in ancient Egypt (Newman and Halpine 1994); however, few identifications of gum binders on wooden artifacts have been published. Plant gum as a varnish or coating was found to be applied locally to gilding on some Gothic polychrome sculptures, including a 1466 altarpiece by Friedrich Herlin (Broekman-Bokstijn, van Asperen de Boer, and Serck-Dewaide 1970). The carbohydrate-containing medium may have been mixed with a protein and was probably applied to attenuate the brilliance of the leaf.

One of the most common of the gums is gum arabic, the most common source of which is the bushlike tree, *Acacia senegal*, which grows in central and northern Africa, extending east to the Sind region of India. The gum molecules are made up of well over one thousand individual sugar units (Anderson, Hirst, and Stoddart 1966). As with most polymers, molecules of gum arabic display a range of molecular weights. Another gum that has been used in artifacts is gum tragacanth, an exudate from various species of *Astragalus* (Twilley 1984). This gum, which is only partially solu-

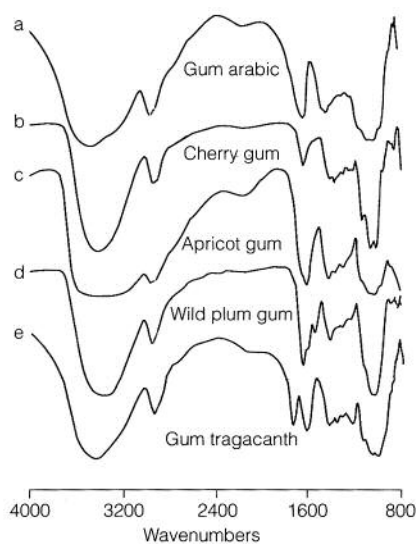

Figure 7  
Infrared transmittance spectra of some plant gums. Note that the spectra are quite similar, with the exception of gum tragacanth.

ble in cold water, consists of at least two rather different polysaccharides (Aspinall and Baillie 1963). Other gums—including fruit-tree gums such as apricot, peach, and cherry—have been identified in artifacts (Birstein 1975). Other types of *Acacia* gums besides *Acacia senegal* may have been utilized in artifacts. One has been suggested as a binding medium for the wall paintings in Nefertari's tomb in Egypt (Stulik, Porta, and Palet 1993).

**Chemical composition.** Plant gums consist almost entirely of polysaccharides. They also contain small amounts of amino acids (Anderson, Hendrie, and Munro 1972). Specific gums contain two or more different monosaccharides, the identity and relative amounts of which often vary from one plant source to another. In addition, gums usually contain one or two different types of uronic acids, which are compounds derived from monosaccharides (for example, the one shown in Fig. 6f).

Plant gums are simple to collect; tears of solidified gum can be broken off branches of the plant or allowed to collect around a cut. Gum-bound paints dry by evaporation of water without any significant change in the shape or composition of the molecules. They tend to be brittle and remain sensitive to water but can become less soluble with age (Daniels and Shashoua 1993).

**Analysis.** The common microchemical tests detect simple (reducing) sugars (Stulik and Florsheim 1992; Feigl 1960:426), which are easily liberated from gums by hydrolysis; many carbohydrate-containing binders would respond positively to these tests. In ultraviolet light, plant gums fluoresce bright bluish white. In some instances it may be possible to detect gum in paint cross sections or chips of paint under an ultraviolet fluorescence microscope by using a reagent that chemically alters sugars, destroying the fluorescence (Wolbers 1990:30–33). Infrared spectra of different plant gums show some variations, but usually this technique is useful only for general identification (Fig. 7). More specific information is obtainable through the use of Py-GC, which can distinguish some gums from others in paint samples (Derrick and Stulik 1990).

Specific attempts at identification usually involve breaking down the gum into its constituent monosaccharides and uronic acids, and then separating these. To date, most analyses of this type have been carried out by TLC or GC. Some sample preparation and analytical procedures (typically TLC) can characterize both the neutral monosaccharides and uronic acids, and this would be desirable if the identification of a specific gum type is required (Masschelein-Kleiner 1986). Other sample preparation methods (typically those used for GC) readily characterize only the neutral monosaccharides (Twilley 1984; Erhardt et al. 1988); but this information, too, can be useful, since types and relative amounts of such sugars often vary from one type of gum (or other carbohydrate-containing material) to another, as shown in Figure 8. The red paint on a Ptolemaic period Egyptian canopic container (Fig. 9) was determined to have a gum binder on the basis of GC analysis of its simple sugar content (Fig. 10a). The gum was clearly not *Acacia senegal* (gum arabic), a chromatogram of which is also shown (Fig. 10b), but it could have been another species of *Acacia*.

Since plant gums contain small amounts of amino acids (usually less than 1% by weight), it is also possible to partially characterize them on the basis of analysis of their amino acid profiles. The amino acid profiles of plant products such as gums are quite distinct from the amino acid profiles of the common protein-containing paint binders (Anderson, Hendrie, and Munro 1972) discussed previously.

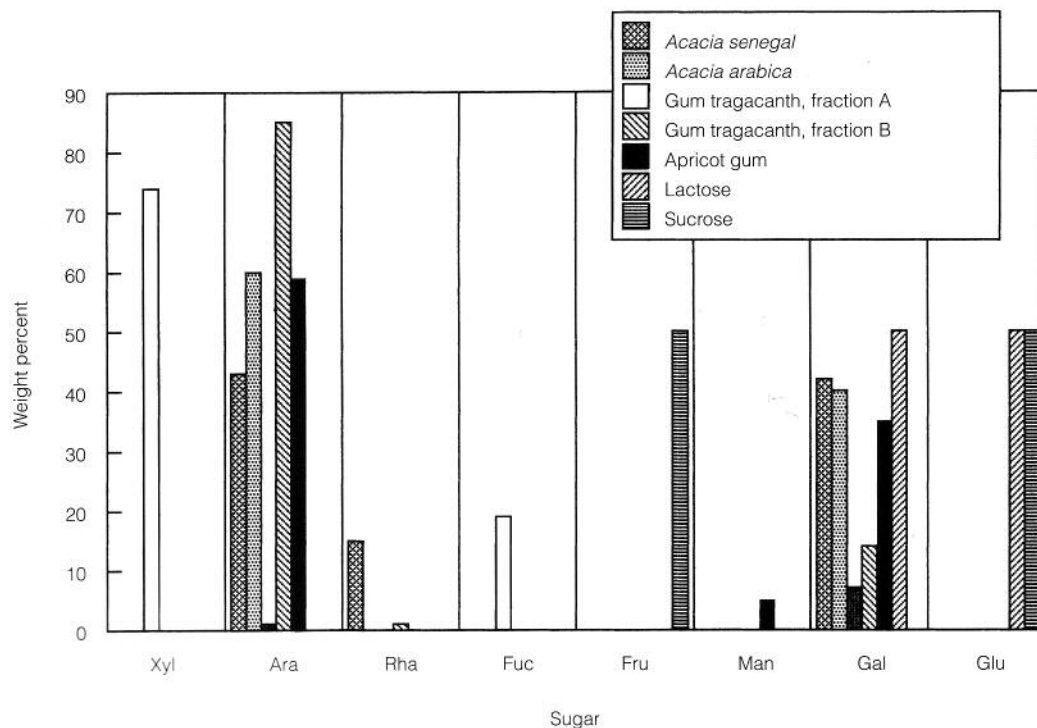

Figure 8

Monosaccharides in some gums and other carbohydrate-containing materials. The first two materials are varieties of gum arabic. Gum tragacanth contains two water-soluble fractions (A and B), which differ in composition. Lactose (milk sugar) is found in unpurified caseins. Sucrose (table sugar) is a major component of honey. Xyl, xylose; Ara, arabinose; Rha, rhamnose; Fuc, fucose; Fru, fructose; Man, mannose; Gal, galactose; Glu, glucose. (Sources of data: *Acacia* gums: Anderson and Karamalla 1966; gum tragacanth: Aspinall and Baillie 1963:1704; Twilley 1984:381).

**Degradation.** Little is known about the degradation of plant gums over long periods of time. Some portions of gum molecules are readily hydrolyzable under acidic conditions, so it is likely that gum-containing paints that have been buried or stored in a humid environment may have broken down to some extent. As with other natural polymers, limited hydrolysis greatly reduces the size of the molecules and probably weakens the paint without any chemical changes in the constituent monosaccharides. While it is not clear whether chemical changes figure prominently in the aging of gum-bound paints, oxidation and other reactions that occur during the aging of cellulose and other complex carbohydrates found in wood and paper (Hon 1981) may also take place in gums.

#### Other Carbohydrates

Honey has been identified as a binder in a single ancient Egyptian paint sample (Masschelein-Kleiner, Heylen, and Tricot-Marckx 1968). In more recent times, starch or dextrin (produced by partial hydrolysis of starch) might be encountered. Starch was utilized in East Asian painting from an early period, although usually as an adhesive rather than a paint binder (Winter 1984). Dextrin is an ingredient in many modern commercial artists' watercolor paints. Plant juices, which contain simple sugars, were sometimes used in manuscript illuminations, according to documentary sources (Thompson 1956:61).

The analytical procedures already described can be applied to identification of these other carbohydrate-based binders. In addition, there is a specific microchemical test for starch that can be used (Stulik and Florsheim 1992).



Figure 9  
Painted wood canopic chest, Egypt, Ptolemaic period (332–331 B.C.E.). Museum of Fine Arts, Boston (accession no. 98.1128).

Figure 10a, b  
Chromatograms (a) of a sample of red paint from the canopic chest shown in Figure 9; and (b) of *Acacia senegal* (gum arabic). Analyses carried out by gas chromatography–mass spectrometry. The paint and gum samples were hydrolyzed, and monosaccharides were analyzed as trimethylsilyl oxime derivatives (each sugar gives rise to two major peaks). Note that the paint sample differs from gum arabic in that it contains virtually no rhamnose; the paint binder also has a greater arabinose : galactose ratio than gum arabic.

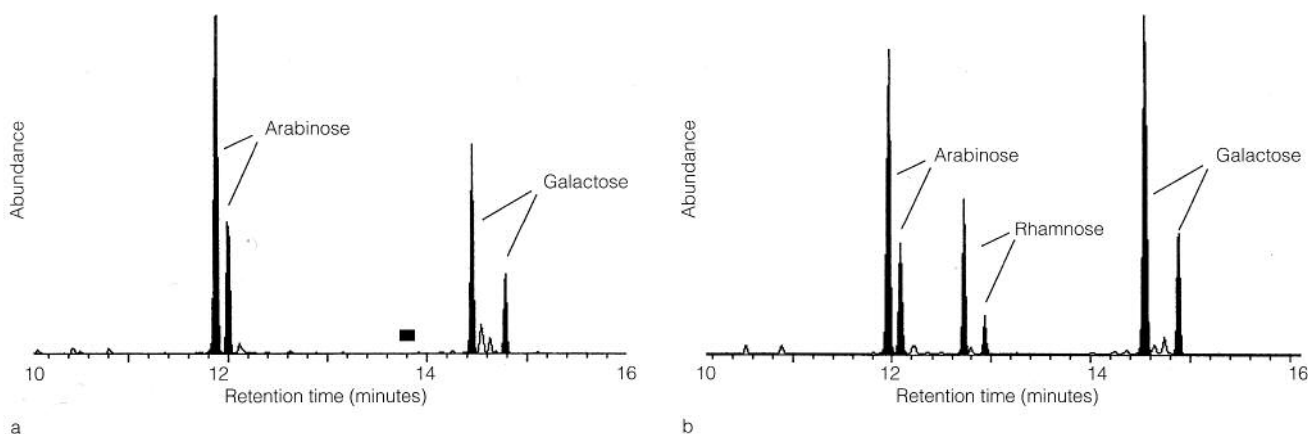

many kinds of trees and plants. Probably the earliest uses of natural resins on wooden artifacts were as varnishes, coatings, and adhesives. In ancient Egypt, for example, resin varnishes were used on some artifacts beginning in the Middle Kingdom (Lucas and Harris 1962). These varnishes, which appear to have been applied in very viscous forms, could have been simply the natural solvent-containing resins extracted from their source trees. Medieval European varnishes were probably solutions of one or more resins in drying oils (Barry 1932:2–8); residues of such varnishes have been identified on medieval Italian egg tempera paintings (Dunkerton, Kirby, and White 1990). Resin solutions in solvents (spirit varnishes) were probably not common until after the medieval period. Particularly in the context of furniture, varnishes may have been made from mixtures of several different natural resins. A popular eighteenth-century European treatise, for example, described over a dozen individual resins for use in furniture varnishes (Mussey 1982). The preparation of a varnish depends on the resin or resins involved in the recipe. Some resins are quite readily soluble, while some of the less soluble resins were often heated or “run” as part of the preparation, a process that can cause partial decomposition.

Small amounts of natural resin may have been incorporated in some oil paints from the earliest periods from which oil paintings are known. A particularly common example is copper resinate glazes, fairly transparent solutions of the pigment verdigris in resin and oil. Such solutions have been found in panel paintings and were also used in early English and American architectural (house) paints (Welsh 1994). Resin-rich oil paint media have been popular in certain periods and places, some of the best known being *megilp* and *gumtion* of nineteenth-century England and America. Both contained linseed oil and mastic resin (Carlyle 1990).

Natural resins can occur in other contexts on wooden artifacts. For example, brocades on some medieval European polychromed sculptures were underlaid by mixtures of wax and natural resin(s). Tinted glazes, probably bound by natural resins, were also used on metal leaf—for example, to make tin leaf appear to be gold.

In contrast to the plant resins, the use of shellac on painted wooden artifacts is mostly restricted to varnishes and coatings. The secretion from the lac insect was also the source of a red colorant (commonly known as *lac*), first mentioned about 250 C.E. (Barry 1932:237). The use of the secretion in varnish is first mentioned in an Indian text of 1590, and around the same time the resin apparently became known in Europe.

Shellac was a component of some European varnish recipes by the seventeenth century (Bristow 1994). The resin was also used to seal knots and absorbent wood surfaces before painting.

### Chemical composition of plant resins

When freshly collected, plant resins contain varying amounts of natural solvents, up to about 30% by weight in some cases. Most resins are marketed in the form of the solid material left behind after evaporation of the volatile constituents. The solubilities of resins vary considerably: some are completely soluble in several organic solvents (alcohols, turpentine, methylene chloride, etc.), others only partially soluble. As with solubility, the melting ranges of resins vary considerably, from slightly under 100 °C to around 300 °C. Thin, dried films of the soluble natural resins are brittle; they remain soluble in organic solvents, although in most cases their solubility changes substantially with aging as a result of chemical reactions.

Most plant resins contain many different compounds, most of which fall into two general chemical categories: diterpenoids and triterpenoids. These two classes of material never occur together in a single resin. Examples of resins that contain diterpenoids are pine, larch (commonly known as Venice turpentine), sandarac, copals (of which there are many varieties), and copaiba balsams. Triterpenoid resins include mastic, damar, and elemi. The chemical compositions of the natural resins are discussed in detail in several publications (Mills and White 1977; Mills and White 1987). The structures of a few specific compounds found in plant resins are shown in Figure 11. Plant resins that contain substantial amounts of involatile compounds other than diterpenoids and triterpenoids include benzoin, myrrh, and frankincense (olibanum). Some resins are collected from the ground, rather than taken from living trees, and may be a few thousand years of age (for example, kauri copal). Amber is a true fossil resin of much greater age.

Unlike the resins just mentioned, shellac is of insect origin and has a composition quite different from those of the plant resins. It is made from the secretion of an insect, with shellac making up about 80% of the secretion (Barry 1932:248). Shellac appears to consist of small polymers of sesquiterpene acids (which contain 15 carbons) and hydroxycarboxylic acid.

### Analysis of plant resins

The best approaches to detection and identification of natural resins depend on the nature of the sample, of which there are two categories: (1) a varnish or slightly tinted coating in which natural resin is the only major component; and (2) a paint film, consisting of pigments and binders, of which resin is one component but typically not the major one.

In a varnish, even relatively thin layers of natural resin can be detected in cross sections by their milky green fluorescence, utilizing ultraviolet fluorescence microscopes; shellac can usually be distinguished by its orange-tinted fluorescence. A reactive reagent (antimony pentachloride in chloroform) has been used as a further confirmation for plant resins in varnish layers in cross sections (Wolbers and Landrey 1987). Analysis of thin cross sections by infrared (IR) microspectrometry can provide more specific information, even permitting some identifications of specific resins (Derrick et al. 1992). This technique can be particularly useful in the case of objects such as furniture, which may have multiple coating layers of

Figure 11

Structures of some diterpenoids (top six compounds) and triterpenoids (bottom two compounds) found in plant resins. Abietic acid is an important constituent of pine resins and some other conifer resins, and is also found in kauri copal. Dehydroabietic acid is a major constituent of aged pine and conifer resins. Sandaracopimaric acid, a component of pine and other conifer resins, is also a major component of sandarac resin. Larixol is a component of Venice turpentine and is not found in any other major resin. Agathic acid is found in a number of copal resins, eperuic acid in a number of African copal resins. Dammaradienol is found in damar resins, masticadienonic acid in mastic resins.

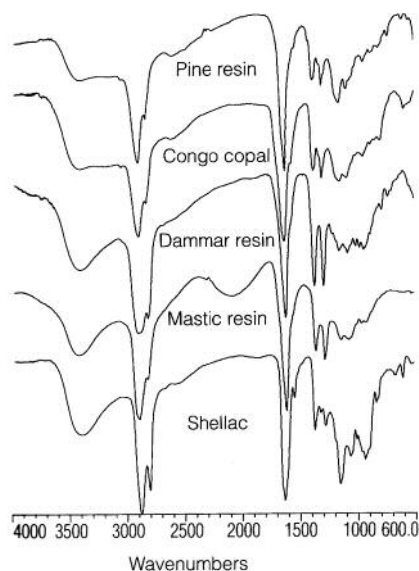
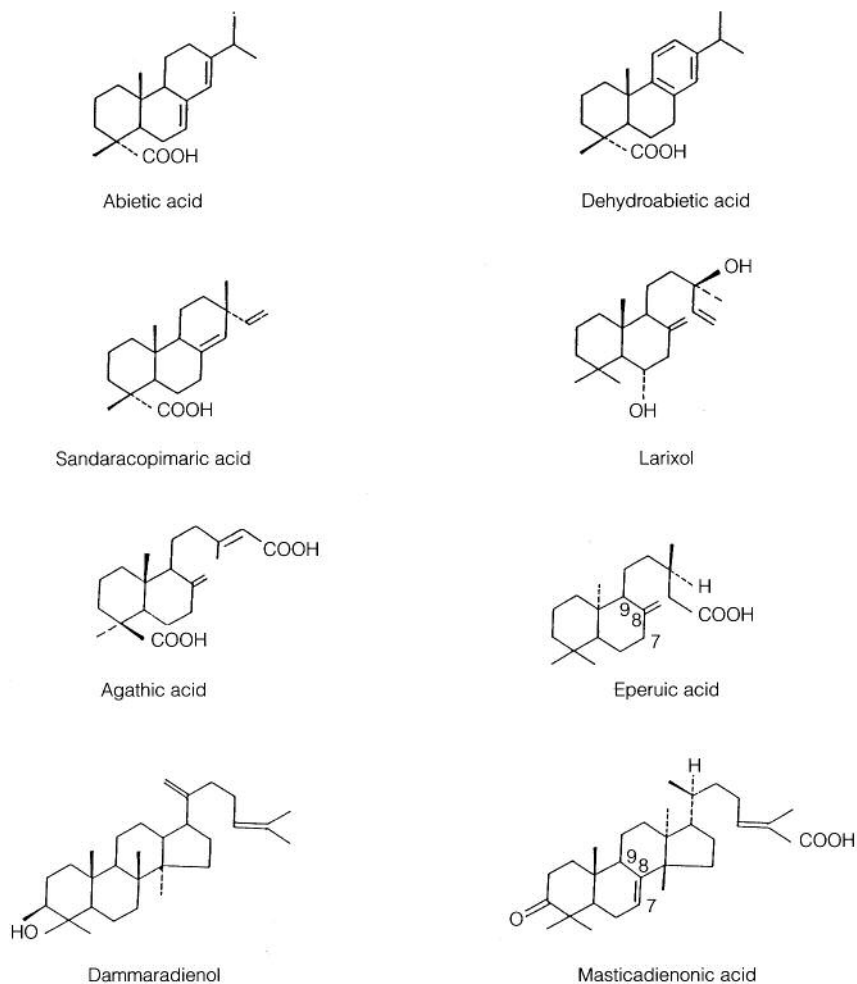

Figure 12

Infrared transmittance spectra of some resins. While all these spectra of fresh, unaged resins are generally similar, there are distinctive differences that permit specific identifications, particularly in the region below about 1800 wave numbers. Aged resins are more difficult to identify.

differing compositions. Small amounts of resins in paint films (for example, oil-resin binders) generally cannot be detected in cross sections by any currently utilized technique, including IR microspectrometry.

With bulk samples that consist mainly (or entirely) of resin, most of the instrumental techniques listed in Table 1 (see appendix in this article) have been applied. Infrared spectrometry of varnishes can in some cases provide specific identifications and possibly even identify the individual components of mixtures (Derrick 1989), although the latter is probably an area where the technique would not be highly useful. Figure 12 shows representative IR spectra of a number of resins. Py-GC can distinguish individual resins from one another (Shedrinsky, Wampler, and Baer 1988); its application to samples containing several different resins, as could occur in old varnishes, has not been studied in any detail.

Of the current techniques, gas chromatography is the most useful for specific identifications of individual resins and mixtures of resins (Mills and White 1987:149–52; Koller and Baumer 1993). Because of the complexity of resins, GC-MS is more definitive than GC alone. GC-MS can also be successfully applied to identification of small amounts of resins in paint films (for example, Mills and White 1982; White and Kirby 1994). Aged resins are often very different in composition from fresh samples of the same resins, but enough work has been published on numerous natural resins that characteristic compounds detectable in older samples are

known. An example of GC-MS analysis of a complex paint sample is shown in Figure 13. While not all of the compounds detected in the sample could be identified, the presence of linseed oil, pine resin, mastic resin, and probably an African variety of copal resin was confirmed.

### Degradation of plant resins

Many of the compounds in natural resins are relatively unstable. Loss of solubility and increasing yellowness with aging are two well-known problems with natural resin films. While the rate of degradation varies from one resin to another, most undergo oxidation and photochemical reactions of various types (e.g., see De la Rie 1988). The nature and extent of degradation depends on environmental conditions (e.g., access of light and oxygen to the resin) and the type of resin. For example, Bronze Age samples of mastic resin excavated from shipwrecks contain many of the characteristic compounds of freshly tapped mastic (Hairfield and Hairfield 1990), whereas excavated samples of pine resin from the same period consist almost exclusively of oxidation products not present in fresh pine resins (Beck, Smart, and Ossenkop 1989). Changes in the solubility of resins with aging may be partly due to some polymerization in certain instances. Heating during preparation of a resin can alter the chemistry of some resins; undoubtedly, changes occur during the “running” process that was

Figure 13a, b

Chromatogram of green paint sample from *Beach Scene at Concorneau* (n.d.), a painting by Robert Henri (1865–1929). The sample was saponified, extracted, and methylated for GC-MS analysis. Top (a): full chromatogram, showing that the major peaks are due to azelaic, palmitic, and stearic acids. These show that the major component of the sample is drying oil, probably linseed. Bottom (b): detail of the later part of the chromatogram, showing a number of smaller peaks. Small amounts of some fatty acids (labeled A20 and A22) and some hydrocarbons (labeled H24 and H26) were detected, probably trace components of the oil. Two compounds characteristic of aged pine resins have been detected: P1, dehydroabietic acid; P2, 7-oxodehydroabietic acid. Four other peaks are characteristic of copal resins: C1, eperuic acid; C2, probably communic acid; C4, agathic acid. C3 is a compound whose identification has not been determined, but it is found in some Congo copals. While the specific type of copal cannot be identified, it is probably an African variety since eperuic acid seems to be restricted to these copals. Later in the chromatogram (retention times from 27 to 32 minutes), some triterpenoid compounds were detected that match those of reference mastic resins.

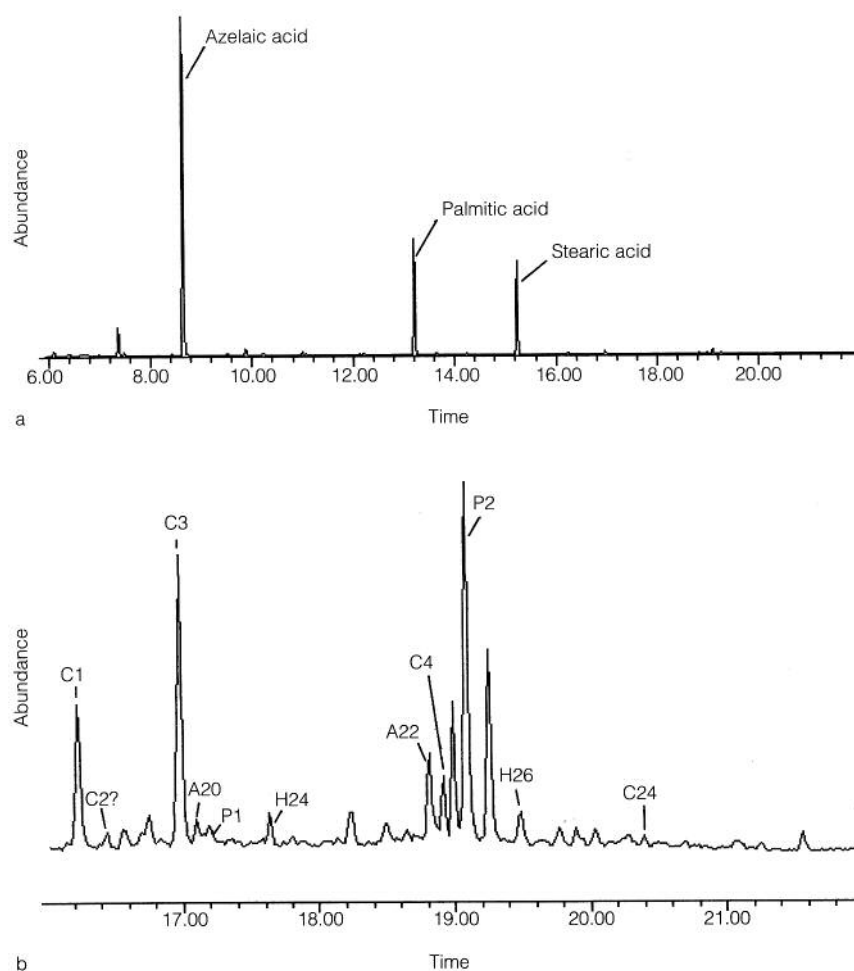

used to put some of the harder resins into solution during the manufacture of varnishes, although the nature of these changes has not been studied to any great extent.

Resins can undergo reactions with other media and with certain pigments. Many contain substantial amounts of acidic compounds, which can form salts with some pigments. It is likely that chemical reactions occur between natural resins and drying oils in oil-resin varnishes or paints that contain both types of materials.

---

## Waxes

Waxes are a loosely defined group of materials of plant, animal, and mineral origin. While rather diverse in composition, they are all translucent solids with low melting points and a “waxy” feel. Beeswax, from beehives, is probably the first natural wax to have been utilized in painting. It was reportedly used as a binding medium in ancient Egypt, although there are very few reliable identifications of use before Roman times (Lucas and Harris 1962:352–53). It has been identified on some wall paintings, but most likely it served as a varnish or coating rather than as a paint medium. Documentary sources indicate that wax painting was a popular technique in Greek and Roman times. The earliest surviving wax paintings are the well-known Fayum portraits (so-called mummy portraits) found in tombs in the al-Fayyūm region of ancient Egypt. The binding medium in these paintings may actually be Punic wax. Pliny the Elder described the preparation of Punic wax (Kühn 1960), which involved heating beeswax in alkaline salt water three times, a procedure that would have led to partial saponification. Because the alkali contained nonvolatile metallic ions (sodium, potassium, or calcium), the final product contained salts of the fatty acids liberated by saponification. The Fayum portraits seem to have been executed with melted wax, applied with metal implements or with brushes.

One other common use of beeswax was in pastes associated with appliqué relief brocades on European medieval polychromed objects (Serck-Dewaide 1990). Several identifications have been reported, usually of wax mixed with natural resin(s), perhaps also with oil or honey. Beeswax has been a common polishing or coating material on furniture.

There are many natural waxes of plant origin, including carnauba (from the carnauba, or fan palm—*Copernicia cerifera*—which mostly grows in Brazil) and esparto (from esparto grass, of Spanish and Algerian origin). A recent analysis indicated the use of esparto wax as the binding medium in paints applied on planks from a Phoenician ship of about 400 B.C.E. (Glastrup 1995).

### Chemical composition of waxes

Straight-chain saturated hydrocarbons with the general formula  $\text{CH}_3 - (\text{CH}_2)_n - \text{CH}_3$  are found in a number of waxes. Ozokerite—found associated with some lignite coal beds—and ceresin—refined from ozokerite—consist almost entirely of hydrocarbons; typically, these contain between about 20 and 32 carbon atoms, with the most abundant hydrocarbons falling in the range between about 23 and 29 (Mills and White 1987). Hydrocarbons make up about 14% of beeswax by weight; they contain only odd numbers of carbon atoms in the range 25–35, with the most abundant being the 27-carbon compound. Esparto and other waxes also contain hydrocarbons (Tulloch 1973).



Other important components of many waxes include fatty acids, long-chain alcohols, or esters derived from the acids and alcohols. Beeswax, in addition to hydrocarbons (14%), contains about 12% by weight free fatty acids (the major one contains 24 carbons) and 65% esters (Tulloch 1972). The majority of these esters are monoesters; that is, esters formed from a fatty acid and an alcohol that has one alcohol functional group (monoalcohol). The most abundant fatty acid found in these esters is palmitic acid. Mills and White (1987) review the compositions of waxes and include references to analytical studies.

Because of its heterogeneous composition, beeswax melts within a temperature range of about 60–65 °C. Reaction with alkali (saponification) breaks down the beeswax esters, liberating fatty acids and alcohols. A partially saponified beeswax (of which Punic wax may have been an example) melts within a range extending somewhat higher than that of pure beeswax. Extensive enough saponification can result in a material that may be emulsified in water. As a binder, pure beeswax can be used in two basic ways: either as a solution in an appropriate organic solvent (such as turpentine) or melted. If sufficiently saponified, the wax could be used as an emulsion in water. Most other waxes could also be applied by melting or in solutions.

### Analysis of waxes

Since wax-bound paint samples usually soften and melt at much lower temperatures than paints in the other common media, melting point measurements have often been applied to establish the presence of wax in paint samples. Many waxes are fairly readily soluble in weak organic solvents such as petroleum benzine, another property that can be useful in tentatively identifying waxes, as virtually no other common medium is substantially affected by such solvents. Infrared spectrometry has been widely utilized for identifying beeswax and other waxes, although specific identification is not always possible (Kühn 1960); to aid in an IR identification, the medium can be extracted with a solvent to eliminate most of the interference from pigments. Some representative IR spectra are shown in Figure 14. Although

*Figure 14*  
Infrared transmittance spectra of some waxes. Ceresin wax consists entirely of hydrocarbons. The characteristic pairs of sharp peaks due to these compounds are indicated by the letter H; hydrocarbons are also found in the other three waxes shown. Candelilla (from a species of plant that grows in the southern United States and Mexico), beeswax, and carnauba (from a type of palm that grows mostly in Brazil) contain esters (characteristic peaks marked E). Carnauba also contains other types of compounds. The IR spectrum of a wax can sometimes provide specific identification, while in other cases it may only narrow down the possibilities.

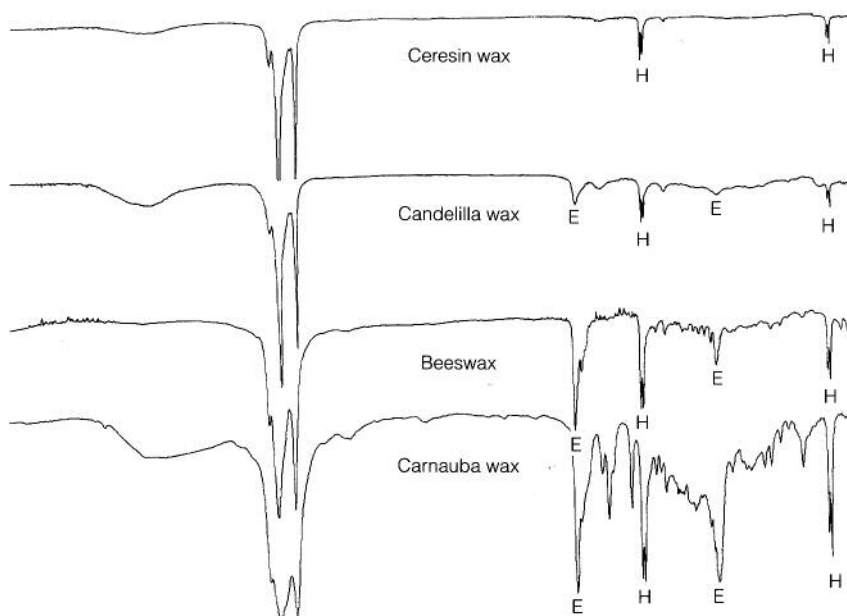

not widely used for identification purposes, thin-layer chromatography has recently been shown to be useful (Striegel and Hill 1997).

Specific identification of waxes can be carried out by gas chromatography. It is possible to directly analyze solutions of waxes (White 1978). All of the hydrocarbons found in waxes are readily identified by GC. The monoesters in beeswax and other waxes are also sufficiently volatile for direct GC analysis, although the higher-molecular-weight esters and some other compounds in many waxes are not. Another common approach to analyzing ester-containing waxes involves saponifying the sample, which liberates fatty acids from the esters (Mills and White 1987:146–47). GC analysis of a saponified sample of beeswax, for example, shows the hydrocarbons (which are not affected by the chemical treatment), the free fatty acids of the original wax (also not affected by saponification), and the fatty acids derived from the esters. Altogether these compounds make up only a small fraction of beeswax, but their pattern is sufficiently distinctive to permit positive identification of the wax. An example is shown in Figure 15, which compares a chromatogram from

Figure 15a, b

Chromatograms (a) of a reference beeswax sample; and (b) of a paint sample from an Egyptian Fayum portrait (Museum of Fine Arts, Boston). Both samples were saponified and methylated for GC-MS analysis.

Hydrocarbons are labeled H, followed by the number of carbon atoms; fatty acids are labeled A, followed by the number of carbon atoms (for example, A16, palmitic acid; A18:1, oleic acid; A18, stearic acid). The patterns of even-numbered fatty acids and odd-numbered hydrocarbons characteristic of beeswax can be seen in the Fayum portrait sample, although in the portrait the overall level of hydrocarbons is distinctly lower.

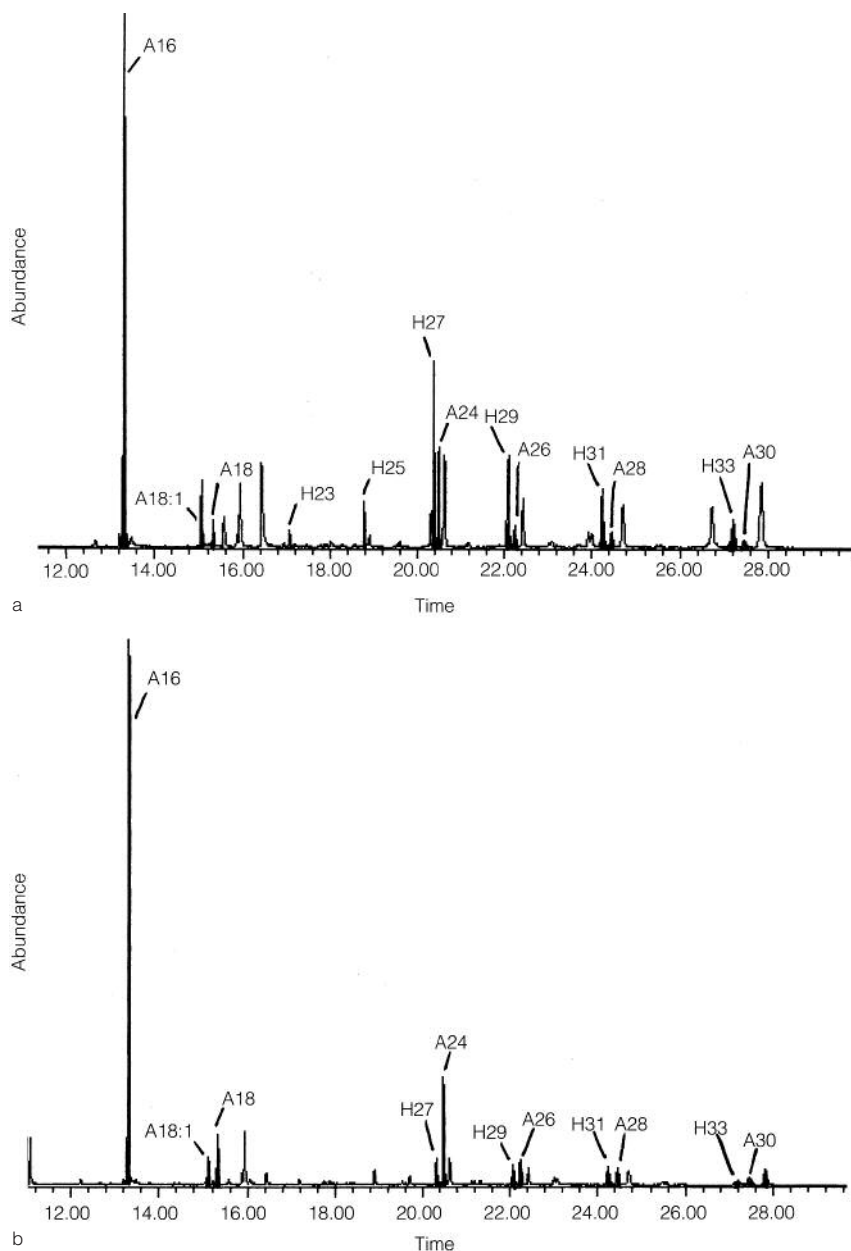

a Fayum portrait paint sample and a beeswax standard. Direct analysis of a solution of a beeswax-containing paint sample by GC could probably distinguish a partially saponified wax on the basis of the profile of esters and free fatty acids, but this has not been systematically investigated.

Wax can be an additive to other types of paints, such as oil paints. Small quantities of admixed wax can usually be readily detected by GC, but it would be difficult to detect by any other of the commonly used identification procedures.

### Degradation of waxes

The hydrocarbon components of beeswax and other waxes are chemically very stable. Like other esters, the esters in beeswax can be broken down by saponification. Beeswax contains virtually no unsaturated fatty acids; thus, little oxidative degradation would be expected. A two-thousand-year-old sample from a Fayum portrait showed virtually no azelaic acid, confirming that oxidative degradation of the fatty acids in the esters had not taken place. Interaction with certain pigments may occur, resulting in the formation of fatty acid soaps, which are salts of inorganic ions. These interactions would be virtually the same as those that could occur in oil-paint films.

---

## Appendix

### Identification of Binding Media in Paint Samples

While documentary sources provide crucial information on media used by particular cultures or artists, expansion of current knowledge is dependent on analysis of paint from artifacts. A basic understanding of media identification is important because the use of appropriate techniques is critical to the technical study of painted artifacts. Table 1 summarizes the most widely used current techniques. While many procedures can be applied to identification of any particular medium, each procedure has unique capabilities and limitations. The following comments provide an overview.

#### General considerations

In approaching medium analysis, a first consideration is desired *specificity* of identification. Some methods determine the general chemical class of binders (for example, protein) but cannot distinguish between specific varieties within that class (glue, egg, casein, etc.); others can provide more specific information. A second consideration is *scale* of analysis, which depends on both the amount of paint sample available and the structure of the sample. Some analytical procedures require larger samples than others. If only a very small sample were available, it would not be worthwhile to apply certain techniques because the amount of binder could well be below the levels detectable by the technique. The structure of the paint sample also must be considered. For a single paint layer, a scraping of paint could be used for the analysis; any results could be reasonably concluded to indicate the nature of binder in that layer. However, where multilayer paint structures are found, different binders could have been used in various parts of the structure. In such cases, it would be best to apply a technique that would work directly on a cross section of the paint structure, unless individual layers can be mechanically isolated for separate analysis.

Some analytical procedures are more universal in nature than others. A truly universal procedure, of which there are few, would simultane-

Table 1 Common analytical procedures for binding media identification

Procedure	Sample type	Proteins	Carbohydrates	Plant resins and shellac	Waxes	Drying oils
Microchemistry	B	G	G	G?		G
Infrared (IR) spectrometry	B	G	G	G, S?	G, S?	G
Pyrolysis-gas chromatography (Py-GC)	B	S?	S	S		S
Thin-layer chromatography (TLC)	B	S	S		S	
Gas chromatography (GC) and GC-mass spectrometry (GC-MS)	B	S	S	S	S	S
High-performance liquid chromatography (HPLC)	B	S				
Visible-light staining of cross sections	CS	G, S?				G
Fluorescent staining of cross sections	CS	G, S?	G?	G?		G
Infrared (IR) microspectrometry of thin cross sections	CS	G		G, S?		G

B = bulk sample (scraping, chip, etc.)

CS = cross section

G = procedure that is usually used only to identify the general class of material indicated in the column heading

G? = procedure that can sometimes determine the presence of the general class of material, but not always

S? = procedure that can sometimes determine specific varieties within the general class

S = procedure that can often determine specific varieties within the general class

ously identify many different types of binders during a single analysis. Since most tests or analyses will not simultaneously detect all the types of compounds found in organic binders, a full characterization typically requires more than one procedure or one series of analyses. Confirmation of the presence of some materials and lack of detection of others provides a more certain identification than simple confirmation of one material, and ultimately the identification will be more useful for future researchers if a systematic series of tests is carried out.

### Current analytical procedures

The conservation literature on media identification is quite extensive. Masschelein-Kleiner (1986) provides a useful summary of the major literature on analytical procedures up to 1986. A systematic series of microchemical procedures was recently described by Stulik and Florsheim (1992). Microchemical tests are the most affordable approach but require somewhat larger samples than might be available from many artifacts. Thin-layer chromatography, a comparatively inexpensive specific analysis procedure, has recently been reviewed (Striegel and Hill 1997). Erhardt and coworkers (1988) very briefly described a systematic instrumental analytical procedure that encompasses nearly all of the instrumental techniques currently widely utilized for binder identification. Microchemical tests and the major instrumental procedures all require scrapings (bulk samples) and cannot be utilized directly on cross sections.

Infrared spectrometry is a universal instrumental technique. Pigments, however, frequently interfere with results, and for the most part the technique is useful for general rather than specific identification in paint samples. Fourier-transform infrared (FT-IR) microscope systems, which are becoming increasingly common, can provide information on extremely small samples (Derrick, Landry, and Stulik 1991), generally

much smaller than those that can be analyzed by the other common instrumental techniques.

Another universal instrumental approach couples pyrolysis, a sample preparation technique, with gas chromatography (Py-GC). Pyrolysis involves heating a paint sample to a high temperature, causing the organic binder to break down into smaller volatile fragments. The pyrolytic products are then separated in a gas chromatograph. Pigments do not seem to interfere with the results, and, to some extent, specific media identifications can be carried out by this technique. Shedrinsky and coworkers (1989) recently reviewed applications of pyrolysis–gas chromatography to art and archaeological materials.

Plant gums and proteinaceous media are natural polymers that can be chemically broken down into their fundamental building blocks (monomers). In the case of gums, the monomers are monosaccharides and acids derived from some of these monosaccharides (uronic acids); in the case of proteins, the monomers are amino acids. Separation of these monomers along with at least some quantitation of the different types of monomers can provide very specific information on binder type. Analysis is usually carried out by a chromatography technique: these range from thin-layer chromatography, already mentioned, to the more expensive instrumental procedures, such as gas chromatography, high-performance liquid chromatography (HPLC), and tandem techniques such as gas chromatography–mass spectrometry. Chromatography procedures are not universal but can provide the most specific identifications of any of the routinely applied binder identification techniques.

Aged drying-oil films are also polymeric in nature (see Erhardt, herein). Unlike the gums and proteins, dried oil films cannot be broken down into their original monomeric units, but they can be at least partially broken down into smaller fragments that are useful for identification purposes. GC and GC-MS are the standard techniques for the analysis of these fragments. This type of analysis is the only current method by which specific identifications of different types of drying oils is possible.

Gas chromatography and, better yet, GC-MS are also the current techniques of choice for specific identification of plant resins, which typically consist of mixtures of a number of different compounds. In many instances, these compounds differ enough from one resin to another to allow for separation and specific identification of resin types.

The most widely utilized procedure for identification of binders in cross sections is biological staining. Applications, for the most part, focus on determination of the presence of proteins and lipids (drying or other oils, fats, etc.), although some specific identification is possible. Some stains can be viewed under visible light (Johnson and Packard 1971; Martin 1977); others need to be viewed with a microscope that has an epifluorescence attachment (Wolbers and Landrey 1987). Stains can also be applied in certain cases for the confirmation of the presence of other materials, such as carbohydrates and resins.

Fourier-transform infrared microspectrometry, already mentioned as a technique that can be applied to scrapings of paint (or bulk samples), can also be applied on cross sections (Derrick, Landry, and Stulik 1991). The least ambiguous results, using both staining and infrared analysis, are obtained on thin sections, which are sliced from cross sections with a microtome.

### Cautions on identifications

Modern analytical techniques in some cases are so sensitive that it is now possible to identify small amounts of organic residues in samples taken from artifacts. This makes possible a wealth of information that was not previously obtainable, but it also may open the door to misinterpretation. Of particular concern in the study of samples from artifacts are previous restorations or treatments. Consolidation of paint or repeated cleanings and applications of varnishes can introduce many types of organic materials into paint films while potentially removing some of the original organic components or accelerating their deterioration. Obviously, if added components are of an altogether different chemical nature than the original components, careful analysis could distinguish original material from these additions. However, many materials used, particularly in past decades, were of natural origin and include many of the materials discussed in this chapter. Treatment with a gelatin solution of an artifact painted with glue-bound paints would make analysis of the original binder impossible—even with current instrumental analytical procedures—because an old glue cannot be distinguished from a glue of recent origin. Treatment of a polychromed wooden object with wax would preclude any possibility of identifying wax as an original component of the binding medium, unless the wax were of a modern type with a different chemical structure than the type or types that would have been available when the object was painted.

Codes of ethics of modern art conservation usually state that any organic material introduced onto an old painted surface should be of an altogether different composition than that of the original organic components, so as not to make future analysis problematic. However, even some widely utilized modern synthetic materials could potentially cause problems. For example, cellulose ethers are currently used to consolidate fragile paint. Hydrolysis of such a material would yield glucose. While it is not a component of plant gums, glucose can occur in some carbohydrate-containing binders, and the introduction of this carbohydrate by a treatment would make the original presence of glucose impossible to ascertain. Many such scenarios could be given; the important point is that results of analyses must be interpreted with caution.

The ideal approach would be to characterize the original materials as completely as possible before treatment. It is also advised that one take into account the binders most likely to be present in the paint film when choosing a consolidation material and adhesives for a given treatment.

---

## References

- Aitken, M. J.  
1990 *Science-Based Dating in Archaeology*. London: Longman.
- Anderson, D. M. W., A. Hendrie, and A. C. Munro  
1972 The amino acid and amino sugar composition of some plant gums. *Phytochemistry* 11:733–36.
- Anderson, D. M. W., E. Hirst, and J. F. Stoddart  
1966 Studies on uronic acid materials, part 17: Some structural features of *Acacia senegal* gum (gum arabic). *Journal of the Chemical Society (C)*:1959–66.

- Anderson, D. M. W., and K. Karamalla  
1966 Studies on uronic acid materials, part 12: The composition of *Acacia* gum exudates. *Journal of the Chemical Society (C)*:762–64.
- Aspinall, G. O., and J. Baillie  
1963 Gum tragacanth, part 2: The arabinogalactan. *Journal of the Chemical Society*:1714–21.
- Barry, T. H.  
1932 *Natural Varnish Resins*. London: Ernest Benn.
- Beck, C., C. Smart, and D. Ossenkop  
1989 Residues and linings in ancient Mediterranean transport amphoras. In *Archaeological Chemistry*, vol. 4, ed. R. O. Allen, 369–80. Washington, D.C.: American Chemical Society.
- Birstein, V. J.  
1975 On the technology of Central Asian wall paintings: The problem of binding media. *Studies in Conservation* 20:8–19.
- Bomford, D., J. Dunkerton, D. Gordon, and A. Roy  
1989 *Art in the Making: Italian Painting before 1400*. London: National Gallery.
- Bristow, I. C.  
1994 House painting in Britain: Sources for American paints, 1615 to 1830. In *Paint in America*, ed. R. W. Moss, 42–53. Washington, D.C.: Preservation Press.
- Broekman-Bokstijn, M., J. R. J. van Asperen de Boer, and M. Serck-Dewaide  
1970 The scientific examination of the polychromed sculpture in the Herlin altarpiece. *Studies in Conservation* 15:370–99.
- Brommelle, N. S., and P. Smith, eds.  
1988 *Urushi: Proceedings of the Urushi Study Group, June 10–27, 1985, Tokyo*. Marina del Rey, Calif.: Getty Conservation Institute.
- Carlyle, L.  
1990 British nineteenth-century oil painting instruction books: A survey of their recommendations for vehicles, varnishes, and methods of paint application. In *Cleaning, Retouching and Coatings: Technology and Practice for Easel Paintings and Polychrome Sculpture*, ed. J. S. Mills and P. Smith, 76–80. London: International Institute for the Conservation of Historic and Artistic Works (IIC).
- Cennini, Cennino d'Andrea  
1954 *The Craftsman's Handbook: The Italian "Il libro dell'arte."* Trans. D. V. Thompson. New York: Dover.
- Chiavari, G., G. C. Galletti, G. Lantera, and R. Mazzeo  
1993 The potential of pyrolysis–gas chromatography/mass spectrometry in the recognition of ancient painting media. *Journal of Analytical and Applied Pyrolysis* 24:227–42.
- Collings, T. J., and F. J. Young  
1976 Improvements in some tests and techniques in photographic conservation. *Studies in Conservation* 21:79–84.
- Coomaraswamy, A. K.  
1934 The technique and theory of Indian painting. *Technical Studies in the Field of Fine Arts* 3:58–89.
- Daniels, V. D., and Y. R. Shashoua  
1993 The effect of gum arabic solubility on the washing of watercolours. In *ICOM Committee for Conservation Preprints, 10th Triennial Meeting, Washington, D.C.*, 442–46. Paris: International Council of Museums (ICOM) Committee for Conservation.

- De la Rie, E. R.  
1988 Photochemical and thermal degradation of films of dammar resin. *Studies in Conservation* 33:53–70.
- Denninger, E.  
1969 The examination of pigments and media from the painted wooden ceiling of St. Michael's Church at Hildesheim, Germany. *Studies in Conservation* 14:91–95.
- Derrick, M. R.  
1989 Fourier transform infrared spectral analysis of natural resins used in furniture varnishes. *Journal of the American Institute for Conservation* 28:43–56.
- Derrick, M. R., J. M. Landry, and D. C. Stulik  
1991 *Methods in Scientific Examination of Works of Art: Infrared Microspectroscopy*. Marina del Rey, Calif.: Getty Conservation Institute.
- Derrick, M. R., and D. C. Stulik  
1990 Identification of natural gums in works of art using pyrolysis–gas chromatography. In *ICOM Committee for Conservation Preprints, 9th Triennial Meeting, Dresden, 9–14*. Paris: ICOM Committee for Conservation.
- Derrick, M. R., D. C. Stulik, J. M. Landry, and S. P. Bouffard  
1992 Furniture finish layer identification by infrared linear mapping microspectroscopy. *Journal of the American Institute for Conservation* 31:225–36.
- Dunkerton, J., J. Kirby, and R. White  
1990 Varnish and early Italian tempera paintings. In *Cleaning, Retouching and Coatings: Technology and Practice for Easel Paintings and Polychrome Sculpture*, ed. J. S. Mills and P. Smith, 63–69. London: IIC.
- Erhardt, D., W. Hopwood, M. Baker, and D. von Endt  
1988 A systematic approach to the instrumental analysis of natural finishes and binding media. In *AIC Preprints, 16th Annual Meeting, American Institute for Conservation, New Orleans, Louisiana, 67–84*. Washington, D.C.: American Institute for Conservation of Historic and Artistic Works (AIC).
- Feigl, F.  
1960 *Spot Tests in Organic Analysis*. Trans. R. E. Oesper. Amsterdam: Elsevier.
- Gettens, R. J., and G. L. Stout  
1966 *Painting Materials: A Short Encyclopaedia*. 1942. Reprint, New York: Dover.
- Glastrup, J.  
1995 A note on the analysis of the binding medium from a Phoenician shipwreck. *Studies in Conservation* 40:65–68.
- Hairfield, H., and E. Hairfield  
1990 Identification of a late Bronze Age resin. *Analytical Chemistry* 62:41A–45A.
- Halpine, S. M.  
1991 Internal report, 27 June, National Gallery of Art Scientific Department, Washington, D.C.
- 1992a Amino acid analysis of proteinaceous media from Cosimo Tura's *The Annunciation with Saint Francis and Saint Louis of Toulouse*. *Studies in Conservation* 37:22–38.
- 1992b Internal report, 5 March, National Gallery of Art Scientific Department, Washington, D.C.



- 1995 An investigation of artists' materials using amino acid analysis: Introduction of the one-hour extraction method. *Conservation Research 1995*, Studies in the History of Art 51, Monograph Series 2. Washington, D.C.: National Gallery of Art.
- Hansen, E. F., S. Walston, and M. Hearn's Bishop, eds.**
- 1994 *Matte Paint: Its history and technology, analysis, properties, and conservation treatment with special emphasis on ethnographic objects*. Marina del Rey, Calif.: Getty Conservation Institute.
- Hon, D. N.-S.**
- 1981 Yellowing of modern papers. In *Preservation of Paper and Textiles of Historic and Artistic Value*, vol. 2, ed. J. C. Williams, 119–42. Washington, D.C.: American Chemical Society.
- Horie, C. V.**
- 1992 Preservation of natural macromolecules. In *Polymers in Conservation*, ed. N. S. Allen, M. Edge, and C. V. Horie, 32–46. London: Royal Society of Chemistry.
- Johnson, M., and E. Packard**
- 1971 Methods used for the identification of binding media in Italian paintings of the 15th and 16th centuries. *Studies in Conservation* 16:145–64.
- Karpowicz, A.**
- 1981 Ageing and deterioration of proteinaceous media. *Studies in Conservation* 26:153–60.
- Keck, S.**
- 1969 Mechanical alteration of the paint film. *Studies in Conservation* 14:9–30.
- Khandekar, N., A. Phenix, and J. Sharp**
- 1994 Pilot study into the effects of solvents on artificially aged egg tempera paint films. *The Conservator* 18:62–72.
- Kockaert, L.**
- 1973–74 Note sur les emulsions des primitifs flamands. *Bulletin de l'Institut Royale du Patrimoine Artistique* 14:133–39.
- 1984 Note on the painting technique of Melchior Broederlam. In *ICOM Committee for Conservation 7th Triennial Meeting, Copenhagen, 10–14 September 1984 Preprints*, 84.19.7–10. Paris: ICOM Committee for Conservation.
- Kockaert, L., P. Gausset, and M. Dubi-Rucquoy**
- 1989 Detection of ovalbumin in paint media by immunofluorescence. *Studies in Conservation* 34:183–88.
- Koller, J., and U. Baumer**
- 1993 The scientific analysis of traditional Western coatings: Systematic approach and case studies. In *Preprints of the 17th International Symposium on the Conservation and Restoration of Cultural Property*, 178–92. Tokyo: Tokyo National Research Institute of Cultural Properties.
- Kühn, H.**
- 1960 Detection and identification of waxes, including Punic wax, by infra-red spectrography. *Studies in Conservation* 5:71–81.
- Lollar, R. M.**
- 1984 Skin and hide. In *Protein Chemistry for Conservators*, ed. C. L. Rose and D. W. Von Endt, 25–30. Washington, D.C.: AIC.
- Lucas, A., and J. R. Harris**
- 1962 *Ancient Egyptian Materials*. London: Edward Arnold.

- Martin, E.  
1977 Some improvements in techniques of analysis of paint media. *Studies in Conservation* 22:63–67.
- Masschelein-Kleiner, L.  
1986 Analysis of paint media, varnishes, and adhesives. *PACT* 13:185–208.
- Masschelein-Kleiner, L., J. Heylen, and F. Tricot-Marckx  
1968 Contribution à l'analyse des liants, adhésifs et vernis anciens. *Studies in Conservation* 13:105–21.
- Mills, J.  
1987 The paint medium [of Samuel van Hoogstraten's *Peepshow*]. *National Gallery Technical Bulletin* 11:85.
- Mills, J. S., and R. White  
1977 Natural resins of art and archaeology: Their sources, chemistry and identification. *Studies in Conservation* 22:12–31.
- 1982 Organic mass-spectrometry of art materials: Work in progress. *National Gallery Technical Bulletin* 6:3–18.
- 1987 *The Organic Chemistry of Museum Objects*. London: Butterworths.
- Mussey, R.  
1982 Early varnishes: The eighteenth century's search for the perfect film finish. *Fine Woodworking* 35:54–57.
- Newman, R.  
1991 Examination report on *Niagara* (1888; accession no. 67.14) and *Gloucester Harbor* (1887; accession no. 44.47) by William Morris Hunt. Report, Boston, Museum of Fine Arts.
- 1994 Examination report on a French-Canadian commode (accession number 1994.83) in the Museum of Fine Arts, Boston. Report, Boston, Museum of Fine Arts.
- Newman, R., and S. Halpine  
1994 The binding media of ancient Egyptian painting. In *Colour and Painting in Ancient Egypt*. London: British Museum.
- Peres, C. M.  
1990 Vincent van Gogh's triptych of trees in blossom, Arles (1888), part 2: Examination and treatment of the altered surface coatings. In *Cleaning, Retouching and Coatings: Technology and Practice for Easel Paintings and Polychrome Sculpture*, ed. J. S. Mills and P. Smith, 131–33. London: IIC.
- Phillips, M. W.  
1994 A survey of paint technology: The composition and properties of paints. In *Paint in America*, ed. R. W. Moss, 231–55. Washington, D.C.: Preservation Press.
- Plesters, J.  
1987 The materials and technique of the *Peepshow* in relation to Hoogstraten's book. *National Gallery Technical Bulletin* 11:82.
- Ramer, B.  
1979 The technology, examination, and conservation of the Fayum portraits in the Petrie Museum. *Studies in Conservation* 24:1–13.
- Roy, A.  
1988 The technique of a *Tüchlein* by Quinten Massys. *National Gallery Technical Bulletin* 12:36–43.

- Schilling, M. R., and H. P. Khanjian  
1996 Effects of pigments and accelerated aging on the identification of proteinaceous binding media. Gas chromatographic analysis of amino acids as ethyl chloroformate derivatives, pt. 2. *Journal of the American Institute for Conservation* 35:123–44.
- Schilling, M. R., H. P. Khanjian, and L. A. C. Souza  
1996 Composition of proteins associated with art objects and monuments. Gas chromatographic analysis of amino acids as ethyl chloroformate derivatives, pt. 1. *Journal of the American Institute for Conservation* 35:45–60.
- Serck-Dewaide, M.  
1990 Relief decoration in sculptures and paintings from the thirteenth to the sixteenth century: Technology and treatment. In *Cleaning, Retouching and Coatings: Technology and Practice for Easel Paintings and Polychrome Sculpture*, ed. J. S. Mills and P. Smith, 36–40. London: IIC.
- Shedrinsky, A., T. Wampler, and N. S. Baer  
1988 The identification of dammar, mastic, sandarac, and copal by pyrolysis gas chromatography. *Weiner Berichte über Naturwissenschaft in der Kunst* 4–5:12–25.
- Shedrinsky, A. M., T. P. Wampler, N. Indictor, and N. S. Baer  
1989 Application of analytical pyrolysis to problems in art and archaeology: A review. *Journal of Analytical and Applied Pyrolysis* 15:393–412.
- Sinkai, T., I. Nagasawa, T. Shida, and R. Sugisita  
1992 Analysis of binding media and adhesives in Buddhist wooden sculptures. *Scientific Papers on Japanese Antiques and Art Crafts* 37:1–11.
- Skans, B., and P. Michelsen  
1986 Die Bedeutung von Fett in Tierleim für Malzwecke. *Maltechnik* 96:63–71.
- Stoner, J. H.  
1990 Art historical and technical evaluation of works by three nineteenth-century artists: Allston, Whistler, and Ryder. In *Appearance, Opinion, Change: Evaluating the Look of Paintings*, 36–41. London: United Kingdom Institute for Conservation.
- Striegel, M., and J. Hill  
1997 *Thin-Layer Chromatography for Binding Media Analysis*. Scientific Tools for Conservation. Los Angeles: Getty Conservation Institute.
- Stringari, C.  
1990 Vincent van Gogh's triptych of trees in blossom, Arles (1888), part 1: Examination and treatment of the altered surface coatings. In *Cleaning, Retouching and Coatings: Technology and Practice for Easel Paintings and Polychrome Sculpture*, ed. J. S. Mills and P. Smith, 126–30. London: IIC.
- Stulik, D., and H. Florsheim  
1992 Binding media identification in painted ethnographic objects. *Journal of the American Institute for Conservation* 31:275–88.
- Stulik, D., E. Porta, and A. Palet  
1993 Analyses of pigments, binding media, and varnishes. In *Art and Eternity: The Nefertari Wall Paintings Conservation Project, 1986–1992*, ed. M. A. Corzo and M. Afshar, 55–65. Marina del Rey, Calif.: Getty Conservation Institute.
- Thompson, D. V.  
1956 *The Materials and Techniques of Medieval Painting*. 1936. Reprint, New York: Dover.
- Thompson, D. V., and G. H. Hamilton, trans.  
1993 *An Anonymous 14th-Century Treatise, De Arte Illuminandi: The Technique of Manuscript Illumination*. New Haven, Conn.: Yale University Press.

- 1971 Traub, W., and K. Piez  
Chemistry and structure of collagen. *Advances in Protein Chemistry* 25:243–352.
- 1972 Tulloch, A. P.  
Analysis of whole beeswax by gas liquid chromatography. *Journal of the American Oil Chemists' Society* 49:609–10.
- 1973 Comparison of some commercial waxes by gas liquid chromatography. *Journal of the American Oil Chemists' Society* 50:367–71.
- 1984 Twilley, J.  
The analysis of exudate plant gums in their artistic applications: An interim report. In *Archaeological Chemistry*, vol. 3, ed. J. B. Lambert, 357–94. Washington, D.C.: American Chemical Society.
- 1984 Von Endt, D. W.  
Protein adhesives. In *Protein Chemistry for Conservators*, ed. C. L. Rose and D. W. Von Endt, 39–47. Washington, D.C.: AIC.
- 1994 Welsh, F. S.  
The Early American palette: Colonial paint colors revealed. In *Paint in America*, ed. R. W. Moss, 68–85. Washington, D.C.: Preservation Press.
- 1978 White, R.  
The application of gas chromatography to the identification of waxes. *Studies in Conservation* 23:57–68.
- 1994 White, R., and J. Kirby  
Rembrandt and his circle: Seventeenth-century Dutch paint media re-examined. *National Gallery Technical Bulletin* 15:64–78.
- 1984 Winter, J.  
Natural adhesives in East Asian paintings. In *Adhesives and Consolidants*, ed. N. S. Brommelle, E. M. Pye, P. Smith, and G. Thomson, 117–20. London: IIC.
- 1988 Wolbers, R.  
Aspects of the examination and cleaning of two portraits by Richard and William Jennys. In *AIC Preprints, 16th Annual Meeting, American Institute for Conservation, New Orleans, Louisiana*, 245–60. Washington, D.C.: AIC.
- 1990 *Notes for Workshop on New Methods in the Cleaning of Paintings*. Marina del Rey, Calif.: The Getty Conservation Institute.
- 1987 Wolbers, R., and G. Landrey  
The use of direct reactive fluorescent dyes for the characterization of binding media in cross-sectional examinations. In *AIC Preprints: 15th Annual Meeting, American Institute for Conservation, Vancouver, British Columbia*, 168–202. Washington, D.C.: AIC.
- 1994 Woudhuysen-Keller, R., and P. Woudhuysen-Keller  
The history of eggwhite varnishes. *Hamilton Kerr Institute Bulletin Number* 2:89–141.

# Microscopic Examination and Analysis of the Structure and Composition of Paint and Varnish Layers

James S. Martin

**P**AINT AND VARNISH often are applied individually or together to create decorative and protective coatings on wood surfaces. Paint consists of a film-forming component called a *binder* and one or more organic or inorganic colorants called *pigment*. Varnish is an organic protective coating that does not contain a colorant. Paint binders and varnishes are often composed of similar materials, such as drying oils, proteins, natural and synthetic resins, gums, or waxes. The composition and purity of paints and varnishes have varied through history as commerce, trade, and technology have provided artists and artisans with new materials. The composition of these materials, their manner of application, and the ways in which they have altered and degraded have a very practical bearing on the conservation, interpretation, and authentication of historic and artistic works of which they are a part.

Microscopy permits one to observe the structure of layers (stratigraphic analysis) and the solubility and melting point of specific layers. Microscopy also allows one to determine the elemental composition of microscopic samples (elemental analysis) and to identify the chemical groups formed by these elements (chemical analysis). Elemental and chemical analysis may involve microchemical reactions between a sample and a reagent (chemical microscopy) or use of an instrument to detect the absorption or emission of electromagnetic radiation by a sample (spectroscopy).

---

## Samples

Samples from painted and varnished wood may take different forms—flakes, particles, or scrapings. To facilitate discussion, samples used for microscopic analysis can be divided into two general categories: layered samples and particle samples (Fig. 1). Layered samples contain one or more complete layers, while particle samples contain only a portion of a particular layer. Layered samples are used to study the number, sequence, condition, and interaction of layers. Both layered and particle samples are used to study the solubility, melting point, or composition of specific layers.

Samples are taken with the expectation that the information derived from analysis will be representative of the area sampled, if not the object itself. This is a rather tall order for microscopic samples. Reedy and Reedy (1988:14–16) describe theoretical approaches to sampling that have a statistical bearing on the likelihood of obtaining samples that are representative. A review of documentary records, thorough surface examination,

Figure 1

Idealized schematic representation of a painted and varnished surface (A); B = a layered sample, C = thin-section samples, and D = particle samples.

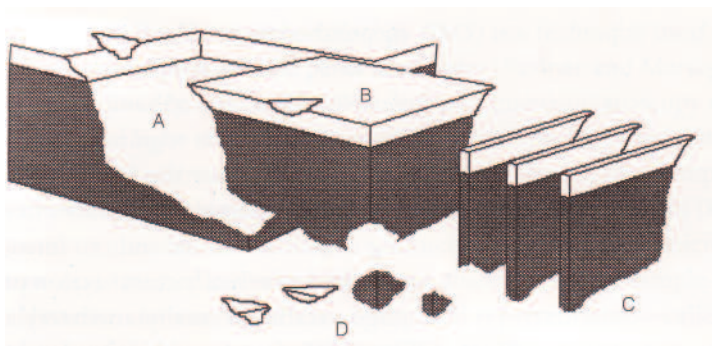

and a detailed sample record are helpful in obtaining representative samples, and in interpreting the results.

So-called surface examination techniques are used to determine the areal distribution of materials, and the characteristics that may help to narrow the initial investigation and confirm or support analytical results. Color, opacity, discoloration, fading, surface reflectance, texture, and layer continuity each reflect the ability of a paint or varnish to form and maintain a continuous film or to resist environment-induced alteration. Fluorescence under ultraviolet light is characteristic for a small number of pigments, including cadmium colors, Indian yellow, natural madder, and zinc white (De la Rie 1986). While visual inspection of binder and varnish fluorescence is not indicative of particular materials, surface fluorescence may reveal the distribution of paints, varnishes, restoration, and grime. Infrared vidicon systems (van Asperen de Boer 1986) and infrared photography (Hoeniger 1991) are commonly used to study infrared-absorbing underdrawing, and some researchers have reported success in differentiating between similarly colored paint films that are composed of different pigments. X-radiography (Van Schoute and Verougstraete-Marcq 1986) is used to study the composite structure of objects and the distribution of X-ray-absorbing materials, such as heavy metal pigments, metals, fabrics, and wood supports. X-ray fluorescence spectrometry (XRF) is an instrumental technique for noninvasive point analysis of elemental composition (Hanson 1970); however, instrumentation is very costly and the technique is not widely available.

The amount of sample required for microscopic analysis is very small. The literature commonly reports sizes in the range of 0.1–0.5 mm<sup>3</sup> for layered samples, while particle samples rarely exceed 0.1 mm<sup>3</sup> and frequently are much smaller. In practice, sample sizes are governed less by arbitrary measurement than by more practical constraints imposed by the object's size and condition, the location of sample sites, and whether samples might be returned following analysis. A variety of tools may be used to remove layered samples—for example, pointed scalpel blades, tungsten probes, forceps, and hypodermic needles. Particle samples, being much smaller, may be scraped from the surface of an exposed layer using a scalpel or probe, or collected as fragments from thin sections. Contamination and alteration may interfere with analysis or render samples unusable; therefore, they should be handled only with clean tools, stored in inert containers, and protected from extreme heat and light.

Sample preparation is an integral part of the analytical process and is tailored to the sample and the microscopic technique used. Particle samples are usually crushed and separated for analysis of component particles, and are often called *dispersed samples*. Layered samples are often cut

or polished to reveal a flat, planar cross section for examination and analysis; thus, layered samples are frequently called *cross sections* or *cross-section samples*. Most layered samples are so small or fragile that mounting in or to a solid matrix is required so they may be handled for sectioning and examination. Since the 1950s, layered samples typically have been prepared by placing a sample on a platform of hardened polyester resin and covering it with additional resin to form a solid block that is then ground and polished to reveal a cross-section plane (Plesters 1956); earlier techniques used paraffin or methyl methacrylate resin (Laurie 1914:18–24; Gettens 1940). The sectioned block is leveled on a piece of wax or clay and examined using reflected visible and epifluorescence illumination. Derrick and coworkers (1994) describe a wider range of embedding media used in conservation and in forensic and biomedical applications (polyester, epoxy, acrylics, cyanoacrylates, gelatin, wax, hot-melt adhesives, and silicones), and Pilc and White (1995) describe the use of silver chloride for embedding samples prior to thin-sectioning for infrared microscopy. Cross-section samples may be cut by microtome to yield numerous thin sections (Martin 1991; Gettens 1936; Tsang and Cunningham 1991; Malis and Steele 1990), or they may be polished on opposite sides to yield a single thin section (Garrido and Cabrera 1986). A thickness of 5–50  $\mu\text{m}$  is commonly reported for thin sections in the conservation literature. A nontraditional approach to the preparation and examination of layered samples is presented in the appendix to this chapter.

---

## Microscopic Techniques

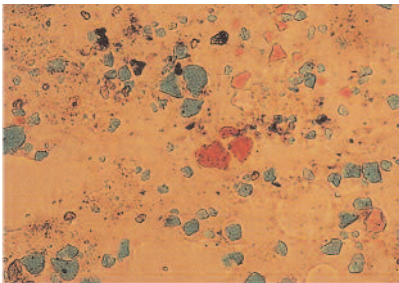

*Figure 2*  
Photomicrograph of a particle sample of paint dispersed in Cargille meltmount 1.662. The sample consists of viridian, red iron oxide, madder lake, yellow ochre, and lead white. The sample was photographed using transmitted plane-polarized illumination and a  $\times 40$  objective.

The human eye has an average resolving power of about 0.1 mm, and thus is incapable of distinguishing most paint and varnish layers, let alone individual pigment particles. Light (photon) microscopes and electron microscopes provide the magnification and resolution required to inspect and analyze samples.

Compound light microscopes are one of several light microscopes that form enlarged color images using glass or reflecting lenses and the near ultraviolet or visible regions of the electromagnetic spectrum. The maximum useful magnification obtained with compound light microscopes is about  $\times 1000$  with a resolution of approximately 0.2  $\mu\text{m}$  (0.0002 mm). Compound light microscopes can be equipped with a wide variety of reflected and transmitted illumination sources, objectives, and filters. These variations permit examination of individual layers and their component particles, determination of solubility and melting point, and analysis of optical properties and elemental and chemical composition. Compound light microscopes are used for two techniques that are fundamental to the microscopic analysis of paint and varnish: polarized light microscopy (PLM) and fluorescence microscopy (FM). Polarized light microscopy is used to characterize and identify particle samples (Fig. 2) and fiber samples, based on their absorption or refraction of polarized light (Slayter and Slayter 1992; McCrone and Delly 1978). Fluorescence microscopy is used to differentiate materials based on their primary fluorescence, or on the secondary fluorescence of fluorochromes used to mark them (Birk 1984). Other techniques use special optics to enhance contrast in samples (Hemsley 1989; Hoffman 1989) or use spectrophotometers to measure visible reflectance and fluorescence (Larson, Shin, and Zink 1991); these techniques are not used commonly in the art conservation field and will not be described in this chapter.

Infrared microspectroscopy (IMS) is a technique used for molecular analysis of layered and particle samples (Reffner and Martoglio 1995; Derrick, Landry, and Stulik 1991). Infrared microspectroscopy couples a compound light microscope with an infrared spectrometer. The compound light microscope is used to position a portion of a sample in an infrared beam that originates in a Fourier-transform infrared (FT-IR) spectrometer; hence, the technique is sometimes called FT-IR microspectroscopy. Infrared radiation that is not absorbed by the sample is passed to a detector and converted into a graphical representation—called a spectrum—of the sample's absorbance (Fig. 3). The spectrum may be used to determine the purity, degradation, and composition of the sample. When two or more materials are present in a sample—for example, pigments and a binder, or a varnish mixture—the spectrum represents data for all materials combined, complicating interpretation. Mixtures may be separated before analysis using chromatography or extraction, and spectra may be processed by computers to subtract the absorbance of one or more materials. Little or no sample preparation is required for infrared microspectroscopy, and the sample is neither consumed nor chemically altered in analysis; thus, it can be used for further analysis. Depending on opacity and layer thickness, samples may be analyzed in transmittance or reflectance modes. Transmittance spectroscopy is the method used most commonly for particle and thin-section samples. Transparent coatings on reflective surfaces, such as metal or metal leaf, might be analyzed using reflection/absorption spectroscopy. Opaque samples and surface layers may be analyzed using one of several reflectance techniques, including attenuated total internal reflection (ATR) (Harrick 1967).

Scanning electron microscopy (SEM) is a technique used for topographical examination and analysis of elemental surface composition (Slayter and Slayter 1992). The scanning electron microscope uses a beam of electrons and electromagnetic lenses to form enlarged, monochromatic images of specimens. The maximum useful magnification of these images is around  $\times 20,000$  with a resolution of about 10 nm (0.01  $\mu\text{m}$ )—a significant increase over compound light microscopes. So-called backscatter images are formed by electrons that are reflected, or backscattered, from the sample surface. Secondary electron images are formed by electrons

Figure 3

Infrared absorbance spectrum of the organic pigment indigo. The frequency (X axis) and intensity (Y axis) of absorption peaks are characteristic of the molecular structure of the material and are used to study changes in composition, purity, and degradation.

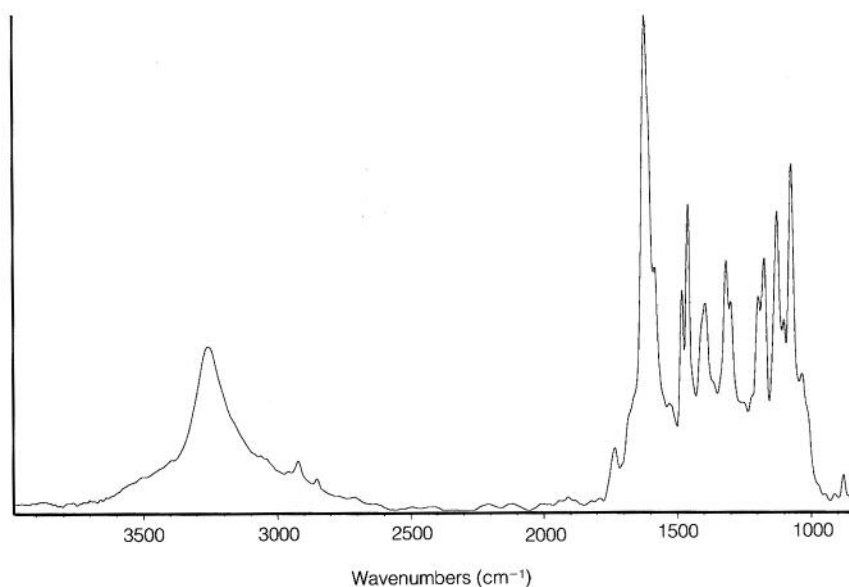



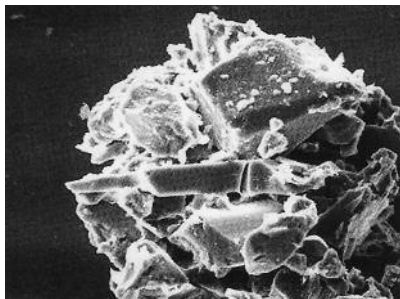

*Figure 4*

A scanning electron micrograph of the pigment smalt, imaged using secondary electrons. The sample is from an eighteenth-century polychrome sculpture. Smalt was made by adding cobalt oxide to molten glass, which was cooled and ground into fine particles. The micrograph reveals a cluster of these particles and associated paint binder. X rays emitted from the sample indicate that the pigment is composed of silicon, potassium, and cobalt.

that are emitted from the sample following an inelastic collision with the electron beam. Both types of images convey surface topography (Fig. 4). Backscatter images may also convey compositional differences within samples. Most scanning electron microscopes are equipped with one or more X-ray spectrometers that detect X rays emitted when the electron beam interacts with a sample's surface. The frequencies of these X rays are characteristic of the elements composing the area of interaction. Thus, SEMs equipped with X-ray spectrometers may be used for analysis of the elemental composition of layers or specific particles within layers. Two types of X-ray spectrometers are used: energy-dispersive spectrometers (EDS) and wavelength-dispersive spectrometers (WDS). Each technique provides a spectrum of X-ray frequencies that is used to identify constituent elements; the WDS detector also provides a map of the distribution of single elements. In a related technique called electron microprobe analysis (EMPA), an X-ray spectrometer is coupled with a compound light microscope. Both layered and particle samples may be analyzed using SEM. Samples generally are made conductive by mounting them to a support made of aluminum, carbon, or beryllium and coating them with a thin layer of carbon, gold, gold-palladium, aluminum, or chromium (new high-pressure environmental SEMs do not require this sample preparation). Some thermal decomposition may result from interaction with the electron beam, but samples can often be retrieved for further analysis.

---

## Applications

Many applications arise from simple microscopic inspection of layers and individual particles: stratigraphic analysis, study of finish history, evaluation of the progress of surface-related treatments, and determination of solubility and melting point. Microchemical and microspectroscopic techniques may be used to characterize sample composition. These applications are often complementary and interdependent. For example, stratigraphic analysis aids in identifying a particular layer within a layered structure for analysis, while composition study aids in comparing two or more layers from the same or different samples.

### Stratigraphic analysis

Layered samples are used most commonly for stratigraphic analysis and for three practical applications: (1) study of finish history, (2) evaluation of the progress of surface-related treatments, and (3) determination of solubility and melting point. The compound light microscope is the primary tool for stratigraphic analysis. Comparative examination of two or more samples, and multiple sectional planes within a single sample, helps to ensure that anomalies in a single sample do not result in erroneous conclusions. Individual layers may be differentiated by their color, fluorescence, reflectance, texture, opacity, pigmentation, and evidence of prolonged exposure and physical alteration (Fig. 5). Observations made on multiple samples, or on successively exposed cross sections of single samples, may be used collectively to sort out the number and sequence of layers, their thickness and continuity, their condition, how they have physically interacted and altered, and the distribution of particles such as pigments and grime. Layers may be further distinguished by their optical properties, solubility, melting point, and composition.

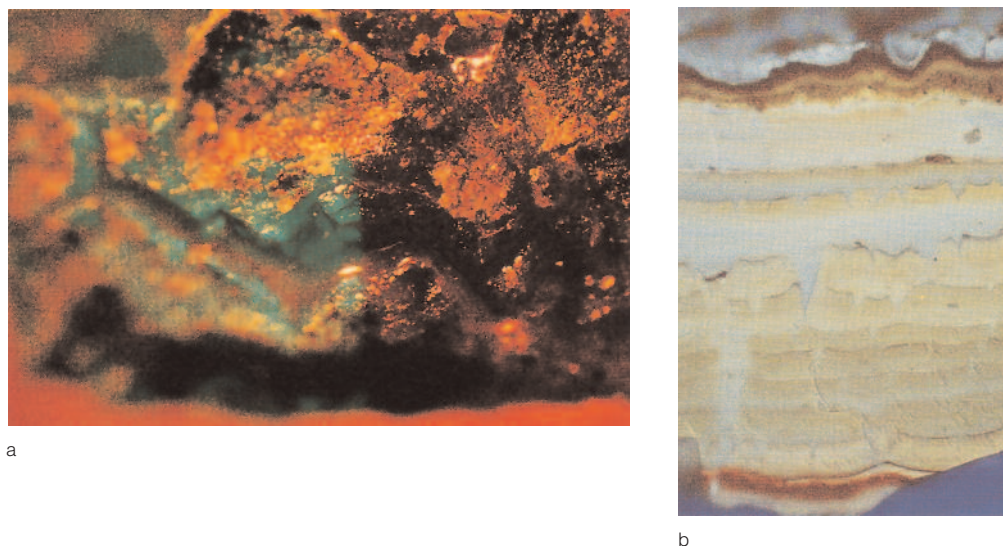

Figure 5a, b

Photomicrographs of a layered sample from a painted and varnished Concord coach. The top surface of the sample (a) is photographed in simultaneous oblique visible illumination and epifluorescence illumination (left half) and oblique visible illumination (right half), using a  $\times 4$  objective; and a cross section of the sample (b) is photographed in epifluorescence illumination, using a  $\times 10$  objective. Discolored varnish layers that are indistinguishable in visible illumination are readily distinguished in epifluorescence illumination, permitting study of layer thickness and weathering, and deposition of grime.

Conservators, curators, and art historians often want to know what the original appearance of an object was, or how many times it has been painted or varnished. Paint and varnish layers are often applied in sets of multiple layers, so each layer observed in a cross-section sample is not necessarily a separate finish. Knowledge of how finishes were created and evidence of surface exposure can help in distinguishing the layers that compose separate finishes. So-called presentation surfaces often, but not always, exhibit surface weathering, fluorescence, deposition of debris or grime, fading of pigments, and infiltration by later layers. Stratigraphic and composition analyses might suggest or confirm the presence of an original finish, but a definitive determination requires thorough surface examination and an unequivocal finding that finishes have not been completely removed.

Examination of layered samples taken before and during treatment provides a means of evaluating the progress of surface-related treatments, such as the removal of degraded varnish or overpaint. Wolbers, Sterman, and Stavroudis (1990) describe the use of a compound light microscope and layered samples to monitor the selective removal of degraded surface varnishes on a fire-damaged, tall case clock. Carlyle, Townsend, and Hackney (1990) used a scanning electron microscope to study the effects of chelating agents on the surfaces of paint films in layered samples. Numerous other applications may be imagined in which layer-specific examination and elemental or molecular analysis would be useful—for example, evaluating the penetration of cleaning systems, varnishes, and consolidants.

Knowing how an object will react to solvent and heat is beneficial when planning and implementing a treatment procedure. When surface tests are ambiguous or fail to account for the behavior of subsurface layers, solubility of layered and particle samples may be tested using liquid solvent (or other cleaning systems) or solvent vapors. Tests on layered samples permit observation of the dissolution, swelling, and undercutting of layers, and quantification of this behavior as a function of time and dimensional change. Stolow (1957–58) describes a microscopic apparatus for measuring the dimensional change associated with swelling and dissolution. A particularly interesting application of solubility testing was described by Makes (1987), who determined the rate of enzymatic hydrolysis of coating layers

in cross-section samples. Melting point may be determined on thin sections and particle samples using a melting point apparatus, a microscope hot stage, or epifluorescence illumination (Martin 1992), the last of which can induce sample-plane temperatures above 49 °C.

## Composition study

Composition studies involve the characterization or identification of a material such as a pigment, binder, or varnish. The characterization process may involve examination of visual features, as well as analysis of optical and physical properties, elemental and molecular composition, and atomic structure. Identification is made by comparing features or properties of a sample with those of known materials. Identification may be complicated or even prevented by the presence of complex mixtures or by contamination from restoration or conservation treatments. Some studies are focused only on the primary components of a sample, while others may involve analysis of trace components.

### Pigments

The conservation literature pertaining to the microscopic identification of pigments commonly used in artists' paints is expansive. Feller (1985) and Roy (1993) provide in-depth descriptions of the composition of many important traditional artists' pigments and their identification using microscopic and instrumental techniques. Definitive identification of pigments principally involves the use of polarized light microscopy; one or more additional techniques are often used for confirmation. Sometimes analysis of atomic structure using X-ray diffraction spectrometry (XRD), a nonmicroscopic technique, is used for confirmation. One sample of approximately 0.1 mm<sup>3</sup>, or 1 µg of paint, is more than sufficient for analysis of pigments using polarized light microscopy, fluorescence microscopy, infrared microspectroscopy, scanning electron microscopy, and X-ray diffraction spectrometry.

Many traditional artists' pigments may be identified, or eliminated from consideration, through the use of polarized light microscopy. Particle samples usually are dispersed on a glass slide in a medium that reduces light scatter and that has a known refractive index, thus providing a reference for measurement of the refractive index. After visually distinguishing particles by color, particles can be characterized based on physical properties, such as size and shape, and on optical properties, including refractive index, pleochroism, birefringence, and extinction. Fluorescence illumination is useful for distinguishing the presence of occasional fluorescent pigments and flakes of binder and varnish in samples. Most traditional artists' pigments exhibit a unique set of optical properties, permitting their identification using only polarized light microscopy. When unique optical properties are not observed, particular elements or chemical groups of which the pigment is composed can be identified using microchemical tests and the compound light microscope. Microchemical tests are very sensitive and may be applied to single particles, small clusters of particles, or layered samples. McCrone (1982) describes a broad range of optical, microchemical, and instrumental techniques for identification of traditional artists' pigments, including the use of a hot stage. Gettens and Stout (1936), Plesters (1956), and Masschelein-Kleiner (1986) describe a range of microchemical tests to confirm the presence of pigments in layered

samples. Modern organic pigments are more difficult to identify using polarized light microscopy because they lack highly distinctive optical features. Vesce (1942) and McCrone (1982)<sup>1</sup> describe the use of recrystallization and sublimation techniques for their identification.

Infrared microspectroscopy complements polarized light microscopy by providing information on the molecular composition of specific particles and particle aggregates. Numerous pigments have unique infrared spectra, including carbonates, chromates, oxides, silicates, sulfates, the phosphate pigment ivory black, and the nitrile pigment Prussian blue. Many traditional organic pigments—such as indigo and gamboge—and modern dyes, which are difficult to identify by polarized light microscopy, are readily identified using infrared microspectroscopy. Less than 1 µg of sample is required, and analysis is nondestructive, so samples may be used for further analysis.

Scanning electron microscopes equipped with an X-ray spectrometer, as well as electron microprobe analyzers, are used primarily to identify the elemental composition of pigments in particle or layered samples. The range of elements detected depends on the spectrometer used; most X-ray spectrometers detect elements with atomic number 11 (sodium) and above, while others detect atomic number 5 (boron) and above. The secondary use of SEM is for examination of the morphology (shape and texture) of pigments.

#### **Binders and varnishes**

Identification of natural paint binders and varnishes in aged samples often proves challenging because these materials lack highly characteristic optical properties, vary in purity, and are especially prone to degradation. Further, binders usually constitute only a minor proportion of paint films and often must be separated from pigment for analysis. Microscopic identification of paint binders and varnishes currently requires characterization of molecular composition using infrared microspectroscopy. Erhardt and coworkers (1988) and Pilc and White (1995) describe systematic approaches for classification of natural coatings and binding media (e.g., oil) using infrared microspectroscopy, followed by identification of specific materials (e.g., linseed oil) using gas chromatography. Derrick and coworkers (1992) and Derrick (1989) describe the layer-specific identification of shellac, copal, sandarac, mastic, and rosin in thin-section samples from coated furniture, using infrared microspectroscopy. Kühn (1960) describes similar specificity in identifying waxes, and infrared analysis of other paint binders, such as oil and egg, have been described in the literature (Van't Hul-Ehrnreich 1970; Meilunas, Bentsen, and Steinberg 1990). Synthetic paint binders and varnishes are readily classified to type and material by infrared microspectroscopy (Lomox and Fisher 1990).

Before infrared microspectroscopy became a practical tool for analysis in the early 1980s, the molecular composition of microscopic samples of binders and varnishes could not be readily determined. Binders and varnishes were characterized by their physical and chemical properties using compound light microscopes and a variety of solubility and melting point tests, as well as microchemical reactions and stains. Caution has to be exercised when interpreting and presenting the results obtained with these techniques; staining techniques, in particular, rely on subjective visual appraisals of color change and are prone to misinterpretation. Gettens and Stout (1936), Plesters (1956), and Mills and White (1994)

review the principal techniques for microscopic analysis of binders and varnishes at different times during this century. Masschelein-Kleiner and coworkers describe a systematic approach for analysis of binding media in cross section, thin section, and particle samples (Masschelein-Kleiner, Heylen, and Tricot-Marckx 1968; Masschelein-Kleiner 1986). Some of these tests involve simple solubility in water, organic solvents, or acids and alkalis. Other tests involve determination of melting point or a specific element, such as nitrogen or phosphorous. Microscopic staining techniques have been used to distinguish between oil and protein binders since the early part of this century; more recently, staining techniques have been proposed for detection of natural resins and carbohydrates. Stains are often used to enhance contrast in synthetic polymers for microscopic examination, but no staining techniques exist for their identification. Ostwald (1935), Gettens (1935), Plesters (1956), Gay (1978), Johnson and Packard (1971), and Masschelein-Kleiner (1986) describe the use of stains that are viewed in visible light. Johnson and Packard (1971), Talbott (1982), Wolbers and Landrey (1987), and Messinger (1992) describe fluorescent staining techniques.

## Practical Approaches

Thus far, this article has described several types of samples and microscopic techniques used in the examination and analysis of paint and varnish layers, as well as common applications. This final section describes a practical approach used for analysis of stratigraphy, pigments, binders, and varnishes on a carved bedstead from the collection of Agecroft Hall.

### Examination and analysis of the Burderop Park bedstead

Elsewhere in this volume, Elizabeth Howard Schmidt describes the recent art historical and technical investigation of the Burderop Park bedstead at Agecroft Hall. The primary objective of the technical investigation was to determine the finish history of the bedstead and the composition of select layers. Howard Schmidt describes her interpretation of the results obtained by microscopic examination and analysis. Seven layered samples, a painted wooden plug from a bed rail, and a section of carved and decorated molding were studied. Three microscopes were used for the technical study: (1) a compound light microscope equipped for individual or simultaneous oblique visible, epifluorescence, and transmitted polarized illumination; (2) an infrared microscope; and (3) a scanning electron microscope equipped with an energy-dispersive spectrometer.

The wooden plug and molding were placed directly on the stage of the compound light microscope for examination using oblique visible and epifluorescence illumination. By focusing up and down along the edges of paint loss and abrasion, the layers observed in the cross-section samples could be distinguished by their color, fluorescence, reflectance, and thickness (Fig. 6). This permitted layer-specific particle samples to be taken from the plug and the molding instead of the layered samples, which would have required thin-sectioning with a microtome.

The earliest extant layer observed was an amber-colored, fluorescent coating (B in Fig. 6). In cross-section samples, the coating appeared discontinuous and was too thin to be sampled for composition study. On the molding, the layer was observed at areas of paint loss, beneath several lifting flakes of paint, and on the underside of a detached

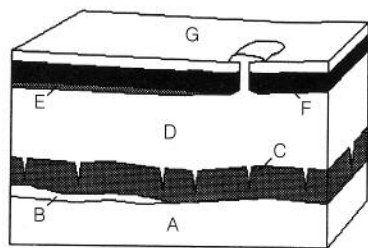

*Figure 6*  
Idealized schematic representation of paint and varnish layers observed in layered samples and on a molding section from the Burderop Park bedstead, Agecroft Hall: A = carved wood substrate, B = discontinuous amber-colored coating, C = fissured red paint layer, D = buff priming and paint layer, E = red graining layer, F = polychrome layers, and G = surface varnish.

flake. The layer was absent from the wooden plug. A series of hardness and solubility tests performed directly on the molding indicated that the coating was extremely brittle and immediately soluble in acetone. These properties usually are associated with, but not necessarily indicative of, natural resins. Solubility testing also provided important practical information that indicated that similar polar solvents could not be used for the conservation treatment. Solvent was wicked beneath the surrounding paint layers, leaving the layers mobile atop the fluid coating; after one hour, the coating remained sufficiently fluid that slight pressure caused it to erupt from cracks several millimeters away.

For characterization, a microgram sample of the powdered coating was removed with a metal probe from a protected area under a lifting paint flake. The sample was transferred directly to a diamond cell used for infrared microspectroscopy. Examination of the sample with the compound light microscope, using epifluorescence and transmitted polarized light, revealed uniform color and fluorescence, and scattered wood fibers within the sample. The diamond cell was transferred to the infrared microscope, and an area of the sample that was void of wood fibers was isolated for transmitted infrared analysis. The infrared spectrum of the sample indicated the presence of a natural resin and was matched with reference spectra for pine resin (Fig. 7). Samples of the wood surface and the red paint layer were analyzed in a similar manner to verify that the coating sample had not been contaminated. Infrared analysis of the wood revealed a mixture that included cellulose (wood fibers). Spectral subtraction of cellulose from the spectrum yielded a *difference spectrum* that compared favorably with pine resin (Fig. 7).

Infrared analysis of the red paint sample revealed the presence of a protein binder and lead white pigment (Fig. 8). A portion of the red paint sample was then dispersed on a glass slide and covered with a mounting medium and cover glass. Analysis using polarized light microscopy confirmed the presence of lead white pigment and indicated the presence of

*Figure 7*  
Partial infrared absorbance spectra of a sample of the first varnish layer from the Burderop Park bedstead (top); one reference sample of pine resin (middle); and the wood surface after spectral subtraction of cellulose (bottom), showing the presence of pine resin.

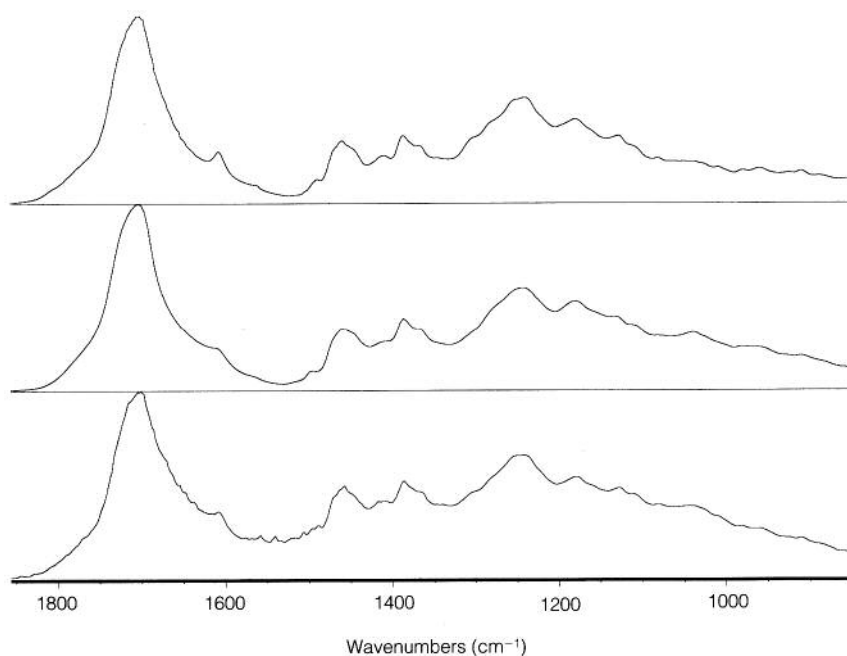

*Figure 8*

Partial infrared absorbance spectra of the first red paint layer from the Burderop Park bedstead (top) and a reference sample of animal glue and lead white pigment (bottom).

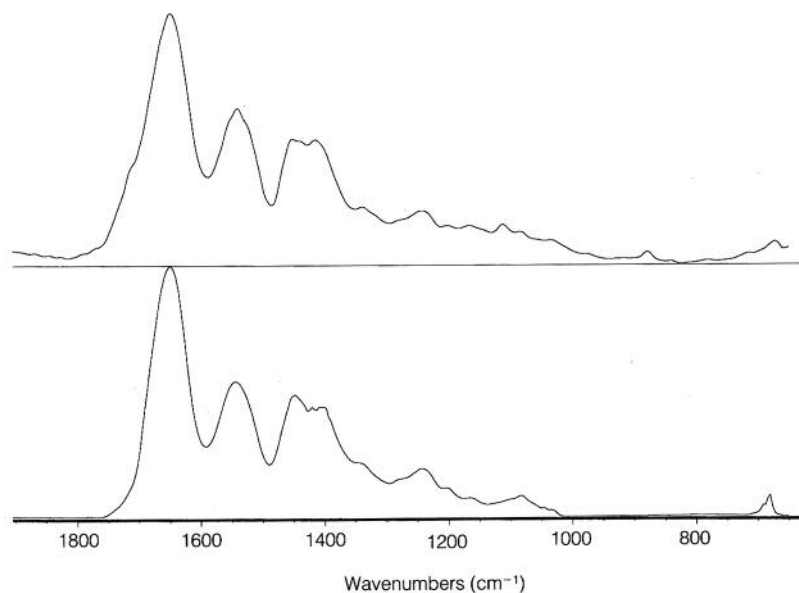

red iron oxide pigment. Another portion of the sample was mounted to an aluminum stub, coated with carbon, and analyzed using a scanning electron microscope equipped with an energy-dispersive spectrometer (SEM-EDS), which provided rapid determination of the elemental composition of the paint and confirmed the presence of lead and iron in the sample. In the absence of SEM-EDS, these elements could have been confirmed using a microchemical test for  $\text{Pb}^{2+}$  and  $\text{Fe}^{2+}$  ions, respectively. Severe surface fissuring in cross-section samples and cracking and cupping in the molding sample provided evidence that the red paint layer had weathered as a presentation surface before application of the buff-colored paint.

Surface examination also revealed that the buff paint was used beneath each of the polychrome layers and as one of the polychrome colors. Analysis of the buff paint layer revealed the presence of an oil binder, lead white pigment, and a minor amount of red iron oxide pigment. Raking visible light accentuated the surface relief of the molding and revealed that the buff paint layer had migrated to the surface through cracks in the subsequently applied polychrome layers and surface varnish, suggesting that these layers were probably contemporaneously applied as a single finish set. Solubility testing of the surface varnish revealed that it was slowly gelled without dissolution on application of acetone or ethanol. Incident pressure with a metal probe caused the varnish to chip, indicating greater cohesive strength than the amber-colored varnish, which powdered. Infrared analysis revealed the varnish to be a different natural tree resin, possibly copal.

Microscopic examination and analyses indicated the presence of three separate finishes. The first finish consists of pine resin. The second finish consists of lead white and red iron oxide in a protein binder. The third and present finish consists of a buff-colored priming-polychrome layer, a red graining layer, various polychrome layers, and a natural resin varnish.

---

## Conclusions

Since the early 1900s, light microscopy has been the primary tool for examination of the layers constituting painted and coated surfaces, as well

as characterization of component materials. In recent years, electron microscopes have increased the useful magnification and resolution of microscopic images, and spectrometers have been coupled with both compound and electron microscopes to permit rapid analysis of elemental and molecular composition. These techniques permit a wide range of applications that are used by conservators, curators, and art historians in their work to conserve, interpret, and authenticate historic and artistic works. Ongoing developments in digital imaging, optics, and spectroscopy will undoubtedly have a profound impact on the design and use of microscopes in the next century.

## Appendix

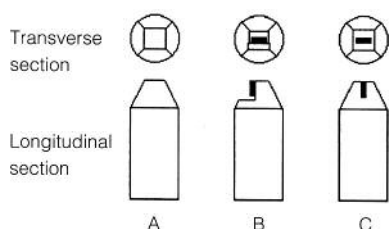

*Figure 9*  
Schematic representation of a blank capsule (A), a capsule with a shelf-mounted sample (B), and a slot-mounted capsule (C).

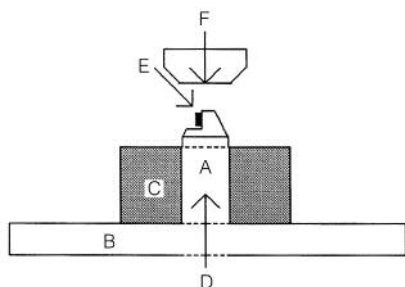

*Figure 10*  
Schematic representation of a capsule-mounted sample (A), being held on a microscope stage (B) with a capsule chuck (C), permitting individual or simultaneous illumination using transmitted polarized light (D), oblique visible light (E), and epifluorescence light (F).

## A Nontraditional Approach to the Preparation and Examination of Layered Samples

A nontraditional approach to preparation of layered samples was developed and is used at the Williamstown Center. This approach uses lifting or detached flakes as temporary samples, when possible, for stratigraphic analysis and for provision of subsurface particle samples. If the flake presents a smooth planar cross section, it can be positioned on a tacky adhesive (for example, acrylic resin, poly[ethylene/vinyl acetate] resin, cellulose ether, or wax) and examined with a compound light microscope or a scanning electron microscope. Flakes that do not present a smooth edge may be mounted to a plastic block using a similar adhesive, or held in a spring-loaded microvise, so an edge of the sample can be microtomed to yield a smooth cross-sectional plane. Following examination, the flake may be returned to its source with minimal alteration, using the mounting adhesive as a consolidant. Provided that the flake comes from a representative area, such samples are ideal for use in comparative finish history and evaluation of the progress of surface-related treatment.

A modified capsule-embedding technique for mounting, sectioning, and examining of other layered samples is described in the literature (Martin 1991). Using either an insoluble or a soluble polymer, samples are mounted to a shelf cut into the tip of a capsule block that was cast from a tapered mold (Fig. 9). The top and edges of the sample are left exposed to permit comparative examination with the prepared cross-section edge or the removal of particle samples for composition study. Because the sample is positioned at the tip of the capsule, only a very small amount of material is removed to expose a cross-section plane. The capsule mount is placed in a simple homemade chuck that registers the sample perpendicular to an abrasive sheet, microtome knife, or microscope stage (Fig. 10). Since no leveling medium is used, cross-section samples may be illuminated with transmitted polarized light to observe the presence of birefringent particles in transparent coating layers around the perimeter of the sample. If complete embedment is required for sectioning, additional medium is added to cover the sample. The capsule mounts may be stored in commercially available boxes. This approach has been adopted by many conservation labs and is easily tailored to individual working techniques.

## Note

1 Please note errata in McCrone 1982: refractive indexes were transposed for the isotropic blue pigments in Figure 7, and terre verte and verdigris in Figure 8.



---

**References**

- Birk, G.  
1984 *Instrumentation and Techniques for Fluorescence Microscopy*. Sydney: Wild Leitz.
- Carlyle, L., J. H. Townsend, and S. Hackney  
1990 Triammonium citrate: An investigation into its applications for surface cleaning. In *Dirt and Pictures Separated*, 44–48. London: United Kingdom Institute for Conservation of Historic and Artistic Works (UK-IIC).
- De la Rie, E. R.  
1986 Ultraviolet radiation fluorescence of paint and varnish layers. *PACT* 13:91–108.
- Derrick, M.  
1989 Fourier-transform infrared spectral analysis of natural resins used in furniture finishes. *Journal of the American Institute for Conservation* 28(1):43–56.
- Derrick, M. R., J. M. Landry, and D. C. Stulik  
1991 *Methods in the Scientific Examination of Works of Art: Infrared Microspectroscopy*. Marina del Rey, Calif.: Getty Conservation Institute.
- Derrick, M., L. Souza, T. Kieslich, H. Florsheim, and D. Stulik  
1994 Embedding paint cross-section samples in polyester resins: Problems and solutions. *Journal of the American Institute for Conservation* 33(3):227–45.
- Derrick, M. R., D. Stulik, J. M. Landry, and S. P. Bouffard  
1992 Furniture finish layer identification by infrared linear mapping spectroscopy. *Journal of the American Institute for Conservation* 31:225–36.
- Erhardt, D., W. Hopwood, M. Baker, and D. Von Endt  
1988 A systematic approach to the instrumental analysis of natural finishes and binding media. In *AIC Preprints, 16th Annual Meeting, American Institute for Conservation, New Orleans, Louisiana*, 67–84. Washington, D. C.: American Institute for Conservation of Historic and Artistic Works (AIC).
- Feller, R., ed.  
1985 *Artists' Pigments: A Handbook of Their History and Characteristics*. Vol. 1. Cambridge: Cambridge University Press.
- Garrido, M. del C., and J. M. Cabrera  
1986 Cross-sections. In *PACT* 13:155–69.
- Gay, M. C.  
1978 Application of the staining method to cross-sections in the study of the media of various Italian paintings of the fourteenth and fifteenth centuries. In *Conservation and Restoration of Pictorial Art*, ed. B. Bromelle and P. Smith, 78–83. London: Butterworths.
- Gettens, R. J.  
1935 Microscopic examination of specimens from an Italian painting. *Technical Studies in the Field of the Fine Arts* 3(3):165–73.
- 1936 The cross-sectioning of paint films. *Technical Studies in the Field of the Fine Arts* 5(1):18–22.
- 1940 The use of methyl methacrylate in the preparation of polished specimens of friable materials. *Technical Studies in the Field of the Fine Arts* 9(2):113–16.
- Gettens, R. J., and G. L. Stout  
1936 The stage microscope in the routine examination of paintings. *Technical Studies in the Field of the Fine Arts* 4(4):207–33.

- Hanson, V. F.  
1970 The curator's dream instrument. In *Applications of Science in Examination of Works of Art: Proceedings of the Seminar, June 15–19, 1970*, ed. William J. Young, 18–30. Boston: Museum of Fine Arts.
- Harrick, N. J.  
1967 *Internal Reflection Spectroscopy*. New York: Wiley-Interscience.
- Hemsley, D. A.  
1989 Basic light microscopy and the phase contrast microscope. In *Applied Polymer Light Microscopy*, ed. D. A. Hemsley, 39–72. New York: Elsevier Science Publishing.
- Hoeniger, C.  
1991 The identification of blue pigments in early Sieneese paintings by color infrared photography. *Journal of the American Institute for Conservation* 30(2):115–24.
- Hoffman, R.  
1989 Modulation contrast and differential interference contrast techniques. In *Applied Polymer Light Microscopy*, ed. D. A. Hemsley, 151–84. New York: Elsevier Science Publishing.
- Johnson, M., and E. Packard  
1971 Methods used for the identification of binding media in Italian paintings of the fifteenth and sixteenth centuries. *Studies in Conservation* 16:129–44.
- Kühn, Hermann  
1960 Detection and identification of waxes, including Punic wax, by infra-red spectrography. *Studies in Conservation* 5(2):71–79.
- Larson, L. J., K.-S. K. Shin, and J. I. Zink  
1991 Photoluminescence spectroscopy of natural resins and organic binding media of paintings. *Journal of the American Institute for Conservation* 30:89–104.
- Laurie, A. P.  
1914 *The Pigments and Mediums of the Old Masters*. London: Macmillan.
- Lomax, S. Q., and S. L. Fisher  
1990 An investigation of the removability of naturally aged synthetic picture varnishes. *Journal of the American Institute for Conservation* 29:181–91.
- Makes, F.  
1987 Analysis and conservation of the picture *Rudolph II* by G. Archimboldi. In *ICOM Committee for Conservation Preprints, 8th Triennial Meeting, Sydney, Australia, 6–11 September 1987*, 173–78. Marina del Rey, Calif.: Getty Conservation Institute.
- Malis, T. F., and D. Steele  
1990 Ultramicrotomy for materials science. In *Workshop on Specimen Preparation of TEM Materials*, ed. R. Anderson, 3–43. Vol. 2 of *Materials Research Society Symposium Proceedings*. Pittsburgh: Materials Research Society.
- Martin, J. S.  
1991 Observations on cross-section examination of painted and coated surfaces. In *1991 AIC Paintings Specialty Group Postprints*, comp. Chris Stavroudis, 39–42. Washington, D.C.: AIC.
- 1992 Update on innovative techniques for preparation and microscopic analysis of sectional samples. Report, Williamstown Art Conservation Center, Williamstown, Va.
- Masschelein-Kleiner, L.  
1986 Analysis of paint media, varnishes, and adhesives. *PACT* 13:185–207.

- Masschelein-Kleiner, L., J. Heylen, and F. Tricot-Marckx  
1968 Contribution à l'analyse des liants, adhésifs et vernis anciens. *Studies in Conservation* 13(3):105–21.
- McCrone, W. C.  
1982 The microscopical identification of artists' pigments. *Journal of the International Institute for Conservation, Canadian Group* 7(1–2):11–34.
- McCrone, W. C., and J. G. Delly  
1978 *Polarized Light Microscopy*. Ann Arbor, Mich.: Ann Arbor Science Publishers.
- Meilunas, R. J., J. G. Bentsen, and A. Steinberg  
1990 Analysis of aged paint binders by FT-IR spectroscopy. *Studies in Conservation* 35(1):33–51.
- Messinger, J.  
1992 Ultraviolet-fluorescence microscopy of paint cross sections: Cycloheptaamylose-dansyl chloride complex as a protein-selective stain. *Journal of the American Institute for Conservation* 31(3):267–74.
- Mills, J., and R. White  
1994 *The Organic Chemistry of Museum Objects*. 2d ed. London: Butterworths-Heinemann.
- Ostwald, W.  
1935 Iconoscopic studies, 1: Microscopic identification of homogenous binding mediums. Trans. H. Zeishold. *Technical Studies in the Field of the Fine Arts* 4:135–44.
- Pilc, J., and R. White  
1995 The application of FTIR-microscopy to the analysis of paint binders in easel paintings. *National Gallery Technical Bulletin* 16:73–84.
- Plesters, J.  
1956 Cross sections and chemical analysis of paint samples. *Studies in Conservation* 2(3):110–55.
- Reedy, T. J., and C. L. Reedy  
1988 *Statistical Analysis in Art Conservation Research*. Research in Conservation. Marina del Rey, Calif.: Getty Conservation Institute.
- Reffner, J. A., and P. A. Martoglio  
1995 Uniting microscopy and spectroscopy. In *Practical Guide to Infrared Microspectroscopy*, ed. Howard J. Humecki, 41–84. New York: Marcel Dekker.
- Roy, A., ed.  
1993 *Artists' Pigments: A Handbook of Their History and Characteristics*. Vol. 2. Washington, D.C.: National Gallery of Art.
- Slyter, E. M., and H. S. Slyter  
1992 *Light and Electron Microscopy*. Cambridge: Cambridge University Press.
- Stolow, N.  
1957–58 The measurement of film thickness and of solvent action on supported films. *Studies in Conservation* 3:40–44.
- Talbott, R.  
1982 The fluorescent antibody technique in the identification of proteinaceous materials. In *Papers Presented by Conservation Students at the Third Annual Conference of Art Conservation Training Programmes*, 140–49. Ontario: Queens University.

- 1991 **Tsang, J.-S., and R. Cunningham**  
Some improvements in the study of cross sections. *Journal of the American Institute for Conservation* 30:163–77.
- 1986 **van Asperen de Boer, J. R. J.**  
Examination by infrared radiation. *PACT* 13:109–30.
- 1986 **Van Schoute, R., and H. Verougstraete-Marcq**  
Radiography. *PACT* 13:131–53.
- 1970 **Van't Hul-Ehrnreich, E. H.**  
Infrared microspectroscopy for the analysis of old painting materials. *Studies in Conservation* 15(3):175–82.
- 1942 **Vesce, V.**  
The microscopic identification of azo dyes and organic pigments. In *Protective and Decorative Coatings*, vol. 2, ed. J. J. Mattiello, 124–63. New York: Wiley.
- 1987 **Wolbers, R., and G. Landrey**  
The use of direct reactive fluorescent dyes for the characterization of binding media in cross-sectional examinations. In *AIC Preprints, 15th Annual Meeting, American Institute for Conservation, Vancouver, British Columbia*, 168–203. Washington, D.C.: AIC.
- 1990 **Wolbers, R., N. Serman, and C. Stavroudis**  
*Notes for Workshop on New Methods in the Cleaning of Paintings*. Marina del Rey, Calif.: Getty Conservation Institute.

PART TWO

# Historical Perspectives



# Support and Polychromy of Altarpieces from Brussels, Mechlin, and Antwerp

## Study, Comparison, and Restoration

*Myriam Serck-Dewaide*

COMPOSITE ALTARPIECES, comprising painted and sculpted elements (really pieces of liturgical furniture) had already appeared in great number by the middle of the fourteenth century in different regions. They functioned at this time as tabernacles,<sup>1</sup> and cupboards for relics and for individual figures of saints and narrative scenes. Gilded architectural elements, baldachins,<sup>2</sup> and rhythmic colonnettes strictly compartmentalized the space. The painted wings served to close these “cases,” revealing the figures to the faithful only on feast days.

Altarpieces were popular throughout Europe in the fifteenth and sixteenth centuries. The regional workshops—for example, Germanic, Franco-Flemish, Spanish, and Italian—evolved differently, varying the dimensions, space, perspective, lighting, and polychromy of the altarpieces (Skubiszewski 1989).

Only altarpieces from the historic Brabant region<sup>3</sup> are considered here—in particular, the sculpted parts of these Brabantine altarpieces. In the fifteenth century, Brabantine altarpieces evolved toward a more realistic expression and a more accentuated relief. Compositions were grouped in successive arrangement, presenting scenes of small characters, related as in a theatrical setting. Over time, the architecture changed, reducing in size, until eventually there was no more than a frame presenting scenes consecrated to the Virgin, to the lives of the saints, or to cycles of the infancy and Passion of Christ. This evolution progressed very slowly during the mid–sixteenth century, from late Gothic decoration to Renaissance motifs. From the second half of the fifteenth century, Brabantine altarpieces became so successful that, in order to satisfy the demand, a division of labor became necessary. The production of altarpieces was divided between the hutch maker,<sup>4</sup> the sculptors of the architectural elements, the sculptors of the figures, the gilders, the polychromists, and the painters (Jacobs 1989).

The regulations of the guilds were very strict. It was mandatory that the works be marked as a way of guaranteeing their place of origin and their quality. This method of serial production reflected a systematization in the formal creation of the altarpieces and in the application of the polychromy in the principal Brabantine workshops.

## The Brussels Workshops

The Brussels workshops produced altarpieces in oak and in walnut. Architectural elements and the hutch<sup>5</sup> were in oak, and the paintings of the wings on oak supports. Walnut was used especially around the middle of the fifteenth century to create sculpted groups from a single block. Each compartment was composed of a block containing a composition of five to eight figures. The customary forms are rectangular with a raised central compartment. There are often three—or, occasionally, five—compartments for the large altarpieces (Fig. 1). Colonnettes and pinnacles separate the scenes and support the canopies. Pierced friezes decorate the bases of the altarpieces.

It is known from guild documents, notably those dating from 1453 to 1455, that quality control was regulated by marks (Nieuwdorp 1981, 1993). The hutch was marked with a compass and plane, the sculptures with a mallet, and the polychromy with a “BREUSEL” punch in the gilding (Fig. 2). Still other marks are occasionally found, such as a Gothic letter J or a flower, which are considered personal.<sup>6</sup> In addition, marks or numerical notations denoting position can be found on the architectural elements.<sup>7</sup>

At the end of the fifteenth century, the sculptures and the composition of the altarpieces became complex. The fragments were systematically cut in quartersawn oak, and they were no longer carved in a single block, but rather in a series of blocks perfectly accommodating each other, either one behind the other or side by side. Marks from the rotatable vice can often be seen on the heads of the figures and marks from long knives on the underside of the base. The mounting of the hutch, the architectural elements, and the sculptures is remarkable. The assemblages are fashioned with dovetails (above the case), mortise and tenons, and pins. The wood of the hutches from Brussels shows signs of cleaving less often than that in hutches from Antwerp because even the wood at the back of the Brussels cases was often reworked (sawed, smoothed, planed); consequently, the marks of the woodcutter are less often found (Glatigny 1993).<sup>8</sup>

Figure 1

Brussels altarpiece from Saluzzo, ca. 1500. In the collection of the Maison du Roi, Brussels.

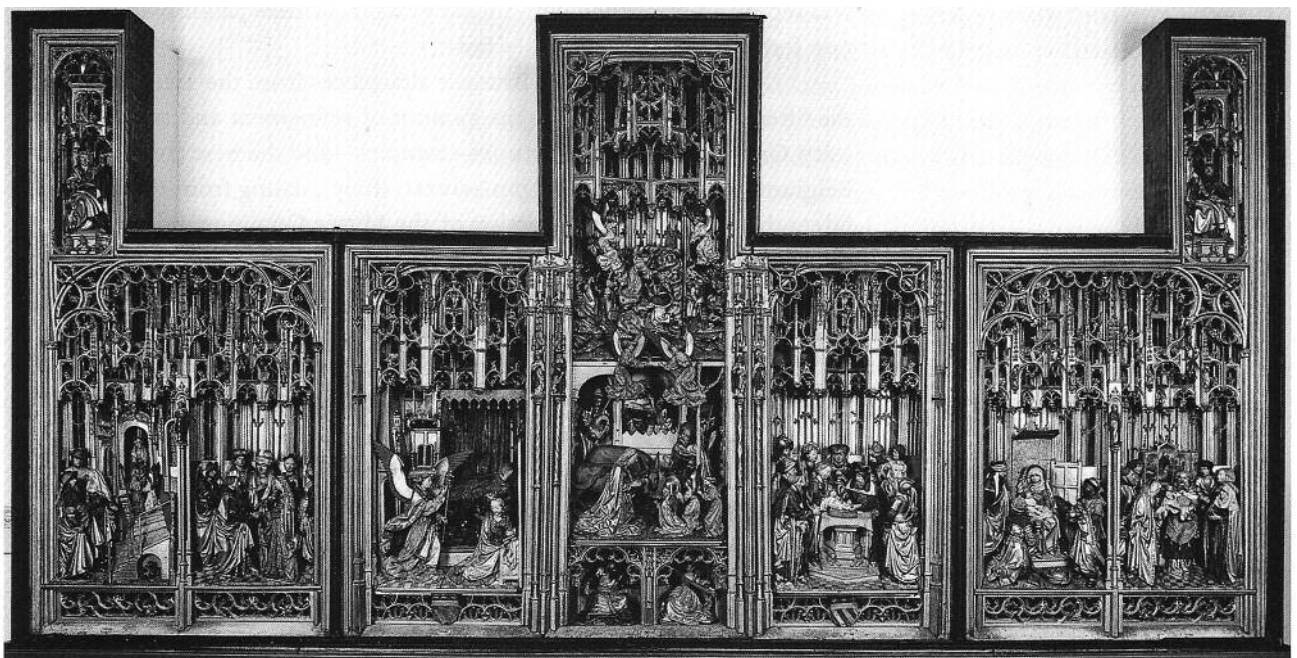

Figure 2a–c

Sketches of marks found on altarpieces.

(a) Brussels, top row: the compass and plane (hutch maker's mark); the mallet (sculptor's mark); the BRUESEL punch (polychromy mark struck into the gilding); second row: the flower, the letter J (examples of personal marks struck in the wood of the case).

(b) Mechlin: the shield (mark of hutch makers and sculptors); the letter M (polychromy mark struck into the gilding); the wheel (example of personal mark struck into the wood); the square (personal polychromy mark).

(c) Antwerp: the hand (sculptor's mark); the castle and hands (the final guild mark on the case and wings).

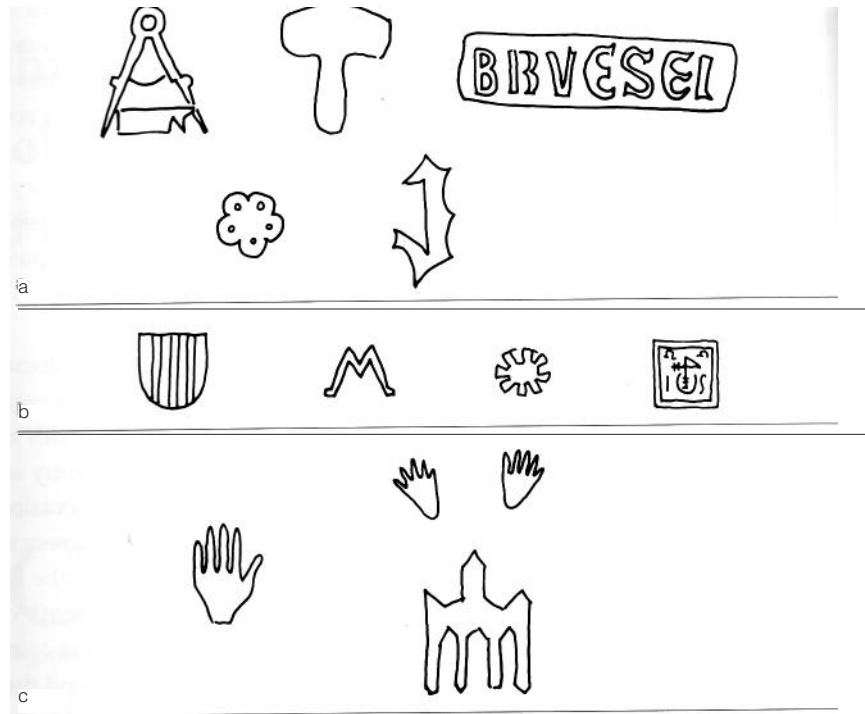

The architectural elements were dowelled and adhered with animal glue. They were then coated with a white ground<sup>9</sup> composed of chalk and animal glue. Two layers of ground generally sufficed for the fine tracery of Gothic arcades destined to receive a matte oil gilding, with ochre added to the oil mixture. Broad areas and larger parts of the arcades were covered with more ground layers to prepare them for the burnishing of the gold, applied on a pink-orange bole. The sculptures were coated with the same ground, most often in similar thickness; hair, faces, hands, fine decoration, and landscape areas received only two or three thin layers, while the garments or those areas that were intended to receive gilding—in burnished gold or silver—were covered in five to ten layers. The ground was recut and smoothed with marsh grass (*Equisetum palustre*) in preparation for application of the polychromy.

The polychromy of Brussels altarpieces from the second half of the fifteenth century reaches the summit of refinement and artistic virtuosity. One of the most sumptuous examples—and the best conserved in Belgium—is the altarpiece from Saluzzo (Italy), dating from the end of the fifteenth century, in the collection of the Musée Communal de la Maison du Roi, located in the Grand Place in Brussels (Fig. 1) (Fichet 1965). The stages and the components of the polychromy are as follows: the pink-orange bole was applied very cursorily in the areas intended to receive gilding. In certain instances, a gray bole has been found under silver leaf—for example, under the silvering of a small domestic altarpiece of the Nativity from the same museum.

With the application of the ground and bole to the fragments completed, a kind of stage setting was created by placing the individual elements first in the background plane, then the middle plane, and finally in the foreground plane. The middle and foreground figures conceal the bases of those of the background. Incisions were made in the bole to define those areas intended to receive the gilding, so areas that would not be seen



Figure 3  
Brussels altarpiece from Saluzzo. Detail of  
applied brocade on the canopy.

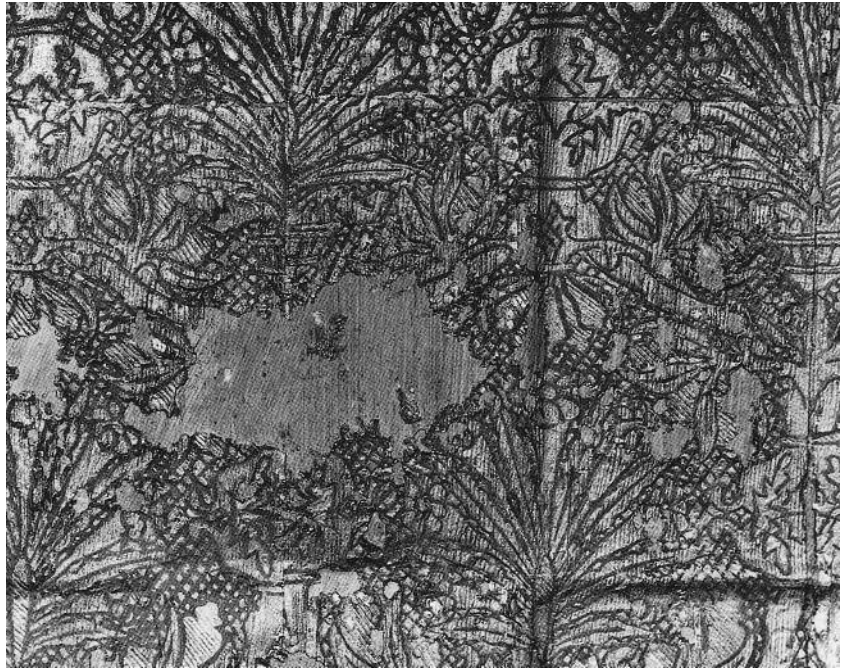

would not be gilded. After application of the metal leaf by water gilding, and after burnishing, the next step was probably decoration by punching.

A typical decoration of Brussels altarpieces is the imitation of richly embroidered textiles, achieved by the technique of applied brocade<sup>10</sup> (Ballestrem 1968; Serck-Dewaide 1990). Certain canopies and garments received complete brocades of the lean type, rectangular leaves in relief that were prepared in a mold. These decorations on Brussels altarpieces are extremely fine. Each mold was engraved with a textile motif, then covered by a leaf of tin (as a releasing agent). A small amount of liquid ground material was then poured, while lukewarm, into the mold. After drying and removal from the mold, the brocade leaves were glued onto the paintings or sculptures. They were gilded in place (matte oil gilding) and then embellished with fine blue or red painted decorations (Fig. 3).

Other parts received local brocades laid down on a colored glaze applied over silver. There are two examples in the scene of the Annunciation in the Saluzzo altarpiece: the decoration of the eagle in gilded relief on red glaze over silver on the bed cover, and the floral decorations on a green glaze laid over burnished silver on the decoration of the baldachin. In the latter, there is an added refinement: the green glaze is applied in one layer; then the gilded brocade is “glued” to the undried glaze. Once dry, a second layer of glaze is applied, using a fine brush to contour these motifs in relief and to form a decoration of darker tonalities in thick glaze. Finally, the same technique was used for the borders of glued brocades (or orphreys) on the mantle of the Angel Gabriel (Fig. 4).

Other decorations typical of Brussels altarpieces, but rarely preserved, are the metallic decorations in relief: small “cups” in copper (or alloy) pressed into the fresh pictorial layer of glaze or oil paints. Three altarpieces still in Belgium have these decorations.<sup>11</sup>

Representations of stained glass windows are made with remarkable realism in Brussels altarpieces: burnished silver leaf on bole is covered

Figure 4  
Brussels altarpiece from Saluzzo. Scene of the  
Annunciation.



with a somewhat greenish glaze and finished by a network of fine black lines to represent the leads. The blues are deep azurite on light blue. The azurite may be crystalline, pure, matte and coarsely ground, applied on a black ground in an aqueous medium. It is found on most of the linings of the garments, simulating velvet.

A few blue dresses have decorations of small gold dots, seemingly achieved with shell gold (powdered gold bound in gum arabic). On certain garments, the blue azurite areas are strewn with small cut-and-gilded brocade motifs. The azurite may also be ground more finely, mixed with white lead, or on a yellow or reddish ground bound in a glue, an oil, or a mixed medium. These blues decorate hats and cloaks, and they are often outlined by red or blue piping. The flesh tones are also extremely refined. They are often smooth, like porcelain—rather white for the female figures and redder for the males. Fine, precise oil strokes finish off the details of the eyes, eyelids, eyebrows, circles around the eyes, mouth, fingernails, blood, and sometimes even tears.

The decoration of areas depicting the floor or ground varies according to whether an interior or exterior space is represented. The interiors are decorated by a tile pavement, with the lines in perspective, often engraved into the ground layer. The entire area is leaf-gilded with an ochre colored oil, and afterward each alternating tile is coated with green (copper resinate) or red glaze. The outdoors is suggested by a grassy earth, sometimes worked by a technique known as *tremolierungen*<sup>12</sup>—as observed in the altarpiece dedicated to the life of Saint George (signed and dated by

Jan Borman, 1498) and in the small domestic altarpiece of the Passion (both in the collection of the Musées Royaux d'Art et d'Histoire, Brussels), as well as in the Saluzzo altarpiece (Maison du Roi). To produce invisible joins, these areas were filled with a thick putty, or paste, composed of animal glue and wood powder. This material was occasionally also applied on the surfaces as an alternate method of representing grass. Matte gold was then applied to these areas, which were then partially covered with malachite green in an aqueous or mixed medium, and then covered with a green glaze of copper resinate.

These finishing touches of matte gold, color, and glazes were applied after the last mounting of the altarpiece. Finally, a very fine protective layer of animal glue was applied on the burnished gold (called "matting of the gold" in the seventeenth century) (Serck-Dewaide 1991).

It should be emphasized that all Brabantine altarpieces were originally polychromed. Because many altarpieces were stripped of their polychromy during the nineteenth century, certain art historians have written that some Brabantine altarpieces were meant to remain bare wood, locally tinted and colored, like those of Tilman Riemenschneider or other sculptors of the German Renaissance. These suggestions are erroneous; each time a "bare wood" altarpiece has been studied or restored, traces of polychromy have been found, or texts from the nineteenth century requesting the removal of the polychromy have been discovered.

---

## The Mechlin Workshops

The Mechlin<sup>13</sup> workshops produced works contemporaneous with those of the sumptuous period of the Brussels workshops (end of the fifteenth century) and with those of Antwerp's great production (first half of the sixteenth century). Like the Brussels and Antwerp workshops, the Mechlin workshops created a few altarpieces of historic scenes—such as those in Odeby, Sweden (Derveaux-Van Ussel 1973b); Aachen Museum, Germany (Nieuwdorp 1993:20–21); the church of Clerey, France (Derveaux-Van Ussel 1973a); and *Deutschordenskirche* (the Church of the Teutonic Knights) (Koller 1995:90–104) in Vienna, Austria (Van Doorslaer 1933:170). More often, however, they created small, domestic altarpieces that were rectangular in shape, had painted wings, and contained three statuettes commonly called Malines (Mechlin) dolls. The best known examples are the altarpieces conserved at the Musée Mayer van den Bergh in Antwerp (Coo 1969:202–3), such as the one shown in Figure 5, and the altarpiece from the Loze-Corswaremme collection. The single statuettes are ubiquitous, representing different male and female saints and also the Infant Jesus, nude and standing on a socle (Godenne 1972).<sup>14</sup> The height of these statuettes is rather regular, the small format being 12.5 cm, the most common being 33–34 cm, and the largest 45 cm. The dolls are almost always in walnut, while the bases, the architectural elements, and the hutches are in oak.

The construction of the Mechlin hutches is very similar to that of the hutches of the Brussels school: pierced railings at the base, separating colonnettes, background fenestration. Only the decoration of the concave and convex brackets of the canopy<sup>15</sup> (serving as parentheses) distinguishes them.

The marks on these altarpieces reveal the complexity of the work's organization, collaboration between the different centers, and the options of the clients. The marks of the Mechlin guild of hutch makers and sculptors,

whose stamp was a shield with three pales, can be seen on the cases or on the backs or bases of the Malines dolls; but the mark of Brussels (BRUESEL) may also be found on the polychromy of these dolls, or the mark of the compass on the case containing the dolls.<sup>16</sup> Consequently, it is clear that the two workshops collaborated and that the client was able to order a Malines doll with either a Brussels polychromy (particularly for the applied brocades), or a Malines polychromy (marked by an M punched into the gilding, generally in the middle of the figure's gilded garment). From the beginning, the characteristics of Malines polychromy were painted decorations on burnished and punched gold: flowers, foliage, and strawberries on the borders of the garments and on the base. A little later, the polychromy was often decorated, as at Antwerp, with motifs in sgraffito<sup>17</sup> on gold—and especially on burnished silver—and the sculptural quality began to diminish. Finally, personal marks of the Mechlin polychromists—monograms struck into the gilding of the base—have been found on several examples (Van Doorslaer 1933).

To further complicate the situation, an altarpiece very similar in construction to that of Odeby, which has a case with brackets, is consequently considered as Mechlin in origin, but it possesses an Antwerp mark on its case (Nieuwdorp 1993). Could it have been polychromed or finished in Antwerp?

The production, commerce, and exportation of the Malines dolls during the first quarter of the sixteenth century assumed a proportion difficult to imagine. In effect, they are found in all European countries: Portugal (Ferraio de Tavares e Tavora 1976), Spain (Eguia Lopez de Sabando 1983; Mirari 1989), abundantly in France and Germany, and as far as the Philippines, where one was given as a present to the queen of Mazzava from the Portuguese navigator Magellan (Didier 1973). The production of the Malines dolls cannot be counted by the dozen but rather by the hundreds.

The dolls were also acquired by the devout of the region's convents, who surrounded the figures with flower embroideries in the celebrated closed gardens of Mechlin (Vandenbroeck 1993:91–104). These gardens were appointed with relics, ex-votos, and Malines dolls until the beginning of the seventeenth century. At the end of the century, the azurite blue of the dolls was replaced by smalt. Occasionally, the nude Infant Jesus was dressed, but this became obligatory only after the Council of Trent (1545–63). The Infant Jesus from Lubeck is an extraordinary example (Hasse 1970:160–61). The high demand by collectors and dealers for these dolls has led to the production of numerous fakes.

---

## The Antwerp Workshops

Antwerp produced altarpieces at the end of the fifteenth century, though the major part of its production occurred after 1500. (Marks became mandatory around 1471–72). It could be said that Antwerp surpassed Brussels at that point in terms of reputation and that Brussels artisans probably came to practice at the Antwerp guild. The works were constructed more rapidly, and the compartments were more numerous and tiered—most altarpieces having six compartments. The early, generally rectangular, forms took on arcing shapes, and the altarpieces were then placed on a painted or sculpted predella.

Antwerp altarpieces were the subject of special study and conservation for the 1993 exhibition at Antwerp Cathedral. Systematic dendrochronological analyses have confirmed that the oak used always came from the Baltic region and was imported to Antwerp by boat.<sup>18</sup> The wood bears the marks of a type of scraper, a marking tool of the woodcutter (Glatigny 1993; Serck-Dewaide 1993b).<sup>19</sup> The guild required the use of aged, quartersawn oak, from which the sapwood was eliminated. Despite these strict rules, a few millimeters of sapwood is often found on at least one sculpted piece from each altarpiece, thus permitting a correct dating. The assemblages of the case were always made with dovetails and mortise and tenons. The planks at the back were left split and were nailed to the framing structure.

The architectural elements were constructed according to a typical scheme. The theater of historical scenes is presented on an incline plane, as if staged. Four or five figures are generally positioned in the foreground plane, occasionally with their backs to the spectator while observing the scene in the middle or background planes. The gilded concave architectural elements frame the space in the middle ground, which contains the principal scene. In the background plane, landscapes, architectural elements, or secondary scenes are fixed to the half hexagon-shaped canopy of the architecture.

During the numerous restorations, observation of the various marks has allowed a chronology of the work to be established. Altarpieces were mounted three times. The first mounting was in bare wood, when the preliminary adjustments were made; any possible imperfections—pieces too high or too low—were corrected by adding blocks to the bases or at the backs of the fragments.

The work of the sculptor was controlled; and, before application of the ground layer, numerous statuettes were marked by hot iron with the “hand” of Antwerp on the head or on the base. The elements were then given a ground layer according to the same method used in Brussels or Mechlin, except that the manner in which the pieces were secured during the application of the ground was different. Square nail holes, systematically placed at the middle of the back, hold no significance for the attachment of the altarpiece. This implies that a plank was nailed to the back, on which the individual pieces were posted for application of the ground layers. In this way, handling the fragments would not be necessary, yet the edges of the back of each piece could still be reached.

After the ground was recut and smoothed, one layer of orange-colored bole was applied, and the altarpiece was mounted a second time. The hidden parts of the pieces that were not intended to receive gilding were delineated by incisions. Adjustments that were made after the ground was applied (indicated by marks in the ground layer) can be seen at the back. Each element of the statuette then received the desired gold or silver gilding. After guilders burnished the water-gilded metallic leaves, produced decoration by punching, and matted the gold with a protective layer of glue, painters proceeded to apply the underpaint and the paint layers in tempera—for example, black or medium blue under the azurite, and pink in an aqueous medium for the flesh tones (Sanyova 1993).

Oil gilding was generally applied on an oil layer, to which ochre was added. Often, analyses and visual observation reveal a red layer of

minium under the oil layer. This can be interpreted as an isolating layer or a layer that would indicate to the gilder the positioning for the matte gold.

Oil colors, glazes, and decorations followed. The precise succession of operations, particularly for flesh tones, is discernible by examining how the layers correspond at the juncture of two colors. Thus, between the flesh tones and the oil-gilded hair, the preliminary application of a pink underlayer can be distinguished, followed by layers of matte gold (underlayer, oil layer, gold). Finally, the pink layer, made with an oil medium, was applied to color the cheeks; then the eyelashes, eyebrows, eyes, and mouth were painted when this layer was dry. The decorations were created through the use of different techniques; punching performed by the gilder has already been mentioned, although painted decorations of flowers, leaves, lettering, and geometric lines are found with equal frequency on the gilding.

Finally, the characteristic technique of the Antwerp school is sgraffito. This technique consists of applying a paint layer on a burnished gold or silver surface and, after a moment of drying, of engraving into the colored layer to allow the gold or silver to show through it. This rapid technique replaced the applied brocade technique used by the Brussels workshops. A very few local and other rare examples of brocades (perhaps done by Brussels artisans?) are found on Antwerp altarpieces from the beginning of the sixteenth century—for example, on the altarpiece from the church of 's Hertogenbosch in Holland (Smedt 1993:52–57).

The altarpiece was then mounted a third time. Certain adjustments can still be seen. Everything was fixed with the help of forged nails inserted into the prepared holes of the first schemes. At this stage, gilders and painters intervened again. They applied the final touches to the altarpieces in their vertical position. The heads of visible nails were oil gilded, and the decoration of the tile pavement was finished, as was the shading, with a green glaze, the drip marks of which are visible at the back. When the ensemble was completely finished, the mark of the castle and two hands was burned into the side of the case or, occasionally, on the frame of the paintings.

This veritable “art industry” led to a rather stereotypical production. The garments, the architectural decorations, and the stance of the figures evolved slowly toward Mannerism and the Renaissance. The palette and the mixture or the superimposition of pigments changed slowly, but the structure and organization of the work seems to have remained unchanged until around 1570, by which time altarpieces of this type were no longer ordered.

---

## Material Evolution of the Altarpieces

Within the group of preserved altarpieces—including 180 from Antwerp, catalogued by Hans Nieuwdorp; approximately 70 from Brussels; and hundreds, or perhaps a thousand, Malines dolls (not counting the fragments from dismantled altarpieces)—it could be said that rarely have works survived in their original, pristine state. The works have been subjected to natural aging, iconoclasm, vandalism, theft, and church fires, as well as cleanings, overpaintings, retouchings, varnishings, replacement of elements, and other poor interventions. The state of conservation varies according to the regional school (Brussels, Mechlin, or Antwerp) and according to the country in which the works are preserved. Unfortunately,

as a result of successive restorations, a series of the most beautiful extant Brussels altarpieces in Belgium was stripped during the second half of the nineteenth century. These include the following altarpieces: the Virgin from the church of Lombeek-Notre-Dame in Brabant (De Borchgrave d'Altena 1938; Wauters 1971:170–88); Saint Crispin and Saint Crispinian, attributed to Jan and Pasquier Borman, from the church of Herenthals, Antwerp (Kuyt 1870; D'Hainaut-Zveny 1983); the altarpiece in the church of the Saints, Brabant; the altarpiece from the church of Hemelverdegem, western Flanders; the two from the parish church of Villers-la-Ville, Brabant; and finally, the altarpiece of Saint George in the *Musées Royaux d'Art et d'Histoire*.

By contrast, the thirty-three Brabantine altarpieces in Sweden survive in relatively good condition. None of them have been stripped; they have only been overpainted (a common practice), but the quality of the overpaints is quite acceptable.

It could also be said that half of the altarpieces produced at Mechlin have been stripped, or otherwise “mistreated” (the statuettes overpainted, poorly restored, scraped, altered, etc.).

Of the twenty altarpieces (or parts of altarpieces) that were chosen for exhibition in Antwerp in 1993 because of their “good state of preservation,” five have original polychromy. Those from Valladolid, Spain, and Thenay, France, have no recent intervention. After recent treatment for exhibition, those from Dijon, France; Elmpt, Germany; and Arlon in the province of Luxembourg, Belgium, now have original polychromy. Three more have original polychromy following removal of overpaints: those from Lanaken in the province of Limburg, Belgium; Bouvignes in Namur, Belgium; and 's Hertogenbosch, Holland. Finally, among the remaining twelve, the altarpiece from Netterden, Holland, has been stripped to the wood, and obvious repairs to the eleven others include overpaints and pervasive varnishing, which either partially or totally mask their original aspect, often altering it completely.

Of the twenty-one exposed fragments, nine are stripped to the wood, ten have original polychromy—either in good condition, damaged (dirty, with lifting polychromy), or poorly restored—and two have a very beautiful Spanish Baroque overpaint.

Statistically, the situation would appear to be consistent with what is generally found elsewhere.

---

## Treatments

Treatments that should be performed by conservators obviously differ in each case and according to the state of preservation of the work. The minimal amount of intervention possible is the best approach for an altarpiece, provided that it is at least preserved in a stable environment and that it does not travel. To study and understand these works, it is necessary to examine those works that appear to be in the most pristine condition and to intervene as little as possible.

For this reason, the following altarpieces have been chosen for discussion: the Brussels altarpiece from Saluzzo; the Mechlin altarpiece with Brussels polychromy from the *Musée Mayer van den Bergh*; the Mechlin Virgin and Child with Malines polychromy from the *Musée d'Audenarde*; and the Oplinter altarpiece from the *Musées Royaux d'Art et d'Histoire*. These works are particularly intact; they display only a few early, localized

interventions, and the conservation treatments carried out during the last two decades have been minimal. For the altarpieces from Bouvignes, Namur, and Opitter, Limburg, detailed interdisciplinary studies have permitted an understanding of the numerous interventions and have influenced the approach to their complex treatments.

### The Brussels altarpiece from Saluzzo

The Saluzzo altarpiece depicts the life of the Virgin and Saint Joseph (Fig. 1). It is dated around 1500 and is attributed to the workshop of Pasquier Borman, son of Jan. The painted wings are attributed to Valentin Van Orley (Coo 1979). The altarpiece was commissioned by the Roman family Pensa di Mondovi and installed in the north of Italy. It was bought by the city of Brussels in 1894 and exhibited in the Musée Communal de la Maison du Roi. The exceptionally well-preserved polychromy may be considered original; only a few of the faces seem to have been locally inpainted.

In 1988, at the time of alterations at the museum, the Institut Royal du Patrimoine Artistique (IRPA) was charged with a “renewed maintenance” before presentation of the work in a new exhibition case. Records indicate that identical maintenance was carried out in 1950 and 1973. It took eight days for a team of five conservators to carry out the treatment, which was undertaken in situ without dismantling the altarpiece. A few lifting areas of the polychromy were set down with a wax-resin mixture for the burnished gold and sturgeon glue for the matte colors and the brocades. Dust was removed with small sable brushes. For a few dirtier areas, white spirit and toluene were used. Respect for the original “matting” layer placed on the burnished gold was considered very important, and the encrusted patina on this layer was not removed. A few pinpoint retouchings along the edges of the losses were done with watercolor.

### The Mechlin altarpiece from the Musée Mayer van den Bergh

This altarpiece, dated around 1500, has three figures: Saint Catherine, the Virgin and Child, and Saint Barbara (Fig. 5). The interior wings are decorated with images of Saint Madeleine and Saint Agnes. The closed wings present two small angels elevating ribbons and coats of arms on a marbled green-and-black background. The altarpiece had been overpainted, the exterior wings being entirely overpainted in black. A coat of arms above the two saints on the wings was painted on the sky, then hidden by an overpaint imitating the sky. The case, architectural elements, and bases were rather heavily regilded. The blue of the figures has been overpainted, and their faces have been overpainted twice. Two crowns are original; that of the Virgin is a later addition.

The oak case has a Malines mark on its left side, and the three walnut statuettes have the same mark on their bases. The polychromy is identical to that of the Saluzzo altarpiece and appears, therefore, to be of Brussels production. The BREUSEL mark, generally affixed on the socles, must have been lost at the time of the regilding. Moreover, it seems that the painting of the wings was also carried out by the Brussels workshops.

A complete treatment was carried out at IRPA in 1970. It consisted of setting down the lifting polychromy with wax resin for the gilding and with dilute poly(vinyl acetate) for the blue layers and decorations.



Figure 5

Mechlin altarpiece with a Brussels polychromy, ca. 1500. In the collection of the Musée Mayer van den Bergh, Antwerp.



Figure 6

Mechlin Virgin and Child with a Malines polychromy, ca. 1520–1530. Hotel de Ville, Audenarde (eastern Flanders).

The localized overpaints on the dolls had been removed, as well as the overpaint on the exterior wings. Campaigns of maintenance were executed in situ in 1978 and 1985.

### Mechlin Virgin and Child from the Town Hall at Audenarde

This sculpture (Fig. 6) (Serck-Dewaide 1995) presents a typical Malines polychromy. The figure is in walnut and the base is in oak. It could be dated around 1520–30 and, interestingly, possesses four different marks. On the back of the figure is a mark of the Mechlin workshop—a shield with three pales; on the socle is a shield and wheel with eight spokes, an individual mark of the sculptor (the same mark as found on a Saint Peter in the Musées Royaux d'Art et d'Histoire, Brussels). On the gold of the garment in the front is an M—the mark of the polychrome workshop of Mechlin—and an individual mark on the base, a square punch with an anchor and two rather indecipherable letters (J and E, or I and S?).

A treatment was carried out at IRPA in 1963, consisting of disinfection, a very localized consolidation of the worm-eaten wood, and setting down of the polychromy with wax and poly(vinyl acetate). In 1994, maintenance of the sculpture collection was requested by the Town Hall. Another setting down of the polychromy was necessary (using wax resin and sturgeon glue). New, small losses were apparent in the polychromy. A few retouchings were made using dry pigments and Acryloid B72 in ethanol to which a little diacetone alcohol was added.

### The Antwerp altarpiece from Oplinter

The altarpiece of the Passion from Oplinter, circa 1530 (Figs. 7 and 8a, b), has been in the collection of the Musées Royaux d'Art et d'Histoire since 1894. Except for the addition of two angels positioned back to back at the

Figure 7

Antwerp altarpiece from Oplinter. In the collection of the Musées Royaux d'Art et d'Histoire, Brussels.

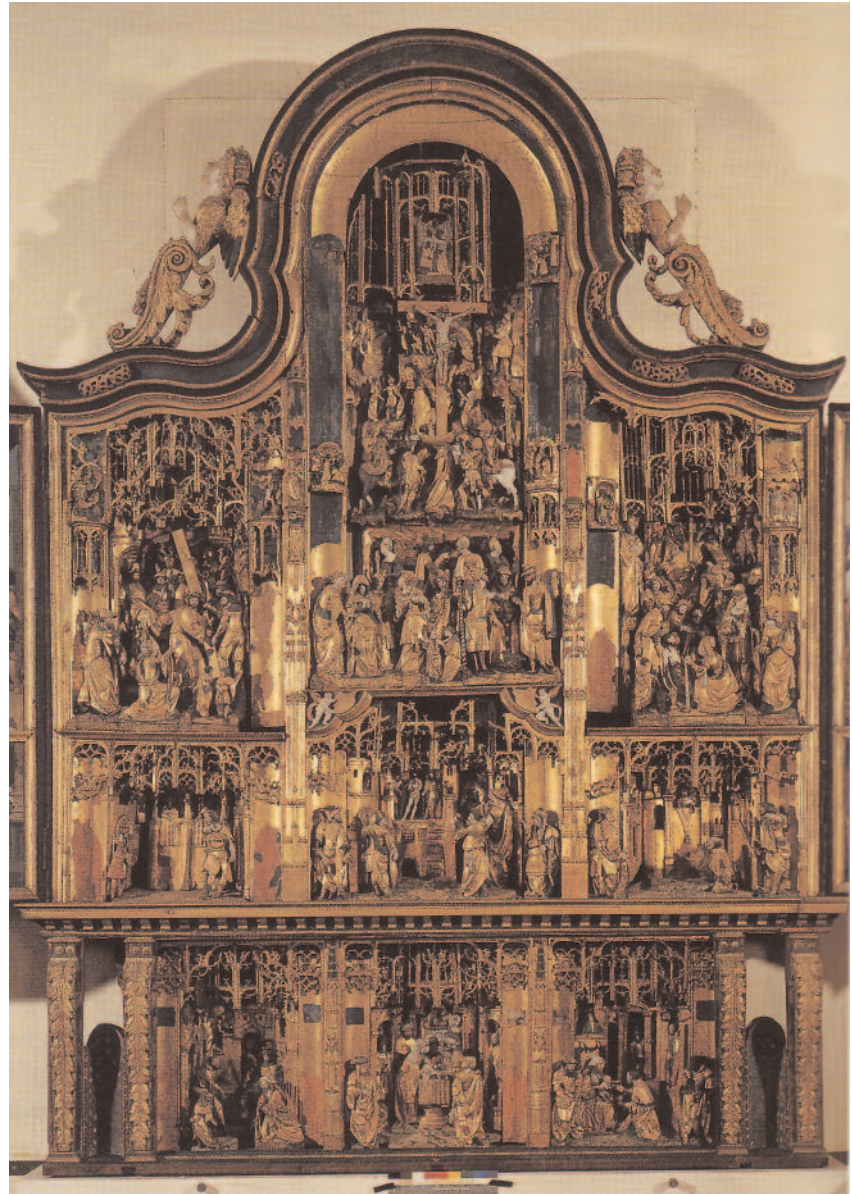

a



b

Figure 8a, b

Detail of the Magus, front and back, from the Antwerp altarpiece from Oplinter. Note the added block and nails, the scraper marks, the inscription, and the punch marks.

top of the hutch, four pilasters, two niches, a seventeenth-century cornice framing the predella, and the unfortunate theft of nineteen fragments, the altarpiece is remarkably intact. Almost all the surfaces remain untouched since its creation, although a resinous varnish, applied to the flesh tones, has strongly altered their legibility.

While certain fragments were dismantled during transport to the museum, the architectural elements and all of the third plan were never dismantled. The observations made at the time of the restoration performed at IRPA during 1972–74 were particularly fruitful and are noted in the Antwerp catalogue (Serck-Dewaide 1971–72).

Treatment consisted of setting down the polychromy before transport to IRPA, dismantling, another setting down of the polychromy, laboratory examination, balanced cleaning, removal of the varnish, inpainting,

remounting, and documentation. Recently, a survey of the archival material and a study of the iconography were undertaken (De Boodt 1993), and a complete, multidisciplinary publication is in preparation. Maintenance provided the opportunity to sample the various layers for analysis.

Selection of the works presented here has been guided by the state of conservation of their polychromy. It should be added that more extensive treatments also have been carried out. For example, overpaints were removed from the Antwerp Renaissance altarpiece of the Passion from the church of Bouvignes (province of Namur), which dates to around 1556, and a new hutch was added (Serck-Dewaide 1993a; Bauret and Serck-Dewaide 1993). Another altarpiece, one of the Passion from the church of Opitter (province of Limburg), had such a complex history of interventions that it took fifteen people one year to complete its examination and treatment. It is hoped that a comprehensive study on this subject will be published.

---

## Conclusion

It should be pointed out again that the quality of the cut of the wood and the perfection brought to bear on the polychromy are guarantees of the excellent state of preservation of Brabantine altarpieces, provided that the works have not been subjected to vandalism, severe climatic fluctuations, or poor restorations.

Consequently, preventive conservation is essential, so as not to allow an altarpiece to become overly dirty, and a system of regular maintenance is advised. It is obvious that protection was better in the past, as the wings were almost always closed. Today, cases and alarms are necessary in the churches and museums that house the altarpieces.

The life of each of these altarpieces is very complex, and it is not easy for the uninformed spectator to recognize or differentiate between the specific and original features of polychromies from Brussels, Mechlin, and Antwerp. It is therefore necessary to publish, in color, the intact evidence, and to make art and conservation professionals aware of the history of these altarpieces and of polychromy techniques. This was an aim of the Colonial Williamsburg symposium, and it is the aim of this article.

---

## Notes

- 1 A *tabernacle* is a small structure situated in the middle of an altar, containing the holy sacrament.
- 2 A *baldachin* is an architectural element in wood, marble, or metal that crowns an altar or a sculpted scene.
- 3 This area today is divided between Belgium (the provinces of Antwerp and Brabant) and the Netherlands (province of North Brabant). In the fifteenth century, the large Brabantine cities—Brussels, Louvain, Mechlin, and Antwerp—profited from the decline of the Flemish cities of Bruges and Ghent and became the centers of political, administrative, industrial, and artistic activity for the former Netherlands.
- 4 *Hutch maker* is a medieval term designating a cabinetmaker and maker of coffers, cupboards, and altarpiece cases.
- 5 *Hutch* generally refers to a coffer or furniture element in wood; it is also the term used for the case of an altarpiece.
- 6 The letter J was discovered on the oldest altarpiece (the Nativity) from the church of Villers-la-Ville, dated ca. 1460, during restoration at the Institut Royal du Patrimoine Artistique (file # 2L/31-81/2315). This letter, struck seven times on the back of the altarpiece, is also found on the case of a Brussels altarpiece in Berlin, a photograph of which was published

by Demmler (1930:344). Other personal marks include the one drawn by Nahuys Maurin (1879:17–24) and the flower visible on the case of the Nativity altarpiece from the Maison du Roi, a work very close to that in Berlin.

- 7 Such marks are found on the architectural elements of Brussels altarpieces. In the case of the Villers-la-Ville altarpiece, one can see marks of the curved chisel: “(, ((, (((, (((((”); the flat chisel: “/, //, ///, ////”); or the round punch: “., .., ..., ....., Y, Y,” with a notation system similar to Roman numerals. Each case or compartment has a code defined by a different tool. Despite the stripping of the polychromy and the dismantling to which these altarpieces have been subjected, these marks appear to be original. For the Vermeersh altarpiece in the collection of the Musées Royaux d’Art et d’Histoire (MRAH), the marks found under the colonnettes are “I, II, III,” and are original as indicated by the appearance of ground and gold under the edges. For the stripped altarpiece of Lombeek-Notre-Dame, the marks cannot, with certitude, be construed as original, but the same type of mark with Roman numerals appears. The same mark is found on the architectural elements of the altarpiece of Claude de Villa and Gentile Solaro (MRAH).
- 8 These woodcutter’s marks have been confused with the marks intended to denote position (see Verougstraete and van Schoute 1993).
- 9 A *ground* is the first layer applied to wood before painting. Gesso, which is always composed of calcium sulfate, is used as a ground in the southern countries: Italy, Spain, south of France. However, in the north—Northern France, Belgium, Holland, Germany, and the Baltic countries—calcium carbonate is used. Therefore, the term *gesso* is not used in this article. (The confusion between these terms continues in the English literature.)
- 10 *Applied brocade* is a polychrome technique imitating, in relief, a brocaded and gilded textile.
- 11 These “cups” are seen as part of the polychromy of the altarpiece of the “Vermeersch Bequest” Passion, and on the recently acquired altarpiece of the Passion, both in the collection of the Musées Royaux d’Art et d’Histoire, and on the altarpiece of Saint Dymphne from the church at Geel.
- 12 *Tremolierungen*, a German word with no precise English or French translation, refers to relief designs carved in wood with a curved gouge.
- 13 Throughout the literature, Mechlin (the English spelling used here) may be more often encountered in its French spelling, *Malines*, particularly in regard to this town’s artistic production. The French spelling is reserved here for references to the well-known Malines dolls and their polychromy.
- 14 Willy Godenne published a series of pieces on the Malines dolls in his *Handelingen van de Koninklijke Kring voor Oudheidkunde, Letteren en Kunst van Mechelen*. This series, titled “Préliminaires à l’inventaire général des statuettes d’origine malinoise présumées des XVème et XVIème siècles,” ran from 1957 to 1976 and appeared in the following volumes: 61:47–127; 62; 64; 67:68–156; 73:43–86; 76(2):3–80; 77(1):87–146; 78:93–104; 79:133–39; 80(1):71–105. The series was also published in French in *Bulletin du Cercle royal archéologique, littéraire et artistique de Malines* (Brussels).
- 15 A *canopy* may be defined as a small vault decorated with an ornamental arcade and pinnacles, screening the sculptures of a portal. (For altarpieces, the canopy and baldachin are used in an identical manner.)
- 16 As on the altarpiece with three dolls from the Loze-Corswaremme collection (see Derveaux-Van Ussel 1973b).
- 17 *Sgraffito* is a polychrome technique consisting of the application of a paint layer on top of burnished gold or silver, followed by the creation of motifs by selectively removing the paint layer.
- 18 See Vynckier 1993:189–91 for an explanatory note concerning the dendrochronological examination of several Antwerp altarpieces from the fifteenth and sixteenth centuries. It is likely that the Brussels workshops also used oak from the Baltic region, but a systematic dendrochronological analysis of Brussels altarpieces has not been carried out.
- 19 The French term for this tool is *rainette*.

---

**References**

- Ballestrem, Agnès**  
1968 Un témoin de la conception polychrome des retables bruxellois au début du XVIème siècle. *Bulletin de l'Institut Royal du Patrimoine Artistique* 10:36–45.
- Bauret, C., and M. Serck-Dewaide**  
1993 *Le retable de la vraie croix (vers 1556)*. Brussels: Foundation Roi Baudouin.
- Coo, Josef de**  
1969 *Museum Mayer van den Bergh. Catalogus 2. Beeldhouwkunst, plaketten, antiek*. No. 2256/2258. Anvers. 202–3.
- 1979 Twee Orley-retabels. *Jaarboek van het Koninklijk Museum voor Schone Kunsten-Antwerpen*, 67–104.
- De Boodt, Ria**  
1993 Het passieretabel van Oplinter in de Koninklijke Musea voor Kunst un Geschiedenis te Brussel. Report, University V.U.B., Brussels.
- De Borchgrave d'Altena, Joseph**  
1938 Le retable de Lombeek. *Annuaire des Musées Royaux des Beaux-Arts de Belgique* 1:73–87.
- Demmler, T.**  
1930 Je Bildeworke in Holz, Stein und Ton. In *Die Bildwerke des Deutsches Museums*, vol. 3. Berlin-Leipzig: W. De Gruyter.
- Derveaux-Van Ussel, G.**  
1973a Een Mechels Aanbiddingsretabel in het Suermondt-Museum te Aken. *Aachener Kunstblätter* 44:233–44.
- 1973b *Le retable malinois de l'église d'Odeby*. Artes Belgicae. Brussels: Musées Royaux d'Art et d'Histoire.
- D'Hainaut-Zveny, Brigitte**  
1983 La dynastie Borreman (XVe–VXIe s.): Crayon généalogique et analyse comparative des personnalités artistiques. *Annales d'Histoire de l'Art et d'Archéologie* 5:47–66.
- Didier, Robert**  
1973 L'enfant Jesus présumé malinois de Cebu (archipelago of Visaya, Philippines). *Handelingen van de Koninklijke Kring voor Oudheidkunde, Letteren en Kunst van Mechelen*, 147–55.
- Eguia Lopez de Sabando, J.**  
1983 Imagines de malinas en Alava. *Rev. Kultura* 5:24–32.
- Ferrao de Tavares e Tavora, Bernardo**  
1976 Twenty Malines dolls, now in Lisbon. In *Imagens de Malines: Coleção Museu Nacional de Arte antiga*. Exhibition catalogue. Lisbon: Museu Nacional de Arte antiga.
- Fichefet, M. L.**  
1965 Le retable de Saluces, trésor du Musée Communal de la ville de Bruxelles. *Credit Communal Belgique: Bulletin trimestriel* 72:83–96.
- Glatigny, Jean-Albert**  
1993 Des marques énigmatiques. In *Antwerpse retabels 15de–16de eeuw*. Vol. 2, 142–43. Antwerp: Museum voor Religieuze Kunst.
- Godenne, Willy**  
1972 Préliminaires à l'inventaire général des statuettes d'origine malinoise présumées des XVème et XVIème siècles. *Handelingen van de Koninklijke Kring voor Oudheidkunde, Letteren en Kunst van Mechelen* 76(2):3–80.

- Hasse, Max  
1970 *Lübeck, Sankt Annen-Museum: Die Sakralen Werke*. Lübeck, Germany: Deutscher Kunstverlag.
- Jacobs, Lynn F.  
1989 The marketing and standardization of South Netherlandish carved altarpieces: Limits on the role of the patron. *The Art Bulletin* 71(2):208–29.
- Koller, Manfred  
1995 Studien zur gefassten Skulptur des Mittelalters in Österreich: Der Flügelaltar aus Mecheln in der Deutschordenskirche zu Wein, in, *Österreichische Zeitschrift für Kunst und Denkmalpflege*. Report, Vienna.
- Kuyl, M. P. D.  
1870 Retable de l'ancienne corporation des tanneurs dans l'église paroissiale de Sainte Waudru à Herenthals. *Annales de l'Académie d'Archéologie de Belgique* 26:267–76.
- Maurin, Nahuys  
1879 Retable d'autel avec sculptures et peintures. *Annales de l'Académie d'Archéologie de Belgique* 35:17–24.
- Mirari  
1989 *Catálogo de la exposición: Diciembre 1989–enero 1990*, 213–30. Exhibition catalogue. Vitoria, Spain: Diputación Foral de Alava.
- Nieuwdorp, Hans  
1981 De oorspronkelijke betekenis en interpretatie van de keumerken op Brabantse retabels en beeldsnijwerk. In *Archivum Artis Lovaniense: Bijdragen tot de geschiedenis van de Kunst der Nederlanden*. Vol. 7, 85–98. Louvain, Belgium: Uitgeverij Peeter.
- 1993 *Antwerpse retabels 15de–16de eeuw*. Vol. 1, 15–24. Antwerp: Museum voor Religieuze Kunst.
- Sanyova, Janka  
1993 Etude scientifique des techniques picturales des retables anversois. In *Antwerpse retabels 15de–16de eeuw*. Vol. 2, 151–64. Antwerp: Museum voor Religieuze Kunst.
- Serck-Dewaide, Myriam  
1971–72 Retable d'Oplinter: Rapport de restauration. Report. File, IRPA. 2L/47–71/168.
- 1990 Relief decoration on sculptures and paintings from the thirteenth to sixteenth century: Technology and treatment. In *Cleaning, Retouching and Coatings: Preprints of the Contributions to the Brussels Congress, 3–7 September 1990*, ed. J. S. Mills and P. Smith, 36–40. London: International Institute for Conservation of Historic and Artistic Works.
- 1991 The history and conservation of the surface coating on European gilded wooden objects. In *Gilded Wood: Conservation and History*, ed. D. Bigelow, 65–78. Madison, Conn.: Sound View Press.
- 1993a Examen et restauration de huit retables anversois. In *Antwerpse retabels 15de–16de eeuw*. Vol. 2, 129–41. Antwerp: Museum voor Religieuze Kunst.
- 1993b Les retables anversois sous le regard de restaurateurs. In *Antwerpse retabels 15de–16de eeuw*. Vol. 2, 114–28. Antwerp: Museum voor Religieuze Kunst.
- 1995 La Vierge à l'enfant (no. 23). In *Dorure, brocarts et glacis: S.O.S. Polychromies (catalogue d'exposition, 27 octobre–31 décembre 1995, Musée des arts anciens du Namurois—Namur)*, 109–10. Exhibition catalogue. Brussels: Fondation roi Baudouin.

- Skubiszewski, Piotr  
1989 Le retable gothique sculpté entre le dogme et l'univers humain. In *Le retable d'Issenheim et la sculpture au nord des Alpes à la fin du Moyen-Age*, ed. C. Heck Colmar, 13–47. Colmar, France: Musée d'Unterlinden.
- Smedt, Herman J. de  
1993 *Lübeck, Sankt Annen*. Vol. 1, 52–57. Exhibition catalogue no. 7. Lübeck.
- Van Doorslaer, G.  
1933 Marques de sculpteurs et de polychromeurs malinois. *Revue Belge d'Archéologie et d'Histoire de l'Art* 3:159–76.
- Vandenbroeck, Paul  
1993 *Le jardin clos de l'âme: L'imaginaire des religieuses dans les Pays-Bas du Sud, depuis le 13ème siècle*. Brussels: Martial et Saeck.
- Verougstraete, H. M., and R. A. van Schoute  
1993 Retables sculptés et volets peints: Examen de la menuiserie, des profils et de la polychromie des cadres du retable d'Herbais sous Piétrain. In *ICOM Committee for Conservation 10th Triennial Meeting, Washington D.C., USA, 22–27 August 1993, Preprints*. Vol. 2, 693–96. Paris: ICOM Committee for Conservation.
- Vynckier, Jozef  
1993 *Antwerpse retabels 15de–16de eeuw*. Vol. 1. Antwerp: Museum voor Religieuze Kunst.
- Wauters, A.  
1971 *Histoire des environs de Bruxelles et description historique de localités qui formaient autrefois l'amani de cette ville*. Vol. 2. 1855. Reprint, Brussels: Editions Culture et Civilisation.

# Painted Italian Picture Frames in the Samuel H. Kress Foundation Collection at the National Gallery of Art

Nancie C. Ravenel

**I**N THE LATE 1940s, as the Samuel H. Kress Foundation began to distribute works of art to museums all over the United States, it also continued to expand its collection. In addition to purchasing paintings and sculptures, the foundation acquired approximately eight hundred antique picture frames, many of which were restored at the foundation's conservation facility in Pennsylvania for use on Kress Collection works of art (Perry 1994). Other frames without paintings were given to museums to be used as they saw fit. Two hundred frames were donated to the National Gallery of Art in 1961. Each had been labeled by the foundation with a number, an attribution, and the dimensions of the frame's rabbet. The frames are identified as being of Italian, French, Flemish, and Spanish origin, dating from the fifteenth to eighteenth century, with the majority of the collection being Italian, from the sixteenth and seventeenth centuries. These are primarily *cassette* and reverse profile frames, but there are also a few *tabernacles* and *tondi*.<sup>1</sup>

The Kress Foundation archive indicates that in the 1940s nearly five hundred frames were purchased from Alessandro Contini-Bonacossi, an Italian art dealer (Perry 1994:27), who stated in a letter to Rush Kress, the foundation's president at the time, "I have dedicated myself to buying up the few good frames that have turned up" (Bowron 1994:48). In fact, the collection that Contini-Bonacossi sold to the Kress Foundation is an amalgamation of smaller frame collections.<sup>2</sup> One smaller collection has been identified through markings on the reverse of the frames.

It is noteworthy that although most of these frames were acquired by the Kress Foundation without paintings, others were deemed of higher importance than the paintings they contained and were removed from those paintings by the foundation (Modestini 1994). Much of what is known about the provenance and history of picture frames is directly related to their contextual relationship with paintings, and without the provenance, dating and attribution of frames is conjectural. For some frames in the collection, the relationship between frame and painting has been reestablished through examination of 1930s photographs of Samuel Kress's New York City apartment, in which frames now at the National Gallery appear on paintings currently housed in other museums. The labels from previous collections have also helped in linking frame to painting.

Although most of the frames donated by the Kress Foundation are water gilded, approximately one-quarter are painted. They can be divided



into three types of decoration: Some are painted to imitate other materials, such as tortoiseshell or exotic woods, or to suggest a carved relief; others are painted a solid color and decorated with mordant gilding; the third group is decorated with sgraffito, a technique in which paint is applied to a water-gilded surface and then mechanically removed in a decorative pattern that reveals the gilding beneath.

---

## The Technical Study

In conjunction with the preparation of an inventory and condition survey of the frames at the National Gallery of Art, the Frame Conservation Department has begun a study of the techniques and materials used on period frames. Traditionally, frame attributions are made through analysis of the combination of decorative motifs and the type of frame. Because style and decoration are copied from region to region and span several centuries, a technical study of materials used in the fabrication of the frame complements connoisseurship to provide a fuller picture of a frame's origin. While gilding techniques and materials have remained fairly consistent, painting materials and their manner of application have changed over the centuries. Therefore, this technical study has begun with the more complex, but perhaps easier to date, painted frames.

For the pilot project, four *cassette* with blue-painted sgraffito friezes attributed stylistically to sixteenth-century Venice were chosen. Selected for the study primarily because their surfaces appear to have incurred little or no intervention, they are not consistent in terms of quality, sophistication of construction, or decoration.

---

## Frame Descriptions

Frame 0321 (Fig. 1) is constructed of a softwood. Its joinery, a mitered half dovetail lap, is unusual but has also been seen on several *cassette* decorated with molded *pastiglia*,<sup>3</sup> also attributed to sixteenth-century Venice and on view at the National Gallery. Written in ink on the reverse of the frame are the initials "C. T.," which may relate to the frame's maker, to a prior owner of the frame, or to the identity of a painting it once housed. Typical of *cassette* and common to the four frames in this study, the sight and outer moldings are separate pieces of wood nailed to the back frame (Fig. 2). The frieze is punched in a lattice pattern and decorated with sgraffito. The painted areas appear to have been laid out in advance with incised lines

Figure 1a, b

Front (a) and back (b) of a *cassette* frame. Venice, sixteenth century. Polychromed and gilded wood. 53.3 × 48.3 cm. Samuel H. Kress Foundation Collection, National Gallery of Art, frame 0321.

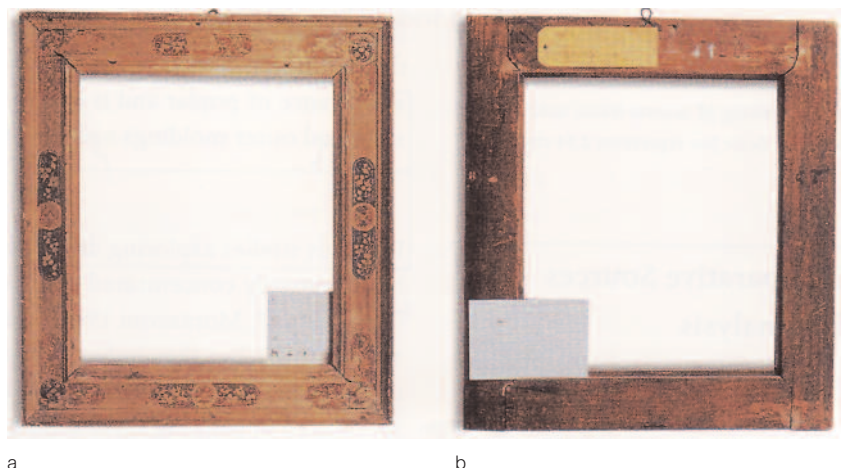

a

b

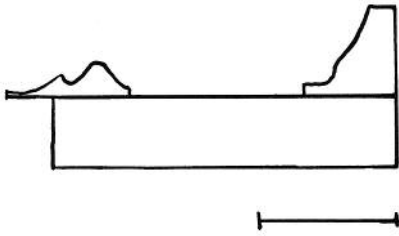

Figure 2  
Profile drawing of *cassetta* frame 0321 (shown in Fig. 1). Scale bar represents 2.54 cm.

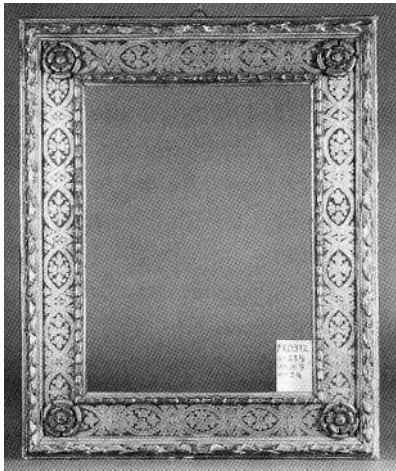

Figure 3  
*Cassetta* frame. Venice, sixteenth century. Polychromed and gilded wood. 93.0 × 75.9 cm. Samuel H. Kress Foundation Collection, National Gallery of Art, frame 0392.

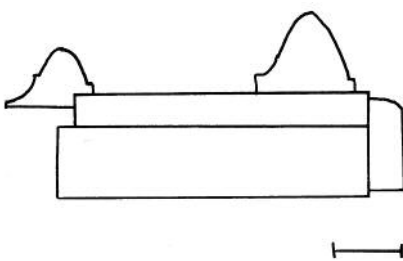

Figure 4  
Profile drawing of *cassetta* frame 0392 (shown in Fig. 3). Scale bar represents 2.54 cm.

drawn first with a compass. These areas were filled in with a fine, transparent red paint, then a coarse, opaque blue-green paint, prior to having a scrolling foliate design scraped out of the paint. The frame does not appear to have undergone any restoration and is in very worn condition. There is a similar type of punched and painted decoration on the outer molding of a mirror frame dating from the early sixteenth century in the collection of the Palazzo van Axel in Venice (Morazzoni 1944:37) and on an early-sixteenth-century Venetian *cassetta* in the Robert Lehman Collection at the Metropolitan Museum of Art (Newbery and Kanter 1990:88).

Structurally, frame 0392 (Fig. 3) may be a pastiche, but it is constructed of hardwoods that all have the appearance of poplar (*Populus*). The sgraffito painted frieze is on mitered pieces of wood that are nailed to the half-lap jointed back frame (Fig. 4). This type of construction is unusual for painted *cassetta*. It appears that the sight and outer moldings were prepared for gilding separately from the frieze. The applied sight and outer moldings are carved with imbricated leaves, and there is a turned rosette glued and nailed in each corner of the fascia. The frieze is decorated with a floral and strapwork sgraffito design with a thinly painted, dark blue background. The edges of the design are punched with a dome-shaped tool. When viewing the frieze below the rosettes (Fig. 5), it appears that the sgraffito was executed without regard to the rosettes. In these areas, paint, gold leaf, and bole appear to have been removed, leaving remnants of gold in the bottoms of the punch marks. The frieze seems to have had no other alteration.

Frame 0393 (Fig. 6) is constructed of a hardwood that exhibits the characteristics of poplar, with bridle joints and mitered moldings nailed to the back frame (Fig. 7). The frieze is decorated in a wasp motif with intersecting ovals and foliate scrolls at the corners and centers in sgraffito.<sup>4</sup> This decoration is virtually identical to a frame in the Pinacoteca Nazionale in Bologna dating from the early seventeenth century (Morazzoni 1953:22; Cammarota 1995).<sup>5</sup> The blue paint on the frieze is extremely coarse and thickly applied. The sight and outer moldings have been overgilded, and the fascia has been overpainted at the edge of the outer molding, where the overgilding on the outer molding continued onto the fascia.

Of the four frames in this study, frame 0414 (Fig. 8) has undergone the most restoration. Although the areas decorated with the opaque blue sgraffito in a strapwork design appear to be intact, the red-painted central diamonds and corner rosettes have been extensively inpainted and regilded. The blue paint on this frame is very similar in texture to that on frame 0321 (Fig. 1); it is coarser than that of frame 0392 (Fig. 3) and finer than on frame 0393 (Fig. 6). Frame 0414 is made of a hardwood with the appearance of poplar and is joined with half dovetail laps with mitered sight and outer moldings nailed to the back frame (Fig. 9).

## Comparative Sources for Analysis

Previous studies exploring design and production of Renaissance frames have primarily concentrated on fabrication of the wood substrate (Gilbert 1977; Morazzoni 1944:7–46; Bisacca and Kanter 1990; Matthew 1988:211–65), but they indicate that the decoration could have been undertaken by fine artists as well as artisans. Although there were artisans who specialized in painting three-dimensional wooden objects, such as chests and polychrome sculpture (Cole 1983:162), easel painters were also very involved in the design and production of frames (Gilbert 1977:13–16, 20;



Figure 5  
Detail of *cassetta* frame 0392 (shown in Fig. 3): upper proper left corner with rosette removed.

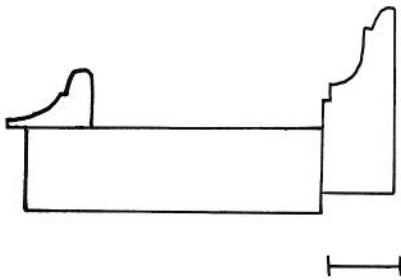

Figure 7  
Profile drawing of *cassetta* frame 0393 (shown in Fig. 6). Scale bar represents 2.54 cm.

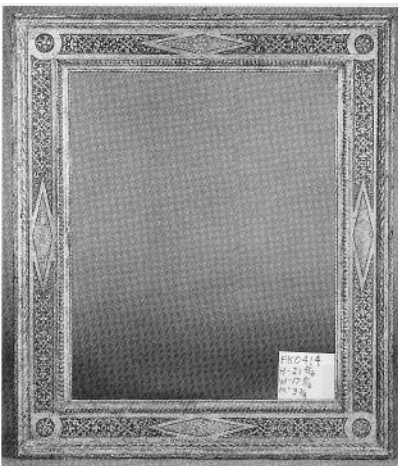

Figure 8  
*Cassetta* frame. Venice, sixteenth century.  
Polychromed and gilded wood. 72.1 × 62.9 cm.  
Samuel H. Kress Foundation Collection,  
National Gallery of Art, frame 0414.

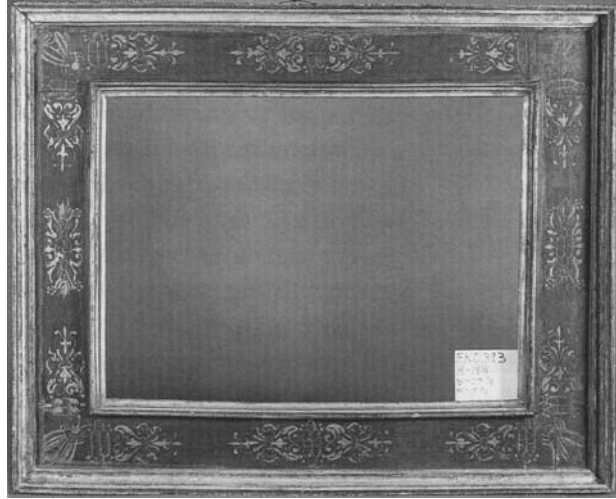

Figure 6  
*Cassetta* frame. Venice, sixteenth century.  
Polychromed and gilded wood. 77.2 × 94.3 cm.  
Samuel H. Kress Foundation Collection,  
National Gallery of Art, frame 0393.

Lydecker 1987:126). Early in the Renaissance, when panel paintings were produced in engaged frames, the individual who painted the image on the panel was also likely to have painted decorations on the attached frame. This trend may have continued into the early sixteenth century when frames were engaged onto paintings on canvas, whereby the painting's stretcher or strainer was used as a back frame, to which decorated moldings were nailed (Newbery and Kanter 1990). Two painted and gilded Venetian frames of this type, still bearing remnants of the paintings they once housed in their rabbets, are part of the Kress Collection of frames at the National Gallery.

The Venetian painter Lorenzo Lotto (ca. 1480–1556) often described in his account book whether the frames on the paintings he sold were gilded, black, or walnut (Lotto 1969:146, 150, 232). Although he painted frames for many of his smaller pictures and portraits (Matthew 1988:199), the account book indicates that gilders and painters were also subcontracted for their fabrication (Lotto 1969:167–68). Thus, the close tie between painters and frame makers would suggest that there would be similar sorts of materials used in their products.

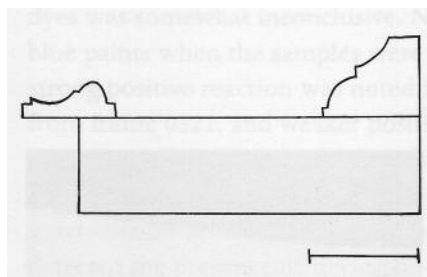

Figure 9  
Profile drawing of *cassetta* frame 0414 (shown in Fig. 8). Scale bar represents 2.54 cm.

The blue pigment that seems to have been used most often on Italian polychrome sculpture is azurite (Pandolfo 1988:12). Studies of three sixteenth-century Northern Italian altarpieces reveal that natural ultramarine was simulated by laying azurite on a thick layer of red lake, and smalt was noted in one location (Galassi, Fumagalli, and Gritti 1991:200). In studies of Venetian easel paintings, smalt and indigo were found in addition to azurite and ultramarine on works produced in the sixteenth century (Lazzarini 1983:136), and smalt has very rarely been found on paintings dating prior to 1500 (Mühlethaler and Thissen 1993:114).

Binding media in paints used on Italian polychrome sculpture were generally proteinaceous, egg tempera, or glue (Galassi, Fumagalli, and Gritti 1991:199; Pandolfo 1988:11). Studies of sgraffito on fourteenth-century Italian paintings indicate that the exact type of medium was dependent on the pigment used (Halpine 1995:41–48). Cennino Cennini and Giorgio Vasari dictated the type of binding media to be used with various pigments—in particular, the use of glue with ultramarine and other blues (Vasari 1960:224; Cennini 1960:88–89). Cennini also recommended using red lake in oil medium in a glaze over vermilion in egg tempera to depict brocade cloths, which were often illustrated by using the sgraffito technique (Cennini 1960:88). This suggests that oil medium might also be observed on some sgraffito-decorated surfaces.

---

## Analytical Methods

Samples of dispersed pigment were examined with a polarizing light microscope for pigment identification. Cross-sectional samples from the blue painted areas of friezes were embedded in polyester resin and examined microscopically in visible and ultraviolet light. For media characterization, the samples were stained with reactive dyes—fluorescein isothiocyanate (0.2% in acetone) for protein and dichlorofluorescein (0.2% in acetone) for

*Figure 10a–d*  
Cross sections of paint layers from *cassetta* frames 0321 (a), 0392 (b), 0393 (c), and 0414 (d) in reflected light. Magnification  $\times 123$ .

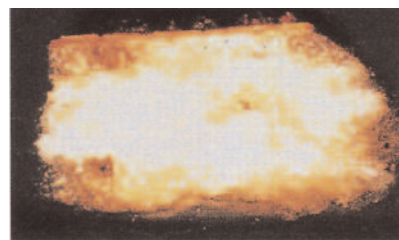

a

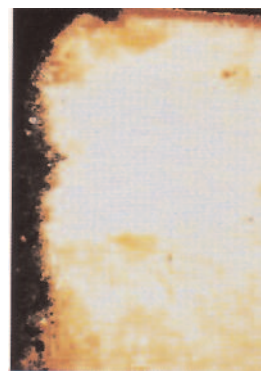

b

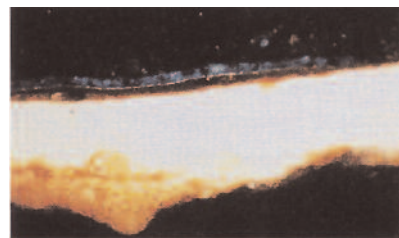

c

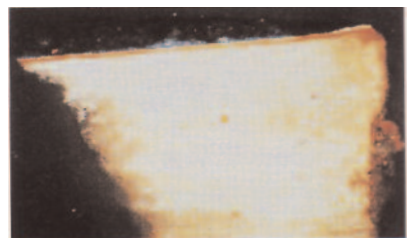

d

oil—and were examined under a Leitz ultraviolet-light microscope with an I  $\frac{2}{3}$  filter cube. The cross sections were also examined with the scanning electron microscope, and pigment identifications were confirmed with energy-dispersive X-ray analysis. Characterizations of binding media were supplemented using gas chromatography–mass spectroscopy and high-performance liquid chromatography.

---

## Results of Analysis

The gilding preparation for the four frames in the study is extremely similar. In all cases, the gesso ground is applied in several layers and consists primarily of gypsum with some calcium sulfate anhydride. Rhombohedral inclusions of dolomite ( $\text{CaCO}_3 \cdot \text{MgCO}_3$ ) are observed on the gesso layers of frames 0321 and 0414 on the scanning electron micrograph.

The bole layer observed in the cross sections is rather thin, measuring 10–18  $\mu\text{m}$  in thickness. On all of the frames, the bole is finely ground and pale orange in color, with the exception of frame 0393, on which the bole is red brown.

All of the painted layers on all frames were simple mixtures of blue and white pigments (Fig. 10a–d). The blue painted areas on frame 0393 (Fig. 10c) and frame 0414 (Fig. 10d) are structurally identical. Each has a dark paint layer, with coarsely ground blue pigment particles topping a paint layer with finely ground white and blue pigment particles. Smalt and lead white were found on both frames, but the blue paints on frame 0414 also contain gypsum, cobalt blue, and azurite.

The cross sections from frame 0392 (Fig. 10b) show a single, dark blue paint layer above the gold leaf, the simplest structure in this group. The pigments are smalt, cobalt blue, and carbon black. Of the four frames discussed, the most complex system of paint application was on frame 0321 (Fig. 10a). A blue-green layer of paint containing coarsely ground heterogeneous, natural malachite, azurite, and dolomite was placed over a transparent red paint layer containing red lake and dolomite. The amount of malachite compared to azurite in the upper layer varies from area to area on the frame. Samples of the upper paint layer from the central lozenges are almost entirely azurite, whereas the samples from the corner circles are almost entirely malachite. This suggests that some areas were intended to appear more bluish green, while others were to appear greenish blue. There is also the possibility that the frame painter intended to imitate ultramarine by layering azurite over red lake, as noted by Galassi, Fumagalli, and Gritti (1991:200).

On the cross sections, the media characterization using reactive dyes was somewhat inconclusive. No reaction was observed in any of the blue paints when the samples were stained with dichlorofluorescein. A strong positive reaction was noted in the blue painted layers in samples from frame 0321, and weaker positive reactions were noted in the blue paints in samples from the other three frames using fluorescein isothiocyanate, indicating the presence of protein. Gas chromatographic–mass spectroscopic analysis of the blue paint samples on all of the frames detected the presence of drying oil—probably linseed oil, based on the ratios of methyl palmitate to methyl stearate (Lomax 1995). Small amounts of diterpenes, indicative of pine resin materials, were noted in the blue paint chromatograms for frames 0392 and 0393, and peaks relating to wax were noted in the chromatograph for frame 0321. As for amino

acid analysis with high-performance liquid chromatography, glue and egg yolk were detected in the blue paint on frame 0393 (Halpine 1994a). The high-performance liquid chromatographs for the samples taken from frames 0321, 0392, and 0414 bore no relationship to glue, egg white, egg yolk, or casein; and only trace amino acids were found (Halpine 1994b).

---

## Conclusion

The simplicity of the paint application and of the pigment mixtures in the paints argues favorably for the antiquity of the painted decoration on these frames. The pigments found on all four frames have been in use since the sixteenth century and have been found on Venetian easel paintings (Lazzarini 1983:135–144) and Northern Italian polychrome sculpture of the period (Galassi, Fumagalli, and Gritti 1991:200). In fact, with the exception of dolomite, these pigments have had widespread use since 1500 throughout Europe. Dolomite, also found as a transparent extender in paints on works by Giovanni Bellini (Venetian, ca. 1430–1516), may be particular to Italian painting and frames, but the incidence of fillers of this type are not often reported in the literature (Gettens, FitzHugh, and Feller 1993:204, 210; Berrie 1994). The presence of dolomite in the paint and gesso on frame 0321 and in the gesso on 0414 enhances the credibility of the sixteenth-century Venice attribution.

The results of the media analysis were unexpected, since the media were presumed to be proteinaceous materials, based on the types of materials generally used in sgraffito decoration. However, the oil medium on these frames could provide another reason behind the painters' choice of smalt as a blue pigment on frames 0392, 0393, and 0414. Smalt's siccativ effects on oils had been noted early on (Mühlethaler and Thissen 1993:116). The oil medium for the blue and green paints on frame 0321 also elucidates why these two colors are now indistinguishable by simple visual examination. This phenomenon has been previously reported on three easel paintings at the National Gallery, London, where thick layers of azurite in oil have turned greenish in color (Gettens and FitzHugh 1993:27). The discoloration was tied to yellowing of the paint medium rather than to conversion of the azurite pigment particles into malachite.

Of interest is the relative sophistication in the manner in which the sgraffito was executed, which did not extend to the manner in which paint was applied. The pigments used in the paint layers, and the way they were applied to the unsophisticated frieze, on frame 0393 are very similar to those used on a frieze having a more intricate design seen on frame 0414. The difference in the handling of the materials could be ascribed to the relative thicknesses of the paint layers. The paint on frame 0393 is twice as thick as that on frame 0414, and it contains much larger smalt particles.

Since a larger body of technical information about painted Italian frames with known provenance has not been established thus far, the results of this study are simply observations about these particular frames. As indicated above, the pigment analysis revealed unexpected similarities between two frames that could not be detected from simple visual examination.

Broader conclusions relating to the production of frames in Venice cannot yet be drawn. Work also needs to continue in areas other than the technical aspects of frames. In the case of frame 0393, the scant body of art historical information currently available has provided as many

clues to the frame's origin as the technical analysis. The contribution of information from archives, depictions of interiors, and frames from other collections in exhibition catalogues and other publications has been vital. A continued investigation into the provenances of individual frames in the collection, as well as into the materials used in the creation of these frames, must ensue for the National Gallery's frame inventory database to be a truly useful research tool for curators, exhibition designers, and conservators (National Gallery of Art 1994:38). By increasing the volume of information available about each frame, these objects can be better understood as works of art and better utilized in that context in their display.

---

## Acknowledgments

This investigation was undertaken at the National Gallery of Art with funding from the Samuel H. Kress Foundation. The author would like to thank Mervin Richard and Stephan Wilcox for their support of this project. The author also thanks Mario Modestini, Diane Dwyer Modestini, and Anne Kelley for their help during the research on the history of the collection; Barbara Berrie, Susana Halpine, Suzanne Lomax, and Michael Palmer of the National Gallery's Scientific Research Department for performing the technical analyses and for their helpful comments regarding them; and Janice Gruver, who contributed useful advice on manuscript preparation.

---

## Notes

- 1 The following definitions of frame types and related terms were adapted from Newbery 1990: *Cassette*: a rectangular frame with applied sight and outer moldings and a flat frieze (pl. *cassette*). *Reverse profile*: a frame with its highest molding on the sight edge. *Sight*: the edge or molding closest to the framed object. Also, the dimension of the framed object that is visible. *Tabernacle*: an architectural frame consisting of an entablature supported by columns or pilasters, with or without a crowning pediment or a supporting predella. *Tondo*: a circular frame with a circular opening (pl. *tondi*).
- 2 In a conversation in New York in 1994, Mario Modestini (formerly the conservator in charge of the Samuel H. Kress Foundation Collection) told the author that, before moving to the United States, he sold his collection of frames—housed in his studio in Rome—to Contini-Bonacossi.
- 3 *Pastiglia* ornamentation, used in Italy since medieval times for decorating furniture, is a mass containing gypsum and glue—or lead white and egg—that can be applied directly or molded, then stained with color, painted, or gilded.
- 4 Although a number of sources—including the nine-volume encyclopedia of Italian heraldry (Spreti et al. 1928–35)—were consulted, the meaning of the interlaced oval symbol has not been determined. Although the wasps could also be interpreted as bees, it is more common in Italian heraldry for bees to be depicted with their wings open.
- 5 The frame's current location is unknown, and there is no indication in the records of the Pinacoteca Nazionale regarding what painting the frame held.

---

## References

- Berrie, B.  
1994 Conversation with the author, Scientific Research Department, National Gallery of Art, Washington, D.C.
- Bisacca, G., and L. B. Kanter  
1990 *Italian Renaissance Frames*, 11–30. Exhibition catalogue. New York: Metropolitan Museum of Art.

- Bowron, E. P.**  
1994 The Kress brothers and their "bucolic pictures": The creation of an Italian baroque collection. In *A Gift to America: Masterpieces of European Painting from the Samuel H. Kress Collection*, 41–59. Exhibition catalogue. Raleigh, N.C.: North Carolina Museum of Art.
- Cammarota, G.**  
1995 Letter to the author, Archivio Pinacoteca Nazionale, Soprintendenze Beni Artistici e Storici, 40126 Bologna, Italy.
- Cennini, C.**  
1960 *The Craftsman's Handbook: The Italian "Il libro dell'arte,"* trans. Daniel V. Thompson Jr. New York: Dover.
- Cole, B.**  
1983 *The Renaissance Artist at Work: From Pisano to Titian.* New York: Harper and Row.
- Galassi, A. G., P. Fumagalli, and E. Gritti**  
1991 Conservation and scientific examination of three Northern Italian gilded and painted altarpieces of the sixteenth century. In *Gilded Wood: Conservation and History*, ed. D. Bigelow, 193–203. Madison, Conn.: Sound View Press.
- Gettens, R. J., and E. W. FitzHugh**  
1993 Azurite and blue verditer. In *Artists' Pigments: A Handbook of Their History and Characteristics*. Vol. 2, ed. A. Roy, 23–26. Washington, D.C.: National Gallery of Art.
- Gettens, R. J., E. W. FitzHugh, and R. L. Feller**  
1993 Calcium carbonate whites. In *Artists' Pigments: A Handbook of Their History and Characteristics*. Vol. 2, ed. A. Roy, 183–202. Washington, D.C.: National Gallery of Art.
- Gilbert, C.**  
1977 Peintres et menuisiers au debut de la Renaissance en Italie. *Revue de l'Art* 37:9–28.
- Halpine, S. M.**  
1994a Addendum to Amino Acid Analysis Report dated July 30, 1994. Scientific Research Department, National Gallery of Art, Washington, D.C., 9 December.  
1994b Amino Acid Analysis Report, Scientific Research Department, National Gallery of Art, Washington, D.C., 30 July.
- 1995 An investigation of artists' materials using amino acid analysis: Introduction of the one-hour extraction method. *Conservation Research* 1995 51:29–69.
- Lazzarini, L.**  
1983 Il colore nei pittori veneziani tra il 1480 e il 1580. *Bollettino d'Arte* 5 (supp.):135–44.
- Lomax, S. Q.**  
1995 Analysis Reports, Scientific Research Department, National Gallery of Art, Washington, D.C., 10 and 20 April.
- Lotto, L.**  
1969 *Il "libro di spese diverse" con Aggiunto di Lettere e d'Altri Documenti*, ed. P. Zampetti. Venice: Istituto per la Collaborazione Culturale.
- Lydecker, J. K.**  
1987 The domestic setting of the arts in Renaissance Florence. Ph.D. diss., Johns Hopkins University, Baltimore, Md.
- Matthew, L. C.**  
1988 Lorenzo Lotto and the patronage and production of Venetian altarpieces in the early sixteenth century. Ph.D. diss., Princeton University, Princeton, N.J.



- Modestini, Mario  
1994 Conversation with author, New York City.
- Morazzoni, G.  
1944 *Le cornici veneziane*. Milan: Edizione Luigi Alfieri.  
1953 *Le cornici bolognesi*. Milan: Edizione Luigi Alfieri.
- Mühlethaler, B., and J. Thissen  
1993 Smalt. In *Artists' Pigments: A Handbook of Their History and Characteristics*. Vol. 2, ed. A. Roy, 113–30. Washington, D.C.: National Gallery of Art.
- National Gallery of Art  
1994 1993 Annual Report. Washington, D.C.
- Newbery, T. J.  
1990 Glossary to *Italian Renaissance Frames*, 105–9. Exhibition catalogue. New York: Metropolitan Museum of Art.
- Newbery, T. J., and L. B. Kanter  
1990 *Italian Renaissance Frames*. Exhibition catalogue. New York: Metropolitan Museum of Art.
- Pandolfo, A.  
1988 Aspetti tecnici e conservativi della scultura lignea policroma. *Kermes* 1(1):9–14.
- Perry, M.  
1994 The Kress collection. In *A Gift to America: Masterpieces of European Painting from the Samuel H. Kress Collection*, 13–35. Exhibition catalogue. Raleigh, N.C.: North Carolina Museum of Art.
- Spreti, Vittorio, et al.  
1928–35 *Enciclopedia storico-nobiliare italiana*.
- Vasari, G.  
1960 *Vasari on Technique*. Ed. G. Baldwin Brown, trans. Louisa S. Maclehorse. New York: Dover.

# The Imitation of Natural Materials in Architectural Interiors

*Ian C. Bristow*

THE USE OF PAINTED WOOD to imitate more expensive natural materials—exotic woods, marquetry, stone, tortoiseshell—is well documented in historic British interiors.<sup>1</sup> The use of imitations was thoroughly established in England long before the discovery of America and the advent of European building methods and techniques. Marbling had been practiced in medieval Britain in both secular and domestic buildings, a notable example being the “marble colour” that Henry III ordered to be applied to the piers of his aisled hall at Ludgershall, Wiltshire, in 1246; the pillars and arches in the whitewashed King’s Hall at Guildford Castle, Surrey, were similarly treated in 1256 (Clapham 1937:32; Clapham and Storey 1959:289). Such embellishments remained popular during the sixteenth century; in 1597–98, for instance, the King’s Sergeant Painter, Leonard Fryer, was paid for painting the paneling in the Gallery at Oatlands, Surrey, “with soundry cullours curiously grayned w<sup>th</sup> a grayne called flotherwoode.” It is interesting to note that the panels were further embellished with “droughts . . . of markatree,” possibly a reference to the imitation of inlay.<sup>2</sup>

---

## The First Half of the Seventeenth Century

When John Smythson visited the king’s house at Theobalds, Hertfordshire, in 1618, he made a sketch of the paneling in the Great Chamber, noting the panels decorated in figured “wallnuttree Culler,” surrounded by black with gold moldings (Richardson 1976:99, no. 28). Imitative techniques thus came readily to hand in the pursuit by Inigo Jones of his noble ideal of Italian architecture. Jones had been appointed Surveyor of the King’s Works in 1615, and the doorcase he designed in the late 1620s for his remodeling of the Queen’s New Cabinet Room at Somerset House, London, for example, was painted like white marble (probably with gray veins) and its enrichments were gilded<sup>3</sup> (Harris 1972:15, no. 40). This treatment is paralleled by the doorcases in the staircase at Ham House, Surrey, which in 1638 were “Layde over twice w<sup>th</sup> waitlead in Nutt [walnut] Oyll and varnished and vayned as polished Marble.” The doors within them were painted “walnuttree cullo<sup>r</sup>,” the general effect being seen clearly in the restoration effected by the Victoria and Albert Museum a few years ago.<sup>4</sup> This tonality of dark doors within lighter openings seems, incidentally, to have been quite common, and was to be found at the Queen’s House, Greenwich, Kent, where the doors in Inigo Jones’s Hall, set within

Portland stone doorcases, were originally painted a dark brown, probably in the late 1630s (Bristow 1986:28–30).

The 1638 painter's account for Ham is also notable in showing the extent to which graining was used on paneling. The paneling then in the Hall, for example, which probably stood to three-quarters of the wall height, was grained in imitation of walnut, as was the joinery of the staircase balustrade. Cornices in several chambers, below which hangings would have been suspended, were also either grained or marbled.<sup>5</sup>

---

## The Second Half of the Seventeenth Century

Following the interregnum and restoration of the English monarchy in 1660, Christopher Wren and his contemporaries employed graining and marbling on a large scale; the flowering of Baroque architecture in Britain, for which they were responsible, was particularly notable for its illusionistic effects. Paneling was commonly grained in imitation of oak, walnut, or cedar; and references also exist to the imitation of olive and princewood. Accounts of the period suggest that, most commonly, a single timber was imitated in any one room; the Earl of Danby's Dining Room at Whitehall, for example, was painted "walnut tree colour pencill grained" in the late 1670s.<sup>6</sup> It is also clear that a single imitation might be used throughout an apartment—for example, the deal wainscots in the consecutive presence chambers (or antechambers), bedchambers, and closets in the apartments formed for the Duke and Duchess of York (later James II and his queen) at Hampton Court, Surrey, in the early 1670s, were all painted walnut tree color.<sup>7</sup>

More elaborate schemes were nevertheless adopted on occasion. Part of one example survives in Morton's Tower at Lambeth Palace, London, its date being given on the trompe l'oeil chimneypiece as 1691. A similar scheme was apparently executed the same year at Erdigg, Debigshire (now Clwyd), described as "painted very well the pannells are resembling Yew, the stiles [?] to prince wood, and the moulding a light color" (Cust 1914:41). Natural timber paneling of this richness also seems to have been made, since Celia Fiennes (in Morris 1947:153) described the Hall at Chippenham Park, near Newmarket, Cambridgeshire, as:

wanscoated with Wallnut tree the pannells and rims round with Mulbery tree that is a lemon coullour and the moldings beyond it round are of a sweete outlandish wood not much differing from Cedar but of a finer graine.

Comparable paneling in cedar and Virginian walnut survives in the early eighteenth-century Talman wing at Dyrham Park, Gloucestershire (now Avon).

An alternative taste was to paint paneling in imitation of marble. White marble with gray veins seems to have been the most common choice. Examples include the King's Supping Room at Whitehall, which was painted "white marble varnisht and veined in distemper" in 1662,<sup>8</sup> while paint samples from the North Drawing Room at Ham show it has been marbled in oil since at least the 1670s, when the paneling was assembled in its present form (Bristow 1984).

As with graining, more elaborate schemes were also to be found. In 1680, all the "wainscott worke carveing & window shutters" in the Duchess of York's Privy Chapel at Saint James's Palace were painted to

resemble “lapis lazuli & Raince marbell [a reference to *rance*, a dull red marble mottled and veined with gray and white] & white & black marbell;<sup>9</sup> and beneath the present graining in the Balcony Room at Dyrham lies the original splendid scheme of marbling applied to the paneling when it was erected in 1694. Paint samples have shown that imitations of porphyry and a large-figured, orange-pink marble were deployed (Bristow 1979)—a scheme of particular interest, since it was executed by a painter named Hauduroy (probably the Huguenot, Mark Anthony Hauduroy) and may be correlated with almost contemporary advice on marbling offered by the French architect Auguste Charles D’Aviler in 1691. Discussing the imitation of various materials in paint, he observed:

One should never imitate marble where it could not exist in reality, as on doors and window casements. It is necessary to vary the marbles between the different architectural elements, so that the architrave and cornice should be of one colour and the frieze of another. In panelling, the framing should be different from the panel mouldings, and the mouldings different from the panels. . . . In varying the marbles one should ensure that the colours do not destroy each other by having too great a contrast, and that moulded parts should be painted with soft colours [he probably means marbles without pronounced veining] so that their profiles can be well read.

The avoidance of strong contrasts seems to have been of particular concern to D’Aviler; and in the use of natural stones or marbles to differentiate architectural elements, a practice of which he warmly approved, he stressed particularly the need to eschew the placing of white against black. Instead, he preferred the use of white, gray, or reddish stones; and for the fields of panels, he particularly recommended as appropriate the employment of a breccia or a white marble with gray veins. The marbled paintwork of the Balcony Room is clearly consistent with the spirit of this advice, notably in the use of porphyry on the moldings, which would allow their profiles to be read without distortion, as D’Aviler had adumbrated (D’Aviler 1691:230, 339).

However, paint samples taken from the doors suggest that Hauduroy committed the solecism of marbling them, and marbled doors also feature in the upper room at Swangrove, a hunting lodge on the Badminton estate, Gloucestershire, in which japan (lacquer) motifs are imitated on the stiles and rails. Japanning was also a popular taste, which cannot be discussed here, but was to be found at Dyrham in a now-destroyed room, while other examples were to be found at Chatsworth, Derbyshire, and at Hampton Court Palace.

In addition to its use on paneling, marbling found a particular place on discrete architectural elements such as columns, chimneypieces, and detached sculpture. Certain busts on the now-destroyed staircase at Burley-on-the-Hill, Rutland (now Leicestershire), were painted in imitation of lapis lazuli by Gerard Lanscroom sometime before 1700, while its columns were painted in imitation of a red marble (Croft-Murray 1962:254). Earlier examples include the columns in Christopher Wren’s Sheldonian Theatre, Oxford, which were “don like Rance w<sup>th</sup> a high varnish” in 1669 (Bolton and Hendry 1924–43:19:99); and in the mid-1690s Celia Fiennes recorded that in the Hall at Broadlands, Hampshire, were “severall rows of Pillars of wood painted like marble for to walke between” (Morris 1947:55).

Prior to the advent of modern heating methods, the fireplace occupied an important, even symbolic, position in interiors. Special care was thus lavished on it, and its eminence was often emphasized by the use of expensive and exotic marbles. The expense of real marble could not always be afforded, however, and the material was often simulated in paint. Thus, Sir Balthazar Gerbier (1663:22) observed: "The Chimney-mantles ought to be all of Stone or Marble, but if (to spare charges) the upper frame, sides and top be made of timber it will be most seeming to have them painted as Marble."

Examples of marbling on such elements may even be found in royal buildings. The chimneypiece in the King's Guard Chamber at Whitehall, for example, was marbled in 1687;<sup>10</sup> and there is an item in the Kensington Palace accounts for "veining a chimneypiece" in 1692.<sup>11</sup> D'Aviler's advice on marbling wainscot has already been mentioned, and, in commenting on his design for a grand chimneypiece, he noted, "The frames of a chimney as rich as this should be of marble, and the remainder of the same material or of joinery painted in marbles of diverse colours" (D'Aviler 1691:166).

Tortoiseshell also was commonly imitated. It was used notably on the columns and friezes of the new altarpiece designed by Wren for the Tudor Chapel at Whitehall in 1676; the remainder was painted cedar color.<sup>12</sup> In 1688, however, John Stalker and George Parker commented critically on the generally poor quality of the imitation as provided by house-painters (Stalker and Parker 1971:79). Indeed, there seems little doubt that the quality of seventeenth-century imitations could vary widely, and in a memorandum attached to the painter's estimate for decorating his Library at the Lincoln Cathedral, Wren noted, "Ranse Marble & indian woods extraordinarily well don soe as to deceive the Eye & be taken for naturall may be worth 4 shillings the Yarde or more," although he had suggested only 1s.4d. or 1s.6d. for ordinary imitations of walnut or "indian Woods" (Lincoln Cathedral Library).

Among the most ambitious illusionistic effects of the period must have been the king's canopy in the Tudor Chapel at Whitehall Palace, which the King's Sergeant Painter Robert Streater painted with fine lake in 1675 to represent crimson velvet, with gilding "flickered," as the account puts it, to imitate embroidery and the pile of the material.<sup>13</sup> A comparable instance was to be found at Lichfield Cathedral when Fiennes visited in 1697; she noted there was "a painting over the Communion table of peach coullour satten like a cannopy with gold fringe, and its drawn so well that it lookes like a reall cannopy" (Morris 1947:111). Although neither of these examples survives, the still-extant carved and painted curtain above the family pew in the Chapel at Petworth House, Sussex, may originally have been similarly rich.

---

## The Early Eighteenth Century

The use of imitations continued into the first half of the eighteenth century. For example, the Dining Room at the Ivy, Chippenham, Wiltshire, built about 1730, was painted at an early date in imitation of a dark green marble with white veins; and the Chandos Mausoleum by James Farquharson and James Gibbs was decorated around 1736 by Gaetano Brunetti with an elaborate scheme involving marbled walls.<sup>14</sup> Nevertheless, although William Kent made extensive use of marbling in the 1720s in his painted decoration on the ceiling in the Cupola Room at Kensington

Palace, it seems that, under the Palladians, graining and marbling fell from vogue. Robert Campbell (1747:103) complained of the low standards prevailing among painters, noting:

When it was the Taste to paint Houses with Landskip Figures, and in Imitation of variegated Woods and Stone, then it was necessary to serve an Apprenticeship to the Business . . . but since the Mode has altered, and houses are only daubed with dead Colours, any Labourer may execute it as well as the most eminent Painter.

Nevertheless, the technique did not die out completely, and one still finds occasional references to doors being grained in the 1750s and 1760s, while marbling survived notably on floorcloths.

## Techniques



*Figure 1*  
Cross section from an area of orange-pink marbling dating from 1694 in the Balcony Room at Dyrham. Viewed by reflected visible light (quartz-halogen source). A dirt line separates the ground for the later graining from the original scheme, which is built up from several layers of opaque paint.

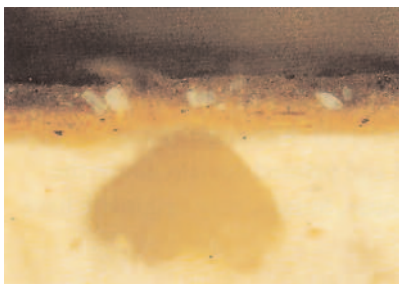

*Figure 2*  
Cross section from an area of graining, probably of late-seventeenth-century date, imitating walnut, at the Queen's House, Greenwich. Viewed by reflected visible light (quartz-halogen source). Above the plaster ground are two opaque browns, to which darker veins have been added.

When the use of imitations was revived at the end of the eighteenth century, it was with the aid of improved techniques. In general, during the seventeenth century and earlier parts of the eighteenth, the figure of timber or marble had been built up in more or less opaque paint, often worked wet into wet. The typical appearance of a mounted cross section of marbling executed in oil in this way may be seen in an example from the Balcony Room at Dyrham (to which reference has already been made), the successive layers of opaque paint often having poorly defined boundaries (Fig. 1).

Similarly, a sample of graining from the Queen's House at Greenwich (here applied to plaster and probably dating from the end of the seventeenth century) shows the application of a darker brown on a lighter ground in the imitation of walnut, with a few still darker veins added above (Fig. 2).

At the end of the eighteenth century, a refined technique of graining was developed, based on the application of transparent darker glazes above a ground matching the lightest color in the timber to be imitated. Once the ground was dry, the glazes were applied evenly to it, and then brushed, wiped out, or otherwise manipulated to allow the base color to grin through. The method was illustrated by Nathaniel Whittock in his *Decorative Painters' and Glaziers' Guide* of 1827 and may be seen clearly in his plate showing the imitation of satinwood (Fig. 3). Typical of the implements used are brushes of various forms to create streaked effects, as well as combs (examples of which were illustrated by Whittock, shown here in Fig. 4), feathers, and pieces of leather or cork, all familiar to the modern-day practitioner.

On joinery items, the ground was generally oil, but the glazes could be in either an aqueous medium (commonly stale beer) or a mixture of organic compounds—including oil of turpentine, linseed oil, or wax—the resulting preparation being known as *megilp*. Both have the property of preventing the glaze from running back when manipulated, and of drying sufficiently hard to permit the application of darker veins or successive coats of glaze to add depth to the imitation. On completion, the finished graining was generally varnished (Fig. 5). Of course, the earlier methods were not completely superseded, and, for marbling in particular, veins were commonly added using more or less opaque paint, as shown by Whittock in the imitation of porphyry (Fig. 6).

Figure 3  
Stages in the imitation of satinwood  
(Whittock 1827:pl. 9).

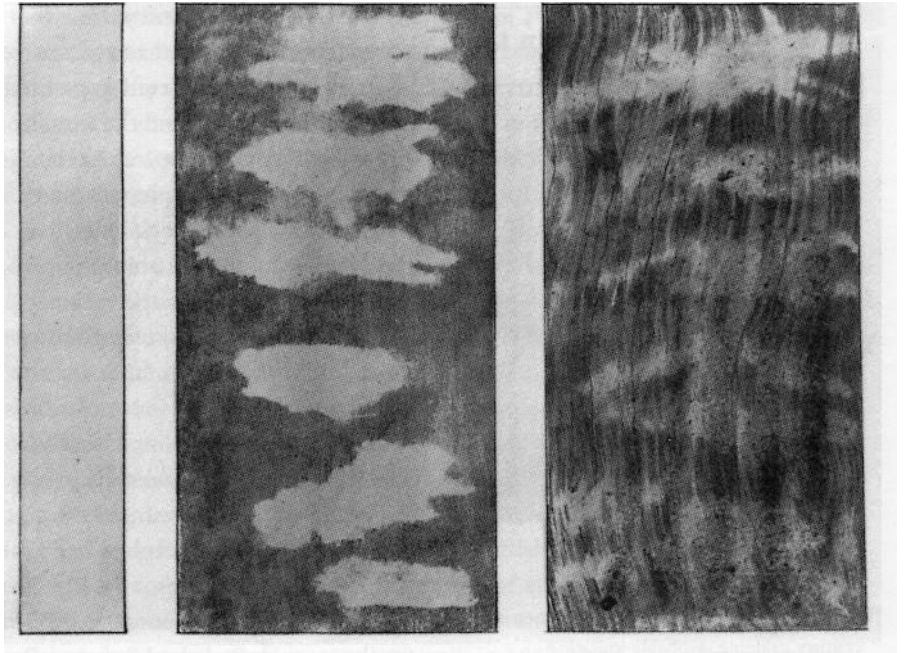
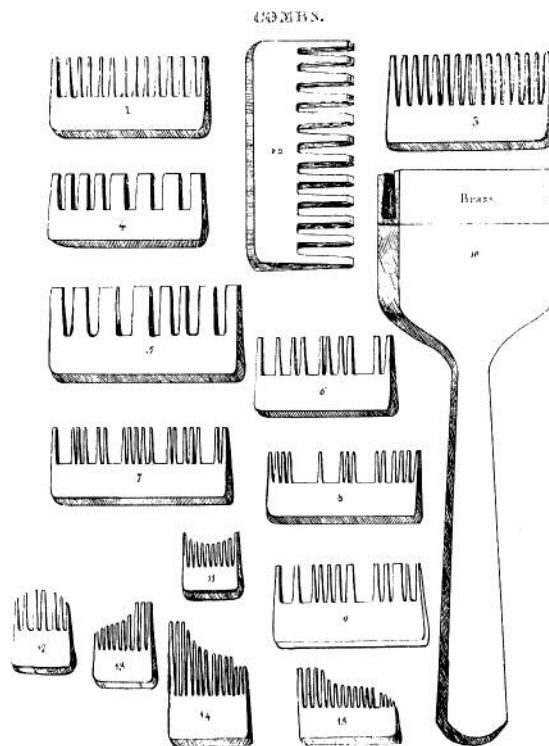

Figure 4  
Graining combs (Whittock 1827:pl. 2).



Besides his illustrations, Whittock gave good descriptions of the developed methods used in the early nineteenth century, and further suggestions were included by the London paint manufacturer and merchant T. H. Vanherman in his *Painter's Cabinet* (1828:58–64). Earlier authors give little coherent information, but the best account of the older techniques is probably to be found in Hezekiah Reynolds's *Directions for House and Ship Painting* (1812:18–21).

## Revival of Imitations in the Early Nineteenth Century

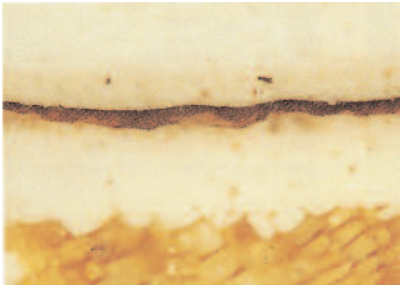

Figure 5  
Cross section from an area of mid-nineteenth-century graining, probably imitating mahogany, from the Dining Room at Frogmore House, Windsor. Viewed by reflected visible light (quartz-halogen source). Above earlier schemes in white, a pinkish ground is overlaid by a thin glaze, varnish, and a later overpaint.

As the eighteenth century drew to a close, architectural Neoclassicism was pursued with ever increasing archaeological rigor. By the early nineteenth century, this was reflected in painted finishes, especially in the revival of the use of marbling and the imitation of bronze in interiors. John Soane's Breakfast Room of 1802 at Pitzhanger Manor, Ealing, Middlesex, is an important early example: porphyry, bardiglio, and *verde antico* were imitated on the walls, while the Coade stone caryatids in the four corners of the room were painted in imitation of patinated bronze (Bristow 1987) (Fig. 7).

All his life, Soane retained a fondness for bronzing, and, no doubt inspired by the sets of antique bronze doors (such as those of the Pantheon) that survive in Rome, he used it both internally and externally. In his design for the House of Lords in the 1820s, one can see clearly the rows of studs resembling rivets surrounding the bronze-green door panels,<sup>15</sup> and again externally at the New State Paper Office of 1829.<sup>16</sup> Bronzing was also commonly used on the iron balustrades of staircases, ousting the blue, which had been fashionable in grand buildings during the previous two centuries; an early example dating from about 1802 is to be seen in a design by George Dance the Younger for the staircase at the (sadly) now-demolished Stratton Park, Hampshire.<sup>17</sup>

The imitation of exotic materials played a particularly important part in the Royal Pavilion at Brighton, Sussex, altered and redecorated for the Prince of Wales (the Prince Regent) between 1787 and the 1820s; by 1803, imitated timbers included satinwood, rosewood, tulipwood, and tea wood (Crace 1803). A room elevation of 1802 or earlier shows the use of graining on both the doors and their architraves at a time when, in other fashionable interiors in England, such joinery items were being painted white.<sup>18</sup> This probably reflects contemporary French taste at that time; since, in 1813, Thomas Martin commented, "at Paris, every species of wood-work used in their houses, as a part of the building, is done in this manner. The dead-white so much in vogue amongst us is not practised

Figure 6  
Stages in the imitation of red porphyry (Whittock 1827:pl. 21).

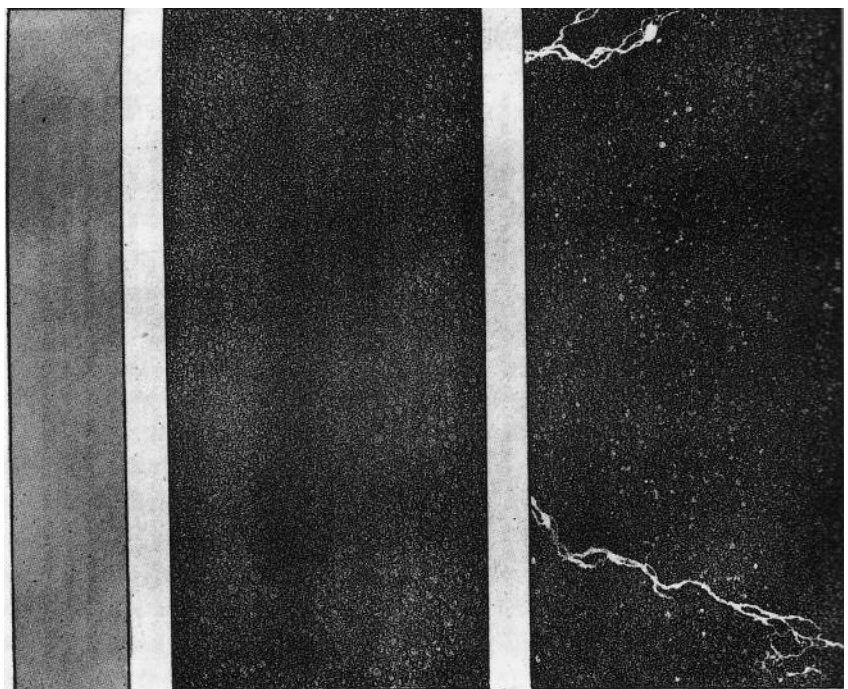





*Figure 7*  
Cross section from an area of bronzing, dating from 1802, on a caryatid in the Breakfast Room at Pitzhanger Manor, Ealing, Middlesex. Viewed by reflected visible light (quartz-halogen source). Above the Coade stone substrate are several layers of white, a coat of dark green, and bronze powder entrapped in a varnish medium.

there” (Martin 1813:464). This reference is of particular interest, as it indicates that in Britain the real popularity of graining did not develop until the years after Waterloo, a suggestion apparently borne out by Nathaniel Whittock, who remarked that it had been the great improvements made in the technique in the ten years before publication of his book that brought graining into general use (Whittock 1827:20).

In the 1820s, graining was commonplace. In the Library at Nostell Priory, Yorkshire, Thomas Ward replaced Robert Adam’s delicate tints with graining (National Trust 1978:10); and, in 1827, Whittock noted, “There are few respectable houses erected where the talent of the decorative painter is not called into action, in graining doors, shutters, wainscots, &c.” (Whittock 1827:20). Perspectives showing the interior of Pellwall House, Staffordshire, designed by John Soane in 1822, show that its joinery was grained;<sup>19</sup> and the same treatment may often be seen in watercolors of the succeeding decades, such as that by Charlotte Bosanquet of 1843 depicting the Drawing Room at Meesdenbury, Hertfordshire.<sup>20</sup> Soon, however, questions were to be asked about the propriety of such imitations. In the “Lamp of Truth,” one of his *Seven Lamps of Architecture*, John Ruskin inveighed against deceptions (Ruskin 1849:32); and, in 1857, the Gothic Revival architect George Gilbert Scott denounced “the whole system of marble-papers in halls, marble and granite painting on shop-fronts, &c., &c., [as] a sort of petty lying without wishing to be believed,—mere falsehood from habit” (1857:243). Nevertheless, graining remained a standard finish on architectural joinery and (allied with marbling on staircase walls) formed the basis for decoration in many humbler homes well into the present century.

## Notes

- 1 For a more in-depth discussion (including details of the various pigments used), see Bristow 1996a, 1996b.
- 2 Manuscript at Public Record Office, London (hereafter PRO) E.351/3233:9 *recto*. Commenting on this, Edward Croft-Murray (1962:27) suggested a flecked or speckled effect was intended, deriving from the word *flother*, meaning a snowflake.
- 3 PRO E.351/3248:7 *verso*.
- 4 Ham boxes, manuscript at Department of Furniture and Woodwork, Matthew Gooderick’s account. Victoria and Albert Museum, London.
- 5 See note 4.
- 6 PRO WORK.5/23.
- 7 PRO WORK.5/24.
- 8 PRO WORK.5/3.
- 9 PRO WORK.5/32.
- 10 PRO WORK.5/41.
- 11 PRO WORK.19/48/1:50(iv).
- 12 PRO WORK.5/27.
- 13 PRO WORK.5/25.
- 14 Print housed at Victoria and Albert Museum, London. E.2-1953.
- 15 Watercolor at Soane Museum, London. Soane perspective albums. 6:33, 37.
- 16 Watercolor at Soane Museum, London. Soane perspective albums. 6:92.
- 17 Drawing at Soane Museum, London. Dance collection. 2/5/24.

- 18 Drawing at Cooper-Hewitt Museum, New York. 1948-40-52.
- 19 Drawing at Soane Museum, London. Soane perspective albums. 6:9–13.
- 20 Watercolor at Ashmolean Museum, Oxford. Bosanquet album. 13.

---

## References

- Bolton, H. T., and H. D. Hendry, eds.**  
1924–43 *Volumes of the Wren Society*. Oxford: Wren Society.
- Bristow, I. C.**  
1979 The Balcony Room at Dyrham. In *National Trust Studies, 1980*, ed. G. Jackson-Stops, 140–46. London: Sotheby Parke Bernet.
- 1984 Ham House, Surrey: Report on an investigation of paint samples from the North Drawing Room and North Front. Author's archive. Typescript.
- 1986 Greenwich, the Queen's House: Report on an investigation into the seventeenth-century painted finishes in the Hall and first-floor rooms. Author's archive. Typescript.
- 1987 The restoration of John Soane's colour scheme in the Breakfast Room at Pitzhanger Manor, Ealing. In *ASCHB Transactions 1986*. Vol. 11, ed. S. Marks, 43–48. Kilmerston: Association for Studies in the Conservation of Historic Buildings (ASCHB).
- 1996a *Architectural Colour in British Interiors, 1615–1840*. New Haven and London: Yale University Press.
- 1996b *Interior House-Painting Colours and Technology, 1615–1840*. New Haven and London: Yale University Press.
- Campbell, R.**  
1747 *The London Tradesman*. London: T. Gardner.
- Clapham, J. B. W., ed.**  
1937 *Calendar of the Liberate Rolls Preserved in the Public Record Office—Henry III*. Vol. 3. London: Public Record Office.
- Clapham, J. B. W., and S. B. Storey, eds.**  
1959 *Calendar of the Liberate Rolls Preserved in the Public Record Office—Henry III*. Vol. 4. London: Public Record Office.
- Crace, J. G. C.**  
1803 Transcript from destroyed original manuscript. Crace ledgers. Royal Pavilion Archive, Brighton, Sussex.
- Croft-Murray, E.**  
1962 *Decorative Painting in England, 1537–1837*. Vol. 1. London: Country Life.
- Cust, A. L.**  
1914 *Chronicles of Erthig on the Dyke*. Vol. 1. London: J. Lane.
- D'Aviler, Auguste Charles**  
1691 *Cours d'architecture*. Vol. 1. Paris: N. Langlois.
- Gerbier, B.**  
1663 *Counsel and Advise to All Builders*. London: T. Mabb.
- Harris, J., ed.**  
1972 *Catalogue of the Drawings Collection of the Royal Institute of British Architects*. Vol. S. Farnborough: Gregg.

- Lincoln Cathedral Library  
n.d. Manuscript. D and C, Cij.31.1.1. Lincoln, England.
- Martin, T.  
1813 *The Circle of the Mechanical Arts*. London: R. Rees.
- Morris, C., ed.  
1947 *The Journeys of Celia Fiennes*. London: Cresset Press.
- National Trust  
1978 *Nostell Priory*. Guidebook. London: National Trust.
- Reynolds, H.  
1812 *Directions for House and Ship Painting*. New Haven, Conn.: Eli Hudson.
- Richardson, Margaret, ed.  
1976 *Catalogue of the Drawings Collection of the Royal Institute of British Architects*. Vol. S. Farnborough: Gregg.
- Ruskin, John  
1849 *The Seven Lamps of Architecture*. London: Smith, Elder, and Co.
- Scott, G. G.  
1857 *Remarks on Secular and Domestic Architecture*. London: John Murray.
- Stalker, J., and G. Parker  
1971 *A Treatise of Japanning and Varnishing*. 1688. Reprint, London: Alec Tiranti.
- Vanherman, T. H.  
1828 *The Painter's Cabinet, and Colourman's Repository*. London.
- Whittock, N.  
1827 *The Decorative Painters' and Glaziers' Guide*. London: Isaac Taylor Hinton.

## Royal Painted Furniture in King Charles I's England

*James Yorke*



*Figure 1*  
Chair, ca. 1630. Gilded with painted decoration. English. Victoria and Albert Museum, London. Inventory no. W58-1953.

THE PUBLIC COLLECTIONS in Europe and North America house a few often rather quaint examples of early painted furniture. Some of this furniture once had substantial traces of pigment. Others had no more than painted coats of arms to identify the owner and reinforce his or her status as a person who could afford prestigious or fashionable possessions. The Victoria and Albert Museum has a very fine armchair of about 1630 (Fig. 1), with sophisticated floral decoration applied to the gilded surfaces of the legs, stretchers, and uprights. It has always been a mystery: although it lacks either coats of arms or any known early provenance, its frame is nevertheless stylistically consistent with fashionable chairs found in England, France, or Holland during this period. Its decoration is quite unlike the heavily carved oak furniture so easily associated in the eyes of posterity with the early seventeenth century. This chair must have been made for someone with fashionable, or at least metropolitan, tastes. Nevertheless, no contemporary document that specifically referred to furniture decorated in this manner has, to date, been traced. The aim of this article is, first, to bring to light some recently discovered bills and what little is known of the artist who submitted them; and, second, to survey examples of painted furniture in English royal inventories and bills of the early seventeenth century.

King Charles I of England (1625–49) was renowned for his patronage of the great British architect Inigo Jones (1573–1652). Charles I strove to create a court as splendid as any in Europe, and he actively collected paintings and sculpture. Although no furniture designs can be safely attributed to Jones, he left plenty of drawings of chimneypieces and other interior features. Both the architect and his patron must have sought furniture that harmonized with these elegant Italianate interiors. Nevertheless, rather than look abroad for appropriate artisans, as they did for artists and sculptors, the king and queen seem to have contented themselves with English joiners, upholsterers, and cabinetmakers.

Much work on this subject has already been done by Hero Granger Taylor, a distinguished textiles specialist, as part of her research during the late 1980s, in connection with the redecoration of the Queen's House at Greenwich, London. She generously supplied the Textile and Dress Collections as well as the Furniture and Woodwork Collections of the Victoria and Albert Museum with copies of bills she found for the years 1635–39 in the London Public Record Office (U.K. PRO 1635, 1639; Jervis 1989). She found names such as Edward Cordell, the queen's cabinetmaker;

Thomas Hardwicke, her trunk maker; Philip Bromefield, her gilder; Ralph Grynder, her upholsterer; and Charles Goodyleare, her joiner.

This author's searches through the earlier years of the king's reign yielded some detailed bills for furniture gilded and painted by Philip Bromefield for Queen Henrietta Maria (U.K. PRO 1630, 1632). Bromefield himself remains something of a shadowy figure: under a variety of different spellings, ranging from Bromfield to Broomfeyld, he occasionally appears in the court minutes of the Painter Stainers' Company of London from 1626 until 1642. He is first mentioned on 1 April 1626, in a case against a certain William Drayton, whose apprentice he had borrowed to work "In the Country" without first paying him. On 6 September 1629, Bromefield was "chosen to be one of the lyverye but preferred to wayte in the Lyverye for this next year ensuing." On 12 December 1638, we learn that "Mr Broomfeyld [*sic*] made not his appearance at the court according to his promise," and on 2 August 1639, "Mr Broomfeld [*sic*] . . . made his appearance at the Court craving p'don for his neglect of gyving the fyne for his wardening but he promises upon his honour to bring it in this court to be paid to go next court day." (The "fyne" he promised to pay was his subscription.) Finally, on 27 October 1642 (Painter Stainers' Co. 1623–49),

it was declared that Mr Joseph Atkinson and Mr Philipp [*sic*] Bromefield have not made their appearance here a long time nor paid any quarterlies or other assets for duties. Therefore it is ordered by the vote and consent of the M[aster] and Wardens and assistants that the said Mr Atkinson and Mr Broomfield [*sic*] shall put among the livery non-attendance. But if they shall come and make their appearance and pay all their duties that are in arrears within two years ensuing the date of this order then they shall be restored into their place & agayne otherwise not.

That is the last that is heard of him: the dates of his birth and death are not yet known, and it can only be said that he flourished between 1626 and about 1640. We know that he was not a very conscientious warden of the painters and stainers but was skilled enough to decorate royal furniture—and for a queen more used to the sophisticated tastes of Paris.

On a bill for work executed between 1 October and 31 December 1630 (Fig. 2) (U.K. PRO 1630), Bromefield described himself as "Her Ma[jes]t[ie]'s Gilder." His work consisted of coloring a screen black, gilding the columns and molding, and decorating cartouches with a combination of gold and silver gilding—for £2—and painting and varnishing a folding stand "fair crimson"—for £1. He also painted "six folding stooles fair carnation" (i.e., very pale pink)—for £1–10–00—and four chairs colored "dark tawny" (i.e., buff colored) with gilded molding and ball finials. The legs and rails of these chairs were "wrought in flowers with all manner of collers" and "curiously shadowed to life varnished at XXV shillings a yard £06–00–00." He supplied six matching stools and a large tawny "great French table," as well. This monumental piece was partly gilded and rested on four pillars at the corners, the fluting of which was "rought in collers and shadowed like ye life." Underneath were two gilded pillars, linked by eight gilded balusters, rather like examples engraved by Jacques Androuet du Cerceau (fl. 1549–84) (Jervis 1974: figs. 73–75). Like the aforementioned chairs, the "long arches," which presumably ran beneath the edges of the tabletop, and connected the pillars in the corners and the upper surface of the table's stretchers (to interpret the meaning of "ye



Figure 3

Daybed, ca. 1630. English. Victoria and Albert Museum, London (Inventory no. W57-1953).



Figure 4

Detail of the floral decoration, English daybed. Victoria and Albert Museum, London (Inventory no. W57-1953).



Figure 5

Thomas White, the soundboard of a virginal, 1642. English. Victoria and Albert Museum, London (Inventory no. W11-1933).



in the Ruckers workshop in Antwerp and (albeit with less virtuosity) Thomas White's in London.

Between July and September 1632, Bromefield was gilding a couch and six folding stools in silver (Fig. 6) (U.K. PRO 1632). He was also painting another couch and set of folding stools green, and gilding them in both gold and silver, and was painting six more folding stools in carnation. In addition, he supplied a "faire greene nambrilla"—presumably a bright green parasol. On 3 August 1635, he supplied eight folding stools, one part of each gilded and "laid in crimson" and "the other part 2 tymes silvered & wrought with yelloow" a screen to match (i.e., "gilded and wrought suitable"). The meaning of the word "laid" is puzzling: possibly part of the pigment lay beneath the surface? In addition, he supplied two folding stools and two square ones, both painted in crimson (U.K. PRO 1635). Finally, on 28 July 1639, he gilded—for £2 each—six folding stools "laid blue," which were destined for Somerset House (aka Denmark House), the former London residence of Queen Anne of Denmark, consort of King James I (who reigned from 1603 to 1625). In addition, these chairs were "offailed lyke unto the blewe damaske & varnished" (U.K. PRO 1639). *Offail* is a variant spelling of *offal*, which can mean "shavings" or "waste" (as well as certain types of meat)—for example, "powder of ye offal of golde" (Simpson and Weiner 1989:721). In this case, gold powder was presumably added to the painted surface and decorated in a damask pattern. Unfortunately, this is the only occasion when a royal residence is specified in these bills.

Figure 6  
Bill for the painted furniture executed by Philip Bromefield for Queen Henrietta Maria (U.K. PRO 1632).

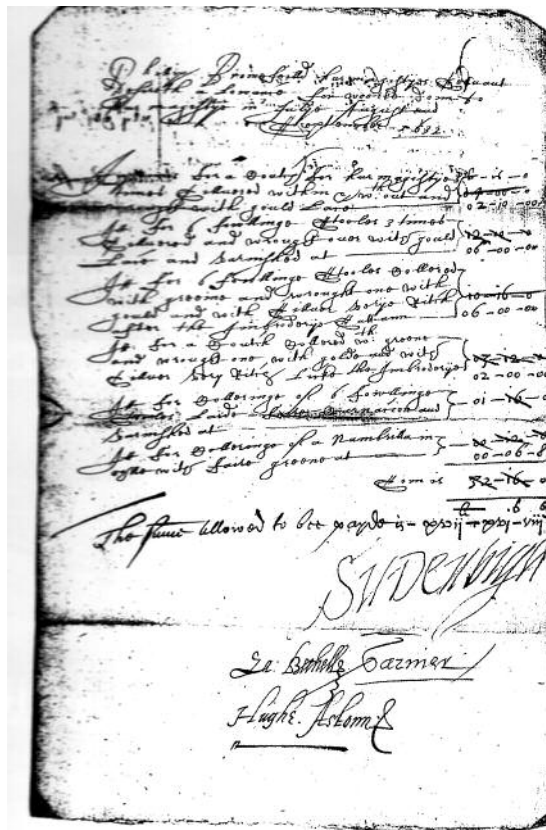



No further work by Bromefield has, to date, been traced. The instances mentioned may be the only occasions on which he painted for the queen. The colors he used (e.g., "tawny," "crimson," and "carnation") may have been fashionable, but owing to a dearth of similar bills and illustrations of this period, one cannot be sure. In portraits of the time—and to a large extent in inventories—the frame is painted merely to match the upholstery. However, the lavishing of lifelike floral decoration on the chairs and trompe l'oeil fluting on the table legs indicates that woodwork was being treated as more than just the framework to support lavish textiles.

Lavishly painted furniture appears in the 1616–18 inventories of Queen Anne of Denmark at the palace (formerly monastery) of Oatlands, Surrey (E.S.C. Record Office 1616:GLY 315; 1617:GLY 319; 1618:GLY 320). It is not known who executed this furniture. It is true that there were chairs, beds, and other upholstered furniture with "frames painted suitably" to match the general color scheme of the textiles (E.S.C. Record Office 1617:GLY 319). However, there was also one suite of stools and chairs with frames "painted with white and gold, spotted with red flowers," and another with "frames painted on a greene ground wth flowers of gold"—both in the queen's cabinet—one with "with red frames painted with red flames on a high ground" in "the Garden Stone Gallery" (E.S.C. Record Office 1616:GLY 315). The mention of "a high ground" suggests that flames may have been painted on built-up gesso. The 1617 inventory includes a field bed, painted red and gold, and a suite of green velvet stools and high chair with frames painted "on a greene ground wth flowers of gold, in ye [unspecified] Bedchamber," presumably decorated like the red and gilded chairs at Knole, Kent. In the North Gallery at Oatlands there was a suite of furniture "painted wth Carnation ground garnished wth flowers"; in the South Gallery there was one "painted with white & gold & spotted with red flowers" (E.S.C. Record Office 1617:GLY 319). It would therefore seem that beds and seating decorated with flowers were befitting to a sovereign or, indeed, to members of the court in the early decades of the seventeenth century. For example, in 1608, Rowland Buckett, a painter of German origins, supplied Robert Cecil, the king's chief minister, with "one grete bedstead with flowers, birdes and personages" (Croft-Murray 1962:164).

The "Inventories and Valuations of the Late King's Goods," compiled by Parliament after the execution of Charles I, include a few examples of painted furniture. Neither Bromefield's nor Queen Anne of Denmark's furniture can be identified with confidence. Nevertheless, one might be tempted to identify Bromefield's "Great French Table" with a table from Denmark (or Somerset) House "painted on ye frame and gilt" bought in 1651 by Nicholas Stone, the former royal sculptor. Denmark House also housed "an Ovall Table of Wallenutt tree painted with silver and other colours" and "Fowre Wooden painted Frames to sett Candlesticks upon valued at £00-04-00." The summer rooms of Oatlands housed "Twelv blewe stooles of wood gilt of ye Italian Table"; these presumably matched the Italian table in style and could well have been *sgabelli*, those richly carved Italian hall chairs that were finding their way to Holland House, Arundel House, or Ham House at this time (Millar 1970–72:57, 113, 118, 287).

It has to be admitted that painted furniture is rarely found among the lists of the king's goods; prominence is given to the lavish textiles that

cover seating, beds, and even cabinets. Nevertheless, if the frames were painted in a “suitable” manner, one might assume that such a fact was not always recorded.

John de Critz of Antwerp, sergeant painter to King James I since 1603 and later to King Charles I, worked extensively for Inigo Jones, executing his stage designs for royal *masques* at Whitehall. Although he seldom painted furniture, he did decorate royal carriages—or *carroches*, as they were called. In 1629 he was paid £80 for painting what must have been a spectacular “carroch wth fine gold and cullors the pannells being painted wth statues and for painting and gilding one cheire and working and painting Antiques on the pannells” (U.K. PRO 1628–29:148). It is to be regretted that this splendid object has not survived; the liberal use of classical ornament very much reflects the king’s cosmopolitan tastes, and suggests that Inigo Jones played a part in designing it.

The bills of Philip Bromefield are among the earliest known that concern the painting of furniture in England. Such documents are mostly confined to royal accounts, but one should remember that before the English Civil War (1642–45), lacunae in the records abound. Mentions in inventories of the sixteenth and seventeenth centuries are rare, as are illustrations. The frames of chairs that feature in portraits of those times, for example, would seem more often to have been covered with dyed cloth than painted. Few examples of painted furniture have survived, but in their time they were regarded as important; they proudly stood in state apartments—not just in garden buildings. Too little research has been done on French furniture of the early seventeenth century for one to know how fashionable painted floral decoration on chairs was at the court of Louis XIII. However, such embellishments could not have been regarded as provincial and peculiar to England. If this had been so, Queen Anne of Denmark and Queen Henrietta Maria would have thought them unsuitable for their state apartments, and they would not have paid high prices for them. As in the case of King Charles’s *carroch*, elaborate painted decoration enhanced the king’s dignity, and the artist was well paid. Although a minor manifestation of kingly splendor, painted furniture is worthy of note and—in the case of Queen Henrietta Maria—comparatively well documented.

---

## Acknowledgments

The author is most grateful to the U.K. Public Record Office for granting permission to publish the bills in Figures 2 and 6, and to Lucy Wood, curator of decorative arts at the Lady Lever Art Gallery, for alerting him to the documents at the East Sussex County Record Office.

---

## References

- Collaert, A.  
ca. 1590 *Florilegium ab Hadrian Collaert et a Philippo Gallaeo Editum*. Antwerp: P. Gallaeus.
- Croft-Murray, E.  
1962 *Decorative Painting in England, 1537–1837*. London: Country Life.
- Jervis, S.  
1974 *Printed Furniture Designs before 1650*. London: Furniture History Society.
- 1989 Shadows, not substantial things: Furniture in the Commonwealth inventories. In *The Late King’s Goods*, ed. A. MacGregor, 277–306. Oxford: Oxford University Press.

- Millar, O.  
1970–72 The inventories and valuations of the king's goods. *Journal of the Walpole Society* 43:1–458.
- Painter Stainers' Company Court Minutes  
1623–49 Guildhall Library, ms. no. 5667/1.
- Simpson, J. A., and E. S. C. Weiner  
1989 *The Oxford English Dictionary*. 2d ed., vol. 10.
- U.K. Public Record Office (PRO)  
1628–29 Michaelmas 1628–Michaelmas 1629. *Lord Chamberlain's Papers*, LC 5/38. London.
- 1630 Philip Bromfield [sic], her Mat's Gilder prayeth allowance for divers calls of worke made and provided for Her Mat's Service synce the first of October 1630 to the last of December 1630. *Land Register Papers*, LR 5/64 (October–December 1630). London.
- 1632 Philip Bromefeild [sic] her Magistyes Servant Desireth allowance for worke donn for Her Magistye in July, August and September 1632. *Land Register Papers*, LR 5/65 (July–September 1632). London.
- 1635 Phillip Bormeifield [sic] her Ma.ties gilder Desyreth Allowance for worke done for her Ma.tie the 3rd of August 1635. *Land Register Papers*, LR 5/66. London.
- 1639 Phillip Bromfield [sic] her Ma.ties gilder deyreth Alloowance for work done for her Ma.tie the 28th Julye 1639. *Land Register Papers*, LR 5/67. London.
- U.K., East Sussex County (E.S.C.) Record Office  
1616–18 Inventories of hangings, carpets, furniture and pictures belonging to the king and queen at Oatlands. *Glynde Place Records*, GLY 315–20. Lewes.

# Perished Perches: The Evidence for English Painted Wooden Furniture in Eighteenth-Century Gardens

Elizabeth White

SUFFICIENT PAINTED WOODEN FURNITURE survives from fashionable eighteenth-century interiors for us to know that it formed a substantial and specific contrast to the well-known corpus of walnut, mahogany, and satinwood (Macquoid and Edwards 1927:27–28). The place of painted furniture in the English vernacular tradition is also increasingly studied (Gilbert 1991); however, extremely little of it actually survives in situ in eighteenth-century gardens.<sup>1</sup> Made of woods susceptible to the ravages of woodworm, time, and the English climate, these pieces tended to be replaced by more durable cast-iron furniture in the nineteenth century. Consequently, extremely few datable pieces exist today; and where they do, they are unlikely to be in original condition. A more durable wrought-iron garden chair of around 1800, now in the Victoria and Albert Museum, has revealed thirty-five layers of paint under the microscope.<sup>2</sup>

Given such a catalogue of disasters, evidence for these “perished perches” must be interpreted through contemporary illustrations, inventories, and the extensive eighteenth-century literature on gardening, as well as the remarkable number of published furniture designs that proliferated from around 1750 and encapsulated the ephemeral spirit of Rococo garden ornament. This article was written with the intention of gathering and quantifying some of the available evidence, with a particular focus on the significance of those Rococo designs.

The decades from 1720 to 1780 were ones of fast-moving development in English furniture and of total revolution in garden design and construction. A correspondent to “Common Sense” in the *Gentleman’s Magazine* (1739:640) wrote:

Every man now, be his fortune what it will, is to be doing something at his place, as the fashionable phrase is, and you hardly meet with anybody who, after the first compliments, does not tell you that he is in Mortar and Moving of Earth—the modest terms for building and gardening. One large room, a serpentine river and a wood are become the absolute necessities of life, without which a gentleman of the smallest fortune thinks he makes no figure in his country.

Whether for early-eighteenth-century formal parterres or for the arranged circuit—or “route through nature” of the picturesque garden—resting points were designed to offer sunlight or (more advisedly) shade, the chance to admire a scenic view, take tea and other refreshments, or

explore the charms of any number and variety of ornamental buildings in order to experience the full range of romantic sensibility.

This enthusiasm for ornamental garden buildings became so intense that Richard Cambridge was induced in 1756 to record former, easier days (Honour 1961:154):

when the price of haunch of venison with a country friend was only half an hour's walk on a hot terrass, a descent into two square fishponds overgrown with frogspawn, a peep into a hogsty or a visit to the pigeon house. How reasonable was this, when compared with the attention now expected from you to the number of temples, pagodas, pyramids, grottoes, bridges, hermitages, caves, towers etc.

Chairs, benches, stools, and tables were provided for the garden and its decorative buildings in as great a variety as they were for the house and were given the same degree of attention in their design, construction, purpose, and finish. Some were made of stone, marble, slate, or wood with a natural finish, and are therefore beyond the scope of this discussion; but a very large number were made of native woods, such as beech and lime, and were painted with oil-based colors, which could afford some protection against the climate and hard use.

The greatest number consisted of seats, but even the description "seat" deserves examination. In the eighteenth century, the word could describe anything from the simplest bench to an elaborate sheltering structure—or could even, of course, refer to the entire country estate.<sup>3</sup> John James's translation of D ezallier d'Argenville's *Theory and Practice of Gardening* (published in England in 1712) included the definition of

Seats, or Benches, besides the conveniency they constantly afford in great gardens, where you can scarce ever have too many, there is such a need for them in walking, look very well also in a garden, when set in certain Places they are destin'd to, as in the Niches or Sinkings that face principal Walks or Vista's, and in the Halls and Galleries of Groves; They are made either of Marble, Free-Stone or Wood, which last are the most common, and of these there are two kinds, the seats with backs to them, which are the handsomest, and are usually remov'd in Winter, and the plain benches, which are fix'd to their place in the Ground.

Canaletto's painting of the Thames as viewed from Richmond House, Whitehall, of 1747, in the Goodwood Collection, affords evidence of garden seats and benches of the d'Argenville types on the "hot terrass"—like that described by Cambridge—in full sun against a west-facing wall (Liversidge and Farrington 1993:70, pl. 12). They are not known to survive, although the Duke of Montagu's painted canvas and wooden chinoiserie tea tent, partly shown by Canaletto next door on the terrace of Montagu House, can still be seen today at Boughton House in Northamptonshire (Bowden-Smith 1988). In this famous painting, Canaletto depicted a pair of formal white-painted settees with scrolled ends and a group of very curious green-painted seats with bench ends and centrally placed open backs and arms, which seem to be fitted to the walls of the landing stage.

The first pair belong to an easily recognizable group of architecturally inspired seats that were probably intended, with their white paint,

to imitate more expensive stone examples, and that provided punctuation marks in the garden—at the ends of avenues, terraces, paths, and pergolas, against contrasting stone walls and dark hedges, and inside classical loggias and temples. They appear in illustrations of seventeenth-century Baroque gardens, in the designs of Daniel Marot in 1703, in Kip’s engravings of English estates, and in 1730s depictions of the formal areas of Burlington’s gardens at Chiswick (Harris 1979; Marot 1703; Atkyns 1712). Thomas Chippendale’s designs in the 1762 edition of the *Gentleman and Cabinet-Maker’s Director* (Fig. 1) specified that the seat “may be placed in walks or at the ends of Avenues,” while an early design by John Soane, dated 1778, also illustrated this type of formal garden seat in the Neoclassical style (Chippendale 1762; Soane 1778:pl. 1).

The pleasure gardens open to the public in and around London in the eighteenth century probably contained many painted seats for the use of customers as they rested during their promenades, took tea or supper, or listened to music. The end of an avenue may have been the original position for one such seat, which carries the date 1763 and was designed by William Hogarth for Jonathan Tyers, proprietor of the Vauxhall Gardens; the seat is depicted there in a 1777 sketch.<sup>4</sup> Its formal design and decoration contrasts with the much more basic tables and chairs that seem to have been used in the supper boxes and can be seen, for instance, in J. S. Muller’s engraving after a view of the Grand Walk by Samuel Wale (ca. 1751).<sup>5</sup> However, the ever-changing schemes at Vauxhall during its most successful years under Tyers and his sons have not left us with any clearer evidence of where this seat actually stood, and it is not known to have survived (Coke 1984:75–98).

There is a close relationship between these formal garden seats and seats for the eighteenth-century entrance hall and banqueting houses, either executed in plain wood or painted in stone colors and bearing the family crest.<sup>6</sup> A further link exists in the use of Windsor chairs for both. The Windsor chairs made for the hall at Enmore Castle, Somerset, of 1756, are decorated all over the surface in checkerwork patterns of red and white paint, and have their full livery of family crest and motto.<sup>7</sup> Many plainer Windsors, painted or unpainted, appear in eighteenth-century inventories for halls, passages, lobbies, and stairwells, available to be carried out to the courtyard, terrace, or lawn for use on fine days.<sup>8</sup> Some were equipped with “skis,” or flat battens running from the front to back feet, to prevent them from sinking into the grass, and others were mounted on small platforms with wheels for children and people with disabilities.<sup>9</sup>

Figure 1  
“Designs for Garden Seats.” Plate 24 from  
*The Gentleman and Cabinet-Maker’s Director*  
(Chippendale 1762).

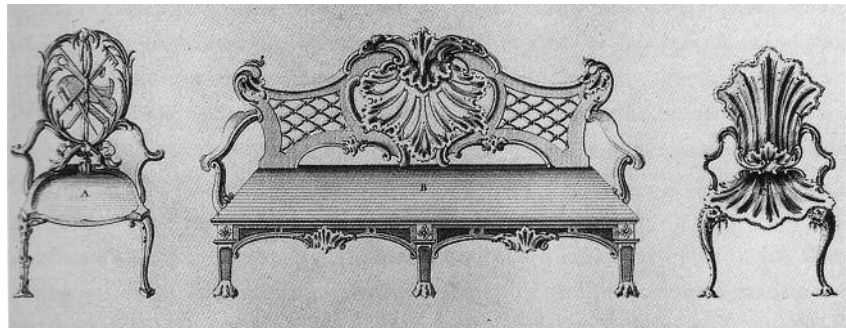

By far the largest number of Windsor chairs and settees depicted in eighteenth-century English gardens or landscapes by contemporary artists were painted green, although other pigments are found on many pieces that have survived, though not necessarily with their original garden locations (Evans 1979; Cotton 1990:42–44). One of Oliver Goldsmith's Windsor chairs is now in the Victoria and Albert Museum; under its current top layer of black paint is a green layer, and the chair may well have been used in his London garden.<sup>10</sup> The history and identification of English Windsor chairs have been discussed extensively elsewhere, and this article can do no more than mention them as the most standard, prevalent, and recognizable garden seats of the eighteenth century. Their sterling performance is renowned in most rooms of the domestic interior, as well as in offices, university common rooms and libraries, surgeries, farmhouses, schoolrooms, church vestries (and as family pews), in shops, ships' cabins, and even in the better class of prison cells (Evans 1979; Cotton 1990:42–44).

One early and very remarkable seat, described as a Windsor, was seen at Dyrham, Gloucestershire, by the plantsman and seedsman Stephen Switzer and recorded in an appendix to his *Ichnographica Rustica* of 1718. High up on the warren was a structure "called a Windsor Seat, which is so contriv'd as to turn round any way, either to take advantage of the prospect, or to avoid the inconveniencies of Wind, the Sun etc.," but there is no mention of painted decoration. However, at the end of the terrace to the northeast of the house were "large arch'd seats on which are painted Motto's suitable to their situation," and the square garden at the center of the wilderness had

four seats at the corners, and a seat round an aspiring Fir Tree in the Centre, from where your Prospect terminates in a large old Church at a very great distance. I never in my whole life did see so agreeable a place for the Sublimest Studies, as this is in Summer, and here are small desks erected in seats for that Purpose.

Below the cascade were two large clipped thorns "encompass'd with seats"; the trunks of the thorns were entwined with green painted lead pipes that "appear more like ivy on rough bark," and that spouted small jets of water at the turn of a stopcock "as natural as if it rain'd" (Switzer 1742:125–26).<sup>11</sup> Johannes Kip's engraving of William Blathwayt's magnificent garden for Sir Robert Atkyns's *Ancient and Present State of Gloucestershire* (Atkyns 1712) is remarkably accurate when used with Switzer's text; taken together, these accounts give a good idea of the variety of garden seats, and their imaginative settings, in the early eighteenth century. Sadly, the formal garden layout at Dyrham was swept away later in the eighteenth century, and these seats have not survived (Mitchell 1978).

Related to the Windsor chairs and settees were a group of simpler "rural" white- or green-painted types with solid or slatted seats and rather delicate open backs, which were fairly portable and often used in conjunction with other light, indoor furniture brought out to the garden for tea parties—the tilt-top or Pembroke table and mahogany parlor chairs. Such a combination can be seen in Arthur Devis's alfresco portrait of Sir Joshua Vanneck's family at Roehampton House, Putney, around 1752 (D'Oench 1980:58, illus. 29).<sup>12</sup>

Figure 2

"A Garden Seat in the Chinese Taste." Plate 38 from *New Designs for Chinese Temples* (Halfpenny 1750).

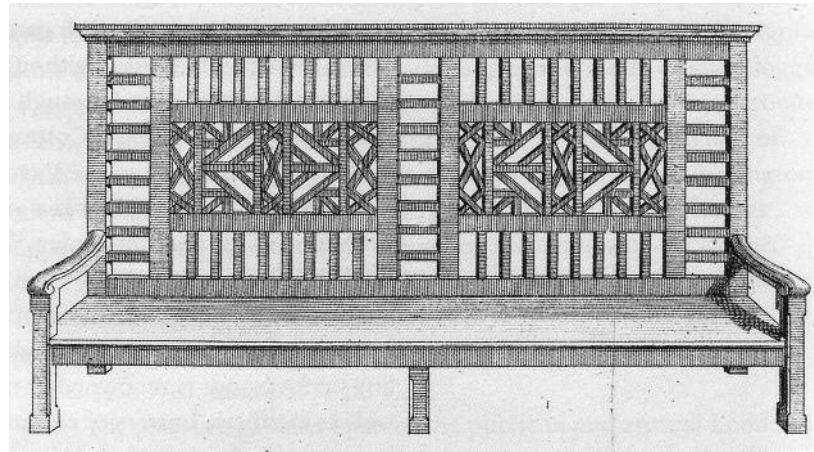

Canaletto's green benches belong to this category—one of considerable inventiveness, if not always of stability—which was very much part of the vernacular English chairmaking tradition before the advent of nineteenth-century cast iron. Many had turned "sticks" for the uprights of their backs and turned legs; these may be the type referred to in some accounts as "forest chairs," denoting either their green paint or rustic design (Evans 1979:29–30).<sup>13</sup> These simple types changed very little in the century between Kip's engravings (Atkyns 1712) and Diana Sperling's watercolors of the garden at Dynes Hall, Essex (ca. 1813) (Mingay and Sperling 1981).

From the 1740s, designs for more sophisticated examples were published to complement the plethora of Chinese railings, trellises, bridges, temples, pagodas, pavilions, Gothic ruins, hermitages, rustic retreats, and grottoes so abhorred by Cambridge, but which gave the "air of whimsical novelty" that pleased Horace Walpole (1973:166) and which can be seen in the illustrations of Thomas Robins (Harris 1978). This was where fashionable designers could let their fancy romp, unrestrained by the disciplines and propriety demanded of them for most indoor furnishing schemes. The architect William Halfpenny's plate for "A Garden Seat in the Chinese Taste" of 1750 (Fig. 2) shows in its rather solid nature an early fusion of the vernacular and the fashionable, which can also be seen in his designs for fences and gates (Halfpenny 1750:pl. 38–40, 46–48). The same may be said of William Pain's design from his *Builder's Companion and Workman's General Assistant* (Pain 1758:pl. 58),<sup>14</sup> and of K. A. Heckel's fine portrait of Charles James Fox (ca. 1793), now in the National Portrait Gallery, London. Fox's massive figure occupies a robust, green-painted settee in the foreground of the painting, with an as yet unidentified landscape in the background.<sup>15</sup>

Printed designs proliferated throughout the 1750s and 1760s, becoming more and more fanciful, exaggerated, and exotic—for instance, in the publications of Edwards and Matthias Darly, Robert Morris, Charles Over, Paul Decker, John Crunden, and Robert Manwaring (White 1990:131–38) (Fig. 3). Some, like the little Chinese pavilions themselves, were brightly painted in a variety of colors—a style condemned by the architect Robert Morris in 1757, although he still included a design for such an enclosed seat: "A good choice of chains and bells, and different

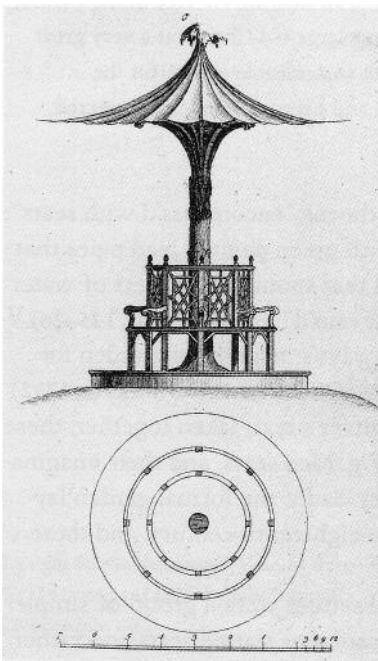

Figure 3

"An Umbrello'd Garden Seat after the Indian Manner." Plate 8 from *Ornamental Architecture in the Gothic, Chinese, and Modern Taste* (Over 1758).



colours of paint . . . a few laths nailed across each other, and made black, red, blue, yellow, or any other colour, or mixed with any sort of chequer work, or impropriety of ornament, completes the whole” (Morris 1971:41). Chippendale’s higher quality designs for Chinese chairs were, as the author wrote, “suitable for both Ladies’ Dressing Rooms and Chinese Temples”—another example of the indoor/outdoor exchange (Chippendale 1762: pl. 26, 28). Linnell’s designs for polychrome “Chinese Chairs” for the bed-chamber at Badminton House, Gloucestershire (ca. 1752), also give an idea of the multicolored style fashionable in the middle decades of the century (Hayward and Kirkham 1980:106–109, pl. 4).<sup>16</sup>

Any discussion of eighteenth-century paint colors used on garden furniture must be related to similar treatment of other woodwork and, in particular, the fences, trellises, and gates that complemented the garden. White paint had been used extensively to highlight the formal fences, railings, and seats of the early-eighteenth-century Baroque garden,<sup>17</sup> and again for the trellises and “thin, fragile bridges of the Chinese” (Knight 1794:33). In 1766, Lady Mary Coke noted in her journal that “as soon as dinner was over I went out, order’d the reparation of all the old broken benches and a quantity of white paint with which I propose to new paint all the seats in the garden” (Coke 1970:42).

Combinations of white and green, and various shades of green, seem to have been more popular than multicolors in the 1760s, indicating the inexorable progress of the picturesque. Plates 29 and 30 of Manwaring’s *Cabinet and Chair-Maker’s Real Friend and Companion* show “two very grand and superb designs for Rural Garden Seats, the ornamental parts should be painted green, and shaded as expressed in the Plate, which will appear extremely beautiful.” Plates 31 and 32 are, Manwaring suggests, “in the Gothic taste; they will look very genteel painted white intermixed with green,” while plates 24–28 are, he claims, “ten very curious and beautiful designs of Rural Chairs, intended to be placed in summer houses, Temples &c., and are the only ones of this kind that ever were published. . . . there are landscapes introduced in some of them, which are intended to be painted,” while the other ornaments “may be painted green, and will look very genteel” (Fig. 4) (Manwaring 1765).

Figure 4  
“Rural Chairs for Summer Houses.” Plate 24  
from *The Cabinet and Chair-Maker’s Real Friend  
and Companion* (Manwaring 1765).

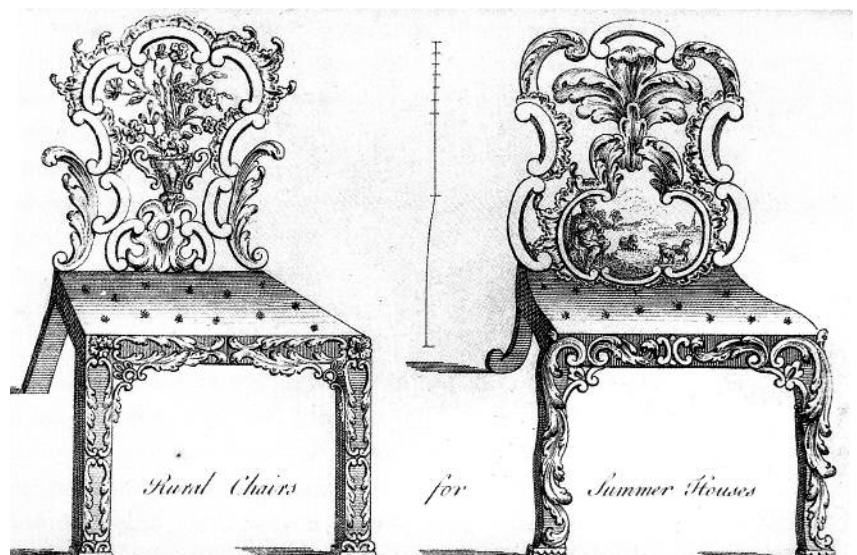

Surviving examples of the green-and-white color combination on chairs include one made for the Chinese temple erected at Stratford-upon-Avon for the Shakespeare jubilee of 1769, organized by David Garrick.<sup>18</sup> This chair is tentatively attributed to Thomas Chippendale (Gilbert 1978, 1:240, 2:pl. 136), but was derived from a design published by Matthias Darly (ca. 1751:pl. 3) and republished by Manwaring (1766:pl. 39). Another surviving example is a set of chairs (ca. 1775) with cane backs and seats, at Osterley Park, Middlesex.<sup>19</sup> The use of these specific colors may express Jean-Jacques Rousseau's admiration of the simple, "natural" life visualized by him in *Emile*, published in 1762, which was so widely read in England: "I would have a little rustic house—a white house with green shutters—on the slope of some agreeable, well-shaded hill" (Rousseau 1979:351).

By the 1770s, a more definite appreciation can be detected of the "camouflaging effect" of green paint alone in the natural garden. William Mason (1724–97) wrote a highly influential poem, "The English Garden" (1777:44–5), that dwelled at length on the aesthetics of the invisible fence:

Let those, who weekly, from the City's smoke,  
Crowd to each neighb'ring hamlet, there to hold  
Their dusty Sabbath, tip with gold and red  
The milk-white palisades, that Gothic now,  
And yet now Chinese, now neither, and yet both,  
Chequer their trim domain. Thy Sylvan scene  
Would fade, indignant at the tawdry glare.  
'Tis thine alone to seek what shadowy hues  
Tinging thy fence may lose it in the lawn;  
And these to give thee Painting must descend  
Ev'n to her meanest Office; grind, compound,  
Compare, and by the distanc'd eye decide.  
For this she first, with snowy ceruse, joins  
The ochr'ous atoms that chalybeate rills  
Wash from their mineral channels, as they glide  
In flakes of earthly gold; with these unites  
A tinge of blue, or that deep azure gray,  
Form'd from the calcin'd fibres of the vine;  
And, if she blends, with sparing hand she blends,  
That base metallic drug then only priz'd,  
When, aided by the hurried touch of Time,  
It gives a Nero's or some tyrant's cheek,  
Its precious canker. These with fluent oil  
Attemper'd, on thy lengthening rail shall spread  
That sober olive-green which nature wears  
Ev'n on her vernal bosom  
The paint is spread; the barrier pales retire,  
Snatch'd, as by magic, from the gazer's view.

Mason was thus describing a sophisticated mixture of ceruse (lead white), ochre, and blue (probably indigo), in an oil binder, to produce an "invisible green" for which many recipes were to be written down and published in the later eighteenth and early nineteenth centuries.<sup>20</sup> The standard, simple, and cheapest mixture of pigments for green oil-based garden paint was that of yellow ochre and lamp black.

Horace Walpole, who knew and corresponded at length with Mason, had plain green-painted furniture in the garden at Strawberry Hill, Twickenham; the accounts for Strawberry Hill mention green-painted garden benches in 1754 and 1775 (Toynbee 1927:5). However, the most famous of Walpole's garden furniture was the "shell bench," which was designed by Bentley,<sup>21</sup> carved by Robinson in 1754, and placed "at the end of the winding walk" at Strawberry Hill. This was where he so admired the picturesque sight of the beautiful Countess of Ailesbury and her daughters the Duchess of Richmond and the Duchess of Hamilton, sitting there in 1759 (Walpole 1973:85, 87). There is no mention of the bench's finish; as an oak piece, it may well have been left in its natural state, but it was still in situ thirty years later (Walpole 1784).

Walpole's use of the shell bench against a tree shows that it was not restricted to the decoration only of grottoes but, through its association with Venus, could be applied to rather intimate arbors above ground—seen earlier, for instance, in John Carwitham's illustration of a shell seat (Reynolds 1740:468). For grottoes, Chippendale published a design in the third edition of the *Director* (1762:pl. 24), but the shell was also used in hall chair design by many of the midcentury publishers, where, once again, a painted finish was an acceptable alternative to mahogany (White 1990:124–28; Hayward 1984).

Walpole's shell seat, if left in its natural finish, may also provide a link with the increasing use of unpainted wood for rustic seats in the picturesque garden. One truly remarkable example survives at Badminton, Gloucestershire, attached to the side of the hermitage designed by Thomas Wright of Durham (ca. 1750), and designs published by Wright (1755) show the "Wizard of Durham's" imaginative use of these rustic themes. Chippendale picked up the theme in a design for a garden chair in plate 24 in the 1762 edition of the *Director*: it has conventional Rococo arms, a back composed of carved leaves and gardening tools, a dished "Windsor-type" seat, and one leg carved to resemble a rough branch. More rustic designs were published by Manwaring in the *Companion* (1765), with instructions about a painted finish. Those illustrated in his plates 26 and 27



Figure 5  
"A Garden Chair." Plate 86 from *A New Book of Chinese Designs* (Darly and Edwards 1754).

may be made with the limbs of yew or apple trees, as nature produces them; but the stuff should be very dry, and well season'd: after the bark is peeled clean off, chuse for your pitches the nearest pieces you can match for the shape of the Back, Fore Feet and Elbows. . . . they are generally painted in various colours.

These "branch" chairs may be compared with the slightly older designs, first published by Matthias Darly in 1754, for "root" furniture (Fig. 5), inspired by the images seen on Chinese polychrome export porcelain of the 1730s in both brown and green (Darly and Edwards 1754:pls. 37, 66, 86, 117). In the entry for 29 May 1777, the accounts for Strawberry Hill include one "for a green root bench for the cottage garden, £2-0-0" (Toynbee 1927:50, 76).

Thus "natural" colors and designs became increasingly desirable in the picturesque garden. By 1785, English readers were aware of the "straw chair" in which Rousseau sat shortly before he collapsed and died in 1778 at Girardin's picturesque garden at Ermemonville, and of the

“elbow” chair made by Rousseau himself. It was formed of rude, unfashioned twigs, interwoven and grafted, as it were, into the tree, which served as a back to it” (Girardin 1982:50, 76).

Certainly by the end of the century the completely “natural look” for garden seats in the context of the Cottage Ornee was fully accepted. Edmund Bartell (1804:25) wrote of trelliswork, railings, bridges, and gates that were “generally painted white or green, which . . . is foreign to every principle of harmony; and although every thing that is slovenly offends and ought to be avoided, we ought equally to avoid a dressed appearance, which would destroy the connexion that should ever subsist between the house and the grounds.”<sup>22</sup> The visual expression of this appeared in designs of all sorts of domestic furniture in an anonymous book titled *Ideas for Rustic Furniture*, published by I. & J. Taylor (1790–95), and in Middleton’s plate 46 of six designs from *The Architect and Builder’s Miscellany*, 1799 (White 1990:144–46; Heckscher 1975:pl. 128–48). A set of chairs now in the Victoria and Albert Museum, which are carved in beech in imitation of twigs, covered in gesso and painted brown, may date from around this time or even later, and may indeed be French.<sup>23</sup>

Finally, some other Rococo designs need to be discussed in relation to two famous paintings (ca. 1750) showing green-painted garden settees. In 1766, Manwaring’s designs were included in, and his name given to, a third volume titled *The Chair-Maker’s Guide* published by Robert Sayer, but which also included plates first published in 1750–51 by Henry Copland and some by Darly, presumably just after the expiration of their original fourteen-year copyright (Paulson 1965). Darly’s influence in the English Rococo is complex and pervasive; although he was a freeman of the Clockmakers’ Company, his other professional activities included designing, engraving, and wallpaper making and selling; he was also a caricaturist and a publisher (Jervis 1984; White 1990:40).

The designs for parlor chairs of around 1751, originally issued by Darly as *A Second Book of Chairs*, were reissued as plates 41, 42, 44, 45, and 54 in Manwaring’s 1766 *Chair-Maker’s Guide* and have now been attributed to Darly by Christopher Gilbert (1975:33–39, pl. 74–78) and Simon Jervis (1984). They are characterized by flat, scrolling, interlaced patterns for their backs in the manner of De La Cour and are seen frequently in parlor chairs executed in mahogany, and in interior portrait settings, book illustrations, sketches, and engravings by Francis Hayman, Hubert Gravelot, and others of the Saint Martin’s Lane artistic set.<sup>24</sup>

A green-painted version of Darly’s design can be seen in Francis Hayman’s portrait of Mr. and Mrs. George Rogers, *Margaret Tyers and Her Husband George Rogers* (ca. 1750), now in the Mellon Collection (Allen 1987:46, pl. 5, cat. no. 25). It has a distinctive sweep to the visible arm of the settee and is another example of how freely designers and makers adapted indoor furniture patterns for outdoor purposes. Margaret Rogers was the daughter of Jonathan Tyers, proprietor of the Vauxhall Gardens and friend of Hogarth, Hayman, Roubiliac, and Gravelot (Coke 1984:75–98).

Plates 69–75 of Sayer’s *Guide* have recently been identified as reissues of *Six New Designs of Chairs*, printed in 1753 for John Smith, a map and print seller in Cheapside (Gilbert 1993). When Sayer reissued these plates in *The Chair-Maker’s Guide*, 1766, under the authorship of Robert Manwaring, he added the title “Summer House Chairs,” renumbered the

plates, and slightly altered some of the legs. Although curious to look at, these plates—especially the title page of Sayer’s 1753 edition (Manwaring 1766:pl. 70)—inspired a number of chair carvers.

Plate 47 of the *Guide*, at present unattributed, is a design for an elaborate garden settee with a finely proportioned, scrolling Rococo back in the Darly-Smith tradition (Fig. 6). Its design immediately recalls that most memorable of images of eighteenth-century garden seats—Gainsborough’s double portrait of *Mr. and Mrs. Andrews*, painted in Suffolk after their marriage in November 1748.<sup>25</sup> The composition of the painting is a reverse image of Hayman’s portrait of the Rogers couple, and the bench itself is a sophisticated version of Hayman’s but with the same, if more attenuated, treatment of the scrolling arm and derivative of the designs for root benches. Many suggestions have been made as to whether this seat really existed and has perished or was purely a piece of artistic imagination. If thought to be real, it is now usually described as being made of wrought iron (Cormack 1991:46, no. 8). But on the strength of Hayman’s portrait, so close in date to Gainsborough’s (ca. 1750), and based on the rest of the evidence that this article has hopefully clarified—the Darly and Darly-esque furniture designs of 1750–54, the variety and vigor of the wood-carver’s and designer’s oeuvre at this time, the extensive use of Mason’s “fluent oil” (that is, the green paint on garden woodwork)—and based on the lack of evidence for a parallel sophisticated wrought-iron furniture industry, this author is convinced that this most memorable of perches, perished or illusory, must belong firmly within the painted wood tradition.

In conclusion, therefore, the evidence currently available shows the extensive use of paint on eighteenth-century garden seats to provide both protective coatings on softwoods and decorative treatments following current fashions in garden design and ornament. The fashionable use of various colors during the middle of the century gave way to the simple use of green, or white and green, during the 1760s; complete naturalism in the use of “invisible” green, or just natural wood, was most prevalent by the end of the century. The study of contemporary pattern books,

Figure 6  
“Garden Seat.” Plate 47 from *The Chair-Maker’s Guide* (Manwaring 1766).

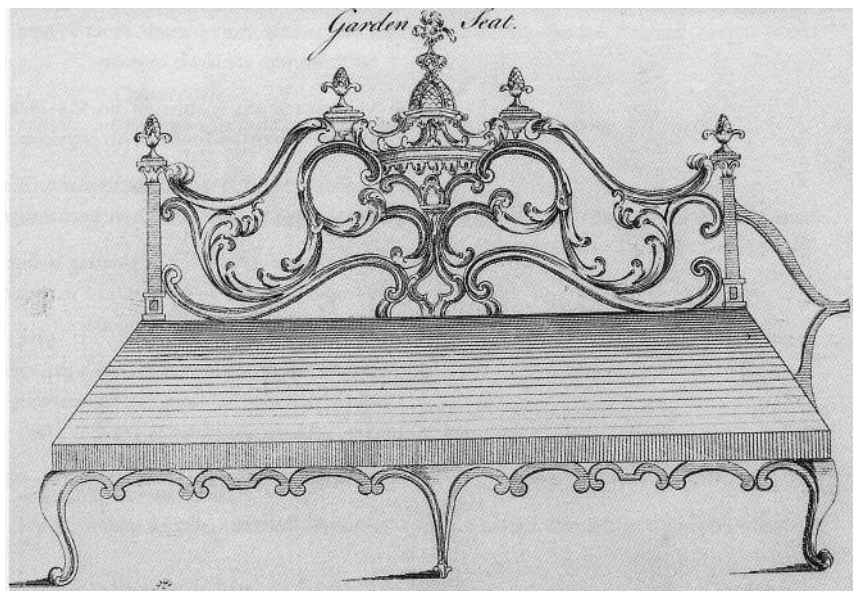

accounts, literature, conversation, and landscape pieces extends our knowledge of a subject where few surviving objects can be used for research. Such study may assist us in the identification of yet rarer survivors, as well as in their correct conservation.

---

## Acknowledgments

The author would like to thank the following for their assistance in the preparation of this chapter: Clive Wainwright, senior research fellow, Victoria and Albert Museum; Rosalind Savill, director, The Wallace Collection, London; John Hardy, Christie's; Francis Greenacre and Sheena Stoddard, Bristol Museum and Art Gallery; and Christopher Wilk and his staff in the Furniture and Woodwork Collections of the Victoria and Albert Museum, London, who generously provided access to the departmental files.

---

## Notes

- 1 One recent discovery by the Avon Gardens Trust is of a seat, probably designed by William Kent, ca. 1740, for a garden at Cleeve on the outskirts of Bristol, which is now suburbanized; the seat is covered in many layers of paint, including modern gloss.
- 2 Victoria and Albert Museum, no. W.11–1977. The report on paint by Jo Darrah, 3 March 1977, lists seventeen layers of green, eight of white, three or four of brown, and three of gray paint, with the possibility of some undercoats.
- 3 *Shorter Oxford English Dictionary*, 1933, s.v. "seat."
- 4 This sketch is housed in the Department of Prints and Drawings, British Museum, London.
- 5 Museum of London, no. 5352/7. Discussed in Coke (1984:88).
- 6 For example: Badminton House, Gloucestershire, North Hall and Sherborne, Gloucestershire (designed by James Moore).
- 7 Victoria and Albert Museum, no. W.34–1976. Some doubt has been expressed about the authenticity of these chairs, but see Cornforth (1991:98); also Shore (1789), who notes that "the walls are covered with family busts and coats of arms; painted chairs of the same etc.;" and Collinson (1791:89–96).
- 8 "Eight mahogany Windsor Elbow Chairs" are listed in Rosomon (1986:99).
- 9 Tradecard of William Webb (ca. 1785), Department of Prints and Drawings, British Museum, London. See also the *Gentleman's Magazine*, April 1746, for a design for a wheelchair "in which a person may move himself about a room, or garden, without any assistance; very convenient for those who are lame, or gouty."
- 10 Victoria and Albert Museum, no. 538–1872. This chair is made of ash and was bequeathed in 1774 by Oliver Goldsmith to his physician, William Hawes, founder of the Humane Society.
- 11 Defoe (1974:i.303) recorded a similar turning seat at the end of the great terrace at Windsor in 1724, which he believed to have been designed by Queen Elizabeth I.
- 12 See Webster (1976:47). The painting is described as "Conversation Piece: William Ferguson introduced as heir to Raith, 1769," in the collection of A. B. L. Munro Ferguson of Raith and Novar, National Gallery, London.
- 13 On the top of the Mount at Pope's garden in Twickenham, Surrey, stood "a Forest Seat or Chair, that may hold three or four persons at once, overshadowed with the branches of a shading tree" (*Epistolary Description* 1747).
- 14 For more on Pain, see Harris (1990:338–46).
- 15 National Portrait Gallery, London.

- 16 Traces of the original polychrome scheme have been found under the early-nineteenth-century black-and-gold japanning on chairs from the set now divided between the Bristol Museum and Art Gallery and the Victoria and Albert Museum (nos. W.33, 34–1990).
- 17 See Harris 1979, plate 14 (View of Denham Place, Buckinghamshire, ca. 1705), which shows the use of white paint.
- 18 For Garrick's green-and-white painted indoor furniture, see Galbraith (1972:47) and nos. W.21–32–1917 in the Department of Furniture at the Victoria and Albert Museum.
- 19 Green-painted chairs are listed in Tomlin (1986:126–27) for the Semicircular Greenhouse, Great Greenhouse, and Summer House; green-and-white ones are listed for the parlor of the menagerie; and the tent in the park was lined with green tammy.
- 20 Full details of which are to be published by Ian Bristow in his forthcoming monograph on historic paint colors. The author is grateful to Bristow for his generous gift of information before publication.
- 21 Bentley's design is now in the Walpole Library, Yale University.
- 22 "A coat or two of drying oil" was sufficient for the protection of natural wooden furniture and fittings (Bartell 1804:48).
- 23 Victoria and Albert Museum, nos. W.61–66-1952. Notes in Departmental Catalogues, Furniture and Woodwork Collections. They may well date from later in the nineteenth century if they did indeed come from Bagatelle just before Sir Richard Wallace's tenure. Further investigation of them would be welcomed.
- 24 For these designs by De La Cour, see White (1990:59–61); and De La Cour (1741). For other illustrations of this type of chair, see Allen (1987:25, 126).
- 25 National Portrait Gallery.

---

## References

- Allen, B.  
1987 *Francis Hayman*. New Haven, Conn. and London: Yale University Press.
- Atkyns, Sir Robert  
1712 *The Ancient and Present State of Gloucestershire*. London.
- Bartell, E.  
1804 *Hints for Picturesque Improvements in Ornamented Cottages, and their Scenery . . .* London: printed for J. Taylor, Architectural Library, High Holborn.
- Bowden-Smith, R.  
1988 *The Chinese Pavilion, Boughton House, London*. Woodbridge, England: Avenue Books.
- Chippendale, T.  
1762 *The Gentleman and Cabinet-Maker's Director*. 3d ed. London.
- Coke, D.  
1984 Vauxhall Gardens. In *Rococo: Art and Design in Hogarth's England*, ed. Michael Snodin, 75–98. Exhibition catalogue, Victoria and Albert Museum. London: Trefoil Books.
- Coke, M.  
1970 *The Letters and Journals of Lady Mary Coke*. Vol. 1, 1756–67. Bath: Kingsmead Press.
- Collinson, J.  
1791 *The History and Antiquities of Somerset*. Bath.
- Cormack, M.  
1991 *The Paintings of Thomas Gainsborough*. Cambridge: Cambridge University Press.
- Cornforth, John  
1991 Fresh as paint. *Country Life* 185(16):1991–98.

- Cotton, B.**  
1990 *The English Regional Chair*. Woodbridge, England: Antique Collectors' Club.
- Darby, M.**  
ca. 1751 *A New Book of Chinese, Gothic and Modern Chairs*. London.
- Darby, M., and G. Edwards**  
1754 *A New Book of Chinese Designs*. London.
- Defoe, D.**  
1974 *Tour through the Whole Island of Great Britain, 1724–6*. London: J. M. Dent and Sons.
- De La Cour, W.**  
1741 *First Book of Ornament*. London.
- Dézallier d'Argenville, A.-J.**  
1712 *The Theory and Practice of Gardening: Wherein is Fully Handled All that Relates to Fine Gardens, Commonly Called Pleasure-Gardens, as Parterres, Groves, Bowling-Greens &c. . . . Together with Remarks and General Rules in All That Concerns the Art of Gardening*, trans. John James. London: G. James.
- D'Oench, E. G.**  
1980 *The Conversation Piece: Arthur Devis and His Contemporaries*. New Haven, Conn.: Yale University Press.
- Epistolary Description of the Late Mr. Pope's House and Gardens at Twickenham*  
1747 London.
- Evans, Nancy Goyne**  
1979 English Windsor furniture. *Furniture History* 15:24–53.
- Galbraith, L.**  
1972 Garrick's furniture at Hampton. *Apollo* (July):46–55.
- Gentleman's Magazine*  
1739 Common sense. (December):640.
- Gilbert, C.**  
1975 The early furniture designs of Matthias Darby. *Furniture History* 11:33–39.  
1978 *The Life and Work of Thomas Chippendale*. 2 vols. New York: Macmillan.  
1991 *English Vernacular Furniture, 1750–1900*. New Haven, Conn.: Yale University Press.  
1993 Smith, Manwaring, Sayer and a newly-discovered set of designs. *Furniture History* 29:129–31.
- Girardin, René Louis de**  
1982 *A Tour to Ermemonville, containing . . . A Particular Description of the Tomb of J. J. Rousseau, with Anecdotes . . . of that celebrated and singular Man*. London. 1785. Reprint, New York: Garland Publications.
- Halfpenny, W.**  
1750 *New Designs for Chinese Temples*. London.
- Harris, E.**  
1990 *British Architectural Books and Writers, 1556–1785*. Cambridge and New York: Cambridge University Press.



- Harris, J.  
1978 *Gardens of Delight: The Rococo and English Landscape of Thomas Robins the Elder*. London: Basilisk Press.
- 1979 *The Artist and the Country House: A History of Country House and Garden View Painting in Britain, 1540–1870*. London: Sotheby Parke Bernet.
- Hayward, H.  
1984 Enterprising craftsmen. *Country Life* 175, no. 4530(June 14):1678–80.
- Hayward, H., and P. Kirkham  
1980 *William and John Linnell, Eighteenth-Century London Furniture Makers*. Vol. 1. New York: Rizzoli and Christie's.
- Heckscher, M.  
1975 Eighteenth-century rustic furniture designs. *Furniture History* 11:59–65.
- Honour, H.  
1961 *Chinoiserie: The Vision of Cathay*. London: J. Murray.
- Jervis, S. S.  
1984 *Dictionary of Design and Designers*. London: Penguin Books.
- Knight, Richard Payne  
1794 *The Landscape: A Didactic Poem*. Bk. 2. London.
- Liversidge, M., and J. Farrington, eds.  
1993 *Canaletto and England*. London: M. Holbertson and Birmingham Museums and Art Gallery.
- Macquoid, P., and R. Edwards  
1927 *The Dictionary of English Furniture*. Vol. 3. London: Country Life.
- Manwaring, R.  
1765 *The Cabinet and Chair-Maker's Real Friend and Companion*. London.  
1766 *The Chair-Maker's Guide*. London.
- Marot, D.  
1703 *Nouveaux fauteuils*. Amsterdam.
- Mason, W.  
1777 *The English Garden*. Bk. 2. London.
- Mingay, G., and D. Sperling  
1981 "Mrs. Hurst Dancing" and Other Scenes from *Regency Life, 1812–1823*. No. 54, "Harry Rochfort playing his flute." London: Gallancz.
- Mitchell, A.  
1978 The park and garden at Dyrham. In *National Trust Yearbook*, 83–108. London: Sotheby Parke Bernet.
- Morris, R.  
1971 *The Architectural Remembrancer*. 1751. Reprint, Farnborough, England: Gregg Publications.
- Over, Charles  
1758 *Ornamental Architecture in the Gothic, Chinese, and Modern Taste*. London.

- Pain, W.**  
1758 *Builder's Companion and Workman's General Assistant*. London.
- Paulson, R., ed.**  
1965 *Hogarth's Graphic Works*. H. Walpole (?), n.d. Reprint, New Haven, Conn.: Yale University Press.
- Reynolds, John**  
1740 *History 29 of God's Revenge against Murder, remarkably display'd in Thirty Tragical Histories . . . Each History Introduced with a Copper Plate of the Principal Passages*. 8th ed. London.
- Rosomon, T.**  
1986 The 1770 inventory of Chiswick House. *Furniture History* 22:81–106.
- Rousseau, J.-J.**  
1979 *Emile, or, On Education*. Trans. A. Bloom. Bk. 4. Originally published as *Emile, ou De l'Education*, Paris: Librairie Larousse, 1762. Reprint, London: Penguin Books.
- Shore, S.**  
1789 *A Tour to the West of England . . . taken in 1788*. London.
- Soane, Sir John**  
1778 *Designs in Architecture*. London.
- Switzer, Stephen**  
1742 *Ichnographia Rustica; or, The nobleman, gentleman, and gardener's recreation*. 2d ed. Vol. 3. London: D. Brown.
- Tomlin, M.**  
1986 The 1782 inventory of Osterly Park. *Furniture History* 22:126–27.
- Toynbee, P., ed.**  
1927 *Strawberry Hill Accounts: A Record of Expenditure in Building, Furnishing &c kept by Mr. Horace Walpole from 1747 to 1795*. H. Walpole, n.d. Reprint, Oxford: Clarendon Press.
- Walpole, Horace**  
1784 *A Description of the Villa of Mr. Horace Walpole*. London.  
1973 *Selected Letters of Horace Walpole*. Vol. 20, ed. W. S. Lewis. New Haven, Conn.: Yale University Press.
- Webster, M.**  
1976 *Johan Zoffany*. Exhibition catalogue no. 42. London: National Portrait Gallery.
- White, E.**  
1990 *Pictorial Dictionary of British 18th Century Furniture Design*. Woodbridge, England: Antique Collectors Club.
- Wright, T.**  
1755 *Universal Architecture, Book I: Six Original Designs of Arbours*. London.

# Shaker Painted Furniture

## Provocative Insights into Shaker Paints and Painting Techniques

*Susan L. Buck*

**T**HIS RESEARCH WAS INSPIRED by a request from the owners of the Mount Lebanon Shaker Collection for help in interpreting the paint history of four Mount Lebanon objects that appeared to have been stripped and revarnished. In 1930, the majority of the buildings and land owned by the Mount Lebanon community (the Shaker spiritual center) were sold and soon after became the site of the Darrow School. At its peak in about 1860, the population in Mount Lebanon was almost six hundred. The Darrow School purchase included forty buildings—some quite massive in size—and all the furnishings in those buildings.

Over the years, the Darrow School periodically auctioned off its Shaker objects to keep the school solvent. In 1992, the balance of the collection, including the built-in furniture, was sold to a single buyer and became the core of the privately owned Mount Lebanon Shaker Collection. Some of the furniture that came from the Darrow School in this last sale had been badly abused. There were cat scratches on the drawer fronts of counters, student graffiti on the insides of cupboard doors, chemical and paint stains on cupboards used for storage of photochemical and cleaning supplies, and—in two instances—modern synthetic coatings on top of stripped or disk-sanded countertops. Despite the sad condition of some of these objects, there were still remnants of what appeared to be original paint in protected areas and trapped in the wood fibers. This was sufficient material for cross-section analysis and pigment identification to help reconstruct the paint history of these formerly painted surfaces.

This initial study of Shaker paints was intriguing, and it inspired an in-depth examination of similar painted objects from Mount Lebanon that had survived in better condition.

A comprehensive study of the architectural paints in the Canterbury Shaker Village Dwelling House was completed in September 1994 by the author and Alex Carlisle, a student in the University of Delaware/Winterthur Program in Art Conservation. The results of this study were also compared to the evidence found on Shaker painted furniture. Study of Shaker architectural paints is facilitated by the fact that the majority of paint recipes discovered during this research were for architectural paints; and, during certain periods, there are very specific Shaker dictates in the Millennial Laws for the colors of floors, moldings, and exteriors.<sup>1</sup> Large-scale Shaker built-in furniture—such as cupboards, counters, and closets—bridges the gap between furniture and architectural

elements (Fig. 1). These forms were intended to be immovable, but they are constructed with traditional Shaker furniture methods and are often finished like other movable furnishings.

---

## Historical Background

In the 1930s, the simple, beautiful objects produced by the Shakers for their own use became surprisingly fashionable and desirable. This was due, in part, to the closing of several communities as older believers died and the celibate Shaker population dwindled. There was no longer the need for all the beds, cases of drawers, cupboards, tables, candlestands, and desks that had been built to serve the needs of the populous communities in the mid-1800s. As communities closed or were consolidated, many of the material goods were sold to what the Shakers refer to as “the World.” At the same time, the enthusiastic promotional efforts of Edward and Faith Andrews, noted Shaker scholars and dealers, also helped to build a strong market for Shaker objects, which continues to grow.

The early, romanticized vision of the Shakers producing divinely inspired furnishings and textiles has resulted in a considerable amount of misinformation about Shaker craft methods, and about the bright paints used on much of the furniture and in the buildings. One book describes Shaker furniture paint colors as “reflections of the way things were thought to be coloured in heaven” (Horsham 1989:45). Recently, a guide at one of the Shaker villages was overheard telling visitors that the dark blue paint on the woodwork in the Meeting House was made from blueberries and butter-milk. Original painted surfaces are highly desirable in the current market for Shaker furniture and wooden objects, and there are frequent references in auction catalogues to “original milk paint,” “original, untouched chrome yellow paint,” or “traditional red ochre paint.” However, there is no evidence in the literature to date that any analysis has been carried out on Shaker furniture to identify the pigments and binders in these “untouched” paints or to confirm that these objects have not been repainted.

The Shakers put a great deal of emphasis on cleanliness, and there are specific instructions in the 1845 Millennial Laws<sup>2</sup> about caring for and

*Figure 1*

An impressive set of cupboards and drawers built into the Meeting Room in the brick Dwelling House at Hancock Shaker Village, Pittsfield, Massachusetts.

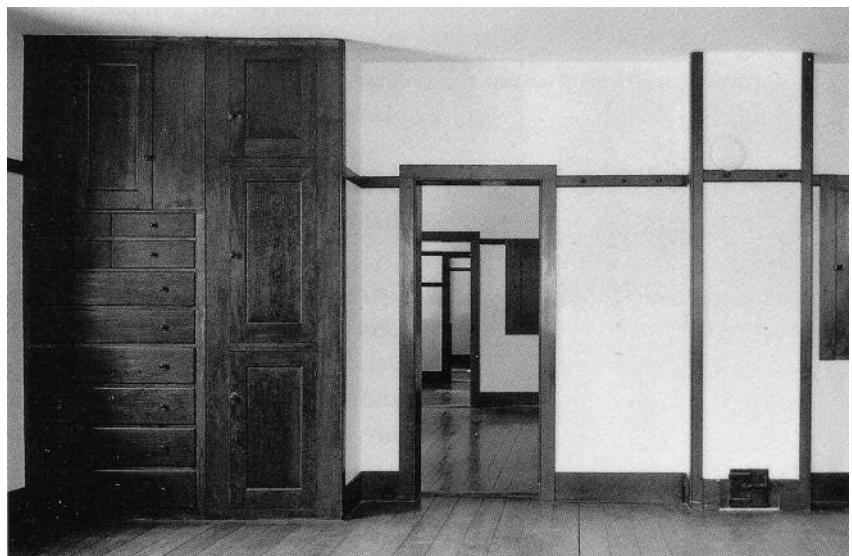

cleaning furnishings, living spaces, and work areas. For example, part 6, “Miscellaneous Rules and Counsels,” rule 29, states: “All should be careful not to mar or destroy the furniture in their shops and rooms.” There also are a number of Shaker recipes dating from the early to late 1800s for cleaning and stripping furniture with caustic solutions, implying that painted and clear-finished surfaces that received regular handling may have been routinely washed, and periodically stripped and recoated, to meet the high standards for cleanliness.<sup>3</sup> A recent study of the paint history of the Dwelling House at Canterbury Shaker Village also revealed large areas of woodwork that had been painted with oil-bound chrome yellow paint during an 1837 addition to the building, and then later mechanically scraped down before being repainted white.<sup>4</sup> The bright yellow paint still survives in the fibers of the wood and is visible under magnification.

Given this Shaker penchant for cleanliness and a cultural emphasis on the highest standards of work—as well as, by the late 1800s, a willingness to adopt the styles and technology of “the World”—it appears unlikely that all the Shaker painted objects believed to have had original surfaces truly were untouched.<sup>5</sup>

---

## Shaker Paint and Varnish Recipes

One invaluable recipe book was discovered during this research. It is a handwritten book titled *Receipt Book, Concerning Paints, Stains, Cements, Dyes, Inks, &c.* On the title page is the inscription: “Rosetta Hendrickson, A Present from Eld. Austin.” Rosetta Hendrickson (1844–1912) lived in the Watervliet, New York, Shaker community until 1865, when she moved to Mount Lebanon, only a few miles from Watervliet. This book is now in the Western Reserve Library and is believed to date from approximately 1848–49.<sup>6</sup> It contains numerous paint and stain recipes, all written in the same hand, with a few citations for sources. Many of the recipes, including the following one for “Sky Blue for New Meetinghouse, Chh. Watervliet (1849),” were quite simple:

### Inside Wash

To 10 #s White Lead, put  
1# Prussian Blue, mixed in Linseed Oil and drying materials.  
For the Meetinghouse doors &c. a little Varnish was added.

Analysis of paint cross sections and pigment samples from moldings of the Canterbury, New Hampshire, Meeting House confirm the use of Prussian blue and lead white in an oil binder with a resin varnish component, and help to disprove the fanciful blueberries and buttermilk theory.

A very detailed “receipt for making and applying the Tere-de-Sena stain” from the same book was found to directly correlate with the scant evidence on an 1860 Mount Lebanon counter made by Benjamin Lyon (1780–1870) and Charles Weed (b. 1831; left the Shakers in 1862). It appeared to have been stripped and refinished, and the evidence indicated the presence of an original oil-bound stain composed of burnt sienna.<sup>7</sup> This counter now has three finishes that were applied later, including what appears to be a polyurethane layer directly on top of the wood substrate. There is a gum sizing in the wood, and the burnt sienna particles are trapped in the wood fibers.<sup>8</sup>

This recipe book helps disprove the commonly held belief that the Shakers had developed their own unique working methods and were using the materials most readily available in an agrarian society. The recipes incorporate traditional paint materials, such as lead white, Prussian blue, Chinese vermilion, verdigris, French yellow (ochre), chrome orange, chrome yellow, linseed oil, and shellac, all of which would have been purchased from outside sources. In fact, at the end of the recipe book there is a list of the materials and quantities purchased for painting the new Meeting House in Watervliet in 1848.<sup>9</sup>

Another intriguing discovery was a recipe for “fat copal varnish” in the Hendrickson book,<sup>10</sup> which was identical in wording to a recipe for fat copal varnish in *Mackenzie’s Five Thousand Receipts* (1829:23), published in Philadelphia. Mackenzie, in turn, reprinted recipes verbatim from *The Painter and Varnisher’s Guide*, published in London at the beginning of the nineteenth century (Tingry 1804:80).

A number of Shaker paint and varnish recipes were discovered in handwritten journals and books containing medicinal, food, and household recipes. It is curious that many of the medicinal and household recipes incorporate common raw materials for paints, and are very similar, or virtually identical, to some of the paint recipes. The following recipe<sup>11</sup> would have produced a rather toxic green salve:

#### **Green Ointment for cuts & wounds**

Hogs lard ½ lb  
 Verdigris one oz Rosin Do  
 Turpentine Do Beeswax Do

A number of the recipes list only the pigments, not the binding media components. A recipe for green paint from Canterbury Shaker Village from Sister Mary C. Whitcher, dated 1863, is titled “To mix paint for outside of houses,” and it contains 125 lb. (56.75 kg) lead white, 6 lb. (2.72 kg) green chrome, 6 lb. (2.72 kg) French yellow, and 2½ lb. (1.13 kg) yellow ochre.<sup>12</sup> All of the exterior architectural paint samples examined in this study were oil-bound, and it seems likely that linseed oil was the primary binding component, as it appears in many other exterior paint recipes.

In addition to raw pigments, linseed oil, and turpentine, alcohol was a major component in “spirit” or alcohol-based varnishes such as shellac. It was also a base for Shaker medicinal herbal extracts, balms, and liniments. One potentially odorous recipe for liniment contains alcohol, turpentine, camphor, hartshorn (a preparation of ammonia used as smelling salts), “beefs gall,” and sweet oil.<sup>13</sup>

Perhaps one-third of the Shaker recipes discovered in the course of this study have citations from such sources as *N.Y. Farmer, Scientific American, The Dictionary of Mechanical Engines and Engineering* (1851), *New York Agricultur, Farmers Cabinet, Boston Journal of Chemistry* (1881), and *Popular Science News*. A recipe titled “Patent Composition for gum shelack” was discovered in an 1881 Shaker community recipe book from Harvard, Massachusetts, which was identical to a recipe in the Rosetta Hendrickson recipe book.<sup>14</sup> It is therefore clear that the Shakers were drawing from numerous sources, including other Shaker communities, and were using proven recipes and materials. They were not inventing their own unique paints and varnishes.

---

## Technical Analysis of Shaker Paints and Raw Materials

Cross-section and pigment samples were taken from more than forty objects from Mount Lebanon; samples from twelve objects from Canterbury Shaker Village, Hancock Shaker Village, and the Enfield, New Hampshire, community—as well as numerous unattributed Shaker objects—have been examined for purposes of comparison.<sup>15</sup> At least three cross sections were taken from representative, protected areas of each object. Additional scrapings from specific paint layers were taken for pigment identification. This sampling is not exhaustive, and is still in progress, yet the results to date are quite revealing. Bottles and packages of raw pigments and resins found in the collections of Hancock Shaker Village in Hancock, Massachusetts, and the Shaker Museum in Old Chatham, New York, were also analyzed to identify the contents.

The cross sections were examined with visible and fluorescent microscopy techniques at  $\times 125$ ,  $\times 250$ , and  $\times 500$ , using biological stains to characterize the binding media. Polarized light microscopy and microchemical testing procedures were employed to identify the pigments in specific paint layers. In addition, selected samples were analyzed at the Center for Conservation and Technical Studies, Harvard University Art Museums, using Fourier-transform infrared (FT-IR) microspectroscopy to study binding media components and to identify certain pigments, and scanning electron microscopy (SEM) to identify elements in the paint layers. The author also worked with Janice Carlson, senior scientist at the Winterthur Museum, to conduct X-ray fluorescence (XRF) analysis for inorganic components, as well as additional FT-IR analysis.

Analysis revealed that virtually all of the wooden objects, with the exception of the green beds, were first sized with a gum priming layer before paint was applied.<sup>16</sup> This gum size would have sealed the wood fibers so the paint would form a more consistent, intensely colored layer on the surface. This means that less of the more expensive pigmented material would be required to produce an evenly painted surface. Despite the use of gum sizes, however, the paints often penetrated deeply into the wood fibers—an indication that there was a low ratio of pigment to binder.

There were surprising variations in the pigment combinations used to achieve specific colors. The pigments listed in Table 1 show, for example, that an intense red color was achieved by a simple combination of red ochre and inert fillers, such as calcium carbonate, or by more complicated combinations of red lead, burnt sienna, and raw sienna.

Chrome yellow was found most frequently in bright yellow paints, usually in combination with iron earth pigments and lead white. Zinc yellow was discovered on only one object: a large cupboard from the Mount Lebanon community. This was one of only two objects painted with what appears to be an egg tempera binder. Yellow ochre was also found in combination with chrome yellow, and it was the primary colorant on the yellow moldings dating from the 1793 construction of the Canterbury Meeting House. The massive built-in closets and drawers on the fourth floor of the Canterbury Dwelling House date to the 1837 addition, and the paint is composed primarily of chrome yellow and lead white in an oil binder. This is very similar to the yellow built-in closets and drawers from the Enfield, New Hampshire, community that are now installed in the Shaker rooms at the Winterthur Museum.

Objects with original blue paint were more difficult to locate, and the search is ongoing. The blue layer on an aqua-colored box in the Winterthur Museum collection turned out to be a second generation of

Table 1 Pigments and binding media components found on Shaker painted objects

Object	Pigments <sup>a</sup>	Binder components
<b>Red paints</b>		
1. Red counter, 1820, ML	red ochre, <sup>b</sup> calcium carbonate fillers <sup>b</sup>	oil <sup>c,f</sup>
2. Red wall cupboard, 1790–1800, ML	red ochre, lampblack, charcoal black	oil, <sup>c</sup> protein <sup>d</sup>
3. Red cupboard, 1840, ML	red ochre, yellow ochre, raw sienna, chrome yellow	oil <sup>c,f</sup>
4. Orren Haskins counter, 1847, ML	red lead, red ochre, burnt sienna, yellow ochre, raw sienna	oil <sup>c,f</sup>
5. Red hanging cupboard, 1830–70, ML	red lead, <sup>b</sup> iron earth pigments <sup>b</sup>	oil <sup>c,h</sup>
6. Benjamin Lyon counter, 1860, ML	red ochre, burnt sienna	oil <sup>c,f</sup>
7. Benjamin Youngs Sr. tall case clock, 1806, WV	none	organic stain in oil <sup>c,h</sup>
<b>Yellow paints</b>		
8. Yellow cupboard, 1840–60, ML	zinc yellow, iron earth pigments	protein <sup>d,g</sup>
9. Interior of red wall cupboard, 1790–1800, ML	chrome yellow, red ochre, burnt sienna	oil <sup>c,f</sup>
10. Interior of Deaconesses cupboard, 1840, ML	chrome yellow, red ochre, iron earth pigments, charcoal black	oil <sup>c,f</sup>
11. Interior of red hanging cupboard, 1830–70, ML	chrome yellow, <sup>b</sup> lead white <sup>b</sup>	oil <sup>c,f</sup>
12. Dwelling Room built-in cupboards and drawers, 1840, EN	chrome yellow, <sup>b</sup> lead white, <sup>b</sup> iron earth pigments <sup>b</sup>	oil <sup>c,h</sup>
13. Dwelling Room built-in cupboard and drawers, 1837, CA	chrome yellow, <sup>b</sup> lead white, <sup>b</sup> (massicot?)	oil <sup>c,f</sup>
<b>Blue paints</b>		
14. Blue counter, after 1815, CA	Prussian blue, <sup>j</sup> calcium carbonate fillers <sup>h</sup>	oil, <sup>c,h</sup> carbohydrates <sup>e</sup>
15. Meeting House woodwork, 1792, CA	Prussian blue, calcium carbonate fillers	oil <sup>c,f</sup>
16. Blue-green chest with drawer, 1821, HA	Prussian blue, <sup>j</sup> chrome yellow, <sup>h</sup> calcium carbonate fillers <sup>h</sup>	oil <sup>c,h</sup>
17. Blue oval box, n.d.	lithopone, <sup>b</sup> lead white <sup>b</sup>	oil <sup>c,f</sup>
<b>Green paints</b>		
18. Green bed, ca. 1830, ML	chrome green, calcium carbonate filler, carbon black	protein, <sup>d</sup> oil, <sup>c,h</sup> carbohydrates <sup>e</sup>
19. Green bed, n.d., ML	chrome green, calcium carbonate fillers	oil, <sup>c,h</sup> carbohydrates <sup>e</sup>
20. Green oval box, n.d., ML	green earth, lead white, iron earth pigment	oil <sup>c,h</sup>
21. Green headboard, n.d., ML	green earth, yellow ochre, charcoal black	oil <sup>c,h</sup>
<b>Orange and salmon-colored paints</b>		
22. Deaconesses cupboard, 1840, ML	red lead, <sup>i</sup> barium yellow, <sup>i</sup> iron earth pigments, <sup>i</sup> chrome yellow <sup>i</sup>	oil <sup>c</sup>
23. Amos Stewart counter, 1860, ML	chrome yellow, <sup>i</sup> red lead, <sup>i</sup> red ochre, <sup>i</sup> burnt sienna, charcoal black <sup>i</sup>	oil <sup>c</sup>
24. Tailoring closet, 1840, ML	red lead, <sup>i</sup> iron earth pigments, <sup>i</sup> chrome yellow, <sup>i</sup> charcoal black <sup>i</sup>	oil <sup>c</sup>

**Key**

ML = Mount Lebanon

WV = Watervliet, New York

EN = Enfield, New Hampshire

CA = Canterbury, New Hampshire

HA = Hancock, Massachusetts

**Notes**<sup>a</sup>Identified by polarizing light microscopy only, unless otherwise noted.<sup>b</sup>Confirmed by identifying characteristic elements by X-ray fluorescence, using a Model A Kevex X-ray fluorescence unit.<sup>c</sup>Identified by staining cross section with Rhodamine B.<sup>d</sup>Identified by staining cross section with fluorescein isothiocyanate (FITC).<sup>e</sup>Identified by staining cross section with triphenyltetrazolium chloride (TTC).<sup>f</sup>Identified by staining cross section with 2, 7 dichlorofluorescein (DCF).<sup>g</sup>Identified by presence of amide I and amide II bands in infrared spectrum.<sup>h</sup>Identified by presence of drying-oil binder by doublet between 2800 and 3000 cm<sup>-1</sup> and a peak at 1750 cm<sup>-1</sup> in the infrared spectrum; Fourier-transform infrared (FT-IR) spectroscopy using an Analect RFX-65 Model.<sup>i</sup>Confirmed by identifying characteristic elements with X-ray fluorescence in a scanning electron microscope.<sup>j</sup>Identified by presence of peaks at 2950 and 2890 cm<sup>-1</sup> in the infrared spectrum.



paint over the remnants of an original yellow paint; notably, the primary pigment was lithopone ( $\text{ZnS} + \text{BaSO}_4$ ), which was not produced until 1874. Of the seven blue objects examined to date, all but one incorporated Prussian blue as the primary colorant.

The blue paint on a handsome counter with an orange top and interior, originally built into a retiring room on the top floor of the Canterbury Shaker Village Meeting House, was found to be composed primarily of Prussian blue plus calcium carbonate-based fillers in an oil binding medium. This is the same blue paint as the second generation of blue paint found on the moldings in the third floor room of the Meeting House where the counter had been built in.

This consistent use of Prussian blue in oil disproves a popular theory among folk art collectors and dealers that many of the “dry-looking” blue paints were milk-based. It is highly unlikely that any blue paint containing Prussian blue would be a milk-based paint, as the high pH of a casein or milk-based paint would rapidly discolor the Prussian blue to an unsightly brown. This use of Prussian blue by the Shakers may also help to explain a belief that Shaker paint colors were divinely inspired. The name “celestial blue” appears in one Shaker recipe and in the records of C. Schrack and Company—a major manufacturer and distributor of paint, putty, and varnish in Philadelphia, Pennsylvania, founded in 1830—but it is a contemporary name for Prussian blue, not a descriptive term (C. Schrack and Company 1827–88).

Four green-painted beds and one green box were examined; in general, the green paints were far more opaque in appearance and thicker in application than any of the other paint cross sections examined. The green pigment on three of the beds was chrome green (a mixture of Prussian blue and lead chromate), which was readily available after the first quarter of the nineteenth century. One green bed (actually only a headboard), in the Shaker Museum collection, was painted with green earth (terre verte), yellow ochre, and charcoal black (Fig. 2). The green

*Figure 2*

Green bed from the Hancock Shaker Village collection. The cross-section analysis indicated that the green paint layer was a second generation of paint, above the remnants of the original orange paint found to be trapped in the wood fibers.



Figure 3

Shaker paint colors. These were replicated based on handwritten Shaker recipes, and the pigment combinations were identified using polarized light microscopy techniques. The linseed oil-based paints were applied to wood that had been sized with a gum on one side and remained unsized on the other.

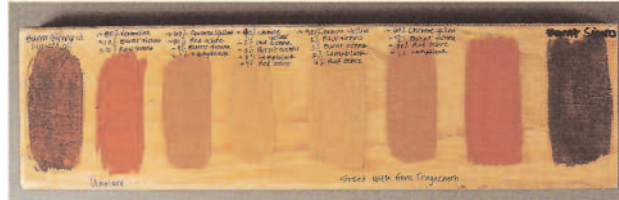

box was painted with green earth, lead white, and a small amount of chrome green. A noteworthy characteristic of the paints on the green beds from the Mount Lebanon and Winterthur collections is the presence of a green-pigmented glaze of plant resin varnish applied directly on top of the green paint layer. There is no distinct boundary between the glaze and the paint, indicating that the green glaze was applied before the green paint beneath it had completely dried. This glaze would have made the paint more saturated in color, glossier, and more durable. This method of applying paint and pigmented varnish directly relates to an 1865 correspondence from Daniel Boler at the Ministry at Watervliet, New York, to Orren Haskins, cabinetmaker at Mount Lebanon (Rieman and Burks 1993:62): “In the present case as touching the use of Varnish on the wood work of our dwellings in the sanctuary at the Mount, we have unitedly decided to have what varnish is used, put into the last coat of paint.”

This use of a pigmented, plant resin glaze over a paint layer was also found on the original red moldings from the third floor of the Canterbury Shaker Dwelling House, dated 1793, and on the red moldings in the 1792 Canterbury Meeting House.

The distinctive bright orange and salmon colors found on many Shaker objects often appear to have been created from various combinations of red lead, iron earth pigments, chrome yellow, and charcoal and/or lampblack. Bright orange occurs commonly on both the interiors and exteriors of Shaker objects, and more objects need to be studied to fully understand the variety of pigment combinations (Fig. 3).

The analysis of paints found on Shaker objects and furniture directly relates to the raw pigments in several Shaker collections. Table 2 lists the results of the analysis of bottles and other containers of raw pigments found at the Mount Lebanon and Canterbury communities. One group attributed to Canterbury Shaker Village is owned by Hancock Shaker Village and was sold in the 1932 Jordan Auction; the other group is in the collection of the Shaker Museum and comes from a variety of sources.

---

## Conclusion

The results of this initial phase of research indicate that there are several common characteristics in Shaker paints and their use on furniture and woodwork between approximately 1792 and 1860. The first is that a sizing layer was used consistently to seal the wood before the paints were applied. This sizing layer usually was a gum (perhaps gum arabic dissolved in water). A preparatory size layer meant that the first layer of paint would not penetrate deeply into the wood fibers but instead would form an even, consistently colored layer on the surface. This is an efficient way to conserve the more expensive pigmented material, and it means that one layer of paint would suffice to achieve an even color. Another recognizable characteristic is the use of thin, or dilute, paints. With the exception of the

Table 2 Raw pigments found in Shaker collections

Color	Pigment <sup>a</sup>	Village, Source
deep blue	Prussian blue, <sup>b,c</sup> calcium-based fillers <sup>b</sup>	ML, Koster Auction, 1964
pale blue	copper acetate <sup>b</sup> (verdigris)	CA, Jordan Auction, 1932
deep red	red ochre <sup>b</sup>	CA, SM
deep red	iron oxide red <sup>b</sup>	CA, Jordan Auction, 1932
deep red	red ochre <sup>b</sup>	ML, SM
medium red	red ochre <sup>b</sup>	CA, Jordan Auction, 1932
pale red	vermilion, chrome yellow, <sup>b</sup> red lead <sup>b</sup>	HA, The Ansbacher Manufacturing Co., NY
dull yellow	yellow ochre, <sup>b</sup> titanium dioxide, <sup>b</sup> calcium carbonate <sup>b</sup>	CA, Jordan Auction, 1932
bright yellow	chrome yellow, <sup>b</sup> lead white <sup>b</sup>	CA, SM
bright yellow	chrome yellow, <sup>b</sup> calcium carbonate <sup>b</sup>	CA, Jordan Auction, 1932

**Key**

ML = Mount Lebanon

CA = Canterbury, New Hampshire

SM = The Shaker Museum

HA = Hancock, Massachusetts

**Notes**<sup>a</sup>Identification by polarizing light microscopy only, unless otherwise noted.<sup>b</sup>Confirmed by identifying characteristic elements by X-ray fluorescence, using a Model A Kevex X-ray fluorescence unit.<sup>c</sup>Identified by presence of peaks at 2950 and 2890 cm<sup>-1</sup> in the infrared spectrum.

green-painted objects and the architectural paints on moldings, the paint layers were often thinly applied, and they tended to penetrate into the wood substrate despite the presence of a size layer.

The paints were most often oil-bound, and when a clear coating survived, the earliest layer was a plant resin varnish. There are shellac recipes in the Shaker recipe books, but no original shellac coatings have yet been found on painted objects and architectural elements dating from approximately the late 1700s to 1870. Although many of the painted surfaces are quite worn, cross-section evidence indicates that approximately half of these objects originally were not varnished. Two of the counters were varnished only on the tops and knobs. This varnishing of work surfaces would have helped protect them from staining and dirt and is consistent with the 1845 Millennial Law (section 9, rule 10) that states: "Varnish, if used in dwelling houses, may be applied only to the moveables therein, as the following, viz., Tables, stands, bureaus, cases of drawers, writing desks, or boxes, drawer faces, chests, chairs, etc. etc."

The pigments and binders in use were readily available and comparatively inexpensive, particularly the iron earth pigments. An 1831 U.S. Government survey on proposed tariff increases for imported paints and pigments found that the domestic sources for pigments and paints were located primarily in Vermont, New Hampshire, Massachusetts, and New York. In the same year, a Prussian blue factory in New Bedford, Massachusetts, was producing approximately 4500 kg (10,000 lb.) of Prussian blue a year and shipping it across the country (Green 1965). All of the northeastern Shaker communities would have had ready access to raw

materials for making paint and varnish, as well as for their commercial medicinal industry.

The existence of numerous Shaker paint and varnish recipes dating from the early to late 1800s, the presence of a well-used paint mill in the Canterbury Village collection, and warnings in the Millennial Laws about boiling varnish and oil in the buildings<sup>17</sup> all indicate that most of the Shaker communities were buying their raw materials in bulk and making their own paints and varnishes until at least the late 1800s, when the populations declined and commercially produced paints became readily available. Evidence from cross-section samples from objects remaining in Shaker communities supports this assumption.

Many of the objects that remained in the Shaker communities—such as buckets, beds, boxes, and countertops—were periodically repainted to freshen, brighten, or protect the surfaces. The more recent paint layers can be identified in cross section as modern, commercial paints because of the finely ground pigments, the even dispersion of the layers, and the intense staining reactions typical of modern emulsion, polyurethane, or alkyd-resin paints. In light of the fact that the Shakers eagerly embraced modern technology and timesaving devices, it is also very likely that they began using commercially made paints as soon as they became available in the late 1800s.

---

## Acknowledgments

The author is working with Amy Snodgrass at the Center for Conservation and Technical Studies, Harvard University Art Museums; and Richard C. Wolbers and Janice Carlson at the Analytical Lab of the Winterthur Museum to conduct further analysis of the inorganic and organic components of the paint and finish layers using SEM, FT-IR, and XRF. Funding for this analysis was provided by the Samuel H. Kress Foundation, and access to the Winterthur Analytical Lab equipment was part of a 1994 Winterthur Research Fellowship. The bulk of this study was conducted during a Winterthur Research Fellowship in April 1994.

---

## Notes

- 1 The Millennial Laws are a set of dictates that were designed to enforce conformity among the widespread Shaker villages. They are reprinted in their entirety in Andrews 1953. Section 9, rules 3 through 5 of the Laws read:
  3. The meeting house should be painted white without and of a bluish shade within. Houses and shops, should be as near uniform in color, as consistent; but it is advisable to have shops of a little darker shade than dwelling houses.
  4. Floors in dwelling houses, if stained at all, should be of a reddish yellow, and shop floors should be of a yellowish red.
  5. It is unadvisable for wooden buildings, fronting the street, to be painted red, brown, or black, but they should be of a lightish hue.
- 2 The Millennial Laws were first written in 1821. They were substantially expanded in 1845, and again in 1860.
- 3 A recipe in a handwritten book (*Receipt Book, Concerning Paints, Stains, Cements, Dyes, Inks, &c.*, ca. 1848–49, with the inscription: “Rosetta Hendrickson, A Present from Eld. Austin. Watervliet, NY,” p. 15) reads:

**To get Paint off from Wood**

Pour about one handful of soda to a quart of water. Let this be applied to the paint on doors, drawer faces or whatever be required or desired, as hot as possible with a cloth & the better you can apply the Soda & Water, the easier the paint will come off. Care should be taken to not let the wood get wet where there is no paint, lest it become stained. Wash or rinse off with water, and it is done. NB. The soda and water may be used until it is as soap, with paint.

- 4 A study of the architectural paint history of the Canterbury Shaker Village Dwelling House was undertaken by Susan Buck and Alex Carlisle from June to September 1994 as part of a Historic Structures Report on the building undertaken by Ann Beha Associates, Architects, in Boston.
- 5 See Stein 1992:286–304 for a discussion of the Shakers' relationship to changing technology.
- 6 Jerry Grant, former assistant director at the Shaker Museum in Old Chatham, New York, introduced the author to this book.
- 7 See the Rosetta Hendrickson recipe book (note 3 above), p. 1. A recipe for "Tere-de-Sena" stain first instructs the painter to heat raw sienna to produce burnt sienna, and then add approximately 4 oz. (113.4 g) of Chinese vermilion to 1 lb. (0.454 kg) of burnt sienna in raw linseed oil. The mode of application is as follows:

Thin with raw Oil, and apply with a bit of sheepskin, or woolen cloth, (Sheepskin the best:) after which when sufficiently dry—say, 24 hours after staining, rub it off thoroughly.

This may first be done with the common Corn Broom partly worn, applying it briskly to the stained work, after which, rub off again with a piece of Flannel or woolen cloth.

It is said that this kind of stain never fades or darkens by age, and when applied to light-colored wood, it gives a kind of Mahogany color; especially when under a coat of varnish.

- 8 All samples were examined with an Olympus BHT Series 2 fluorescence microscope with UV (300–400 nm with a 420 nm barrier filter) and V (390–420 nm with a 455 nm barrier filter) cubes. See Wolbers, Sterman, and Stavroudis (1990) and Wolbers and Landrey (1987) for additional information about cross-section microscopy techniques.
- 9 See the Rosetta Hendrickson recipe book (note 3 above), p. 33:

The Chh. Expense in Paints, Oils, Lumber &c.&c. for the New Meeting House, Watervliet 1848

<b>Paints for Meeting House</b>		<b>\$</b>
56 lbs. Whiting (for priming)	@ 2 ct	1.12
10 lbs do.	2 ct	20
278 lbs White Lead	8 ct	22.24
8 lbs Gum Shelack	15 ct	1.20
17½ lbs Verdigris	@ 40 ct	7.00
3½ lbs Saleratus	6 ct	21
58 Gall Linseed oil	81 ct	46.98
2 lbs Venitian Red	2½ ct	.05
6 lbs French Yellow	3½ ct	.21
3½ Galls. Spirits Turpentine	60 ct	2.10
11½ lbs Prussian Blue	12 ct	6.75
2 lbs Saxon Green	3 ct	.75
8 lbs Tere-de-Sena	¼	1.50
2½ lbs Chinese Vermilion	24 ct	7.50
2 Galls. Varnish	24/	6.00
6 brushes	6/	4.50
amt. card. forward		108.31

- 10 See note 3 above.

- 11 Shaker recipe from the Library of Congress collection, 1860, source unknown:

Papers of Shakers: Receipts/and/Practical/Instructions/Upon/Blue Dyeing/Wisdom gained by Adversity is Reliable/ A guide for the Inexperienced/Written August 1854 by Abigail Crosman!! Followed by cps. of letters, etc., dated 1854, 1858, 1861–1868, 1872–1875, 1888. A.Ds. and A. Cps. I Vol. 8<sup>o</sup>. Source unknown. 364.

- 12 This recipe was provided to the author by Shery Hack, curator of buildings, Canterbury Shaker Village.
- 13 This recipe is from the Library of Congress collection, and it is the Shaker Receipt book no. 363. It is available on microfiche in the Joseph Downs Collection of the Winterthur Museum and Library.
- 14 See note 3 above.
- 15 These objects, now in the collections of the Winterthur Museum, the Shaker Museum (Old Chatham, New York), Hancock Shaker Village, and Canterbury Shaker Village, as well as two privately owned Shaker collections, were examined for this study.
- 16 The presence of a gum size was characterized by a pale yellow autofluorescent material trapped in the pores of the woods, which reacted positively for the presence of carbohydrates with triphenyltetrazolium chloride (TTC). Additional analysis with FT-IR also indicated the presence of a gum in these areas.
- 17 See section 2, rule 8 in the 1845 Millennial Laws: "It is not allowable to boil oil, or varnish in our buildings anywhere."

---

## References

- Andrews, Edward Deming**  
1953 *The People Called Shakers*. New York: Oxford University Press.
- C. Schrack and Company**  
1827–88 Business Records, Joseph Downs Collection, The Winterthur Museum and Library.
- Green, Theresa Osterman**  
1965 The birth of the American paint industry. Master's thesis, University of Delaware.
- Horsham, Michael**  
1989 *The Art of the Shakers*. Secaucus, N.J.: Chartwell Books.
- Mackenzie, Colin**  
1829 *Mackenzie's Five Thousand Receipts in all the Useful and Domestic Arts*. Philadelphia: James Kay, Jun. and Brother.
- Rieman, Timothy, and Jean Burks**  
1993 *The Complete Book of Shaker Furniture*. New York: Harry N. Abrams.
- Stein, Stephen**  
1992 *The Shaker Experience in America*. New Haven, Conn.: Yale University Press.
- Tingry, P. F.**  
1804 *The Painter and Varnisher's Guide*. London: Printed for G. Kearsley by J. Taylor.
- Wolbers, R., and G. Landrey**  
1987 The use of direct reactive fluorescent dyes for the characterization of binding media in cross-sectional examinations. In *AIC Preprints, 15th Annual Meeting, American Institute for Conservation, Vancouver, British Columbia*, 168–203. Washington, D.C.: American Institute for Conservation of Historic and Artistic Works.
- Wolbers, R., N. Sterman, and C. Stavroudis**  
1990 *Notes for Workshop in New Methods in the Cleaning of Paintings. Report*. Marina del Rey, Calif.: Getty Conservation Institute.

PART THREE

## Historical Materials and Techniques



# Form and Polychromy: Two Different Concepts in One Object

## Notes on Seventeenth-Century Sculpture Workshop Practices in Bavaria

Hans Portsteffen

**I**N RECENT YEARS, a number of polychrome sculptures were examined and treated by the author. They belong to the first generation of sculptures in Bavaria to reflect the influence of Italian Mannerism in the province. The relationship to Italian Renaissance sculpture is evident, as is the sculptors' awareness of Italian art via contact with artists in Munich and Augsburg who had visited and trained in Italy. Roots of the development of Baroque ideas can be traced. A general examination revealed obvious differences in the outline of decorative elements between the carved surfaces and the polychromy. Furthermore, eyes, eyebrows, lips, and cheeks were found to have been painted directly on the carved wooden surface, and must have been covered with layers of priming and the authentic polychromy immediately after carving.

Such observations have been made repeatedly, but there is still no accepted explanation for this quite commonly used local coloring in combination with polychromy (Rosenfeld 1990:153).<sup>1</sup> Three sculptural groups have been selected to explain and illustrate these observations in detail.

---

### Case Studies

The sculptural group *The Descent from the Cross* (Fig. 1) is attributed to Christoph Rodt, a sculptor who lived from the end of the sixteenth century until 1643 in Swabia, an area southeast of Ulm (Miller 1989; Mannes 1992). The group is thought to be the centerpiece of a lost altarpiece from the Roggenburg monastery and is now located in the parochial church of Neuburg an der Kammel, Rodt's former village home. The work is dated around 1625. Exact proof of dating and provenance is missing.

Little is known about Rodt. In addition to a number of attributed pieces, there is a monumental altarpiece in Illertissen (a small town near Ulm), which he personally signed in 1604. Moreover, a document written in his own hand has survived. It was found in the head of one of the retable figures. In this document, he introduces his assistants and the painter of the Illertissen retable and gives us his comments on bad beer, expensive corn, and so on (Mannes 1992:106; Becker and Portsteffen 1991).

The Neuburg sculptures were discovered in 1910, stored in boxes in the attic of the castle in Neuburg. Hitherto totally forgotten, this spectacular find led to the first restoration and reconstruction of the group in the arrangement as seen in Figure 1. About 70% of the original polychromy and gilding has survived. The reason for the actual treatment and examination was the poor condition of the polychromy; gilding and



Figure 1

*The Descent from the Cross*, attributed to Christoph Rodt. First quarter of the seventeenth century. Limewood. H: approx. 250 cm. In the parochial church of Neuburg an der Kammel.

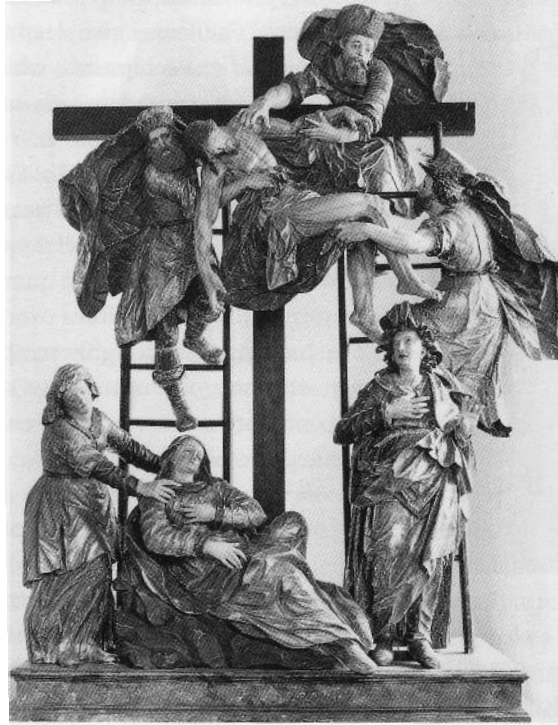

paint layers were flaking due to inadequate environmental conditions. The group was acquired by the Bavarian state from a private owner. Consequently, the group was transferred to the village church of Neuburg.

The original polychromy shows silvered and gilded areas of the drapery, and faces and arms are painted in a very lively manner. Close examination revealed that the painter did not fully comprehend the sculptor's concept. This is supported by four observations:

1. A hole had been prepared for a separately carved button. The planned button had been forgotten, and the painter covered the site in a manner similar to the surrounding area.
2. The painter did not pay careful attention to the borders of inner and outer parts of the robes. After applying silver leaf to large areas of the outer part of the robe, he needed to correct those areas and did so by applying gold leaf over the silver leaf.
3. One leg was painted flesh color; apparently, the painter did not recognize the carved breeches. He later corrected this by adding silver leaf.
4. The carved relief area in the cap of one of the upper sculptures was overlooked; the outline of the carving was not reoutlined in the priming layers.



Figure 2

Bust of *Saint Kunigunde*, attributed to Christoph Rodt. First quarter of the seventeenth century. Large areas of the authentic polychromy are lost. Limewood. H: 45.5 cm. In the Collection of Heimatmuseum, Illertissen.

The most important observation made was in the lacunae of the polychromy on the face of Saint John. Beneath the priming and polychromy and directly on the wooden surface, the lips are painted red.

The busts of Saint Kunigunde (Fig. 2) and Saint Heinrich are attributed to the same sculptor. They have survived, although badly damaged, and are now in the Heimatmuseum in Illertissen. These polychrome busts had once been attached to reliquaries, which are now missing. The remaining parts of the polychromy are original and have never been



Figure 3  
Detail of bust of *Saint Kunigunde* (as in Fig. 2).  
The system of colored eyes, cheeks, and lips is  
clearly seen in the lacunae of the polychromy.



Figure 4  
The Godfather from *The Coronation of the Virgin Mary*, artist unknown. First quarter of the seventeenth century. Limewood. H:109 cm. In the monastery of Oberschönenfeld.

treated. In spite of the losses, the colorful and very delicate decoration is still apparent. The losses give deep insight into the technique and the elaborate carving of the sculptures, which is covered with thick priming layers. Again the lips are painted directly on the wood surface, as are the cheeks, eyes, and eyebrows (Fig. 3).

The third example is *The Coronation of the Virgin Mary* in the monastery of Oberschönenfeld near Augsburg (Fig. 4). Again, the sculptures are fragments of a lost altarpiece. These sculptures, carved by an unknown artist during the first quarter of the seventeenth century, have been overpainted several times over the years. In the 1960s, some parts of the overpainting were roughly scraped away. Despite this treatment, large areas of original polychromy have survived and were recently restored. Close examination revealed differences between the elaborately carved surface and the polychromy:

- The detailed seam decoration is totally covered by thick priming layers (Figs. 5, 6);
- the geometrically structured surface of the scarf is changed into a flat, floral-painted area (Fig. 7); and
- the decoration of the inner and outer parts of the robe does not adhere exactly to the flow of the carved pleats.

These examples show that the sculptors and painters did not follow the same concepts. The differences seem to prove either the painter's independence in bestowing upon the object his impression of what it should look like or the painter's lack of knowledge of what the sculptor had in mind and a different understanding of quality.

It is obvious that different individuals were involved, that the work was divided into several steps, and that communication between the sculptor and the painter was poor.

All the aforementioned sculptures have lips painted directly on the wood surface, in addition to the overlaying full polychromy. On one piece, colored eyes, eyebrows, and cheeks could be seen on the carved wooden surface due to losses of paint layers. Of course, original paint layers were not removed to determine painted eyes on all the objects, but the discovery of red lips on all of them certainly proves a system of preliminary coloring for details on the carved surface, which must have been covered with priming layers and then polychromy immediately after carving. Who was responsible for these preliminary colorings, and for what purpose?

The discovery of such painted details—along with a finishing layer of tinted brown glaze—on the wood surfaces of sculptures by Riemenschneider and other early Renaissance sculptors led to the theory of the so-called nonpolychromed sculpture or “wooden sculpture with painted details” (Taubert 1983a:73; Rosenfeld 1990; Oellermann 1992).<sup>2</sup> Each new discovery of these colorings is usually considered to support this theory (Westhoff 1993; Meurer 1993). In such cases, the sculptures were planned without polychromy. If polychromy was sometimes added at a later date, this was due to a change in fashion or to a disregard of the artist's concept.

The sculptures studied here have colored details on the wood surfaces along with a polychromy that, without question, was executed immediately following the carving process and the coloring of the details.<sup>3</sup> To find an explanation for this puzzling phenomenon (colored details cov-

ered by polychromy), it is necessary to study the workshop practices at that time, as well as the contract terms according to which the objects were created. Were the carving and the polychromy carried out in the same workshop? Did the sculptor and the painter have separate contracts? Was there any contact or communication between the sculptor and the painter? How did the artists feel about division of work? How much time passed between the making of the sculpture and the application of the polychromy?

## Influence of the Guilds



*Figure 5*  
Detail of the seam decoration, as seen in the Godfather (see Fig. 4). The elaborately carved wooden decoration is covered by thick priming layers.

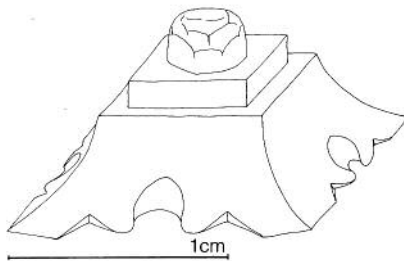

*Figure 6*  
Drawing of reconstruction of the carved seam decoration in the Godfather (see Figs. 4 and 5).

*Figure 7*  
Drawing of reconstruction of the carved structure of the Godfather's scarf, which is changed to a flat, floral-painted design in the polychromy (compare to Fig. 4).

From the Middle Ages to the eighteenth and nineteenth centuries in the German-speaking countries, craftsmen were organized in guilds. Guild rules strictly delineated the different spheres of competence and regulated commercial practice. In general, wood sculptors were not allowed to use colors, and painters were not allowed to carve wood. Several surviving contracts confirm this specialization (Huth 1967:70). This general formula, however, is much too simple to describe the situation. The close relationship between the work of painting and sculpture in altarpieces that combined painting and polychrome sculpture makes the matter even more complicated, and it was a constant cause of quarrels and discussion among the guilds. In 1463 in Basel and in 1475 in Munich, painters were allowed to hire their own sculptors. They could deliver complete polychrome sculptures. This led to angry protests by the sculptors (Baxandall 1980:112).

The fifteenth century saw the development of the practice of commissioning large projects such as altarpieces to only one person, who would act as the general contractor (*Verleger* in German) with various subcontractors. For example, a painter might carry out part of the work in his own workshop and subcontract additional work to other artists and/or artisans. This concept was well known for the *Herlin* and *Syrlin* (carpenters), *Strigel* and *Wohlgemut* (painters), and *Weckmann* and *Lederer* (sculptors), who worked as central contractors to deliver complete altarpieces (Baxandall 1980:118). In such situations, the creative idea of the object was attributed to the artist who controlled, signed, and delivered the work. Generally the whole commission was planned and discussed using a drawing (*Visierung*) that had been approved by the client.

To further complicate this complex system, the different crafts were governed by different rules, just as the same guild in different towns also varied in their rules. In Munich (Huth 1967:73) and Ulm (Weilandt 1993:370), painters and sculptors belonged to the same guild but had to follow different rules. In these two cities and in several others, membership in two different guilds was possible. In addition to the guilds, which

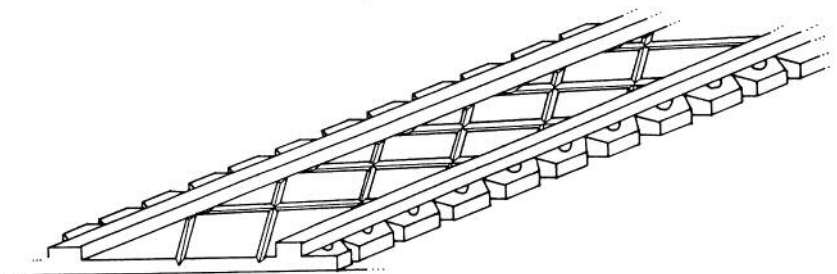

existed only in major cities with a sufficient number of craftsmen, there were four special groups not subject to these guild regulations:

1. Craftsmen in self-governed imperial cities (*Freie Reichstädte*). In the imperial cities, the town council fixed the rules and controlled the conditions governing arts and crafts. In Nuremberg, for example, painting and sculpture were decreed to be free arts and were not regulated by guild rules (Huth 1967:79; Baxandall 1980:106). This was a boon for artists such as Veit Stoss, who worked as painter and sculptor.
2. Artists and craftsmen under the jurisdiction or in the employment of the court and the confraternities (*Hof- und Klosterbefreite*).
3. Non-guild members, the so-called *Pfuscher*, who were more or less tolerated. They could not afford a master's license nor were able to marry a master's widow and therefore had no way to acquire citizenship and membership in a guild (Schindler 1985:265).
4. Finally, those in the guild-free countryside, who could work under various contract conditions (von Tyszka 1908:72; Koller 1982b). Their contracts did not fall under guild rules and were made to fit the needs of the client and the artists. Here, clever negotiations determined the conditions.

It is obvious that such work was created in a certain contract and workshop context that needs to be investigated for each individual piece. Regional differences must be considered as well. Existing contracts provide valuable information, but they cannot, of course, reflect the conditions of day-to-day practice (routine work, votive paintings, sales, etc.). The relatively large number of contracts and rules dating from the fourteenth and fifteenth centuries offer a good picture of the historical background.

In conclusion, one finds, on the one hand, general contracts with one artist who had subcontractors and, on the other hand, separate contracts with individual artists and artisans (Baxandall 1980:104–5). In any case, this means that division of work was customary. Only rarely does one find sculptures that were polychromed by the sculptor himself or by his own workshop.

---

## Seventeenth- and Eighteenth-Century Practices

Separate contracts for separate steps of work appear to be the general practice in the seventeenth and eighteenth centuries. Several authors have studied the conditions reigning at this time. Obviously, regional differences did exist. Again, it would be necessary to investigate every object, which, of course, is not always possible.

In the eighteenth century, the crafts of painters and sculptors were strictly separated, specialized, and self-organized (Koller 1974a:31; Schiessl 1979:10). If the sculptor had a contract for a polychrome piece, he usually had to pass on the finished, carved piece to a painter (Schiessl 1979:10, n. 40). Guild organization still existed and was even more restrictive. It was possible for a painter or a sculptor to provide the idea, sketch, and/or the plan for the work, as well as the polychromy. Several colored designs on paper and small model examples for retables and sculp-

tures have survived. Such pieces were made as a means of furthering discussion among the contract partners and artisans and of helping the future owner to picture the final work (Schiessl 1979:17; Koller 1974a:24). Contracts were then made with each artisan separately (Koller 1974a:33; Volk 1984:189).<sup>4</sup> The growing self-confidence among the different artists led to the practice of signing their work separately (Taubert 1983b). Painters responsible for the polychromy on sculptures and retables were no longer anonymous.

---

## The Procedure

Usually the painter started working immediately after completion of the carving or erection of an altarpiece. But time did not pass as fast as it does today. If the polychrome concept was discussed or contracted during or after erection or carving was completed, it is possible that some time elapsed before the polychromy was applied. There are known instances where years passed after the erection of an altar retable or the carving of a sculpture before the polychromy was applied. This might have been due to lack of funds, a change of mind, or uncertain times. One known case is the Baroque organ in Maihingen (1737), which was never polychromed at all (Walch 1991; Böttger 1991; Scheuch 1991). The rough wood construction and surface of the carvings can still be seen, and blemishes and joints are filled with paste (Fig. 8). This is actually a very rare and astonishing example of an unpainted work in a church with an elaborately polychromed interior. Here, too, we find lips and eyes painted directly on the rough and uneven wood surface, which calls for a finish of priming and polychromy. Another example is the monumental retable in the Church of Überlingen, where the design and the sculpture were contracted to Jörg Zürn in 1613 and the carpentry to Joseph Mutschlenbeck, while the polychromy was commissioned in January 1614 to the painter Wilhelm Baumhauer. During the following half-year, the polychromy order was canceled “for various reasons,” as the document says, and it was never executed (von Manteuffel 1969:17, 154, 156).

*Figure 8*  
Organ in Maihingen/Donau-Ries, Johann Martin Baumeister 1737. Detail of the sculpture decoration of the organ. The face of the angel shows repairs in the wood, which calls for priming and polychromy. Eyes and lips are painted. Limewood. In the parochial church of Maihingen.



Other examples of delay in executing the polychromy are the pulpit and high altar of the monastery church of Saint Veit an der Glan, Austria, constructed in 1634 and painted in 1637; the altarpiece in the parochial church in Strasbourg, Austria, constructed in 1747 and painted in 1772 (Koller 1974a:31); and the high altar in the monastery of Disentis, where the polychromy was applied twenty years later (Brachert 1972:161). For the medieval Pietá of Georgenberg, Austria, there is literary proof that it stood in the church after carving for some time before it was polychromed (Koller 1982a; Koller 1993). Other examples have been published (Schiessl 1979:29; Bayerisches Nationalmuseum 1985:264; Württembergisches Landesmuseum Stuttgart 1993:26:447, 27:448).

---

## Conclusion

Conditions such as poor communication, division of labor, and delay in contracting different steps of the work influenced artistic production. A work of art cannot be executed in separate steps by various artists without consequences, especially when there is little or no contact between the persons involved, or when there is a lapse of time between the operations.

Little is known about the relationship between sculptors and painters and how they coped with these circumstances. Literary sources may shed some light. For example, there is a statement by the sculptor Hagenauer, who made the high altar of Köstendorf, Austria, in which he calls for precise priming. "Not to waste the quality of carving," he wanted to be contracted for the priming and the polychromy as well. Apparently he had had some bad experiences with painters (Koller 1974b:118):

To preserve my pleasure in the clear carving and diversity of facial expression and not, as has often enough happened to me, to find it wasted by poor priming; to the extent that neither the clear contours, the diversity of expressions, nor the difference between the flowers and the other ornaments could be discerned, nor who it was made by and what it was meant to be, therefore I plan to take over not only the carving but the polychromy as well.<sup>5</sup>

This statement may reflect the situation and the feelings of the sculptors who had to pass their work on to a painter, or who were contracted separately. If one presupposes any professional pride, such discontent must have been widespread.<sup>6</sup> From this point of view, the coloring of the eyes, cheeks, lips, and so on, directly on the wood surface might be interpreted as the sculptor's finishing touch: an indication that he wanted to assert his concept of his creation before passing it on to a painter. This interpretation stresses the artist's feelings, which is, of course, a modern interpretation. In any case, the sculptor's own coloring of details confirms that there were strict guild rules and a division of labor.

The concerned artists and artisans probably knew that the polychromy might be executed several years later, or perhaps not at all. In such cases of delayed polychromy, the provisional coloring of the eyes, et cetera, served as a first step toward the polychrome finish of the piece and allowed for immediate use. To describe this phenomenon, the term *temporary* or *provisional coloring* might be useful.

---

**Notes**

- 1 Some of these observations follow:
- (bei) den im Verlauf der Schwanthaler-Restaurierungen untersuchten 67 Figurenkarnaten. . . . finden sich fast stets direkt auf dem Holz schwarze Augen- und rote Lippen- sowie Blut-(z.B. bei Sebastiansfiguren) angaben, die von der Hand des Bildhauers stammen dürften [Examination of 67 polychrome sculptures attributed to members of the Schwanthaler family revealed that most of the sculptures showed black-colored eyes, red lips and blood marks (in the case of sculptures of Saint Sebastian) painted directly onto the wooden surface, probably done by the sculptor] (Koller 1974a:48).
- dunkel eingesetzte Pupillen, die sogar unter Kreidegrundfassungen gefunden worden sind . . . eine Gepflogenheit des bildhauerischen Gestaltungsvorgangs, durch die der Blick festgelegt wurde [colored eyes, found underneath polychromy are part of the customary manner of design, determining the direction of the glance] (Brachert and Kobler 1981:807).
- Denn selbst wenn man eine direkt aufs Holz gemalte Pupille findet, muss es sich nicht immer um ein holzfarbendes Bildwerk handeln, sondern man muss damit rechnen, dass der Bildhauer während seiner Arbeit eine solche Zeichnung als Hilfsmittel benutzt hat, um seinem Werk Lebendigkeit zu verleihen und evt. schnitztechnische Korrekturen vornehmen zu können [The finding of colored eyes on the wooden surface does not always prove that the sculpture is a nonpolychromed one. It is just as possible that the sculptor uses these colored markings to enliven the piece and to control his work] (Westhoff and Haussman 1987:130).
- 2 See Rosenfeld 1990 for references on this subject.
- 3 The authenticity of the polychromy is usually determined by the manner of the polychromy, by the presence of visible repair work in the wooden surface that called for a covering by polychromy, by the lack of any patina (soiling) on the wooden surface, and by the evidence of the typical rough surface generally prepared for the better adhesion of the priming layers.
- 4 The high altar in the monastery church of Fürstenzell near Passau fits as an example for division of work and separate contracts: design of the retable, J. B. Straub; sculpture work, J. B. Straub; carpentry, Jacob Kalchgrueb; carved ornaments, Wolfgang Reittmayr; polychromy and gilding, Andreas Math.
- 5 Translated by M. Nierhaus from the German:
- Und damit meine Freyd bey reiner Ausarbeitung und verschidtenen Ausdruck der Gesichter mir vollkommen bleibe und nicht so, wie es mir schon oftmals geschehen ist, durch Vergründung verpatzet wird, dass man weder mehr eine reinen Conturn noch verschiedene Gesichtsbildung, weder Unterschied der Blumen noch anderer Auszierung erkennt hat, von wem es gemacht und was es sein oder vorstellen sollte, so gedänke zugleich auch nebst der Bildhauer- auch die Fassarbeit zu Übernehmen.
- 6 According to some other contracts of that time, the sculptor was required to finish his part with the priming. This is reasonable, because the accuracy of his carving would not then be affected by the influence of the painter (Koller 1976:163).

---

**References**

- Baxandall, M.  
1980 *The Limewood Sculpture of Renaissance Germany*. New Haven, Conn., and London: Yale University Press.
- Bayerisches Nationalmuseum  
1985 *Bayerische Rokokoplastik—Vom Entwurf zur Ausführung*. Munich: Bayerisches Nationalmuseum.
- Becker, R., and H. Portsteffen  
1991 Die Kreuzabnahme von Christoph Rodt in Neuburg an der Kammel. *Zeitschrift für Kunsttechnologie und Konservierung* 2:246–62.

- Böttger, P.**  
1991 Die Kirche des ehem. Franziskaner-Minoritenklosters in Maihingen. Zur Gesamtrestaurierung und zur Restaurierung der Orgel 1979–1990. *Arbeitsheft des Bayerischen Landesamtes für Denkmalpflege* 52:24–34.
- Brachert, T.**  
1972 Die Techniken der polychromen Holzskulptur. *Maltechnik Restauo* 3:153–78.
- Brachert, T., and F. Kobler**  
1981 Fassung von Bildwerken. In *Reallexikon zur Deutschen Kunstgeschichte*, vol. 7, ed. Willibald Sauerländer and Karl August Wirth, 743–826. Munich: Alfred Druckenmüller.
- Huth, H.**  
1967 *Künstler und Werkstatt der Spätgotik*. Darmstadt, Germany: Wissenschaftliche Buchgesellschaft.
- Koller, M.**  
1974a Barockaltäre in Österreich: Technik-Fassung-Konservierung. In *Restauratorenblätter der Denkmalpflege in Österreich*, vol. 2, 17–64. Vienna: Bundesdenkmalamt Wien.  
1974b Polierweiss—Eine Sondertechnik des Barock. In *Restauratorenblätter der Denkmalpflege in Österreich*, vol. 2, 117–24. Vienna: Bundesdenkmalamt Wien.  
1976 Fassung und Fassmalerei an Barockaltären. *Maltechnik-Restauo* 3:157–72.  
1982a Das Frühwerk Riemenschneiders—Zur Bilanz des Berliner Forschungsprojektes. *Maltechnik Restauo* 4:282–86  
1982b Zur Sozialgeschichte von Kunst und Handwerk im 17. Jahrhundert, Datenlage und Forschungsstand. In *Wolfenbütteler Arbeiten zur Barockforschung*, vol. 13, ed. W. Brückner, K. Blickle, and C. Breuer, 425–40. Wiesbaden: Harrasowitz.  
1993 Das Vesperbild aus St. Georgenberg/Tirol. *Restauo* 5:295.
- Mannes, J.**  
1992 Der Hochaltar Christoph Rodts in der Pfarrkirche St. Martin zu Illertissen. Master's thesis, University of Würzburg.
- Meurer, H.**  
1993 Zum Verständnis der holzsichtigen Skulptur. In *Meisterwerke Massenhaft—Die Bildhauerwerkstatt des Niklaus Weckmann und die Malerei in Ulm um 1500*, 147–52. Exhibition catalogue. Stuttgart: Württembergisches Landesmuseum Stuttgart.
- Miller, A.**  
1989 Christoph Rodt, ein schwäbischer Bildhauer des Frühbarocks. *Heimatkundliche Schriftenreihe für den Landkreis Günzburg* 9:3-7. Günzburg, Germany: Historischer Verein Günzburg.
- Oellermann, E.**  
1992 Der Hochaltar in St. Martin zu Lorch am Rhein. In *Flügelaltäre des späten Mittelalter*, ed. Krohm and Oellermann, 9–22. Berlin: Staatliche Museum, Preussischer Kulturbesitz, Riemann.
- Rosenfeld, J.**  
1990 *Die nichtpolychromierte Retabelskulptur als bildreformerisches Phänomen im ausgehenden Mittelalter und in der beginnenden Neuzeit*. Ammersbek bei Hamburg, Germany: Verlag an der Lottbek.
- Scheuch, A.**  
1991 Zu den Restaurierungsarbeiten am Orgelgehäuse der Barockorgel der Maihinger Klosterkirche. *Arbeitsheft des Bayerischen Landesamtes für Denkmalpflege* 52:99–105.



- Schiessl, U.  
1979 *Rokokofassung-Materialillusion*. Mittenwald, Germany: Mäander.
- Schindler, H.  
1985 *Bayerische Bildhauer*. Munich: Friedrich Pustet.
- Taubert, J.  
1983a Zur Oberflächengestalt der sogenannten ungefassten spätgotischen Holzplastik. In *Farbige Skulpturen, Bedeutung-Fassung-Restaurierung*, 73–88. Munich: Callwey.  
1983b Zur Restaurierung des Kreuzifixes von Ignaz Günther aus Altmanstein. In *Farbige Skulpturen, Bedeutung-Fassung-Restaurierung*, 195–98. Munich: Callwey.
- Volk, P.  
1984 *Johann Baptist Straub 1704–1784*. Munich: Hirmer.
- von Manteuffel, C. Z.  
1969 *Die Bildhauerfamilie Zürn 1606–1666*. Weissenhorn: Konrad.
- von Tyszka, C.  
1908 *Handwerk und Handwerker in Bayern im 18. Jahrhundert*. Inaugural diss., Hone Staatswissenschaftliche Fakultät der Königlichen Eberhard-Karls-Universität Tübingen.
- Walch, K.  
1991 Zur Restaurierung und Dokumentation der Maihinger Orgel. *Arbeitsheft des Bayerischen Landesamtes für Denkmalpflege* 52:40–47.
- Weilandt, G.  
1993 Die Ulmer Künstler und ihre Zunft. In *Meisterwerke Massenhaft—Die Bildhauerwerkstatt des Niklaus Weckmann und die Malerei in Ulm um 1500*, 369–88. Exhibition catalogue. Stuttgart: Württembergisches Landesmuseum Stuttgart.
- Westhoff, H.  
1993 Holzlichtige Skulptur aus der Werkstatt des Nikolaus Weckmann. In *Meisterwerke Massenhaft—Die Bildhauerwerkstatt des Niklaus Weckmann und die Malerei in Ulm um 1500*, 135–46. Exhibition catalogue. Stuttgart: Württembergisches Landesmuseum Stuttgart.
- Westhoff, H., and B. Haussmann  
1987 Zwiefalten und Alpirsbach—zwei monochrome Altäre? *Zeitschrift für Kunsttechnologie und Konservierung* 1:125–30.
- Württembergisches Landesmuseum Stuttgart  
1993 *Meisterwerke Massenhaft—Die Bildhauerwerkstatt des Niklaus Weckmann und die Malerei in Ulm um 1500*. Exhibition catalogue. Stuttgart: Württembergisches Landesmuseum Stuttgart.

# Reconstruction and Analysis of Bismuth Painting

Renate Gold

**I**N SOUTHERN GERMANY AND SWITZERLAND, an unusual form of painting was developed in the sixteenth century: the technique of bismuth painting. The technique is found mostly on small decorative caskets and beech (*Fagus*) boxes, and occasionally on wooden plates and altars. The lids of the boxes show figurative scenes from the Old and New Testaments with couples dressed in traditional sixteenth-century clothing (Fig. 1). The remaining surface areas are filled with schematic leaf ornamentation or dense designs of flowers, fruits, and symbols of betrothal and marriage (Fig. 2). A number of the boxes that have been examined have inscriptions, and approximately forty are dated. The first boxes appear to have been produced around 1490; however, it was not until 1613 that the governing council of the city of Nuremberg formed an official guild of bismuth painters.

Bismuth has been known as a metal since Agricola (1490–1555) and Paracelsus (1493–1541) and belongs to rare elements found in the cobalt and nickel mines of Saxony, England, and Bolivia, among others. It is a brittle metal, ranging from silver-white to a reddish hue in color. The metal can be pulverized, and its surface remains unchanged in a dry atmosphere but oxidizes under humid conditions. It is found in its oxidized form on the decorated boxes, mostly dark gray and matte in appearance. Very little remains of the warm silvery and blue-red iridescent hue that this metal originally reflected and that made it so fascinating to the viewer.

The technique of bismuth painting may be divided into three categories:

1. A continuous bismuth ground onto which the painted decoration was applied
2. An application of bismuth paint within the painted decoration—as, for example, along borders and collars of clothing (Fig. 3)
3. An application of bismuth for small flowers and stems as part of the background

In short, the term *bismuth paint* may refer to decorative applications, though the technique of a solid bismuth ground is predominant.

*Figure 1*

Box, ca. 1560. Painted with bismuth.  
H:14.5 cm; W:36.5 cm; D:24 cm. From the  
Germanisches Nationalmuseum, Nuremberg  
(Inventory no. HG 7865).



## Summary of Published Technical Research into Bismuth

*Figure 2*

Writing cabinet, ca. 1650, with bismuth  
ground. H:31.5 cm; W:41 cm; D:30.5 cm.  
From the Bayerisches Nationalmuseum,  
Munich (Inventory no. 60/I 14).

*Figure 3*

Box, dated 1544. Gold background, with  
bismuth on the border of the garments.  
H:17.4 cm; W:45.8 cm; D:29.5 cm. From  
the Bayerisches Nationalmuseum, Munich  
(Inventory no. 10/303).

The study of bismuth painting was carried out by the author for her doctoral dissertation, titled “Bismuth Painting.” As part of the study, historical and contemporary records were researched to compile a sequential record of investigations into the materials and techniques used for bismuth decoration.

### First attempt at reconstruction of bismuth by Wibel, 1890

In 1890, Justus Brinckmann, the founding director of the Museum für Kunst und Gewerbe (Museum of Arts and Crafts) in Hamburg, bought a bismuth box dated 1555<sup>1</sup> and asked Ferdinand Wibel, director of the chemical state laboratory, to carry out an examination. In an extensive 1891 essay on the results of his research, Wibel describes a bismuth surface that is visible in the center of the painted box and, after removal of the surface varnish, appears as a matte lead gray area with a red tone. By removing a small sample from the 0.1 mm metal layer with a knife, he confirmed that it is a brittle metal that flakes off in small pieces, revealing an underlying ground of chalk with a glue-like binder (Wibel 1891).

Wibel determined that the paint ground consisted almost exclusively of bismuth with small traces of antimony and arsenic; copper and tin were completely absent (Wibel 1891:5). Deciding that pure bismuth could not possibly be hammered or rolled into a foil, unless the old metal



technicians knew a procedure that had since become lost, he concluded that the metal ground resulted not from a foil applied to the ground but from pulverized bismuth applied onto the chalk ground and burnished evenly with a polishing tool or burnishing stone until it achieved an even reflecting surface that resembled metal. He attempted to reproduce the bismuth surface of the sixteenth- and seventeenth-century boxes. For this purpose, he applied a thin slurry of chalk with glue onto the wood surface. After it hardened, he again applied a thin size and sprinkled finely ground bismuth powder onto it. After it was dry, he polished the now-matte gray area lightly with a thin polishing steel and achieved a beautifully reflective metal-like surface (Wibel 1891:7).

### Chemical attempts by Buchner, 1908

In his *Hilfsbuch für Metalltechniker* (1923:259–60), Georg Buchner, a Munich chemist, investigated the technique of bismuth painting. Aware of Wibel's attempts to recreate bismuth paint, he sought an easier way to apply bismuth evenly onto a canvas, and first reported his successful efforts in an article, "Ueber Wismutmalerei" (Buchner 1908:121–22).

He produced the surface in the following manner: To 100 g of bismuth subnitrate,<sup>2</sup> he added 200 g of water and continued to add pure hydrochloric acid to the mixture until he achieved a clear solution, then thinned the solution with approximately 1 l of water. He placed a strip of zinc into this bismuth solution and left it for several days. The zinc caused the solution to turn gray and the bismuth to precipitate out in a fine foam, while the zinc went into solution in place of the bismuth. He then removed the remaining zinc strip, decanted the now-clear solution, rinsed it thoroughly, and let the bismuth settle. After forcing the fine metallic bismuth slurry through a glass filter, he immediately applied the bismuth slurry to a wooden surface that had been primed with a chalk ground. His instructions then continued as follows (Buchner 1910:135):

After drying, a matte, mouse-gray bismuth layer is obtained; this should now be burnished to high gloss with an agate; again, this is an easy procedure to carry out and produces an almost silver-white bismuth surface that can then be painted in the historical manner.

Only in the third, enlarged edition (1923:259–60) of his *Hilfsbuch für Metalltechniker* does Buchner list his recipe almost word for word.

### Lippmann and the history of bismuth

In his 1930 article "Die Geschichte des Wismuts zwischen 1400 und 1800," Edmund Oskar von Lippmann discusses a small bismuth-decorated box from the Germanic Museum, dated approximately 1480, to demonstrate the discovery of bismuth, noting "the importance of this metal discovered during the innovation of the book printing process" (1930:362–63). In a 1933 article, Lippmann offers the "postscript to the history of bismuth" by quoting the Nuremberg Bismuth Guild (Lippmann 1933:4). What is interesting about Lippmann's articles is the fact that, although as a chemist he discusses various aspects of bismuth, he does not talk about the difficulty of producing a bismuth ground. Instead, he merely mentions that the ordinarily brittle bismuth, if scattered as a fine powder onto a black chalk

ground, may be burnished into a brilliantly metallic, reflective surface. He published his essays in a multiple volume book in 1953 (Lippmann 1953:86–91).

### Reconstructions by Deggeller, Sutter, and Bohring, 1963

These three authors wrote articles on bismuth and their experiences in reproducing a bismuth ground. Deggeller (1963) abbreviated Buchner's 1910 recipe, and Sutter (1963) cited it almost verbatim and added his own results from attempts to reconstruct the chalk ground. Bohring (1963) modified Buchner's techniques by wetting the zinc strip with hydrochloric acid before placing it into the solution of bismuth, which was produced from bismuth subnitrate, water, and hydrochloric acid. He then ground the bismuth slurry on a glass plate, added rabbit-skin glue, and applied the mixture to a chalk ground consisting of a minimum of four layers. Bohring reconstructed the method "in the modern sense" and expressed regrets that the technique of bismuth painting had fallen into oblivion.

### Reconstructions by Wehlte, 1967

In 1967, Kurt Wehlte published his groundbreaking *Werkstoffe und Techniken der Malerei*, in which he cited, almost verbatim, Bohring's 1963 reconstruction experiments. He considers this the most successful of the many attempts to reproduce bismuth painting, but adds that "it is possible to reach the goal by using finely ground bismuth metal in its dry form, then adding water and glue and burnishing upon drying. The larger granules of the bismuth powder, in contrast to the bismuth slurry, result in a totally different visual effect" (Wehlte 1967:745–46).

Wehlte points out in his introduction that in his three decades of artistic and technical work, he had often heard of bismuth paint but had never been able to obtain details from art historians nor had he found much useful information in the technical literature (Wehlte 1967:744). Wehlte placed bismuth painting in a chapter on special techniques and, by highlighting it as he did for techniques of wall painting or panel painting, rejuvenated the technique. The popularity of Wehlte's book, which has appeared in numerous editions, has increased knowledge and awareness among experts of this almost forgotten technique.

### Differentiation between dry and wet methods by Herrmann

Christian Herrmann (1977) completed a study in which he followed Buchner's recipe in detail and added Sutter's observations, as well as his own amendments. Notably, Herrmann describes the process of obtaining the bismuth slurry as a *wet process*, and characterizes the reconstruction attempts based on mechanical pulverization of the metallic bismuth as a *dry process*. One of the dry methods is the reconstruction process listed by Bohring, first presented by Wehlte, in which pure bismuth powder is ground with a mortar and pestle to a very fine powder and then shaken through a fine copper sieve. Another reconstruction of a dry process was Sutter's recipe, in which the slurry was applied to a chalk ground consisting of four layers that had been finely polished with sandpaper and, after six hours, was burnished with an agate. Bohring had described this process as a dry method.

### Practical translation of recipes by Mayr

Katharina Mayr (1977:72–73, 82–84)<sup>3</sup> reported her study in which she reconstructed bismuth ground based on the articles by Wibel, Deggeller, and Sutter, as well as on both Buchner (although he was not mentioned by name) and Bohring. She presented eight reconstruction experiments starting with Wibel's recipe, which she modified in a second experiment by increasing the concentration of the glue layer and thereby binding more of the bismuth powder to obtain a particularly thick reflecting surface. She repeated this method with more-refined bismuth powder, which was passed through a wire sieve, and the finer grain size resulted in a more even surface. In her fourth experiment, she duplicated Bohring's so-called dry process by utilizing a larger bismuth content, stronger glue, and a glass sieve, but also let the bismuth slurry dry before applying it. In summarizing her experiments, she noted that all the bismuth slurries produced a darker color and less reflective surface than was obtained with a pulverized bismuth.

### Schiessl's references to fourteenth- and fifteenth-century recipes

In the 1980s, Ulrich Schiessl described reconstruction attempts by Wibel, Buchner, and finally Bohring, though he does not mention proportions of ingredients (Schiessl 1983). In connection with investigations into the etymology of the word *bismuth*, as well as its material scientific explanations, Schiessl also cited studies of Emil Ploss (1959:317–21) and fourteenth- and fifteenth-century recipes, offered as additional reconstruction possibilities.

### Summary

All efforts to reconstruct the bismuth painting technique since 1891 were based on the subjective interpretations of each author, and they did not reflect historical analysis or sources. The initiative for technical examination came from art historians and museologists who had rediscovered the bismuth boxes and their unusual decorative technique.

---

## Considerations of the Bismuth Technique by Historians

In an 1876 article, August von Eye became the first cultural historian to concern himself with bismuth-decorated boxes (von Eye 1876:1–3). He believed that the boxes had been neglected because of

the inconspicuous shape in which they have been passed on to our time. Imbued from the very beginning with very little artistry and created as usable objects that preferably after much handling were tossed aside, these objects were not able to be cleaned or restored due to their technique of manufacture, and therefore were unable to draw the attention of science or collectors.<sup>4</sup>

It is evident from von Eye's comment, that his evaluation placed the boxes in a lower value range, a placement compounded by the fact that the boxes could not be cleaned or restored because knowledge of their manufacturing technique had been lost.

Art historian Jakob Stockbauer makes a value judgment in the article, "The Wooden Boxes in the Bayerischen Gewerbemuseum" (1887), and in a later three-volume work he asks, in reference to bismuth-decorated boxes, whether "the mineral which today we call bismuth should be brought into connection with this art at all" (Stockbauer 1893:243). In the first guide to the Museum für Kunst und Gewerbe in Hamburg, Justus Brinckmann (1893) discusses bismuth paintings and reports on Wibel's reconstruction attempts.

In 1905, Hans Stegmann, an early art historian, wrote, "A thin layer of bismuth powder was applied onto a thick chalk ground, the usual paintings ground, and then burnished by means of a polishing stone until a metal-like reflective surface appeared." Of its quality, he says that "from beginning to end this painting technique cannot lay claim to an art work," and adds, "It is an easy step from this relatively cheap and simple technique to an even cheaper one." He refers to small boxes with applied colored engravings or woodcuts with similar decorative patterns but not bismuth ground (Stegmann 1905:37).<sup>5</sup>

Ernst Darmstaedter (1927) appears to cite Buchner's essays in addition to Wibel's, listing both procedures in abbreviated form in his article. In 1928, art historian Heinrich Kohlhausen writes of bismuth-decorated boxes that the chalk ground merely has bismuth powder sprinkled onto it and then is burnished with a polishing stone (Deneke and Kahsnitz 1978:1126). Hans Lanz (1969) describes the process slightly more extensively: "The metal was applied in powder form onto a glue-like binder on a chalk ground and then burnished with an agate to an evenly smooth silvery reflecting surface."

Horst Appuhn, art historian, describes this technique (1986:791), writing that "the ground of multicolored tempera paintings consists of bismuth, a metal that, after being ground, is applied with a binder onto the usual chalk ground and then is polished with an agate." Bernward Deneke, a folk historian, noted in 1969 that "the metal was applied onto the chalk ground in a powder and reflected through the varnish layers" (Deneke 1969:141–42) and, like Kohlhausen, did not mention the binder.

## Summary

In reviewing published art historical material concerned with the technology of bismuth painting, it is evident that modern research was initiated in 1890 by Brinckmann; this is not surprising considering the number of objects to which he had access or of which he was aware, although many were difficult to identify. Confirmation of a bismuth ground raised questions about technique from chemists and others, and this eventually led to numerous investigations.<sup>6</sup>

With the article from von Eye and the push by Brinckmann for chemical investigations, museologists moved bismuth boxes into the lime-light, although bismuth painting was considered artistically insignificant. The authors of the first articles were especially uncertain about bismuth's value as a material, and even Stockbauer presented bismuth painting as a relatively cheap and simple technique. Cultural historians, by contrast, presented the recipes for producing the bismuth ground in very few sentences but in a schematic fashion, wishing perhaps to convey an idea of the difficulty of this process.

---

## Current Research into Bismuth, Based on Historical Sources and Analytical Methods

### Preliminary comments

Traditional bismuth boxes offer a rich spectrum of research hypotheses with regard to makers, purchasers, distributors, and centers and periods of manufacture, which in turn allow for evaluation by art historians and acceptance into museum collections. Other considerations are manufacturing techniques, ornamentation, themes of decoration, and, last but not least, composition of the bismuth ground and the colors used in the decoration.

In the study carried out by the author, the assistance of specialists was needed in order to satisfactorily investigate the various aspects of the bismuth ground and paint, and staff in various museums with bismuth box collections provided support. Technical difficulties were encountered first with the identification of the bismuth ground and then with the interpretation of retouchings and overpainting. Scientists assisted with microscopy and ultraviolet microscopic analysis, but due to cost factors, only limited total reflectance X-ray fluorescence analysis (TRFA) could be carried out.<sup>7</sup>

### Evaluation of recipes from the fourteenth to the eighteenth century

Among numerous authoritative handwritten manuscripts from the fourteenth and fifteenth centuries are recipes for inks that optically resemble silver ink but that have bismuth as the base. One of these manuscripts indicates how this ink may be applied to wood. These recipes give rise to the following questions:

1. Are there extant historical artifacts that demonstrate the use of these recipes?
2. Is it possible to duplicate these recipes without the factual knowledge of their manufacture?
3. Is modern bismuth different in appearance from historic bismuth?
4. How closely do the recipes of Wibel, Buchner, and Bohring re-create the original manufacturing techniques?

In order to answer these questions, the various recipes must first be examined in detail.

The earliest recipe for the manufacture of “silver ink” is found in a 1384 manuscript (Library of the Germanischen Nationalmuseum 1384):

If you want to write so that it looks like silver, take a powder that is called bismuth. Pulverize it on a stone with some egg white or with gum arabic, as a pigment, and then mix it with the same gum arabic to an ink consistency that runs well out of the pen nib. Then rub it with a tooth so that it comes out clear and fine just like good silver.<sup>8</sup>

Most recipes state that they can be used “as a good ink,” and only a few indicate the possibility of use as a paint medium. In one fifteenth century manuscript (Library of the Germanischen Nationalmuseum 15th c.:sheet 4v), it is stated that

if bismuth is being applied to wood with a sponge or by other means, then you have to be careful [this is mentioned explicitly] that the mixture does not



contain too little gum arabic as there exists the danger of quick drying, or conversely it could become either dry or hard if it contains too much gum arabic. [This is followed by two recipes.]

In this case we are certainly looking at a recipe for a bismuth ground that would have been used for one of the traditional boxes. The recipes for the manufacture of the silver inks and for the paint ground are identical. In all the recipes, gum arabic is the binder for the bismuth; only one author (the one just quoted) deviates, offering a recipe that recommends a binder of “defatted cow’s or heifer milk combined with a good clean glue” (author’s translation).

Recommendations for producing bismuth powder are to “take bismuth and rub it with a little stone” (Library of the Germanischen Nationalmuseum 15th c.:sheet 4v) or to “take bismuth and pulverize it in a dry manner on a stone” (Historisches Museum 15th c.:202) or, “if you want to temper bismuth, grind it with water” (Bayerische Staatsbibliothek 15th c.:207r). Most mixtures rely on the prepared powder, however, and say little about the size of the granules. These short recipes often give directions on how to store or clean the mixtures.

In addition to these recipes from the fourteenth and fifteenth centuries, books from the sixteenth century mention other mixtures containing bismuth. These books could be considered handbooks for artists, craftsmen, and paint experts, and they have a strong connection to alchemy. In most cases, the purpose of the recipes is to increase the value of an artifact. In this context, one may note that *Argentum musicum* is often included in these handbooks. Recipes direct the working of tin, bismuth, and mercury into a writing medium, with gum arabic in water.

Contrary to earlier recipes for bismuth, those of the sixteenth century always add other elements, such as tin, sulfur, or ammonia, as a base for the mixture.

### Analyses and interpretation of historic sources by Mack

As part of this study, and as an attempt to reconstruct bismuth painting technique at the Germanic National Museum, microscopy was used to examine and analyze cross-section samples to learn more about the layer buildup. Electron microprobe analysis of samples from two boxes with differing paint techniques—most likely from different workshops—showed that in both cases the bismuth paint was of high purity. Therefore, sixteenth-century recipes could be excluded as a basis for these boxes, since they would have contained tin, mercury, sulfur, or ammonia in addition to the bismuth. Bismuth painters of the sixteenth and seventeenth centuries would not have used printed recipes but rather handwritten notes passed down from the previous centuries. This process is testimony to the long-term effect of recipes, often relayed and learned repeatedly through practical application.

Wibel’s 1890 investigative techniques are unknown; however, his results regarding the bismuth content differ very little from current analyses. He talks of almost pure bismuth, in which only traces of lead, and perhaps antimony and arsenic, are present. It may be, however, that the color layer of the box contaminated the sampled bismuth ground. Accordingly, Oliver Mack of the Germanic National Museum carried out a number of tests on bismuth ground, the results of which are reported in

the following. Microchemical analysis of cross sections from painted beech artifacts shows that the ground was made of glue and chalk, although the number of layers could not be determined. To carry out microchemical analysis of the binder, a cross section was stained for proteins with fast green dye; the chalk ground underneath the bismuth ground stained with equal intensity. A similar analysis of a cross section of a reconstruction produced by the Wibel method showed that the protein stains were uneven. This seems to indicate that Wibel's method does *not* recreate the original technique; in addition, it is difficult to achieve a highly polished surface with his technique, as would have been the case with the traditional box. It was also concluded that the chemical techniques of Buchner and Bohring must be excluded because they are too contemporary, as well.

### Reconstruction efforts by Mack

A number of the historical recipes assumed that pulverized bismuth would be used; others listed pulverizing by means of a stone. Following these instructions, Mack attempted to grind bismuth with different types of stone, using bismuth that had been purchased as an alloy. He quickly noticed that small (ideal) particles barely separated from the dry stone, and he found it possible to decant dry bismuth into a vessel in which the various particles could be separated in water and would settle according to their weight. After stirring the solution and waiting for the powder to separate from the larger (undesirable) particles, it was possible to decant the smaller particles floating on top. The point at which the smaller particles could be siphoned off varied with the intended use of the mixture (i.e., ink for a pen requires finer bismuth powder than does the flat application of paint layers or ground). The bismuth slurry made in this process shows the same qualities as the chemically made bismuth slurry described by Bohring.

The results raise the question of whether the *dry method*, incorporating Wibel's and Bohring's use of a glass plate and binder, should be renamed *mechanical method*, and whether the *wet method*, using as its base a chemical reaction, should be renamed *chemical method*.

Historical recipes indicate that the binder for bismuth powder is almost exclusively gum arabic. After the bismuth slurry has been combined with the gum arabic, the resulting stable, homogeneous slurry can be applied to a chalk ground—onto a large area on paper or as drawn lines—and polished with an agate. The color differences found in the various tests and described in more recent literature are visible only in the unburnished bismuth and are determined by particle size of the bismuth. The smaller the particles, the darker the color value (and the stronger the amount of binder); the stronger the bismuth foam, the darker the color. It is difficult to discuss objective color differences in burnished layers, probably due, among other factors, to the time difference between the grinding of the bismuth and its application onto the surface. What is noticeable, however, is that a small bismuth surface, approximately 3 cm<sup>2</sup>, appears more silvery than a larger one.

### Buildup of the paint layers

With few exceptions, the bismuth painters used beech as their substrate. The surface was soaked with glue, then coated with two to four layers of chalk ground, followed by the bismuth layer, which was usually coated with a transparent layer. Paint layers applied above these were generally

coated with a second lacquer or varnish. One or both of these coatings—usually only the lower one—may have been stained, although they could also have discolored with age. There is, however, mention of numerous recipes for a gold-colored lacquer in historical sources, such as a 1596 art technique book by Tobias Scheibell that refers to “a varnish layer of silver which appears like gold” or “a gold color on silver, tin and copper.”

The paint may have been applied in one or several layers. Two or more layers are often found if, for example, red or green colors were used; on numerous boxes displaying decorative leaf or garland motifs, the white leaves were first painted and a green lacquer was then applied over them. Indeed, the uneven application by brush of the green paint resulted in a range of different color effects. Mayr (1977:72ff.) mentions an extensive color palette determined on the basis of microscopy and analytical methods, but she does not divulge full details.

Due to cost factors associated with TRFA, samples from only one box<sup>9</sup> could be analyzed in the current study. This analysis confirmed the presence of the following pigments: azurite, vermilion, saturn red, lead white, and copper green. The outer sides of this box have a gilded ground for the decorative painting, whereas the inside has a bismuth ground and, in isolated areas, a silver ground. This box is certainly exceptional in that gold and silver metals are found along with bismuth. The outside of another decorative box, which was executed in the typical method of bismuth painting, also has a gilded ground, painted out partially with bismuth along the borders and on the collars (Fig. 3). Others with grounds of multiple metals may be found, and they will need further investigation.

### Bismuth paint in a fifteenth-century manuscript

The considerable number of recipes for inks that, according to historical sources, used bismuth to simulate silver, necessitated a search for historical manuscripts that might contain these inks. Mayr's 1977 study of a fifteenth-century Bible<sup>10</sup> indicated that the metal layers in the colored etchings were made of bismuth. Inquiries to experts at numerous state libraries in Munich unearthed no manuscripts with either decorative painting or writings in ink that contained bismuth. Visual and microscopic examination of the Bible yielded opinions that the dark metallic and reflective areas in the paint might be bismuth, or that it might also be silver or an alloy of tin, zinc, or lead. Electron-dispersive X-ray microscopy (EDX) indicated that the samples contained almost 100% bismuth.<sup>11</sup> This analysis proves the use of bismuth paint on paper in the fifteenth or sixteenth century.

---

## Conclusion

As a result of these studies, for the first time, the author and coworkers have been successful in both reconstructing a bismuth surface following historical recipes and, through analysis of fourteenth- and fifteenth-century manuscripts, pinpointing the technique that most closely follows the old manufacturing techniques.

The examination of bismuth decorative objects indicates that the presence of bismuth, as well as gold and silver, or the combination of gold with bismuth, enhances the appearance of the object, and it also has provided insight into the technical know-how of the bismuth artist. The assumption that bismuth was used as a substitute for silver will need to be reevaluated in this new context.

The study has also confirmed, for the first time, the use of almost pure bismuth for decorative painting on paper in the fifteenth or sixteenth century.

---

## Acknowledgments

Alexandra Bersch, Museum für Kunsthandwerk (Museum of Arts and Crafts) in Frankfurt, facilitated the use of scientific equipment; it was on her initiative that the otherwise costly total reflectance X-ray fluorescence analysis could be carried out. Oliver Mack, from the Germanic National Museum in Nuremberg, addressed scientific questions and helped to bring them into the practical realm with technical equipment available to conservators.

---

## Notes

1 Housed in the Museum für Kunst und Gewerbe (Museum of Arts and Crafts), Hamburg. Inventory no. 1890 413.

2 This is an old nomenclature for  $(\text{BiO})\text{NO}_3$  and is approximately 70 g of metallic bismuth.

3 See also Mayr 1984.

4 See also Deneke and Kahsnitz (1978:1119).

5 See also Deneke and Kahsnitz (1978:1137).

6 Brinckmann states in the annual report of the Museum für Kunst und Gewerbe:

The paint ground of bismuth paintings: this work was initiated by the Administration for the Arts and Applied Arts. Its purpose was to establish the nature of the ground of the so-called "Bismuth paintings." During this investigation, the body of questions grew substantially so that the end result was an extensive publication which seemed very desirable and which therefore appeared in print in the *Jahrbuch der Wissenschaftlichen Anstalten*.

7 This was facilitated by Alexandra Bersch, restorer of paintings and sculptures at the Museum für Kunsthandwerk in Frankfurt.

8 Author's translation is from Old German.

9 In the collection of the Museum für Kunsthandwerk, Frankfurt. Dated 1552 or 1557. Inventory no. 6784.

10 In the collection of the Tiroler Landesmuseum, Innsbruck. Inventory no. F.B. 129.

11 The author took part in this examination, along with restorers Gerdi Maierbacher-Legl (Munich) and Michael Klingler (Innsbruck). Scientific analysis was carried out by Karl Nigge, technician at the Department of Material Science and Technology of Metals at the University of Erlangen/Nuremberg, using a Raster electron microscope equipped with an EDX spectrometer.

---

## References

- Appuhn, H.  
1986 Kleine Kästchen mit Malerei auf Wismutgrund. In *Die Renaissance im deutschen Südwest*, vol. 2, 791–801. Exhibition catalogue of the Baden-Württemberg. Karlsruhe: Landesmuseum Karlsruhe.
- Bayerische Staatsbibliothek  
15th c. Manuscript Clm 20 174. Munich.
- Bohring, L.  
1963 Wismut für heutiges Gestalten. *Maltechnik* 2:107–12.
- Brinckmann, J.  
1893 Zur Technik der Wismutmalerei. *Kunstgewerbeblatt*, NF 3:(27–29).

- Buchner, G.**  
 1908 Ueber Wismutmalerei. *Bayerisches Industrie- und Gewerbeblatt* 13:121–22.
- 1910 Wismutmalerei. *Bayerisches Industrie- und Gewerbeblatt* 14:135.
- 1923 Wismutbelag für Wismutmalerei. In *Hilfsbuch für Metalltechniker*, 3d ed., 259–60. Berlin: Verlag Justus Springer.
- Darmstaedter, E.**  
 1927 Wismutmalerei: Kultur des Handwerks. *Amtliche Zeitschrift der Ausstellung München: Das Bayerische Handwerk*, 298–301. Munich: Ausstellung München.
- Deggeller, S.**  
 1963 Wismut und die Geschichte der Wismutmalerei. *Maltechnik* 2:33–38
- Deneke, B.**  
 1969 Wismutmalerei. In *Bauernmöbel: Ein Handbuch für Sammler und Liebhaber*, 141–42. Munich: Keyersche Verlagsbuchhandlung.
- Deneke, B., and R. Kahsnitz, eds.**  
 1978 *Zur Person: Das Germanische Nationalmuseum Nürnberg 1852–1977. Beiträge zu seiner Geschichte*. Munich and Berlin: Deutscher Kunstverlag.
- Herrmann, C.**  
 1977 Ein Beitrag zur Geschichte und Technik der Wismutmalerei. Diploma diss., Institut für Technologie und Malerei des Staatlichen Akademie der Bildenden Künste, Stuttgart.
- Historisches Museum**  
 15th c. Manuscript 12 45. Bern.
- Lanz, H.**  
 1969 Kästchen mit Wismutmalerei. In *Schweizerische Volkskunst*, ed. Robert Wildhaber, 42–46. Opladen, Switzerland: Friedrich Middelhaufe.
- Library of the Germanischen Nationalmuseum**  
 1384 Manuscript 3227. Nuremberg.
- 15th c. Manuscript 141 871. Nuremberg.
- 1596 Manuscript 98077. Nuremberg.
- Lippmann, E. O. von**  
 1930 Die Geschichte des Wismuts zwischen 1400 und 1800. *Forschungen und Fortschritte: Nachrichten der Deutschen Wissenschaft und Technik* 28(6):362–63.
- 1933 Nachträge zur Geschichte des Wismuts. *Chemiker-Zeitung* 1:4.
- 1953 *Beiträge zur Geschichte der Naturwissenschaften und der Technik*. Vol. 2. Weinheim: Verlag Chemie G.m.b.H.
- Mayr, K.**  
 1977 Wismutmalerei. Diploma diss., Meisterschule für Konservierung und Technologie an der Akademie der Bildenden Künste (Master School for Conservation and Technology), Vienna.
- 1984 Wismutmalerei. *Restauratorenblätter* 7:153–71.
- Ploss, E.**  
 1959 Kleinere Mitteilungen: Wismut (eine etymologische Studie). In *Archiv für das Studium der neueren Sprachen und Literatur*, 317–21. Brunswick, Berlin, and Hamburg: Westermann.

- Schiessl, U.  
1983 *Techniken der Fassmalerei in Barock und Rokoko*. Worms, Germany: Werner'sche Verlagsgesellschaft.
- Stegmann, Hans  
1905 Die Holzmöbel des Germanischen Nationalmuseums. In *Mitteilungen aus dem Germanischen Nationalmuseum*, 18–38. Nuremberg: Verlag des Germanischen Nationalmuseums.
- Stockbauer, J.  
1887 Die Holzkästchen im Bayerischen Gewerbemuseum. *Kunst und Gewerbe: Zeitschrift zur Förderung deutscher Kunstindustrie* 21:324–30.
- 1893 *Geschichte der Technischen Künste*. Vol. 3. Stuttgart, Berlin and Leipzig: Union Deutscher Verlagsgesellschaft.
- Sutter, J.  
1963 Wismutmalerei und ihre Technik. *Maltechnik* 2:39–43
- von Eye, J. L. A.  
1876 Wismutmalereien im germanischen Museum. *Anzeiger für Kunde der Deutschen Vorzeit*, NF 1 (23):1–3.
- Wehlte, K.  
1967 *Werkstoffe und Techniken der Malerei*. Ravensburg: Otto Maier Verlag.
- Wibel, F.  
1891 Beiträge zur Geschichte, Etymologie und Technik des Wismuths und der Wismuthmalerei. In *Jahrbuch der Hamburgischen Wissenschaftlichen Anstalten*. Vol. 8, 3–25. Hamburg: Lütcke and Wulff.

# Japanning in Seventeenth- and Eighteenth-Century Europe

## A Brief Discussion of Some Materials and Methods

Margaret J. Ballardie



Figure 1  
Detail of alligatoring as the result of copal varnish applied to the eighteenth-century shellac varnish surface of a japanned panel.

**I**N ART CONSERVATION, it is essential to have a thorough knowledge of the original materials and techniques used to decorate the surfaces of the objects that come into the conservator's care; if these materials are not known and a varnish is used in the conservation treatment that is incompatible with the existing varnishes, disastrous results can occur. See Figure 1 for an example of the type of surface that can result from such incompatibility. For this reason, among others, it is important to understand and to recognize the different techniques used in lacquerwork and japanning.

When one considers the surface finishes that are described under the heading "Japanning," the situation is very confusing. For example, an eighteenth-century box decorated with chinoiserie and coated with a spirit varnish would be described as japanned. A Victorian box with a black oil-based ground and mother-of-pearl decoration would also be described as japanned, as would a tinware box whose black painted surface had been heated in an oven (i.e., *stoved*). To understand what these surfaces have in common, it is necessary to look at the history of the word *japanning*.

The word came into use during the seventeenth century, when lacquerware from China and Japan rose to the height of fashion—black and gold lacquer from Japan becoming the most admired and sought-after. Since that time, the words *lacquer* and *japan* have been used generally and indiscriminately to describe varnishes and paints that produce a glossy surface. In short, japanning is the Western re-creation of Far Eastern lacquerware.

By the end of the seventeenth century, European craftsmen were aware of the techniques and materials used in Far Eastern lacquerware. The following quote from Dossie's *Handmaid to the Arts* (1796:282) makes it clear that *urushi*, the toxic raw material for the lacquer resin, had been brought to Europe but was rejected for safer and more familiar resins.

The true japan black Lacquer (which is now frequently brought from China) has been sometimes used for the varnishing of snuff boxes, cups, and all such pieces made of paper or saw-dust. But this lacquer, being the concreted juice of the toxicodendron tree, its poisonous qualities are almost constantly fatal to those who work with it for any length of time and sometimes even on very slight contact with it. Such a momentous inconvenience, together with the tediousness of dispatching the work, on account of its great tardiness in drying, being extremely good reasons against its use, it is much more

advisable to employ the common kind of varnish, which when managed judiciously, may be rendered nearly both as beautiful and durable, without either the danger or the difficulty attending the other.

Dossie incorrectly reports that urushi comes from *Rhus toxicodendron*, a sumac tree, and is fatal; in fact, it is extracted from another sumac, *Rhus verniciflua*, which can induce a serious rash that may require hospital treatment. However, his rejection of urushi for its difficult drying requirements correctly pinpoints why it was not widely adopted. Indeed, craftsmen of the period experimented with familiar materials, such as resins, as well as the more recently imported shellacs from India, in attempts to duplicate the look of oriental lacquerware. Eventually they discovered that by building up layers of clear varnish over a colored ground—or incorporating designs such as Chinese figures, fanciful animals, and flower forms within the layers of varnish (using gold or other metal powders)—they could create surfaces similar in appearance to those of genuine oriental lacquer panels.

In many European countries, publications appeared that described the techniques, materials, and designs used to re-create the fashionable Chinese-influenced decorations of what came to be known as chinoiserie; of these, *A Treatise of Japaning and Varnishing* by John Stalker and George Parker (1688) is probably the best known. Because it was written for amateurs, the instructions are concise, though often buried in flowery asides, as the following example illustrates (Stalker and Parker 1971:16):

Lay all your Colours and Blacks exquisitely even and smooth; and where ever mole-hills and knobs, asperities and roughness in colours or varnish offer to appear, with your Rush sweep them off, and tell them their room is more acceptable to you than their company. If this ill usage will not terrifie them, or make them avoid your work, give them no better entertainment than you did before, but maintain your former severity, and with your Rush whip them off, as often as they molest you.

---

## White Japan

Stalker and Parker also include a recipe for “White Varnishing or Japan” (1971:21–23), variations of which appear in other literature. The varnish used for white japan is a mixture of resins they called “Best White Varnish.” If the recipe is reproduced carefully according to the instructions, the result is very attractive, with the translucent look of ivory. Throughout the process, the secret of success is to allow plenty of drying time between layers and to keep the layers very smooth.

Note that the format of the following recipes<sup>1</sup> and directions (Stalker and Parker 1971:10–11) has been reorganized for clarity.

### White Varnishing or Japan

#### Ingredients

- 1 oz. [31.1 g] isinglass dissolved in 30 oz. [852.36 ml] water, to produce isinglass size
- Flake white (lead white)
- Potato starch, cooked in water to thin paste (1 oz. [31.1 g] starch to 1 pt. [568.26 ml] water)<sup>2</sup>
- Best White Varnish (see recipe below)



*Application*

- Gesso ground: Mix 20 oz. [568.26 ml] isinglass size with whiting to the consistency of light cream. Apply three coats. When dry, rub back the surface until very smooth.
- Flake white layer: Mix remaining 10 oz. [284.12 ml] isinglass size with flake white. Apply at least three coats. When dry, smooth the surface gently.
- Starch layer: Apply two coats.
- Best White Varnish layers: Apply up to twelve coats.<sup>3</sup>

**Best White Varnish**

*Ingredients*

Stalker and Parker	Adaptation by the author
1 lb. Gum Sandrick	1 lb. (454 g) sandarac
1 oz. Gum Mastic	1 oz. (28.5 g) mastic
3 oz. Venice Turpentine	3 oz. (87 ml) Venice turpentine
1½ oz. Gum-Capal	1½ oz. (42.5 g) copal
½ oz. Gum-Elemni	½ oz. (14 g) elemi
½ oz. Gum-Benzion or Benjamin	½ oz. (14 g) benzoin
1½ oz. Gum Animae	1 oz. (28.5 g) copal (substituted)
½ oz. White Rosine	½ oz. (14 g) rosin

*Preparation*

In separate glass containers, dissolve the following groups of resins in the volumes of alcohol indicated:

copal and resin	10 fl. oz. (290 ml) alcohol
benzoin and Venice turpentine	10 fl. oz. (290 ml) alcohol
sandarac and mastic	30 fl. oz. (870 ml) alcohol
elemi	5 fl. oz. (145 ml) alcohol

After the resins have dissolved completely (about twelve hours), filter the solution and mix carefully together.

**Note**

<sup>a</sup>The author found that six layers proved sufficient.

<sup>b</sup>The original solvent was “spirits of wine.”

Two further versions of the white japan recipe may be found in the eighteenth-century literature. Although one—in the *Polygraphic Dictionary* (1735), under the heading “Japan”—is almost identical to that of Stalker and Parker, the second—in Dossie’s *Handmaid to the Arts* (1796:314)—shows significant differences. Dossie maintains that the gessoed ground should not be applied because it causes the japanned ground to “crack and fly off in flakes.” Applied in its place is a layer of “clear-coat” or a “clear-col,” which is a hot size with the addition of a small amount of whiting. When dry, it is rubbed smooth and, although it fills only the pores of the wood, can produce an excellent surface. Following Dossie’s directions, the flake white and the starch mentioned in the white japan recipe are mixed together while dry and bound with mastic varnish. Then, what is now virtually a paint is applied in thin layers; once these are absolutely dry, the surface is gently rubbed smooth.

It is important to note that the Best White Varnish was, in fact, not white or colorless; the resulting layers tended to be pale ochre or umber, and they darkened over time. These white japan surfaces were often decorated with designs inspired by Chinese porcelain and were

*Figure 2*

Schematic diagram of white japan layers. Note the watercolor decoration layer (pigments with gum arabic) between the Best White Varnish layer and the top varnish layer.

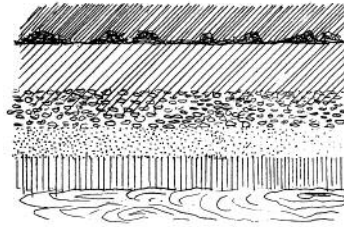

Painted with pigments bound in gum arabic. The surface then would be finished in layers of pale shellac rubbed smooth, and polished with a mixture of oil and rottenstone (Fig. 2).

---

## Blue Japan

Another noteworthy recipe from this period is for blue japan. Various blues are mentioned, including Prussian blue and blue verditer, but one of the most interesting involves the use of smalt (i.e., cobalt-blue glass that has been pulverized). Smalt was produced principally in Holland, although some was also manufactured in London.

Stalker and Parker's recipe for blue japan (1971:23–24) is much like that for white japan, except that blue pigment is mixed with the lead white, and a layer of smalt replaces the starch. Blue japanned surfaces consist of a layer of blue japan, followed by layers of white varnish.

### Blue Japan

#### Ingredients

- Gum-water: Mix 1 oz. [31.1 g] whitest gum arabic with  $\frac{3}{4}$  pt. (15 fl. oz. [426.18 ml]) water. When the gum has dissolved, strain it through muslin.
- Flake white: Grind lead white with the gum-water.
- Smalt is mixed with isinglass size.

#### Application

Mix the lead white and smalt together (the proportions depend on the depth of blue required) to the consistency of common paint. Apply the mixture to the surface. Wait until the paint layer is perfectly dry, then apply another layer. Repeat three or four times. If a darker blue is required, apply more layers using only smalt and isinglass size. Put aside for two days, then apply seven or eight layers of white varnish. Allow at least a week for drying before polishing the surface (Fig. 3).

As with white japan, recipes for blue japan changed over time. For example, isinglass was used as the binding media for the pigments in Stalker and Parker's 1688 formulation, but by the end of the eighteenth century gum elemi and poppy oil, heated together, were used as a binder, making the preparation closer to that of commercial paint.

*Figure 3*

Schematic diagram of blue japan layers, using smalt. Mastic varnish would cause less discoloration, but it is not as durable.

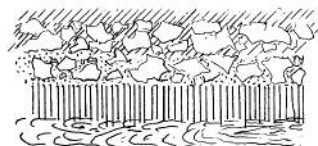

Blue japan may have been covered with a colored varnish, rather than the white varnish in the preceding recipe, to create special color effects. To cite one striking example, the author has seen a long-case clock entirely decorated with smalt that was varnished over with a transparent golden varnish, producing a beautiful translucent green (Fig. 4). Assuming that the gold is the original color of the varnish, not a product of aging, it is important to note that pigment and varnish colors were used in separate layers to produce the desired effect. This is very often the case with japping techniques, and this possibility must be checked before any varnish is removed during conservation treatment.

---

## Raising Techniques

An essential element of japped work decorated with chinoiserie is the raising of portions of the decoration so that figures, mountains, buildings, and so on appear in relief. Raised decoration was often gilded with either gold leaf or gold paint.

A number of different recipes for raising techniques have been published, providing a range of different approaches. Stalker and Parker, for example, use gum arabic as the binding medium in their recipe (1971:33), advising that whiting and red bole be ground together with “strong Gum-Arabick-water” until the mixture is “as fine as butter.” The resulting paste may be built up slowly in layers to achieve a desired shape, or it may be cut, scraped, and carved. The instructions offer numerous warnings about the care that must be taken with this technique, and the chapter ends with this claim: “With these ingredients, joined to Art and Skill, it is possible to make a paste so hard, so stubborn, that a violent stroak with a hammer can neither break or discompose it” (1971:35).

One later recipe includes whiting and pigment bound in seed lac. Recipes in most modern publications call for gesso, and they usually stipulate that the underlying japped surface be scored through to the supporting ground.

---

## Sprinkling

Among the many other decorative techniques used in japping is *sprinkling*, in which metal powders of varying particle size were sprinkled onto the varnish while it was still wet, then sealed with another coat of varnish. Fragments of gold leaf might similarly be applied to the surface and

Figure 4

Cross section of a sample taken from a long-case clock (ca. 1730, Canterbury). Smalt is shown in the center, supported by the varnish layer. A section of the gold decoration can be seen in the thin layer at the top.

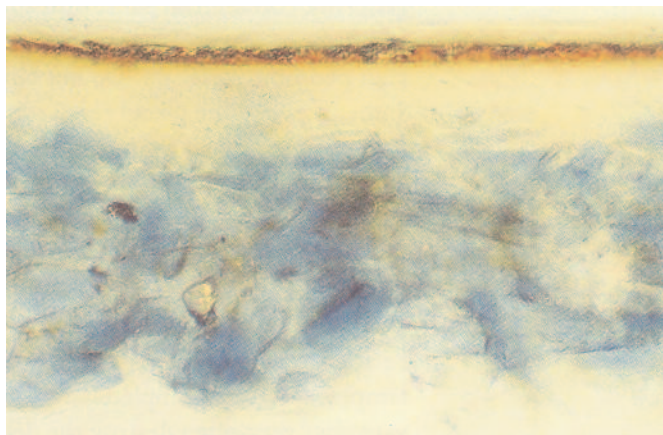

*Figure 5*

Schematic diagram of aventurine layers. The visual effect is created by holding the speckles between layers of shellac or other varnish.

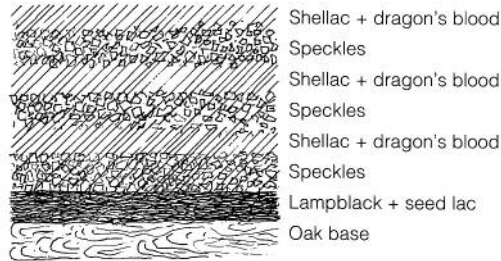

suspended between layers of varnish. In *A Treatise of Japaning and Varnishing*, this technique is called “Speckles” or “Strewing” (Stalker and Parker 1971:31–32). Strewing refers to the application of gold leaf. When used to create borders of dense speckles, the technique is also known as *aventurine*.

Sprinkling was developed to create a traditional lacquerwork technique, and it involves two categories of metal: (1) *powders*—brass dust, silver dust, green gold, powdered tin, and copper dust; and (2) *speckles*—flaked metal leaf, gold, silver, and copper. There is an endless variety of application techniques for metal leaf and powders. Moreover, the metals behave differently in various mediums (e.g., gum-water, varnishes, and shellacs).

The sprinkles were applied in a variety of ways that range from a single, light sprinkling to a thick layer over a previous layer of bronze powder. Furthermore, three or four layers of speckles may be separated by layers of shellac that had been colored with gamboge or dragon’s blood. Indeed, in many early recipes, thirty to forty layers could be applied, including the basic gesso ground, the foundation coats of japan, raised decoration, gilding and watercolors, and the many finishing coats of varnish or shellac. Between all these coats, the surfaces have been smoothed and polished (Fig. 5).

---

## Some Modern Developments

During the nineteenth century, japanning recipes altered dramatically. Oil varnishes and asphaltum began to be used, reflecting the shift to industrial processes in response to increased use of japanned ware during the Victorian period. Commercial paints with descriptive names such as Lacquer, Japlac, or Japan were produced.

Further changes occurred during the 1920s, when chinoiserie achieved renewed vogue in furniture, clothes, and interiors. In Paris, lacquer artisans produced some beautiful pieces utilizing genuine urushi; but generally, commercial paint with a high varnish content was used. In the newspapers, advertisements appeared with headlines such as “Let us Japan your bedroom suite” or “Do not buy new! We can Japan your furniture.” Sometimes antique pieces received this colorful treatment, and it is possible nowadays to find an eighteenth-century object with a twentieth-century painted surface that, after seventy years of wear, can become visually confusing.

---

## Conclusion

Conservation of complex examples of all types of japanned surfaces must be approached with the greatest care, as many of these surfaces have been tampered with or completely renewed, and solvents used to remove the varnishes very often destroy the decoration held within those varnishes.

For example, shellac varnishes are often very difficult to treat with solvents, as they readily absorb the solvent, and the result may be that suddenly the entire layer dissolves. Another important consideration is that the seventeenth- and eighteenth-century varnishes were not clear and colorless; although desired, such varnishes were then unobtainable.

Very few articles have been written on conservation of japanned objects. Activities of the ICOM Interim Lacquer Group<sup>3</sup> address Far Eastern lacquer, as well as Western lacquering techniques (i.e., japanning); however, those of us in the group are a small minority in the vast conservation field.

---

## Notes

- 1 Measurements are given in British imperial units and converted to metric.
- 2 The author was advised that potato starch was the starch most likely used in seventeenth-century Europe.
- 3 The Interim Lacquer Group is part of the Furniture and Lacquer Working Group of the ICOM Committee for Conservation.

---

## References

- Dossie, Robert  
1796 *The Handmaid to the Arts*. 2d ed. London: J. Nourse Bookseller.
- Polygraphic Dictionary*  
1735 London: Hitch and Davis.
- Stalker, John, and George Parker  
1971 *A Treatise of Japaning and Varnishing*. 1688. Reprint, London: Alec Tiranti.

## Painted Harpsichords

*Laurence Libin*

**I**N THEIR ROLE AS STATUS SYMBOLS, musical instruments are prized for their looks as well as their sounds; and of all instruments, keyboard types expose the largest surface for display. For example, pipe organs with monumental architectural facades appeal as much to the eye as to the ear in expressing institutional pride. On a smaller scale, stringed keyboard instruments, such as the harpsichord, clavichord, and piano, have important functions as furniture glorifying their owners' taste through luxurious decoration inside and out (Fig. 1). Such ornamentation reached a peak of elaboration during the late Renaissance and Baroque period, when costly harpsichords, spinets, and virginals were custom painted in distinctive, often meaningful schemes. After 1557 in Antwerp—a leading center of production—the Guild of Saint Luke embraced both harpsichord makers and painters, who were sometimes related by marriage and collaborated side by side in fulfilling commissions (O'Brien 1990:12–14). Owing to a different guild structure, eighteenth-century Parisian harpsichord builders and their customers could rely on independent decorators, such as a particular M. Doublet, who advertised between 1775 and 1783 that “he is known by the particular care which he takes in order that the instruments which one confides to him do not run the dangers to which they are too often

*Figure 1*  
Michele Todini, harpsichord (outer case),  
ca. 1670, Rome. Length of raised portion,  
272 cm. The Metropolitan Museum of Art,  
Crosby Brown Collection of Musical  
Instruments, 1889 (89.4.2929).

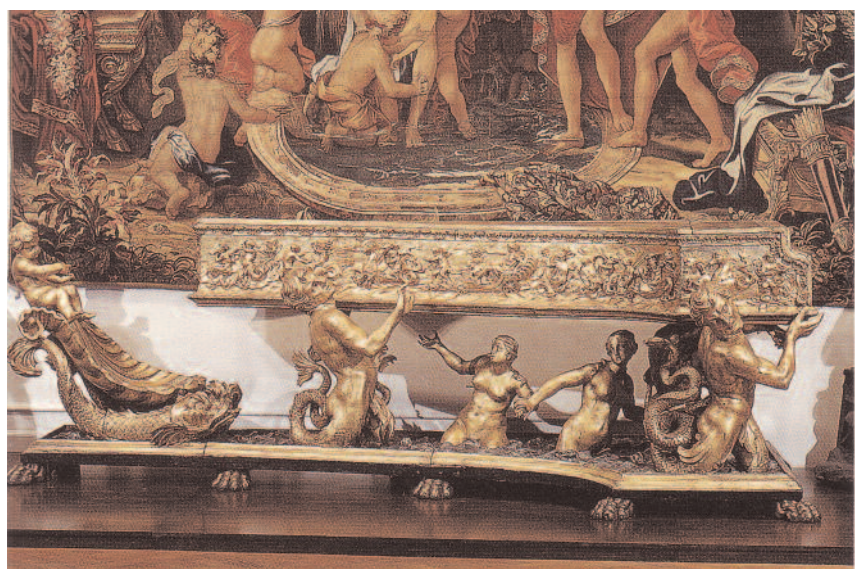

exposed in other ateliers” (Germann 1980:437).<sup>1</sup> Though often done anonymously, harpsichord painting attracted artists even of the stature of Rubens and Jan Breughel. The tradition continues today in the work of painters who decorate replicas of antique harpsichords by contemporary makers.

In comparison, the standard black concert piano of the past hundred years looks austere; its plain exterior is less costly and distracting than fancy painting would be. Furthermore, the modern piano’s internal iron frame renders the surrounding wooden case acoustically inert, whereas the harpsichord’s essentially all-wood construction allows the case to vibrate somewhat, contributing to the overall tone quality. Characteristically thin-walled Italian harpsichords, built nearly as lightly as guitars, are usually housed in a separate protective outer case that can bear an extraordinary burden of gesso, gilding, and paint; the lidless, usually plain cypress instrument can be removed from its outer case and placed on a table to enhance its resonance. Only exceptionally are thin-walled Italian instruments (unlike those with an integral, false “outer” case) loaded with any external decor other than elegant moldings and, occasionally, intarsia and ivory buttons.

The Northern European harpsichord, by contrast, is more heavily constructed and so does not have a separate outer case; thus the instrument itself ordinarily is painted. For this discussion, Flemish and French harpsichords represent the decorative mainstreams.<sup>2</sup> These instruments typically display three distinct zones of painting: the case walls (including a separate flap enclosing the keyboard end) and lid exterior; the lid underside; and the soundboard (Fig. 2). The exterior usually sports a conventional decor like that seen on contemporary or somewhat earlier furniture, ranging from plain or gold-banded monochrome to marbling, or even fantastic chinoiserie. Complementary designs often appear inside around the keyboard and soundboard areas, as well as on the removable rail that prevents the jacks from rising too high. In order not to weaken the case (which can be constructed of hardwoods and softwoods of various species), any elaborate carving is confined to the stand.

The underside of the lid, revealed when the lid is raised for a performance, can be spectacular. One scene might occupy the entire surface; or the front section, if separately hinged, might have a separate picture facing the player when this section is folded back. Many Flemish lids incorporate a sententious Latin motto on exotic greenish wood grain–printed paper (Mactaggart and Mactaggart 1985). French examples commonly

*Figure 2*  
Hans Ruckers, octave spinet, 1581, Antwerp.  
W:80.2 cm. Plan view, most strings and jack  
rail removed. The Metropolitan Museum of  
Art, Gift of B. H. Homan, 1929 (29.20).



Figure 3

Henry Hemsch, harpsichord, 1736?, Paris. L:238 cm. Plan view with strings, mechanism, and keyboards removed. The soundboard decoration is essentially original. Museum of Fine Arts, The Edward F. Searles Musical Instrument Collection, 1981 (81.747).



exhibit an evocative landscape, *fête galante*, or even a theatrical scene, sometimes done in oil on canvas that is applied to the wood (Libin 1983).

Because of its protected position, the lid interior escapes much of the dirt and wear that endanger the exterior, though the portion nearest the keyboard may be smoked from candles that flanked the music desk or scratched by the lid prop stick. Frequent opening of the lid by dirty hands also may have deposited localized grime. Because eighteenth-century builders often enlarged and redecorated older instruments, lids should be examined for signs of piecing out, especially along the curved side. Complete overpainting sometimes obscures an earlier motto, which may be visible in raking light or through X rays. Stands, too, are sometimes reworked or replaced in conformity with later styles. Vestiges of original decoration, including printed paper in Flemish instruments, can be hidden behind the keyboard end blocks, under jack-rail brackets, and elsewhere. This evidence must be documented and preserved.

The most problematic area for conservators is the soundboard, the instrument's chief acoustical radiator, which—unlike the case and lid—must be painted before the wire strings are installed (Fig. 3). Treatment of this crucial vibrating surface requires an understanding of its complex structure and function. Especially if an antique instrument is to be rendered playable (a very controversial operation), conservation of the soundboard painting should involve the assistance of an experienced harpsichord restorer who can deal with loose components, open cracks, and the unstringing and restringing of the instrument. The following overview of the soundboard is necessarily superficial but is meant to alert conservators to common pitfalls.

A French- or Flemish-style harpsichord soundboard (Fig. 4) typically comprises half a dozen or more separate edge-joined boards, each up to about 15–20 cm wide, of medium- to fine-grained, quartersawn spruce or fir. While still in the rough, individual boards are selected for desirable tonal properties by tapping; resonant ones are preferred. Some old sources recommend wood split from the north-facing side of a trunk, excluding heartwood as too stiff and coarse (Hubbard 1965:201–4, 273–76). Ideally, the grain should be clear and uniform, but considerable variation occurs with no discernible effect on tone. Once glued up, the soundboard is planed and scraped (not sanded) to a graduated thickness of about 2–4 mm, thinnest where maximum flexibility is required—as in the treble and corners—and thicker where structural or acoustical needs dictate greater stiffness—as in the bass. This subtle but tonally vital topography is difficult



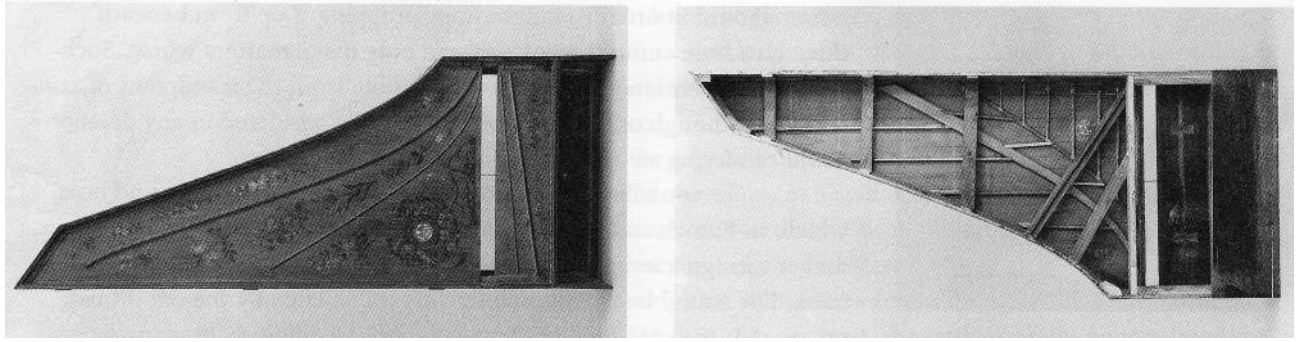

*Figure 4*

Louis Bellot, harpsichord, 1742, Paris. L.:238.7 cm. Plan view with strings, tuning pins, key-board, mechanism and bottom removed. The Metropolitan Museum of Art, Crosby Brown Collection of Musical Instruments, 1889 (89.4.1218).

*Figure 5*

Louis Bellot, harpsichord, as in Fig. 4. Bottom view showing soundboard ribbing, transverse cut-off bar, four-foot hitch-pin rail, and traces of previous alterations.

to discern once the soundboard is installed, since the enclosed bottom of the case blocks access for measurement. Removing an intact bottom should be avoided.

Various structures are applied to the soundboard before its installation, commonly in dry winter weather. These include the thin, curved hardwood bridge, which bears the strings and conducts their vibration to the soundboard; and the ribs and transverse cut-off bar, which reinforce the soundboard from beneath and help define its vibrating modes (Fig. 5) (Kottick 1985). The shape, mass, and placement of these elements critically affect the soundboard's elasticity and nodal lines, and hence the instrument's tone. The ribs, which transect the soundboard's grain, must be strong enough to inhibit its tendency to warp and crack yet light and flexible enough not to damp vibration. The heavier, more rigid transverse cut-off bar prevents excessive deformation of the soundboard forward of the bridge and, in so doing, isolates a triangular portion of the soundboard surrounding the sound hole.

To provide tonal and dynamic variety, most harpsichords have two or three sets of strings, commonly including one set roughly half the length of the other(s) and pitched an octave higher. These higher, so-called four-foot strings pass over a separate bridge and hitch onto pins embedded through the soundboard into a stiff rail attached beneath. The four-foot hitch-pin rail acts like the cut-off bar to further define the vibrating area around the bridges. The longer, so-called eight-foot strings hitch to pins in an elevated rail that edges the soundboard along the curved side and angled tail; this hitch-pin rail and corresponding molding along the straight side or spine help secure the soundboard to liners beneath. The front edge of the soundboard fastens to the belly rail, of which the inside top edge may be partly cut away in the extreme treble to afford more vibrating area.

Obviously, correct stringing and string tension are fundamental to tone quality and duration, but these factors leave the maker's control once an instrument is sold. A common defect in harpsichords that have been too heavily strung or pitched too high is wavy distortion of the soundboard caused by its sinking under the bridges and pulling up over the four-foot hitch-pin rail; this action simultaneously exerts excessive compression and tension on different areas of the soundboard. In extreme cases, such distortion causes the four-foot strings to buzz against the soundboard. This defect will not ordinarily correct itself, even if an instrument is properly restrung or even unstrung altogether. Bad as this seems, trying to remove



Figure 6  
Henry Hensch, harpsichord, as in Fig. 3.  
Detail of maker's insignia in sound hole and  
surrounding decoration, before restoration.

a soundboard in order to flatten it, or propping it up from beneath through a hole cut in the bottom, can only make matters worse. Such drastic intervention is generally indefensible from the standpoint of conservation, though other factors must also be considered in any decision about rendering an antique instrument playable.

The soundboard's last salient feature is its circular sound hole, which, in French and Flemish harpsichords, typically incorporates the maker's insignia in a cast lead rose (Fig. 6); rarely is any other material used. The sound hole's location in the area isolated by the cut-off bar means that the rose's weight is tonally inconsequential. In many harpsichords, the sound hole is decorative rather than acoustically essential because openings in the belly rail allow equalization of air pressure inside and outside the soundbox. Indeed, in two 1778 spinets by Pascal Taskin (one at Yale University, the other in a New York private collection), the presence of a sound hole is merely suggested by a painted circular ornament incorporating Taskin's monogram.

Holes made by positioning-pins sometimes pierce the soundboard under or alongside the bridges. Finely scribed layout lines may also have aided bridge positioning. Other faint guidelines are sometimes found, especially encircling the sound hole and along borders, scribed to assist the painter. As mentioned earlier, old harpsichords were sometimes enlarged and remodeled; therefore, redundant scribe lines and plugged holes may reveal former bridge and hitch-pin positions. These features should be documented whenever found.

Despite their ribbing and barring, soundboards ordinarily do crack along the grain as a result of environmental changes. Unlike loose bridges and ribs, small cracks are seldom fatal to the sound, but they readily enlarge if not repaired. Larger cracks are often shimmed, but shims can cause further cracking and compression in the neighboring wood. Shimming and other repairs may also require inpainting and overpainting that can obscure the original decoration, as well as alter the character of the original wood surface by exaggerating earlywood and latewood corrugations (Mactaggart and Mactaggart 1977). Very often during enlargement or repair work, ribs will have been moved or replaced and cracks reinforced from beneath through holes cut in the bottom or with the bottom removed. Such procedures represented common practice until quite recently. An opened bottom at least affords opportunities for inspection and measurement, which is necessary for accurate replication of an instrument.

The strings are secured to the tuning pins, which are embedded in a thick hardwood plank. The strings pass over this so-called wrest plank, and then over a stationary bridge, called the *nut*. The wrest plank may be veneered on its top surface with soundboard stock, so that although not resonant, it appears to be an extension of the soundboard and may be painted to match. Scribe lines, redundant holes, and other revealing marks may also be encountered here. Occasionally, string-gauge markings are inked on the nut or, more rarely, on the soundboard bridge, showing where wire diameters and materials changed. Antique harpsichords rarely retain original or even very old strings, but, because gauge patterns may survive string replacement, whatever wire is present should be measured (and kept in order, if removed); and any extraneous fragments, such as broken loops, should be labeled and preserved. If tuning pins must be removed—for example, to clean stains from the wrest plank—these, too, should be kept in order, as their diameters may be graduated. Hand-forged

tuning pins often have rough surfaces, and their flattened tops may be unexpectedly soft or brittle; they must be extracted cautiously with a snugly fitting socket wrench called a *tuning hammer*, which may have to be specially fabricated.

Unlike the exposed surface of a violin, a soundboard is not meant to be handled, and therefore, as a rule, protective varnish does not appear as an original feature of Northern European (excluding English) instruments. Although several eighteenth-century sources describe soundboard varnish, even stating that it improves sound, this idea may be fanciful (Hubbard 1965:216, 219–20). At most, the builder might have primed the upper surface with a light coat of (preferably dewaxed) shellac, gum arabic, gum senegal, or dilute glue before delivering the unstrung instrument to the soundboard painter, who might prefer to size just the areas to be painted in order to keep the colors from bleeding. Due to differential darkening over time, any spot sizing not covered by paint, or old spot varnishing over the design, might now show up as an unintended halo around the decoration. Varnish over an entire soundboard painting is probably a later addition. Varnished bridges are particularly suspect; the coating can grab the strings, making tuning difficult, and can prevent firm string bearing against the bridge and pins. However, the acoustical effects of soundboard varnishing have not received scientific study, and the inherent risks of removal might outweigh potential benefits.

In the traditions under review, soundboard paintings usually involve two kinds of design elements: (1) multicolored flowers, leaves, fruits, and small fauna—such as birds and bugs—painted in flat gouache in a water-soluble binder, such as gum arabic (not in egg tempera, as is often stated [Mactaggart and Mactaggart 1979:60]); and (2) curvilinear blue borders and arabesques, typically somewhat three-dimensional and containing smalt. Borders and arabesques were likely executed first, then an opulent floral ring around the rose, followed by the rest of the design, which might have been laid out first in chalk, with care taken in placement to cover blemishes in the wood. If, as Sheridan Germann suggests, the painter used mussel shells as containers for small quantities of paint, it would have been hard to keep the unused paint wet for long, hence the painter would probably try to use as much of one color as possible at one time with little blending: all the blue first (for borders and arabesques), then all the red, yellow, and so on. In contrast to lid paintings, the soundboard palette was limited and work went quickly (Germann 1980:445, 447).<sup>3</sup>

Individual soundboard painters can often be characterized by their design vocabularies and techniques, as these tend to remain consistent among soundboards from the same painter, who may have worked for several builders over decades. Printed herbals and similar pattern books provided models for certain forms, some of which seem to have been symbolic. Conventional images of resurrection—for example, a moth or a dead trunk sprouting new leaves—are not uncommon, though their significance might be lost on most viewers (Fig. 7). Placement of cherries next to a cherrywood bridge, or of an insect near a woodworm hole, suggests a visual pun. In general, seventeenth-century soundboard paintings look opaque, as though their crowded, rather stiff, self-contained, and flatly rendered flowers were applied as *découpage*; occasional white underpainting reinforces this effect (Germann 1980:453). Except when imitating this style, as on an enlarged or faked Flemish soundboard, later French soundboard painting typically looks more energetic, integrated,

*Figure 7*

Henry Hemsch, harpsichord, as in Fig. 3. Detail of soundboard painting adjoining bridges and four-foot hitch pins, before restoration.

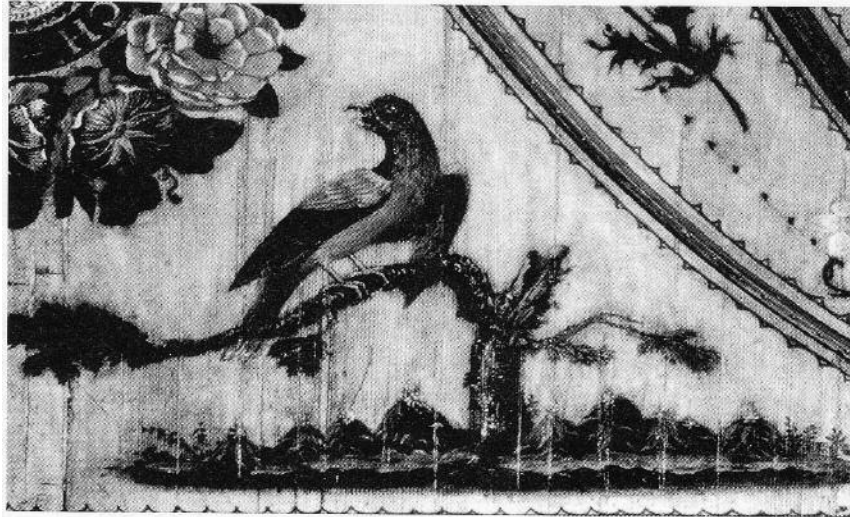

and transparent—sometimes to the extent of revealing the underlying wood (Germann 1994).

Because of its delicacy and tendency to bleed, such water-based paint preferably might be cleaned by dry methods without much rubbing. Liquids can raise the early growth grain of wood, which has been compressed by scraping, and thus alter the character of the original surface. Solvents can have unanticipated effects on resins in the wood, and the possible acoustical effects of solvent penetration in soundboards have not been studied.

In the past, restorers often overpainted worn areas of decoration and altered the size and location of painted elements to cover soundboard repairs; for example, a leaf or the feathers of a bird might have been elongated to cover a shim. Shims and patches reflect light differently from their surroundings if the grain of the wood is not properly oriented, and sanded wood accepts paint differently from scraped wood. To hide such discrepancies, inexpert soundboard repairs often involve wholesale staining and varnishing, which, like bad overpainting, can be reduced or removed if technically feasible and aesthetically necessary. Any such intervention must be considered in relation to conservation of the whole instrument—whether returning it to its presumed original state or to a later state, to which some past alterations might be integral. The intervention must also be considered in light of the instrument's significance and intended function.<sup>4</sup>

---

## Acknowledgments

The author thanks Walter Burr and Berta Burr, Sheridan Germann, Pamela Gladding, Grant O'Brien, and A. Hardy Schlick for valuable advice and suggestions.

---

## Notes

1 See also Germann 1981.

2 For a historical outline of various schools of harpsichord making and for further explanation of technical terms, see Hubbard 1965.

3 See also Germann and Odell 1978.

4 A fuller discussion of the conservation issues raised in this article can be found in Barclay 1993.

---

**References**

- Barclay, R., ed.  
1993 *Recommendations for Conservation of Musical Instruments: An Annotated Bibliography*. Comité International des Musées et Collections d'Instruments de Musique Publications No. 1. Paris: International Council of Museums.
- Germann, S.  
1980 Monsieur Doublet and his confreres: The harpsichord decorators of Paris, 1. *Early Music* 8(4):435–53.  
1981 Monsieur Doublet and his confreres: The harpsichord decorators of Paris, 2. *Early Music* 9(2):192–212.  
1994 The dance of flowers: The expression of gesture and energy in 18th-century French harpsichord decoration. *Midwestern Historical Keyboard Society Newsletter* 9(1):6–7.
- Germann, S., and S. Odell  
1978 Pleasing to eye and ear alike—The Jean Mari Dedeban harpsichord of 1770. In *The William A. Clark Collection*, 96–104. Exhibition catalogue. Washington, D.C.: Corcoran Gallery of Art.
- Hubbard, F.  
1965 *Three Centuries of Harpsichord Making*. Cambridge, Mass.: Harvard University Press.
- Kottick, E. L.  
1985 The acoustics of the harpsichord: Response curves and modes of vibration. *Galpin Society Journal* 38:55–77.
- Libin, L.  
1983 A rediscovered portrayal of Rameau and *Castor et Pollux*. *Early Music* 11(4):510–13.
- Mactaggart, A., and P. Mactaggart  
1977 Some problems encountered in cleaning two harpsichord soundboards. *Studies in Conservation* 22(2):73–84.  
1979 Tempera and decorated keyboard instruments. *Galpin Society Journal* 32:59–65.  
1985 The colour of Ruckers lid papers. *Galpin Society Journal* 38:106–11.
- O'Brien, G.  
1990 *Ruckers: A Harpsichord and Virginal Building Tradition*. Cambridge: Cambridge University Press.

# Floral Painting on Early Eighteenth-Century American Furniture at The Metropolitan Museum of Art

*Frances Gruber Safford*

THE METROPOLITAN MUSEUM OF ART in New York has in its collection of American furniture a particularly strong representation of case pieces from the early decades of the eighteenth century that are ornamented with decorative painting—a total of fifteen examples from New York and New England. In conjunction with research for a collection catalogue of early Colonial furniture, these objects became the focus of a special project to investigate the technical aspects of the painting, an area largely unexplored in the study of such furniture. The author felt that a knowledge of the materials and methods used in the decoration was essential for a better understanding of these pieces. One aim was to determine as closely as possible the original appearance of the painted surfaces, which we see today in a more or less deteriorated and altered state. Another aim was to learn to what extent ornamentation belonging to various distinct stylistic groups differed in the paint and techniques used.

Furniture decorated solely or primarily with ornamental painting, which in most instances featured floral designs, first appeared in America around the turn of the eighteenth century. At that time, pieces with carved or applied decoration in the Mannerist style were being outmoded by furniture in the newer, early Baroque fashion. On seventeenth-century Mannerist furniture, paint formed only part of the decorative scheme; it was applied selectively to distinguish particular elements of the carved or applied ornament. Thus, furniture with floral painting was novel, and it appears to have had great appeal as a colorful, cheaper alternative to high style, early Baroque japanned or veneered pieces.

---

## A Chest of Drawers from the Boston Area

The most elaborate decorative scheme of any piece studied is on a chest of four drawers from the Boston area; this piece combines graining with floral ornamentation that is contained within simulated panels on the drawers (Fig. 1). With its drawer fronts divided by and built up with deep mitered and beveled moldings, this joined chest of drawers is a late example of the Mannerist applied-ornament style as it evolved in and around Boston, after being introduced by London-trained joiners in the 1630s. The late expression of that style is indicated by the incorporation of certain newer design elements, such as the surrounding of the drawer openings with an applied astragal molding—a feature that reflects the influence of early Baroque case furniture, which was first produced in Boston in the late

*Figure 1*

Chest of drawers, 1700–1720. H:102 cm.  
 Massachusetts, Boston area. The proper right  
 side is partially cleaned. The Metropolitan  
 Museum of Art, Gift of Mrs. J. Insley Blair,  
 1948 (48.158.11).



1690s. It is the most elaborate example from a group of more than twenty chests of a similar format.<sup>1</sup>

## Design

The painted ornamentation appears to have been influenced by early Baroque furniture, with the exception of the undulating vine motif on the shallow drawers, which has a long tradition of usage in the seventeenth century and earlier. A striking feature of this newer style is its expanses of highly figured veneers. The bright graining on the drawer fronts suggests such veneers, although it may be drawing upon an earlier tradition of simulating in paint the exotic woods that were favored on Mannerist furniture at the highest level of production. Dark semicircles painted on the side panels recall the round or oval figure of so-called oyster shell veneer, unknown on American furniture but found on English pieces of the last three decades of the seventeenth century. (Probate inventories indicate that by the mid-1690s, inlaid furniture was present in New England, which means it must have been imported.) This type of veneer—which is often quite light in color, except for its dark figuring—is frequently found on English furniture in conjunction with brightly colored floral marquetry set against a dark ground. The decoration on the chest of drawers was apparently meant to evoke such fashionable furniture both in its designs and in the tones of the backgrounds on the drawers.

The three leaves at the base of the painted sprigs may well represent a misunderstood fleur-de-lis, particularly as they are drawn on the top drawer. Variations in the execution of the sprigs, such as in the shape and number of petals in the flowers, suggest that a basic pattern may have been drawn or scribed to serve as a general guide, but it was not followed carefully in the painting. The left and right sides of each of the two center drawers are mirror images of one another; the vines on these drawers are similar in configuration but vary in decorative detail and color. As these two drawers are structurally interchangeable, both have been in the upper position; the arrangement originally intended is not entirely certain, but



Figure 2  
High chest of drawers, 1700–25. H:131.4 cm.  
Probably Boston, Massachusetts. Detail  
of drawer fronts. The Metropolitan Museum  
of Art, Gift of Mrs. Russell Sage, 1909  
(10.125.709).

the placement of the drawer with the black vine above the drawer with the white one is probably correct.

While the vines—a traditional motif—must have formed part of the painter's regular repertoire, the sprigs, in all likelihood, were taken directly from a print or drawing, as the manner in which they are depicted certainly suggests copying from a line design. The sprays are entirely outlined in black, and colors are applied within the confines of the lines. Neither this manner of delineation nor a similar spray motif is encountered elsewhere. Flowers generally suggestive of those that terminate these sprigs, in that they have a dark inner portion of the petals surrounded by a light band, can be found in Stalker and Parker's *A Treatise of Japaning and Varnishing* (1960:pl. 13 and others), but the flowers on this chest are more distinctively rendered. The only related flowers known to be painted in a similar manner and whose designs resemble japanning are on a high chest of drawers, also from the Boston area, in the Metropolitan Museum's collection.<sup>2</sup> One of the two types of flowers depicted on the latter piece has inner petals outlined in black, punctuated with dashes of color, and surrounded by a band of solid color that in some instances, as in Figure 2, is filled with dots. What connection there may be between the painting on these two pieces is unknown. There are no other similarities, and the painting is by totally different hands—that on the high chest being much more proficient.

### Scientific analysis

The chest of drawers is made of red and white oak (frame, top, and drawers), eastern white pine (side and back panels and certain applied elements), and yellow pine (remaining applied elements). At the time the technical investigation was begun and samples were taken, the painted surfaces were covered with a heavy, discolored coating (as can be seen on the proper left side in Figure 1).<sup>3</sup> Bold lines of graining were partly visible where the coating was worn thin on the drawers, and specks of intense color stood out from the otherwise muted tones in a few small, chipped areas. Such tantalizing evidence had long aroused the author's interest and curiosity, and indeed the scientific analysis of this piece proved to be particularly rewarding. It revealed that the decoration under the coating, and overpaint in several areas, was surprisingly colorful. Cleaning of the painted surfaces was begun in August 1994, and early results can be seen in the photograph. The effect of this painting when new—with its multicolored floral motifs, surrounded by bright orange or green moldings, with all colors strong and fresh—must have been dazzling. The number of different pigments is the greatest found on any one piece in the study. In approximate descending order of the extent of their use, they are carbon black, iron-earth red, yellow ochre, red lead, lead white, copper green, vermilion, and realgar.<sup>4</sup>

Samples taken from the front and rear stiles show that the ground layer of black paint, which contains fine, closely packed particles, is thin.<sup>5</sup> It has flowed into the wood pores and closely follows the contours of the wood surface. The same black appears to have been used to paint the pattern of arcs on the side panels, where the black overlaps and mixes into the red ground layer. The red ground contains an iron-earth pigment. This red may have once covered the top, as well; a red pigment that has not



been analyzed was detected under magnification in some of the wood pores across the entire surface.

On the top and bottom drawers, iron-earth red, which appears to be the same as that on the case sides, forms the ground coat of the panels with the sprig design. It also colors the center plaques holding the escutcheons, and it was used for the graining. Wavy, "trial" brushstrokes of this red appear on an unexposed surface of the bottom drawer. Conceivably, they were made just prior to the application of the red wavy lines of graining on the mitered and beveled strips of the two deep drawers. The ground of those bevels is yellow ochre, and the red of the graining mixes into the yellow background layer. The center plaques on the two middle drawers were also originally yellow ochre, but were later overpainted with red. Trial swirls of yellow ochre were applied to the back of the chest, where they never received a coating. This indicates that this paint was initially lighter and less brown than it now appears on the drawer fronts. Both the yellow ochre and the iron-earth red ground layers are considerably thicker than the black on the frame. Orange applied moldings mediate between the yellow beveled strips and the red panels. The orange consists of red lead mixed with lead white. Because of extensive paint losses, the original brightness of those moldings is hardly discernible in the photograph.

On the two shallow drawers, the ground of the floral decoration is orange—the same red lead and lead white mixture found on the moldings of the deep drawers—and was later overpainted with red. The applied moldings surrounding the orange panels are painted with a copper green, possibly verdigris. A cross section shows blue-green particles in a binder that looks slightly yellow. The green paint—originally strong and bright—has suffered considerable losses and appears almost entirely black. This is due, in part, to the discoloration of the pigment and binder, but is also due to the fact that only a few areas of the deteriorated and discolored coating above the paint had been removed at that point in the treatment.

In the floral elements, green is employed only for buds and flower centers in the sprigs on the top and bottom drawers, and for leaves on the bottom drawer. Prior to cleaning, this green was virtually indistinguishable from black. The dark lines in the sprigs, the dark vine on a shallow drawer, and the dots on the white vine are black paint; it is similar to the black on the frame but applied much more thickly. The red decorative accents in both the sprigs and the vines are vermilion, and the orange ones are realgar. The realgar must have differed in hue and intensity from the orange made from red lead and lead white in order to warrant the use of this noxious pigment.<sup>6</sup>

## Conclusion

The artisan who decorated the chest of drawers worked with commercially available pigments at the basic level of a painter-stainer.<sup>7</sup> This person was adept at graining, and had a good sense of color and design, but may not have had much practice in rendering flowers. This individual may or may not have been the joiner who built the piece. The artisan was engaged in a level of production that in an urban context such as Boston, provided a cheaper, more conservative alternative to fashionable veneered, inlaid, or japanned pieces, and in a rural environment might have been the most stylish available.

## Five Chests from Connecticut

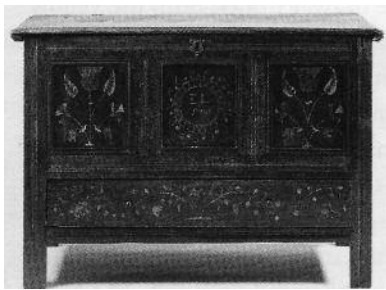

*Figure 3*  
Chest with drawer, dated 1705. H:82.9 cm.  
South-central Connecticut. The Metropolitan  
Museum of Art, Gift of Mrs. Russell Sage,  
1909 (10.125.29).

The ornamentation on the Connecticut chests discussed here differs markedly from that on the chest of drawers detailed previously, both in type of flowers and in painting method. As will be shown, four of the chests, illustrated in Figures 3–7, are recognizably similar in their designs and technique and can be considered the work of a single major school of painting. This appears to have been the principal style of ornamental painting in south-central Connecticut for about three decades and must have encompassed several craftsmen or shops. A fifth Connecticut chest exhibits a different style of floral painting and underscores the fact that the ornamentation on the four other pieces represents a distinct tradition.

### A chest dated 1705

The chest with drawer inscribed “EL 1705” (Fig. 3) and four related chests with dates ranging from 1704 to 1706 are an early manifestation of the major south-central Connecticut style. What may be the earliest example, a 1704 chest at the Art Institute of Chicago, is partly carved and partly painted.<sup>8</sup> In form and construction, these dated pieces are seventeenth-century joined chests; more specifically, except for a few structural details, they are built like chests from a shop tradition that has been associated with Peter Blin of Wethersfield, Connecticut, which were decorated with applied ornamentation and carving. Such chests typically have carving on the outer front panels, consisting of a central stalk with a large, stylized tulip and leaves, smaller tulips, and sometimes thistles; and some examples of a ring of tulips enclosing initials on the middle panel.<sup>9</sup> The composition of the painted motifs on the front panels of the 1705 chest closely parallels this arrangement.

The chest is made of oak (frame and drawer) and yellow pine (panels). The ground coat is a thin red-brown layer containing iron-earth pigment. With the exception of a few small elements, the floral designs on the facade are all delineated first in a thick coat of lead white, over which the colors—vermilion and copper green—are then applied in a relatively thin layer. The colors either entirely cover the white undercoat, as is the case in the solid green or red leaves on the drawer front, or, more often, are used as detailing that stands out against the white. Varied, lively effects are achieved with this limited palette through numerous parti-color combinations: the longitudinal division of small leaves into two colors on the drawer; thick green veins over red hatching on the leaves flanking the thistles; a diaper pattern in green with dabs of red in the interstices on the thistles; dots on the tulips and within the circular band of the center panel; and on the carnations, green cross-hatching on the lower petals, followed by a tier of petals in a solid, deeper green, and white center petals with red stripes.

The green areas vary in color, and samples indicate that visible differences are due not just to a greater or lesser degree of darkening with age or variations in the thickness of the remaining paint layer or finishes covering it, but are due also to an intentional use of two shades of green. Two distinct green paints were found: one, a deeper blue-green consisting of copper-green pigment particles and binder; the other, a lighter green mixture of copper green and lead white. Some variations in the brightness of the paint on the front panels, particularly the white, are due to a thicker or thinner residue of a glaze layer of uncertain date, which consists of tiny red particles in a medium that has turned to brown. Because the glaze

*Figure 4*

Chest with drawer, 1705–25. H:48.6 cm.  
Connecticut, Guilford-Saybrook area. The  
Metropolitan Museum of Art, Gift of Mrs.  
Russell Sage, 1909 (10.125.16).



appears to have bound to much of the color detailing, it was left in place when the chest was cleaned in 1991 (Fodera 1991). Only traces of this layer remain on the drawer front, where the detailing is worn and there has been some restoration.

The red and green dots that speckle the framing members of the facade are painted directly on the ground. They were set off by wavy white lines, now mostly lost, that accented the shadow moldings. On the side panels, large leaves and flowers on thick stems issue from mounds indicated only by a short arc. They are executed in lead white, in a broadly brushed, rather gritty, and sometimes barely continuous application.

### Two “Guilford-Saybrook” chests

The chests in Figures 4 and 5 form part of a group of eighteen pieces of case furniture with a type of painted ornamentation that has long been associated with the area of the Connecticut shore extending from Guilford to Saybrook. The large range of decorative designs in this group—mainly flowers and birds—is more varied and far richer than that on any other American painted furniture of the period and encompasses the motifs on the front of the 1705 chest. In addition to the forms illustrated by these two pieces, the group includes a high chest of drawers, two joined chests of drawers, and numerous joined chests with drawers. The furniture in this group is made primarily of yellow poplar.

The principal designs used were firmly rooted in earlier traditions. The facades of the Guilford-Saybrook chests invariably show flowers or vines emerging from a central vase or mound. This device and the types of flowers depicted have a long history and were popular in numerous media throughout the 1600s. Although some of the flowers on these pieces may well have become part of the painters’ learned vocabulary, in all probability the original sources of the floral forms and birds were published designs. Beginning in the Renaissance, printed ornament designs adaptable for use in various media were in wide circulation, and flower and bird designs abounded. The bold design on the upper front of the chest on stand (Fig. 5) was undoubtedly taken from a printer’s device. It corresponds exactly to chapter headings found in several seventeenth-century English books. Designs incorporating those same motifs appear on numerous Guilford-Saybrook pieces and are exclusive to that group. On all but

*Figure 5*

Chest on stand, 1705–25. H:93.7 cm.  
Connecticut, Guilford-Saybrook area. The  
Metropolitan Museum of Art, Gift of Mrs.  
Russell Sage, 1909 (10.125.15).

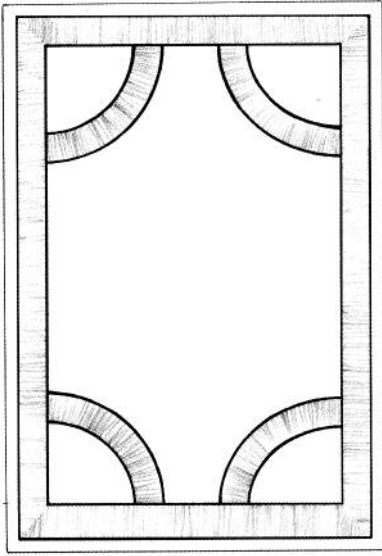

Figure 6  
Design on the top of the chest on stand  
shown in Figure 5.

this chest on stand and a joined chest with drawer at the Henry Ford Museum and Greenfield Village in Dearborn, Michigan, the roses and thistles have been arranged so as to make the composition totally symmetrical.<sup>10</sup> Several variations exist, suggesting the work of more than one artisan and the evolution of the motifs over time.

For the most part, the resemblance of this painted decoration to fashionable marquetry or japanning, which must have accounted for its popularity, lay in its bright colors and not in the motifs used. On the top of the chest, however, a painted border, now only partly visible, defines the perimeter and describes an arc inside each corner (Fig. 6). The border is formed of white dashes between red lines applied directly on the ground, and it resembles crossbanding found on early Baroque veneered furniture.<sup>11</sup>

Several decades ago, a Charles Gillam (or Guillam), who was living in Saybrook perhaps by 1703, was suggested as the maker of this furniture; however, no documentation is known that can definitively link him to the Guilford-Saybrook furniture (Trent 1994). It is likely that he was one of several joiners in the area who must have been interacting, given both the structural relationship between the 1705 chest and related dated chests and some of the Guilford-Saybrook pieces, and the similarities in motifs and painting technique not only between those two groups but also in a further group discussed later and represented by a chest with the initials “MD” (Fig. 7).

The painting technique used on the small board chest with drawer (Fig. 4) and the chest on stand (Fig. 5) is the same as that on the facade of the 1705 chest: designs laid out in white, over which detailing—primarily in red and green—is applied in thinner layers in a stylized, fanciful manner. The chest with drawer (Fig. 4) is made mainly of yellow poplar. Its lively design is painted on a black ground. Like the iron-earth ground of the 1705 chest, this ground seems to have little binder (Fodera 1991, 1992). The layer of lead white that defines the design is thick enough to appear slightly raised above the background. Some of the finer color details are deliber-

Figure 7  
Chest with drawer, 1715–35. H:84.5 cm.  
Connecticut, probably Guilford-Saybrook  
area. The Metropolitan Museum of Art, Gift  
of Mrs. J. Insley Blair, 1945 (45.78.4).



ately worked directly on the ground, as is the case in the red dentiled edges of pairs of flowers on the front and in the delicate, feathery tufts on the sides. Green is applied only over white. Visually there are two shades, one bluer and deeper than the other; but because only one sample was analyzed, it is not known whether more than one green paint is involved. The one sample tested, from a bluish area, contained some lead white in addition to copper green. Two distinct red paints were identified: one contains vermilion with the addition of a lead pigment; the other appears to be a lead white with the addition of red lead or an iron-earth pigment.

A sample from the deep yellow center of the middle flower on the proper left side revealed the presence of orpiment;<sup>12</sup> however, no pigment was detected in a sample from an adjacent flower, where the area of yellow lacked clear boundaries. The samples were taken before the chest was cleaned in 1992. The cleaning removed most but not all of the discolored and uneven finish layers that obscured the designs and the brightness of the colors (Fodera 1992). As some of the yellow may still be imparted by yellowed varnish, with the limited sampling done it is difficult to know the extent that orpiment was used. Nevertheless, it seems reasonable to assume that orpiment was employed in the areas of yellow that are clearly demarcated, as in some petals and in the distinct yellow lines within the white fields surrounding the green and red on the tulips.

The floral motifs showed no previous restoration, and although there are some losses, the definition of the major elements by the use of color reads clearly. However, important questions about the original appearance of the decoration remain. Not only is it uncertain if all of the areas that now appear yellow were meant to be that color, but it is also unclear if elements that are currently white—such as some of the stems, small leaves, or edges of petals—were intended to be pure white or whether they have lost color detailing or an original glaze. A more general question that remains unanswered for all of the painted furniture of this period is whether the decorated surfaces were originally coated with a transparent varnish.

In spite of considerable wear and losses, the overall composition of the decoration on the facade of the chest on stand (Fig. 5) makes a strong, bold statement. However, the reversal of colors on identical motifs is no longer readily apparent, as on the upper drawer, where a pair of green inner leaves veined in red alternates with red outer leaves veined in green, or as in a similar reversal of colors on the center and outer crowns. Birds frequently ornament the sides of Guilford-Saybrook pieces, and no two are quite alike. The birds on this chest sport green tail feathers that are veined like leaves, in red.

The chest on stand is made primarily of yellow poplar. The black ground is similar to that on the small chest with drawer in Figure 4. Only one red (vermilion) and one copper green paint were identified on the chest on stand. The green, which in cross section shows blue-green particles in a medium that appears yellow, looks nearly black in some areas. The narrow red brushstrokes at the very top of the thistle and those in red and green in the tufted flowers on the lower drawer are applied directly on the ground. Cleaning of this chest at the museum in 1980 removed some of the discolored coatings that obscured details of the design; it also removed what appeared to be the deliberate painting out of certain elements, such as the pair of large leaves flanking the center crown. A layer of yellowed varnish of varying thickness remains on the

surface, in some areas going over losses. It is not clear if the varnish is entirely responsible for the variable brown yellow seen over most of the white areas. Analysis of two samples of brown yellow from the upper facade—one from the vine and the other from a small leaf—revealed that they contain mainly arsenic with only a trace of sulfur, far too little for all the arsenic to be present as orpiment. It is uncertain whether this layer is a glaze or a yellowed varnish containing arsenic, and its date is in question. In a sample from the bird on the proper right side, arsenic, a trace of sulfur, and some copper were detected in a brown glazelike layer that appears to be above a clear coating. Arsenic, but no sulfur, was also found in a yellow ochre layer on the chest in Figure 7.

### A late “Guilford-Saybrook” example

The shop that produced the board chest with drawer inscribed “MD” (shown in Fig. 7) appears to have been an offshoot of the main Guilford-Saybrook tradition. This chest differs structurally from the Guilford-Saybrook pieces in the use of pine as the primary wood and in the less rudimentary character of the dovetailing of the drawer, but the method of painting is the same. In this instance, the design in lead white with detailing in vermilion and copper green is executed on a yellow ochre ground. Only the upper left side of the chest now has a yellow tone, but yellow pigment was detected under magnification in the wood pores of all main surfaces, including the top, cleats, and moldings. The vines are very obviously formed from crisp compass curves. Virtually all the floral forms on the facade are variations and elaborations on a tripartite motif (be it leaves or a stylized lily) of the type seen next to the tulips on the chest with drawer in Figure 4. The leaves of the trees on the sides are a solid color—red, green, or white—and are uniform in size and shape. This is a more restricted, more formulaic design than the rich variety of motifs seen, for example, on the chests in Figures 4 and 5, suggesting a waning of the Guilford-Saybrook tradition. Several other case pieces with similar decoration on the front and sides are known. Among them is a small board chest with drawer that is inscribed with initials and the year 1730—another indication that the painting on the “MD” chest (Fig. 7) must be relatively late.<sup>13</sup>

### A Connecticut chest in another style

The ornamentation on another pine board chest with drawer in the Metropolitan Museum’s collection represents a different style of floral painting produced along the Connecticut shore. The decoration on this chest—which is one of several thought to have originated in the Milford, Connecticut, area—is also based on a conventional lily motif (Fig. 8).<sup>14</sup> The motif could have been abstracted from the floral designs seen on the “MD” chest, but the resemblance is probably purely coincidental, as the Milford chests differ significantly from the Guilford-Saybrook pieces in construction and in the composition and execution of the designs. On the front and sides of the museum’s chest, either the full motif (as in Fig. 8) or portions thereof are arranged on vines that tend to meander, and the effect is close to that of an overall pattern. The exact replication of forms indicates use of a template.

Paint losses on the chest are extensive. Only traces of lead white remain on the terminal fleur-de-lis and the pair of leaves at the base of the motif illustrated. The red, which defines the pair of large outer petals, is a

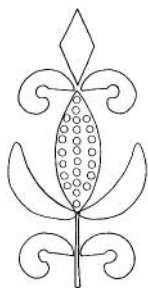

Figure 8  
Motif from a chest with drawer, 1720–40.  
H:92.7 cm. Connecticut, probably Milford  
area. The Metropolitan Museum of Art,  
Rogers Fund, 1934 (34.128).

mixture of red lead and lead white applied directly to the ground. The colored dots that decorated the white center petal appear to have been green on the front and red on the sides. The green has not been identified; no copper was detected in the one sample analyzed. The thin, dark ground coat on this piece is a mixture of black and red particles—probably a carbon black with a red-iron pigment and red lead. Whether this type of ground is peculiar to this piece or is characteristic of all the chests with similar decoration remains an open question until the paint on related chests in other collections has been analyzed.

---

## Conclusion

The investigation of the technical aspects of the ornamental painting on the Metropolitan Museum of Art's early eighteenth-century American furniture proved fruitful. As the body of knowledge initiated by this project is enlarged, it should become an increasingly valuable tool in the further study of such furniture. The project achieved two broad goals. First, it identified the pigments used in the painting, making it possible to much more accurately determine the original colors of the decoration on each piece. The analysis of the chest of drawers from the Boston area (Fig. 1) was especially rewarding in this respect. It brought to light a color scheme far more vivid than imagined, for one is accustomed to seeing painted ornamentation that is discolored and muted through age and later coatings. Second, the project demonstrated that individual schools of ornamentation appear to be defined not only by the nature of the designs but also by the technical aspects of the painting.

The floral painting on the aforementioned chest of drawers provides a marked contrast to that on the Connecticut chests, both in the type of flowers represented and in the manner of their delineation. While the type of floral ornament seen on this piece appears to be a unique survival, the flowers in the sprigs do bear some affinity to those seen in japanning. The general influence of professional Boston japanners on the painter-stainers and joiners of the area has yet to be assessed (as little research has been done on painted furniture from eastern Massachusetts), but it does appear to have had some effect on the depiction of flowers in this instance.

In the case of the four Connecticut chests painted in the same distinctive manner, one can speak of a recognizable school of painting, whose shop practices can be clearly differentiated from those that produced the ornament on the fifth Connecticut chest discussed. Although the group of four represents the work of several hands in their construction and ornament, they appear to be diverse expressions of the same or related tradition of painting. However, the exact source of this form of painting and the artisan who actually introduced it to south-central Connecticut are questions that remain to be answered.

---

## Acknowledgments

The author is greatly indebted to present and past members of the Department of Objects Conservation for the scientific investigation of the objects discussed in this article. Thanks go to Antoine M. Wilmering for spearheading the project on the painted surfaces and for supporting it throughout; Mark T. Wypyski for the pigment analyses; Keith Bakker for the macro-examination of the surfaces, the sampling, and the cross-sectional microscopy; and Mark D. Minor for additional helpful observations. The drawings are by Edward Di Farnecio.

---

## Notes

- 1 For the chest's fielded and painted side panels, see Schwartz (1976:15) and Safford (1980:353, pl. 1). The most ornate of the related chests is one at the Brooklyn Museum, Brooklyn, New York, which has fleurs-de-lis and small birds painted in black on a red or white ground, in addition to graining (Peirce 1976:1292); and one at the Henry Francis du Pont Winterthur Museum, Winterthur, Delaware (acc. no. 56.10.3), which retains only graining.
- 2 The high chest is also illustrated in Lockwood (1926:fig. 59).
- 3 For the technical analysis, cross sections were examined microscopically in visible and ultra-violet light, and pigments were identified by energy dispersive X-ray spectrometry. Virtually no identification of binders was undertaken. Conservation reports, including drawings of the cross sections, are in the object files of the Department of American Decorative Arts.
- 4 Realgar is an orange-red sulfide of arsenic and is poisonous. It is a mineral found in natural deposits and is related to orpiment (see note 12). See Harley (1982:125).
- 5 The black was not tested for all pieces in the study. Those samples that were analyzed did not give a reading and were assumed to be an organic pigment.
- 6 See note 4.
- 7 See Cummings (1971) for painter-stainers and 1684 painter's inventory, and Fairbanks and Trent (1982:449–53) for pigments identified in seventeenth-century Boston portraits.
- 8 For the dated chests at the Art Institute of Chicago, the Connecticut Historical Society (Hartford, Connecticut), and the Museum of Fine Arts, Boston, see Kirk (1967:nos. 18, 43, 45). The last chest in the group mentioned—at the East Hampton Historical Society (East Hampton, New York)—is illustrated in Graybeal and Kenny (1987:336).
- 9 For a typical carved chest, see Lockwood (1926:340). Through the years the author has examined all five painted chests and numerous carved ones to establish the structural relationship. This relationship recently has been examined in detail in Willoughby (1994). For an overall view of the Blin group and its attribution, see Schoelwer (1989).
- 10 For an example of the chapter heading and the chest at the Henry Ford Museum, see Fales (1972:figs. 23, 28).
- 11 For another chest with banding, see Fales (1972:fig. 27).
- 12 Orpiment is a yellow sulfide of arsenic. It is a mineral occurring in natural deposits in Europe and Asia and was known since ancient times. It is closely related to realgar and was disliked because of its noxious fumes. See Harley (1982:93–94).
- 13 The 1730 chest is in a private collection and unpublished.
- 14 The Metropolitan Museum's chest is unpublished. A chest with closely related decoration, at Historic Deerfield, Inc., in Deerfield, Massachusetts, is in Fales (1976:fig. 382). The attribution of this group to Milford is based on chests with a history in that area of Connecticut. See Kirk (1967:nos. 49, 50).

---

## References

- Cummings, A. L.  
1971 Decorative painters and house painting at Massachusetts Bay, 1630–1725. In *American Painting to 1776: A Reappraisal*, ed. I. M. G. Quimby, 71–125. Charlottesville, Va.: University Press of Virginia.
- Fairbanks, J. L., and R. F. Trent  
1982 *New England Begins: The Seventeenth Century*. Vol. 3. Boston: Museum of Fine Arts.
- Fales, D. A., Jr.  
1972 *American Painted Furniture, 1660–1880*. New York: E. P. Dutton and Co.  
1976 *The Furniture of Historic Deerfield*. New York: E. P. Dutton and Co.
- Fodera, Peter  
1991 Treatment report for Fodera Fine Art Conservation, Ltd., 23 October, New York.



- 1992 Treatment report for Fodera Fine Art Conservation, Ltd., 27 July, New York.
- Graybeal, J. A., and P. M. Kenny**  
1987 The William Efner Wheelock collection at the East Hampton Historical Society. *Antiques* 132(2):328–39.
- Harley, R. D.**  
1982 *Artists' Pigments c. 1600–1835*. London: Butterworth Scientific.
- Kirk, J. T.**  
1967 *Connecticut Furniture, Seventeenth and Eighteenth Centuries*. Hartford, Conn.: Wadsworth Atheneum.
- Lockwood, L. V.**  
1926 *Colonial Furniture in America*. Vol. 1. New York: Charles Scribner's Sons.
- Peirce, D. C.**  
1976 American painted furniture at the Brooklyn Museum, 1675–1875. *Antiques* 110(6):1292–99.
- Safford, F. G.**  
1980 Seventeenth-century American furniture at The Metropolitan Museum of Art. *Apollo* 111(219):348–53.
- Schoelwer, S. P.**  
1989 Connecticut sunflower furniture: A familiar form reconsidered. *Yale University Art Gallery Bulletin* (spring):21–37.
- Schwartz, M. D.**  
1976 *American Furniture of the Colonial Period*. New York: Metropolitan Museum of Art.
- Stalker, John, and George Parker**  
1960 *A Treatise of Japaning and Varnishing*. 1688. Reprint, London: Alec Tiranti.
- Trent, R. F.**  
1994 A Channel Islands parallel for the early eighteenth-century Connecticut chests attributed to Charles Guillam. *Studies in the Decorative Arts* 2(1):75–91.
- Willoughby, M. H.**  
1994 From carved to painted: Chests of central and coastal Connecticut, c. 1675–1725. Master's thesis, University of Delaware.

# Chinese Motifs in the Baroque Art of Minas Gerais, Brazil

## Historical and Technical Aspects

Luiz A. C. Souza and Cristina Avila

**T**HE OCCUPATION of the former Brazilian captaincy of Minas Gerais (General Mines), in the southeast of Brazil (Fig. 1a, b), occurred as a direct result of the gold discoveries and subsequent gold mining in the region. The Portuguese colonization process began at the beginning of the eighteenth century, starting a new period in the history of Brazil and creating influences as far reaching as the Industrial Revolution in England (due to the trade agreements between Portugal and England). According to Eakin (1989:11):

Portugal covered its constant trade deficit with England with Brazilian gold, and Lisbon, in the end, became simply a way station for American bullion on its way north. Brazilian gold financed the commercial expansion of England in the early eighteenth century, and, in the last half of the century, its industrial expansion.

Due to the search for precious metals and gold mining, the occupation took hold in a very short time. The intense commercial activity and the demands of the new region gave rise to new and very active adminis-

Figure 1a, b

Map of Brazil (a), showing the position of the state of Minas Gerais and the gold mining region. Detail (b) of the gold mining region in Minas Gerais, indicated by a square in the map at left.

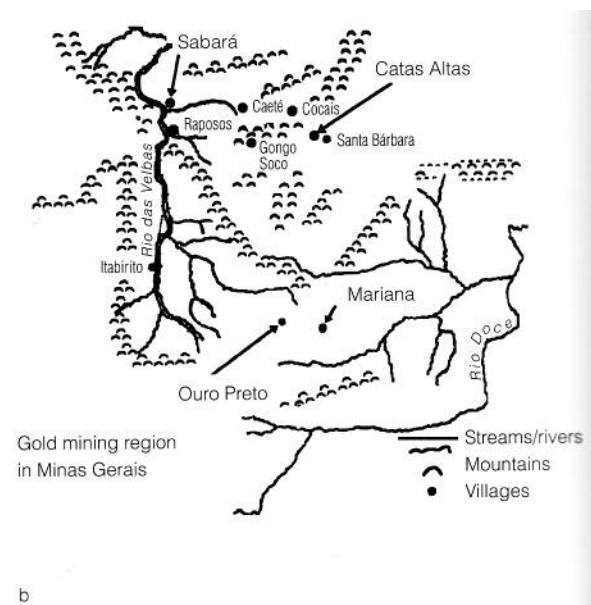

trative centers. The political climate in the region was of permanent conflict between the several social groups in Minas and the rigorous and oppressive Portuguese administration.

Even the Catholic religion adapted and became more devoted to its functions as an agent of social integration, virtually ignoring its missionary objectives. Religious practices were directed toward the external manifestations of the faith, as opposed to the understanding of the Catholic doctrine. As a result of these adaptations, most of the religious ceremonies were performed in a much more conspicuous manner, as evident in the processions and pilgrimages and in the decoration of the chapels and Baroque sculptures. Among other measures, the Portuguese efforts to control gold production and traffic resulted in the prohibition of Catholic religious orders, which were in Minas Gerais. This aspect of the town's history is particularly relevant when one observes the astonishing number of churches in small towns such as Ouro Preto (Black Gold)—which has twenty-three churches; and Sabará, which also has several. Each chapel was built by a different fraternity or brotherhood, and this resulted in intensive and competitive building and ornamentation of the numerous religious buildings in the mining regions.

---

## Evolution of the Religious Architecture

At the beginning of the Portuguese occupation of Minas Gerais, religious architecture was very primitive, and consisted only of small chapels with straw-covered roofs and walls built of wattle and daub. These buildings usually consisted of a nave as the main room, with a small altar for the saint of devotion.

In general, one of the biggest problems art historians now face in studying the art history of this region is the lack of documentation on the construction of the churches and on their interior decoration. However, detailed observations of the architectural features of the chapels has allowed scholars such as Avila (1984) to propose a chronology of their stylistic development. The proposed chronology is divided into three phases, following changes in building construction and style. The first phase is from 1700 to 1730, a period characterized by initial settlement and formation of the first villages. The Chapel of Our Lady of O (1717–20) (Fig. 2) and the Chapel of Our Lady of Soledade (1727), both in Sabará, are from this first phase. The second phase, from 1730 to 1755, is characterized by the introduction of regional materials, such as soapstone and quartzite, for structural and decorative uses. The third and last phase, from 1755 to 1785, is characterized by the widespread use of stone as a structural material in the religious and government buildings. Numerous churches were built during this phase, mainly because of the competition between several fraternities and brotherhoods.

---

## Interior Decoration of the Churches

A few chapels are decorated with Asian-style motifs, such as Chinese life scenes, pagodas, birds, elephants, rabbits, and so on. The traditional explanation for these Asian-influenced motifs in Minas Gerais is the Portuguese discovery of the maritime route to the Far East at the end of the fifteenth century, which certainly influenced the styles and techniques of Portuguese artists. On the origin of these motifs, the Brazilian author Andrade (1978) surmises that a Portuguese artisan may have learned the technique in China,

Figure 2

Exterior of the Chapel of Our Lady of O in Sabará, Minas Gerais, 1717–20. Notice the Chinese influence on the tiles at the corners on the upper roof. The interior of this church is particularly rich in panels with Asian painted and gilded motifs (Fig. 3).

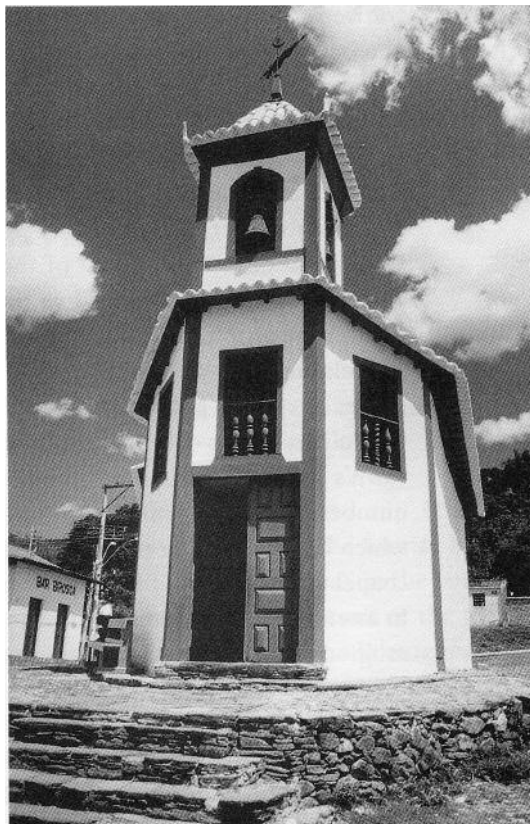

Figure 3

Detail of the interior decoration in the Chapel of Our Lady of O.

or even that a Chinese or Indian painter might have traveled to Minas Gerais and painted the motifs directly. Either explanation is historically plausible, as the Portuguese had established a maritime empire in the Far East beginning in the late fifteenth century from the base provided by their earlier exploration of the African coast. Portugal's colonies in the East Indies and Asia included Goa, Ceylon, Malacca, and Macao (Severy 1992).

Technical studies of the Asian-style motifs in Minas Gerais show, however, that the technique is perfectly in accordance with the European technique for chinoiserie, a practice that was already well known in parts of Europe after 1660 and that arrived in Portugal after 1720 (Smith 1962:117–18). The bookshelves at the library of the University of Coimbra, for example, are all painted in chinoiserie. The person who painted these decorations is known to be the Portuguese artist Manuel da Silva, who signed a contract in 1723 to do the paintings.

### Asian motifs in the interior decoration of the churches

Decorations with Asian motifs are present in Sabará (Figs. 2, 3), Mariana (Fig. 4), and Catas Altas (Fig. 5), which were very important mining villages during the eighteenth century. None of these cases have documentary evidence regarding the authorship of the motifs. In the church interiors, the motifs appear as bright figures over red or green backgrounds. In addition to the gilding, there is also extensive use of silver leaf, usually to represent human faces or the bodies of birds. The borders of the gilded or silvered parts are well defined with a black line, which is also sometimes used over the gilding to create contouring. In Minas Gerais, sil-

Figure 4

Cathedral of Sé, in Mariana, Minas Gerais. Detail of the decoration on the seats used by the priests. The faces and hands of the human figures in these panels are in silver leaf.

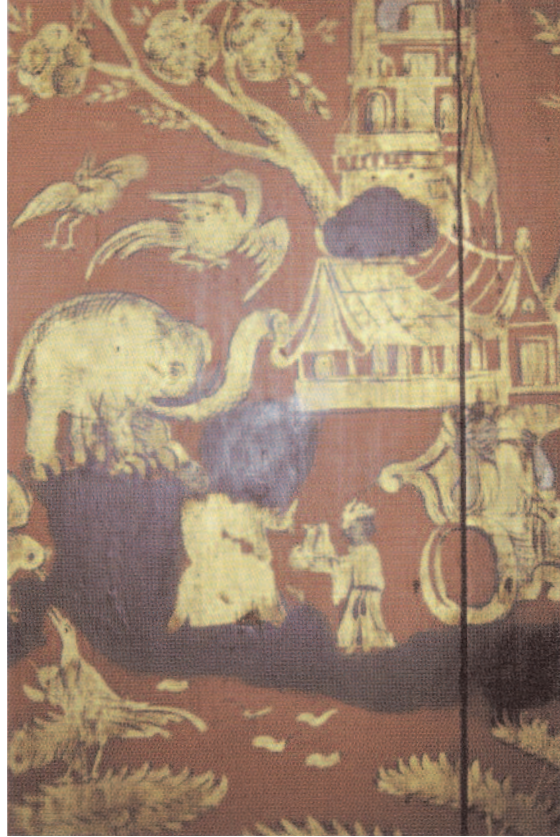

Figure 5

The Altar of Santo Antônio in the Mother Church of Our Lady of Conception, Catas Altas, Minas Gerais. Detail of the painted Asian motif.

ver leaf is not used as widely as gold leaf, the former being a subject that deserves more research, particularly the use of silver leaf on wood polychromed sculptures.

The following is a brief description of the churches and their locations.

#### Sabará

**The Mother Church of Our Lady of Conception.** Construction of this church started in 1701. The interior ornamentation is highly characteristic of the first phase of the Baroque style in Minas. Both gilding and carving are generously present throughout the interior. The design pattern is similar to that observed in the north of Portugal, the origin of most of the Portuguese artists who went to Minas Gerais.

**The Chapel of Our Lady of O.** This particularly small chapel is considered to be one of the most outstanding religious buildings of the colonial period in Minas Gerais (Fig. 2). The lavish interior ornamentation (Fig. 3) is characterized by painted and gilded Asian motifs, such as pagodas, Chinese scenes, and birds.

**The Chapel of Our Lady of Soledade.** Unfortunately, this chapel no longer exists, but remnants of the carved works and painted ceiling, which were saved by the municipality, are worth mentioning because of the singularity of the painted motifs (Fig. 6). The painted decorations of the ceiling are naive, and they clearly reflect an ingenuous attempt to produce Asian-style motifs. Together with the carved works from this chapel, these artistic expressions reflect popular art production in Minas Gerais that is sometimes found in small country chapels, most likely because of the lack of financial resources or of specialized artists and craftspeople.

Figure 6

Painted bird on a remnant of the ceiling from the Chapel of Our Lady of Soledade, Sabará, Minas Gerais. The simplified pattern of Asian style is characteristic of this little chapel.



### Mariana

**The Cathedral of Sé.** The ancient Mother Church of Our Lady of Ascension was the first Mother Church of Minas (1705), and in 1745 it became the Cathedral of Sé, the first seat of the archbishop of Minas Gerais. The altars and interior ornamentation of the church are of high quality, featuring polychromed sculptures and gilded altarpieces still in very good condition. The church has an organ dated 1751, which is decorated with Asian motifs similar to those already mentioned. In the main chapel, Asian motifs decorate the seats reserved for the priests (Fig. 4). These motifs include several Chinese-style scenes with birds, flowers, insects, and elephants. Of interest is the fact that the elephants' trunks are not anatomically correct, clear evidence that the painter had never actually seen an elephant.

### Catas Altas

**The Mother Church of Our Lady of Conception.** This church resembles a time capsule for the study of polychromy, gilding, and carving techniques in Minas Gerais. Construction of the church started around 1738 and continued for several years, but the interior decoration was never completely finished. The wood of the altars was polished only, ready to receive a ground. Some elements exist with only ground layer completed; the painting and gilding were never carried out. Yet other parts were completely finished, with painted, gilded, and silvered decoration. The interior decoration has never been restored—a key factor for the study of the original materials. A complete study of the materials and techniques used to decorate this church is the subject of the doctoral thesis of one of the authors (Souza), and some preliminary information from this study has already been published (Souza, Ramos, and Avila 1992). Chemical analysis was performed on samples from the Asian motifs on this church's altar devoted to Santo Antônio (the results are discussed in the following). These motifs are similar to those found in the other churches previously described; they are painted or gilded over a red or green background (Fig. 5).

### Other sources of Asian motifs

Finally, many of the figures of birds, flowers, and life scenes in the 1688 book published by Stalker and Parker closely resemble the figures in the

Asian motifs in Minas Gerais. Unfortunately, it is not possible to find lists of source books that may have been used as references by the Brazilian and Portuguese painters and artists working in Brazil, because after the end of the Inconfidência in Minas Gerais, Portugal ordered the destruction of some of the most important book collections. Even in the remaining documents, there is no reference to source books that may have been used by the artists working in Minas during the colonial period. Further research should be carried out in collections such as that at of the National Archives in Rio de Janeiro in an attempt to fill this gap in knowledge.

---

## Analytical Results

The analytical results displayed in Table 1 refer to samples taken from the Asian painted motifs on the Altar of Santo Antônio. The samples were analyzed through microscopy of the cross sections (Fig. 7a–f), after careful examination of the fragments under a binocular microscope. The samples for Fourier-transform infrared (FT-IR) spectrometry and polarized light microscopy (PLM) were selected and prepared from the original paint chips, after careful manipulation of the fragments with a small scalpel under the binocular microscope. Scanning electron microscopy coupled with energy-dispersive X-ray analysis (SEM-EDX) and fluorescence microscopy were employed after the cross sections were analyzed with reflected light under the microscope.

## Discussion of the results

The microscopic examination indicated that the structure of the materials, starting from the bottom layer, was as follows: *gesso grosso*, *gesso sottile*, bole, red layer, mordant, gold leaf or bronze powder, and a varnish. The stratigraphy of these painted motifs in Catas Altas is similar to that of the polychromed sculptures from the colonial period in Minas Gerais. The techniques for the ground layers and the bole are the same (Souza, Ramos, and Avila 1992). The bole was perhaps applied under the red layer to save on the more expensive vermilion, or it may be that bole was applied all over the white ground so some areas could be water gilded. Only some areas would then have the subsequent layers, as described here. There are two techniques that were noticed for the first time in polychromed sculpture in Minas: the use of oil-size gilding and the use of bronze powder as a decorative material. It should be emphasized that the term *bronze powder* is used to indicate the brass microleaves present in a sample (CA082); this is a terminology already in use in the conservation literature (Stodulski and Dorge 1991; Bernstein 1991).

### Varnish layer

The use of a varnish layer over the entire painted surface is a very important aspect of the technique because it gives a deep tonality to the red paint and reduces the reflective character of the gold leaf in oil gilding. It was not possible to positively identify the type of resin or mixture of resins used to make this varnish, but there are certain characteristics that should be mentioned. The FT-IR spectrum of a fragment of the varnish is very similar to the spectrum of a particular Brazilian resin that is extracted from trees of the genus *Hymenaea*. In Brazil, the resin is sometimes called *Resina do Jatobá*, but it also has other names throughout the country. Some of the European naturalists who visited Brazil during the beginning of the

Table 1 Summary of the results obtained from analysis of painted Asian-style motifs

	Sample CA083 Red surface covered with varnish	Sample CA084 Matte gilded decorations	Sample CA082 Brown areas in the painting
Microscopy		7 yellowish top varnish	7 yellowish top varnish
		6 gold leaf, covered with black pigmented layer at the borders	6 green-brown with dispersed metallic microleaves (bronze powder)
	5 yellowish top varnish	5 mordant	5 mordant
	4 red layer	4 red layer	4 red layer
	3 bole	3 bole	3 bole
	2 gesso sottile	2 gesso sottile	2 gesso sottile
	1 gesso grosso	1 gesso grosso	1 gesso grosso
PLM		7 pure transparent organic layer, isotropic, RI<1.66	7 pure transparent organic layer, isotropic, RI<1.66
		6 not analyzed	6 transparent greenish isotropic medium, RI<1.66; copper resinate, partially discolored (turned brown)
	5 pure transparent organic layer, isotropic, RI<1.66	5 not analyzed	5 not analyzed
	4 vermilion (very small particles) and red lead	4 vermilion (very small particles) and red lead	4 vermilion (very small particles) and red lead
	3 iron oxides + graphite	3 iron oxides + graphite	3 iron oxides + graphite
	2 gypsum (small particles, very well crystallized)	2 gypsum (small particles, very well crystallized)	2 gypsum (small particles, very well crystallized)
	1 gypsum (particles of heterogeneous sizes)	1 gypsum (particles of heterogeneous sizes)	1 gypsum (particles of heterogeneous sizes)
FM	5 bright yellowish green fluorescence	7 bright yellowish green fluorescence	7 bright yellowish green fluorescence
FT-IR	5 spectrum characteristic of terpenic resins (confirms gypsum in both layers 1 and 2)	7 spectrum characteristic of terpenic resins (confirms gypsum in both layers 1 and 2)	7 spectrum characteristic of terpenic resins (confirms gypsum in both layers 1 and 2)
SEM-EDX	not performed	7 organic, no metallic elements present	7 organic, no metallic elements present
			6 metallic microleaves: brass (Cu with traces of Zn)
			5 clay (Si, Al, Fe), plus lead-containing particles
		1, 2 shows clear differentiation between gessos in layers 1 and 2	

Numbering refers to the sequence of layers, from bottom to top.

PLM = polarized light microscopy

FM = fluorescence microscopy

Samples were taken from the Altar of Santo Antônio, Mother Church of Our Lady of Conception, Catas Altas.

#### Figure 7a–f

Photomicrographs of the cross sections of samples CA084 and CA082 (described in Table 1), examined under the microscope (a, b, c) and SEM (e, f). Cross section (a) of sample CA084, viewed at  $\times 128$  magnification with reflected light; same cross section (b) viewed under the SEM (notice the irregular gold leaf over the mordant layer); cross section (c) of sample CA082, viewed at  $\times 128$  magnification; detail (d) of CA082, showing the metallic microleaves; SEM detail (e) of the mordant layer and the bronze powder layer; and mapping (f) of Pb distribution on CA084 (mapped area displayed in “e”), showing the presence of lead on the mordant layer.



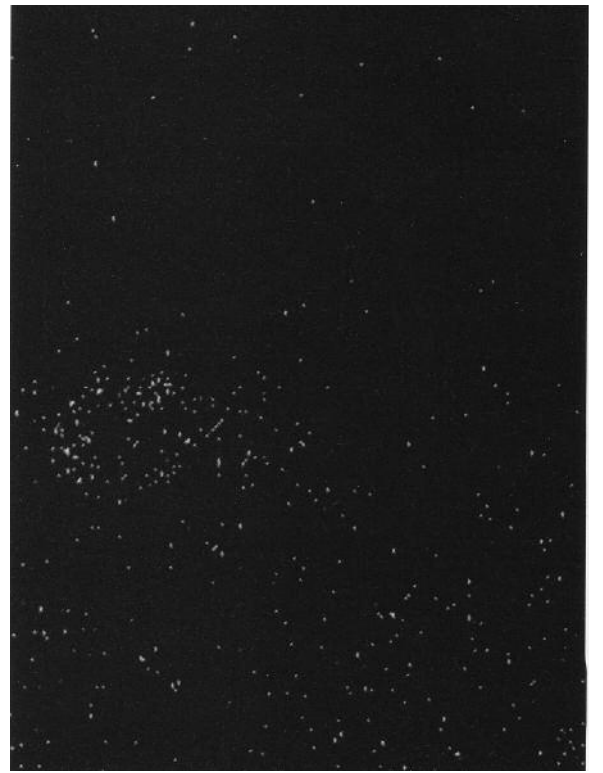
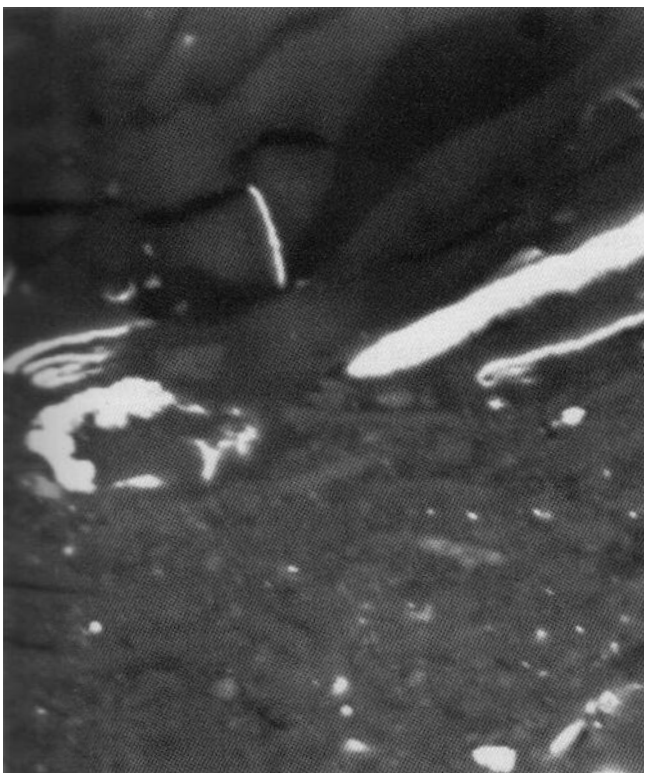
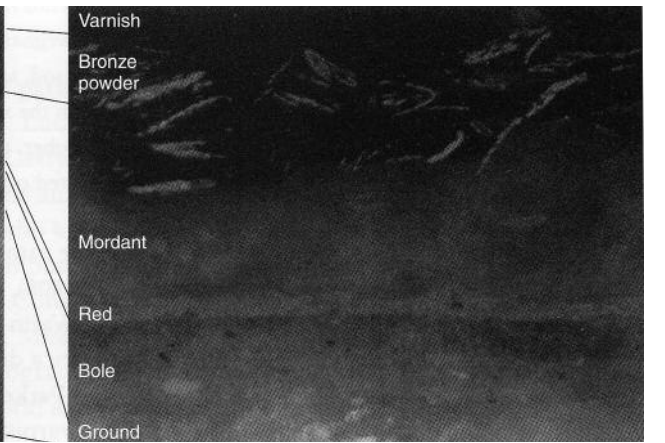
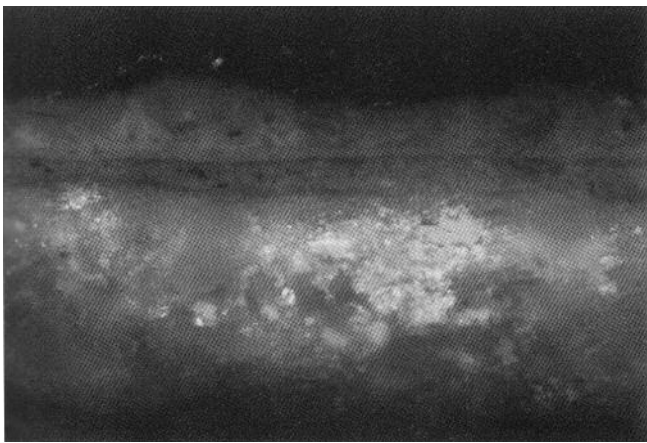
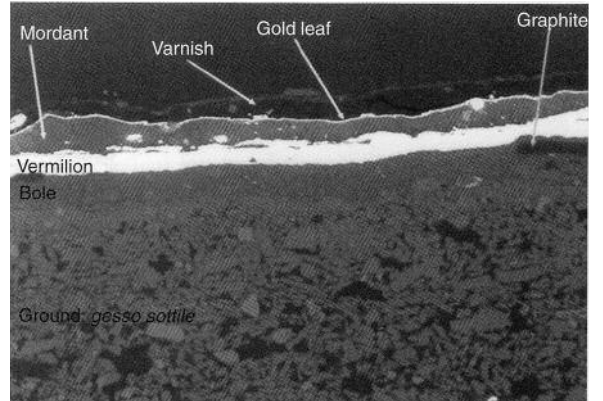
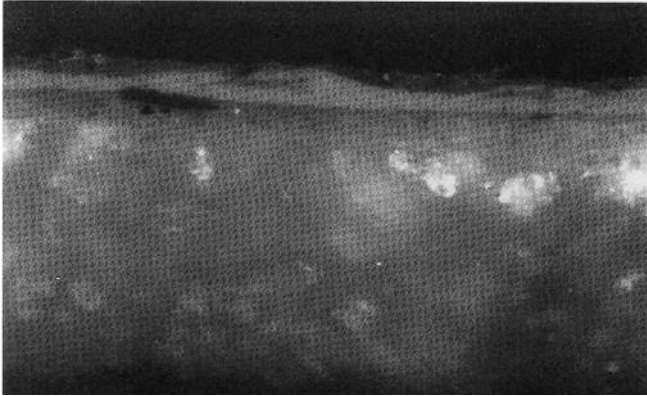

nineteenth century have already provided a description of the resin (Spix and Martius 1981:184; de Saint-Hilaire 1975:177). It is also mentioned by Nieuhoff (1813), a Dutch traveler who was in the north of Brazil during the Dutch occupation of that part of the country in the sixteenth century. According to Spix and Martius (1981:184):

In the forests we observed many of those trees from which comes the resin *anime* (*Hymenaea courbario* L.). Here they call it *jatoba* or *jataí*. Between the shell and the wood of this tree, which is similar to our elm, there are relatively few spaces filled with liquid resin; the major portion of resin comes from the axial roots of the tree, when injured, which generally happens when the tree is cut. Behind the old trees it is possible to find some round balls, of clear-yellow, weighing about six to eight pounds, formed by the continuous dripping of the liquid resin. The purity and color of this substance depends mostly on the kind of soil where the balls are formed, because it impregnates the resin with certain soluble substances which don't exist in a dry soil, argillous or sandy. The finest resin is, however, the one which comes from the shell, mostly at the end of the dry season, during September and October; the indigenous people collect the resin by drops, which are then melted over the fire.

The same resin is referred to as *anima* by Watin in his treatise on varnishes (1808). He mentions the *Hymenaea* trees from South America as its source. Watin also affirms that this resin was imported to Europe from South America during the eighteenth century. It is surprising to find that Stalker and Parker (1960:10) also quote this *anima* resin in one of their recipes for varnishes, but without mentioning its source or other common or scientific name. João Manso Pereira, a Brazilian chemist who lived in Rio de Janeiro (ca. 1750–1820) was famous for being able to prepare porcelain, varnish, and lacquering as perfect as the best from India (Santos 1942:490). The main ingredient of the varnish is cited as the resin from *Jatobá* trees, dissolved in very strong *aguardente*—an alcoholic drink popular in Brazil, produced by the fermentation and distillation of sugar-cane juice. To date, there are insufficient analytical results to prove that the *resina do jatobá* was actually used in the formulation of the varnish for the Asian motifs in Catas Altas, but the information collected thus far may be helpful for future researchers addressing this subject.

#### **Mordant layer**

Analysis by SEM-EDX clearly shows that there are lead-containing particles in the mordant layer, together with clay and iron oxides; this is a traditional technique for preparing oil size for gilding.

#### **Bronze powder**

The SEM-EDX analysis of the resinous medium surrounding the metallic leaves shows the presence of copper in the material, which leads to the conclusion—confirmed by the PLM observations—that there is copper resinate in the resinous medium in which the metallic plates are dispersed. It is not clear, however, whether this copper resinate was originally applied to the surface or if it is there as a degradation product of the brass particles in contact with the resin. The brown superficial aspect of these areas in the painting is certainly due to the discoloration of the copper resinate,

as can be observed through PLM analysis of particles taken from the greenish layer.

---

## Conclusion

Contrary to the general art historical approach for the authorship of the Asian painted motifs in Minas Gerais, the authors conclude that the artists who created these decorations were either Portuguese or Brazilian painters who used the European technique for imitating the Chinese style. These motifs in Minas Gerais can, therefore, be called *chinoiserie* because they are in perfect accordance with the definition of this term (Impey 1977:9) as referring to a European imitation of the Asian style.

The varnish used as a finishing layer on the *chinoiserie* in Minas Gerais may contain the Brazilian resin previously referred to as *resina do jatobá*, also known as *anima*.

---

## Acknowledgments

This research was partially funded by the CNPq—the Brazilian National Research Council. Luiz Souza undertook the research during a two-year fellowship at the Getty Conservation Institute (then in Marina del Rey, California), and the authors are grateful to Miguel Angel Corzo, director of the Institute, who kindly provided support for Souza's attendance at the Painted Wood Symposium. Particular thanks are due to the following: the staff of the Getty Conservation Institute Scientific Program (Dusan Stulik, Michael Schilling, Michele Derrick, Eric Doehne, and Arie Wallert); Valerie Dorge, program chair of the Painted Wood Symposium, for her interest in our work; and Brian Considine and Gordon Hanlon at the J. Paul Getty Museum, for the very fruitful discussions on the subject of this article. We are grateful to Adriano Ramos of the Grupo Oficina de Restauro in Brazil for his invaluable discussions regarding the subject of *chinoiserie* in Minas Gerais, and to the Brazilian Institute of Cultural Properties for allowing us to take samples in Catas Altas.

---

## References

- Andrade, R. M. F.  
1978 A pintura colonial em Minas Gerais. *Revista do Patrimônio Histórico e Artístico Nacional* 18:11–47.
- Avila, A.  
1984 *Iniciação ao barroco mineiro*. São Paulo: Nobel.
- Bernstein, J.  
1991 Microscopy-based characterization of gilded decoration on furniture. In *Seventeenth Annual Conservation Training Programs Conference*, 138–150. New York: Conservation Center, Institute of Fine Arts.
- de Saint-Hilaire, A.  
1975 *Viagem pelas províncias do Rio de Janeiro e Minas Gerais*. Trans. Vivaldi Moreira. São Paulo: University de São Paulo; Belo Horizonte: Itatiaia.
- Eakin, M. C.  
1989 *British Enterprise in Brazil—The St. John d'el Rey Mining Company and the Morro Velho Gold Mine, 1830–1960*. Durham, N.C., and London: Duke University Press.

- Impey, O.**  
1977 *Chinoiserie—The Impact of Oriental Styles in Western Art and Decoration*. New York: Charles Scribner's Sons.
- Nieuhoff, J.**  
1813 Voyages and travels into Brazil with a particular account of all the remarkable passages that happened during the author's stay of nine years in Brazil. In *A General Collection of the Best and Most Interesting Voyages and Travels in All Parts of the World*. Vol. 14, ed. J. Pinkerton, 697–877. London: Longman.
- Santos, F. M. dos**  
1942 Artistas do Rio de Janeiro colonial. In *Anais do Terceiro Congresso de História Nacional*. Vol. 7, 489–94. Rio de Janeiro: Instituto Histórico e Geográfico Brasileiro.
- Severy, M.**  
1992 Portugal's sea road to the East. *National Geographic* 182(5):56–92.
- Smith, R.**  
1962 *A Talha em Portugal*. Lisbon: Livros Horizonte.
- Souza, L. A. C., A. R. Ramos, and C. Avila**  
1992 The Matriz of Catas Altas, Minas Gerais, Brazil: Techniques, materials and style. In *Conservation of the Iberian and Latin American Cultural Heritage*, ed. H. M. W. Hodges, John S. Mills, and Perry Smith, 154–57. London: International Institute for Conservation of Historic and Artistic Works.
- Spix, J. B. von, and C. F. P. von Martius**  
1981 *Viagem pelo Brasil 1817–1820*. Vol. 1, trans. Lucia Furquim Lehmeyer, rev. B. F. R. Galvão and B. de G. E. Winkler. São Paulo: University de São Paulo; Belo Horizonte: Itatiaia.
- Stalker, J., and G. Parker**  
1960 *A Treatise of Japaning and Varnishing*. 1688. Reprint, London: Alec Tiranti.
- Stodulski, L. P., and V. Dorge**  
1991 Analysis of materials from a late 15th–early 16th-century polychromed wood sculpture. In *Materials Issues in Art and Archaeology II*, ed. Pamela B. Vandiver, James Druzik, and George Segen Wheeler, 151–75. Materials Research Society Symposium Proceedings, vol. 185. Pittsburgh: Materials Research Society.
- Watin, M.**  
1808 *L'art du peintre, doreur, vernisseur, et du fabricant de couleurs*. 6th ed. Paris: Belin.

# A Short Primer on the White-Painted Furnishings of Eighteenth-Century Philadelphia

*Chris A. Shelton*

WHILE WHITE PAINT has been a ubiquitous decoration for exterior and interior architecture, it was also used to decorate some of the highest style furnishings of the eighteenth century. White-painted looking-glass frames, carved wall brackets, and furniture were produced in Philadelphia during the eighteenth century—beginning the decade before the Revolution—but they are quite rare in America’s decorative arts collections.<sup>1</sup> At that time, the wealthy patrons of Philadelphia (perhaps the most cosmopolitan colonial city) sought both imported and locally produced carved furnishings and decoration in the latest London fashion. London craftsmen, like their counterparts in other urban centers of Europe, were inspired by the asymmetrical, carved, painted, and gilded decoration of the French Rococo style. This manner of decoration had been popular in the 1750s and 1760s among English cabinetmakers, who produced frames and furniture in this style (Gloag 1968).

White-painted decoration continued to be fashionable in Philadelphia even as the city became the capital of the new republic, and the city’s patrons and craftsmen embraced the new Classical taste of London and Paris. The simplicity of Classical designs, many of which were based on motifs from the rediscovery of the ancient Roman cities of Herculaneum and Pompeii, made a compelling new fashion, in direct contrast to the exuberance of curvilinear Rococo design. For example, English architect Robert Adam’s frescolike palette with white and gold decoration and symmetrical foliage swags, revived Classicism in English interiors and became synonymous with the English national taste during the last third of the eighteenth century (Fowles and Cornforth 1979:26–27, 32).

Unfortunately, the few surviving white-painted surfaces of furnishings attributed to Philadelphia have been mistakenly gilded or otherwise obliterated and restored with surfaces that do not visually represent this subtle type of decoration. Recent investigations of several of these furnishings have provided an opportunity to reexamine the materials and techniques of this often misunderstood painted decoration. Treatises from this period document techniques for white-painted decoration and can provide insight for reinterpreting these surfaces. These treatises, combined with accurate identification of the constituent paint materials, make it possible to better understand and preserve white-painted objects.

---

## Review of Period Literature

Treatises on painting produced in London and Paris have provided a wealth of information about the materials, techniques, and aesthetics of eighteenth-century workmanship. While many important accounts dealing with gilding and japanning were produced throughout the seventeenth and eighteenth centuries, two major works stand out as resources for understanding period paint technology, and more specifically, white-painted decoration on wood.

The first is the 1773 guidebook, *L'art du peintre, doreur, vernisseur* by Jean Félix Watin (reprinted in 1977). A master gilder who graduated from the Académie de Saint Luc, Watin set up shop in the Bonne-Nouvelle district of Paris, where he became a dealer in prints and also sold colors, gilding supplies, and varnish (Pallot 1989:39). His treatise is one of the most exhaustive examinations of gilding in the eighteenth century and provides an excellent summary of painting practices. In 1803, the English cabinetmaker Thomas Sheraton produced the second important guidebook, *Thomas Sheraton's Cabinet Dictionary* (Sheraton 1970b). In addition to illustrating furnishings and advising on their use and placement, this treatise includes an extensive supplement regarding geometry, perspective, and all types of painting.

Paint is a complex material made of a film-forming binder (such as oils, resins, gums, or hide glue) and a finely divided colorant, the pigment. As Sheraton (1970b:415) observed in 1803, "there are various methods for priming, coating, and giving the finishing lay of plain surfaces . . . in point of durability, cheapness, facility and beauty . . . whether in oil, varnish or water colors (distemper)." The binder chosen to formulate a paint determines many of its working properties and its subsequent durability. For instance, white paints made with drying oils, such as linseed oil, have often been used for exterior architecture because they form durable and largely water-resistant protection for the wood. In interior settings, where weathering is minimal, paints formulated with various animal-hide glues—known today as size or distemper paints—were used. They had the advantage of being fast-drying and not having the turpentine fumes associated with oil-based paints.

Much of the appearance of a paint is determined by the choice of pigment. In addition to color and texture, consideration must be given to the differences in optical and physical properties of pigments. Light is refracted (that is, bent) as it passes through the binder, and it is further refracted, reflected, or transmitted through the pigment particles. These interactions lend varying degrees of opacity to paints. For instance, chalk (a common white pigment) and various drying oils have very similar refractive qualities that result in a very translucent white oil paint. By contrast, lead white, the highly refractive pigment created by grinding the flakes of corrosion product scraped from lead sheet, produces a very opaque white oil paint.<sup>2</sup>

The steps involved in producing a finely painted wood surface are simple. The wood is first sealed with oil or a coat of hide glue and then is coated with a suitable primer to fill the pores and produce a uniform surface. One or two coats of the desired paint are then applied. A more saturated, glossy surface is created by applying a varnish over the paint. Although this practice was used for oil-bound paints, both Sheraton and Watin suggest it is particularly useful for distemper paints, since it provides a layer of protection for the water-sensitive distemper.

White-painted surfaces with a range of surface qualities could be created using just a few pigments, glue or oil, and varnish, depending on how the paint was formulated and layered. Indeed, the character of this painted surface is one of the most important considerations for white-painted decoration.

Matte white surfaces were also popular in the eighteenth century. Watin (1977:83) explains that such a surface could be created using hide glue and a dense lead white pigment that came to be known as “the King’s white” because the French king’s apartments were painted this matte white color. To prepare the surface, the wood is first sealed with glue size and then primed with gesso (a mixture of a strong glue size and chalk). One or two coats of the paint made with strong glue size and lead white pigment would produce the desired delicate matte appearance. Watin (1977:83) notes that “this white, according to the workers, is friendly to gold; that is to say the gold shines by its beautiful matte quality.” Unfortunately, it was easily spoiled by the pigment’s darkening or being burnished by wear.

Sheraton, in discussing “the fine dead whites sometimes used in domestic painting,” details a similar matte white surface produced with oil paints. For this technique, however, the wood was primed not with gesso but with glue size and lead white pigment. This lead-based primer was then coated with a leanly bound lead white oil paint. Sheraton (1970b:418) explains that “the deadness of the white will partly depend upon the coats of size given, which, if substantial, partly absorbs the oil colour, and renders it dead.” Because it remained unvarnished, this oil-bound, matte white surface would present many of the same problems of discoloring and uneven wear as the glue-bound technique.

A more saturated or glossy white surface is created by applying a varnish. Distemper-painted surfaces were also frequently varnished to increase their durability. Varnished white-painted surfaces are described by both authors as a refined surface for paneling and decoration. Chipolin, a varnished distemper paint, is described by Watin (1977:76) and given very high regard:

Nothing is so magnificent for a drawing room or a suite of rooms as a superb paneling painted in this manner. One can offer the ostentatious richer, more sumptuous embellishments, but one cannot present to the wise a more noble, more economical, and durable decoration. This paint has the brilliance and freshness of porcelain.

The wood is first sealed with a glue size containing a fungicide, usually garlic and leaf extracts; then the surface is primed with gesso made from strong parchment size and chalk or white clay. The smoothed and primed surface is painted with strong glue size mixed with lead white pigment and clay (with a small amount of indigo or black to counter any yellowish color in the mixture). The painted surface is then sealed with a final wash of glue size and given several coats of clear alcohol-soluble varnish (Watin 1977:79–83).

Although there are many other possible permutations, these three techniques for white-painted decoration reveal the sophistication of the eighteenth-century craftsman. Not only were oil and distemper paints—often containing lead white—used to create these subtle surfaces, but both matte and porcelainlike surfaces were desirable.

---

## White-Painted Decoration from Philadelphia

Three furnishings made in Philadelphia in the eighteenth century have been the subject of recent examination to identify the binders and pigments in the original white-painted decoration. Two powerful techniques—fluorescence microscopy with reactive fluorescent dyes, and scanning electron microscopy (SEM) with energy dispersive X-ray analysis (EDX)—were performed on small cross-sectional samples of painted decoration. In addition to identifying the organic and inorganic constituents of paints, these techniques provide direct observation of the thickness, density, appearance, and condition of each layer. An added benefit is that the same sample can be used for both techniques.

Fluorescence microscopy of cross-sectional samples is one of the most useful methods for examining painted decoration. It was used in this study to chemically characterize the different binders through observation of their fluorescence and reactivity with various fluorescent dyes to mark layers with specific chemical structures.<sup>3</sup> Scanning electron microscopy was used both to image layers and particles according to the mean atomic weight using their backscattered electrons and to analyze the X-ray emissions of individual pigment particles to identify their elemental composition.<sup>4</sup> The results of these examinations compare favorably with the materials and methods of the period identified by Watin and Sheraton.

Many English craftsmen experienced in the Rococo style emigrated to Philadelphia in the 1760s. Some brought the printed Rococo designs of English carvers and cabinetmakers like Thomas Johnson and Thomas Chippendale (Hecksher and Bowman 1992:1–15). These craftsmen produced perhaps the most robust Rococo carving in the colonies, as well as some of the only locally produced, white-painted furnishings. The two earliest objects examined (Figs. 1, 2) are the work of James Reynolds. These objects are important not only because they are attributed to a specific maker, but also because they represent two different contemporary aesthetics for purely white-painted decoration.

Reynolds arrived in Philadelphia in 1766 and soon advertised himself as a “CARVER and Gilder, Just arrived from London . . . UNDERTAKES to execute all the various branches of carving and gilding in the newest . . . taste” (Beckerdite 1984). By the next year, he also undertook paperhanging, and manufactured papier-mâché borders, ceiling ornaments, and brackets. He also imported looking glasses, and marketed materials such as English glue, gold leaf, bronze, quicksilver, tinfoil and white and brown varnish (Prime 1969:225).

Frames and looking glasses were an integral part of the fashionable decoration of the time. Reynolds advertised undertaking “all kinds of frames in carved gold, carved and white, or carved Mahogany Frames” (Garvan 1976:95). John Cadwalader had commissioned four looking glasses from Reynolds, and in 1771 was billed by Reynolds for a fifth looking glass “in a carv’d white frame,” which is now owned by Winterthur Museum (Fig. 1) (Duerbeck 1994).

Close inspection of this looking-glass frame reveals that it has been restored with a partially gilded surface that obscures the delicate veining in the carving. Because of its altered surface, this looking glass has frequently been mistaken for a partly gilded looking glass ordered by Cadwalader in 1770.

Several cross-sectional samples were taken from the frame and analyzed using both fluorescence microscopy and SEM to identify the constituent pigments. The samples confirmed that the surfaces have had a



Figure 1

Carved pine (*Pinus*), white-painted looking glass with gilded highlights, 1770–71. Attributed to Philadelphia carver-gilder James Reynolds.



number of later restorations over the original white-painted surface. The decoration was developed in a manner similar to Sheraton's technique for a "dead white" painted surface using an oil-bound paint. The carved frame had been primed with a coarse lead white pigment in a binder that was characterized microscopically as a proteinaceous glue. The entire surface was then painted with a finely ground lead white pigment in an oil binder; no gilding or varnish was evident on the original surfaces (Duerbeck 1994).

James Reynolds is also believed to be the maker of the only attributable carved wall bracket made in Philadelphia (Fig. 2) (Hecksher and Bowman 1992:190). This object has been examined and conserved and provides an important counterpoint to the Reynolds looking glass. Before conservation, some interpreted the dark brown surface as an attempt to paint the pine surface to imitate mahogany. Samples of the surface decoration, taken to develop a conservation plan, revealed a much different original appearance beneath later restorations (Podmaniczky 1994). Observations made under the microscope indicate that, unlike the looking-glass frame, there is an original varnish coating that would have produced a porcelainlike appearance very different from the dead white of the looking glass. Therefore, it is probable that Reynolds produced both matte and glossy white-painted surfaces, depending on the fashion and taste of his patron.



Figure 2

Carved pine, white-painted wall bracket, 1765–75. Attributed to Philadelphia carver-gilder James Reynolds.

White-painted decoration has often been used in concert with gilding, particularly in the later Rococo and Neoclassical decorations. Gilding did find favor in American architectural interiors of wealthy



Figure 3  
Neoclassical ash (*Fraxinus* spp.) armchair, with applied composition ornament and white-painted and gilded decoration, 1790–1800, from Philadelphia. (The Bayou Bend Collection, Museum of Fine Arts, Houston. Museum purchase with funds provided by the Theta Charity Antiques Show.)

patrons such as John Cadwalader. Another English-trained carver-gilder, Hercules Courtney, charged Cadwalader for laying twenty-seven books of gold onto a carved cornice, and glazier Anthony de Normandie charged for “laying gold on 786 feet Paper Mache” (Wainwright 1964:29, 46). However, it was only with the fashion of Neoclassical style furniture in an English or French style that gilded furniture became popular in Philadelphia. The sale of the furnishings of Governor Penn’s town house in 1787 is an early documented example of gilded Neoclassical furnishings; it included “two settees in burnished gold . . . 12 chair and a fire skreen in burnished gold to suit ditto” (Kimball 1931:378).

The inspired Neoclassical designs for furniture that were collected and published by Thomas Sheraton incorporated many of the same motifs as found in the interiors created by architect Robert Adam, including gold and white decoration. Sheraton’s designs spread the London style of Neoclassicism throughout England and to America (Cole and Montgomery 1970:preface). At least one set of armchairs based on Sheraton’s gold and white “drawing room” chairs was produced locally in Philadelphia in the 1790s. This set of Neoclassical armchairs with white-painted and water-gilded decoration has been the focus of extensive research and conservation in the past few years (Fig. 3). Seven of these chairs are known today.<sup>5</sup>

Their form corresponds closely with the designs for drawing-room chairs illustrated by Thomas Sheraton in his 1793 *Cabinet Maker’s and Upholsterer’s Drawingbook* (Sheraton 1970a:367). They are also decorated as Sheraton suggested: “These [drawing room] chairs are finished in white and gold, or the ornaments may be japanned; but the French finish them in mahogany, with gilt moldings” (Sheraton 1970b:387). These chairs also are important because they have molded composition ornament instead of carving for decoration on the seat rails, arms, and crests, and they retain their original upholstery foundations.

Visual inspection reveals that the chairs have been heavily restored with both oil gilding and bronze-powder paint, as well as different types of white paint on several of them. The original surface treatment of these chairs was much more refined. The ash chair frames first were prepared with several layers of a traditional chalk and glue gesso, which filled the pores of the wood and provided a uniform surface for the gilding. Areas of the chairs, including all raised composition ornament and the molded edges of the chair rails, were then coated with red bole in glue and were water gilded.

The next step was application of a denser white paint to the background. Watin (1977:83) explained this process:

Once the work is finished on the areas to be gilded, the background is painted. . . . When painting close to the gilded areas the color is applied with small very fine brushes, cutting off very cleanly any gold that seems to be running.

On the Philadelphia chairs, a thin coat of lead white distemper paint covered the “running” red bole and gold that lapped onto white portions of the scheme in the background of the seat rails and on the turnings. Surprisingly, samples from many sites on the chairs confirm that the gesso primer served as the final white decoration layer in other areas (Figs. 4–6).

*Figure 4*

Backscatter SEM image of a cross section of white-painted decoration from the armchair shown in Figure 3. Elements with higher atomic weight appear lighter. The brightest layer contains lead white pigment, while the darkest contains calcium carbonate.

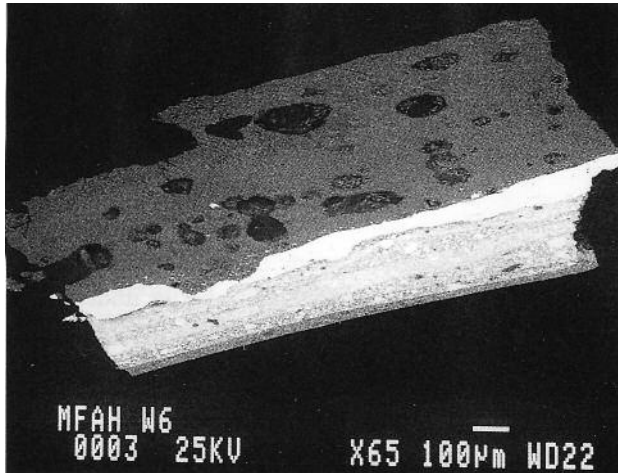
*Figure 5*

Cross section of white-painted decoration from the armchair shown in Figure 3. Visible light illumination, and  $\times 100$  magnification. When the adjacent surfaces were gilded, a thin layer of red bole covered the white ground. A thin layer of dense lead white paint was used by the artisan to cover this excess bole. Two later restoration layers are also visible.

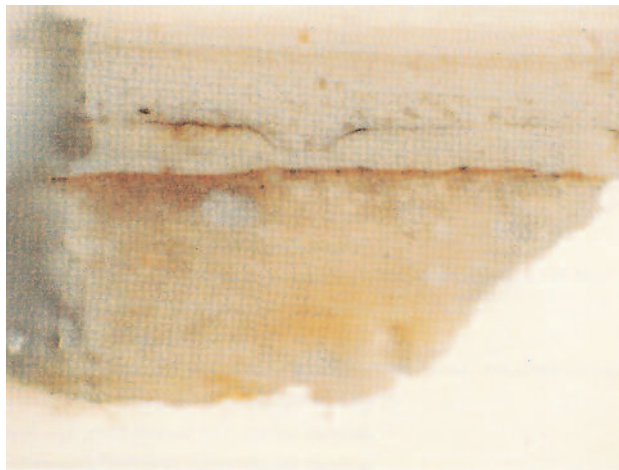
*Figure 6*

Fluorescence image of the same cross section shown in Figure 5, illuminated with ultraviolet light,  $\times 100$  magnification. Note the similarity in the fluorescence of the organic binders between the ground and the paint used to cover the excess bole. These binders were positively characterized with reactive fluorescent stains used to identify proteins, such as hide glue.

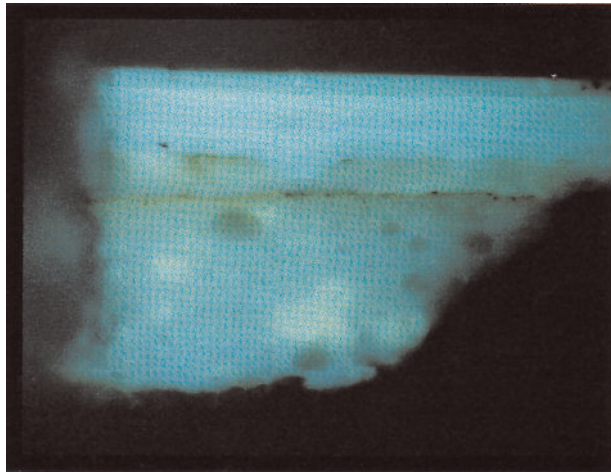

The gilded and painted surfaces of these chairs were varnished to produce a uniform, porcelainlike appearance and to provide a necessary layer of protection. Although the chalk ground represents an unusual choice for primary white decoration, the use of an opaque lead white distemper paint to cut off the gold and a clear, unifying, protective varnish are indicative of a high degree of sophistication on the part of the craftsmen.

---

## Conclusion

White-painted decoration was widely used in Europe in the eighteenth century, both in the French inspired Rococo style and later in the Neoclassical style. The treatises of Watin and Sheraton suggest that both oil and distemper paints were acceptable for interior white-painted surfaces. Furthermore, by utilizing varnish coatings, surfaces ranging from matte to porcelainlike could be made. Thorough examinations of white-painted surfaces with cross-sectional microscopy and scanning electron microscopy can allow for characterization of binders and pigments, making it possible to better understand the material and cultural context of these eighteenth-century objects and the original details of their primary surfaces, so that their conservation may be directed.

---

## Notes

- 1 For a more complete discussion of the Rococo style, see Fiske 1943 and Pallot 1989.
- 2 The refractive index ( $n$ ) of a medium is the ratio of the sines of the angles of incidence and refraction of a ray of light passing from one medium (usually air) into the given medium. For linseed oil, the refractive index is  $n=1.47$ . Chalk has a refractive index of  $n=1.51$ —very close to linseed oil—while lead white has a refractive index of  $n=1.94$ .
- 3 Small samples of the decoration were cast in Bioplastic brand polyester-polystyrene resin. Each sample was ground perpendicular to the outer surface and polished with Stoddard's solvent on 400 and 600 grit wet/dry abrasive papers and with 1 micron alumina powder. Samples were viewed using a Nikon Labophot-pol microscope fitted with fiber-optic lamps and an episcopic-fluorescence attachment, which allows the sample to be exposed to normal white light and ultraviolet (UV) light for examination of the fluorescent characteristics of the sample. The UV light is passed through a series of filters, either (1) in a violet cube block (Nikon V-2B) with the following specifications: excitation, 380–425; dichroic mirror, 430; barrier filter, 450 (Nm); or (2) in a blue cube block (Nikon B-2A) with the following specifications: excitation, 450–490; dichroic mirror, 510; barrier filter, 520. Fluorochrome dyes were used to microchemically characterize specific types of artists' materials. Three fluorescent dyes were applied to each sample and observed under UV illumination: triphenyltetrazolium chloride (TTC) in a 4% solution in ethanol to react with carbohydrates; fluorescein isothiocyanate (FITC) in a 0.2% solution of acetone to react with free amino groups commonly found in proteins and in some modern emulsion paints; Rhodamine B (RHOB) to mark lipid structures, such as in drying oils.
- 4 Scanning electron microscopy was performed at Exxon Research and Production Facility, Houston, Texas, by Bob Klimentidis. The samples were coated with carbon to provide a conductive surface.
- 5 In addition to the armchair owned by the Bayou Bend Collection of the Museum of Fine Arts, Houston, six others have been located. Two of the armchairs are owned by the H. F. DuPont Winterthur Museum; see Montgomery (1966:142–44). Another pair is privately owned by Joseph and June Hennage. One chair is owned by George and Linda Kaufman; see Flanigan (1986:130–31). The seventh chair is in the collection of the Yale University Art Gallery.

---

## References

- Beckerdite, Luke  
1984 Philadelphia carving shops part 1: James Reynolds. *Antiques* 125(5):1120–33.
- Cole, Wilford P., and Charles Montgomery, eds.  
1970 Preface to *Thomas Sheraton's Cabinet Dictionary*, by Thomas Sheraton. New York: Praeger Publishers.
- Duerbeck, Deborah  
1994 Report on object no. 52.261. Winterthur Museum, 31 January.
- Flanigan, J. Michael  
1986 *American Furniture from the Kaufman Collection*. Washington, D.C.: National Gallery of Art.

- Fowles, John, and John Cornforth**  
1979 *English Decoration in the 18th Century*. London: Barrie and Jenkins.
- Garvan, Beatrice**  
1976 *Three Centuries of American Art*. Philadelphia: Philadelphia Museum of Art.
- Gloag, J.**  
1968 English furniture in the French taste, part 1. *Antiques* 64(3):355–62.
- Hecksher, M., and L. Bowman**  
1992 *American Rococo*. New York: Metropolitan Museum of Art.
- Kimball, Fiske**  
1943 *The Creation of the Rococo*. Philadelphia: Philadelphia Museum of Art.
- Kimball, M. G.**  
1931 The furnishings of Governor Penn's town house. *Antiques* 19(6):378.
- Montgomery, Charles F.**  
1966 *American Furniture: The Federal Period*. New York: Viking Press.
- Pallot, G. B.**  
1989 *The Art of the Chair in Eighteenth Century France*. Paris: ACR-Gismondi.
- Podmaniczky, Michael**  
1994 Report on object no. 58.2242. Winterthur Museum, 15 May.
- Prime, Alfred**  
1969 *The Arts and Crafts in Philadelphia, Maryland, and South Carolina, 1721–1785*. 1929. Reprint, New York: Da Capo Press.
- Sheraton, Thomas**  
1970a *Cabinet Maker's and Upholsterer's Drawingbook*. London, 1793. Reprint, New York: Praeger Publishers.  
1970b *Thomas Sheraton's Cabinet Dictionary*. London, 1803. Reprint, New York: Praeger Publishers.
- Wainwright, Nicholas B.**  
1964 *Colonial Grandure in Philadelphia: The House and Furniture of General John Cadwalader*. Philadelphia: Historical Society of Pennsylvania.
- Watin, Jean Félix**  
1977 *L'art du peintre, doreur, vernisseur*. 1773. Reprint, Paris: Leonce Laget.

# The Use of Dyes and Colored Varnishes in Wood Polychromy

Jonathan Thornton

THE REPORTED PRESENCE of flower pollens in Neanderthal burials indicates that humankind's attraction to brightly colored flowers and plant materials predates *Homo sapiens*. It is not surprising then, that humans have identified and modified the botanical colorants, among other colored substances, in order to decorate themselves, their clothes, and their surroundings. The quest for dyes has motivated trade and exploration for thousands of years, and descriptions of textile dyes and technologies are found in our earliest literature. Dyes have also been important in the decoration of wood, in ways that are both obvious and unexpected.

---

## The Use of Dyes in Wood Polychromy

The functions that dyes fulfill in the decoration of wood can be broken down into the following five categories:

1. Dyes: When woods are actually soaked or boiled in dye solutions with appropriate fixing chemicals, or *mordants*, as was common practice in the dyeing of textiles, they can be said to function as true dyes. Thin wood veneers were commonly dyed during the periods when pictorial marquetry was fashionable. Such dyed veneers are more or less colored throughout their entire thickness.
2. Stains: A superficial application of a colorant or color-producing reagent to wood is commonly called *staining*. Stains are normally applied to completely assembled furniture and woodwork, and penetrate into the wood a short distance only.
3. Colorants for varnishes and glazes: Soluble extracts of dyestuffs, as well as colored resins, were often completely dissolved in drying oils, spirit varnishes, and oil-resin varnishes. When used in this way, they color the medium but are not distributed as particles, except on a molecular level.
4. Lakes: Dyes can be made into insoluble pigments in a variety of ways, and as such are termed *lakes*. These pigments have particle sizes in the range of other ground pigments. Lakes are generally quite transparent in their media, due to low refractive indexes, and were commonly used in oil-medium glazes and colored varnishes. Modern pigments based on reasonably stable synthetic dyes have acquired a legitimate place in the

production of commercial paints, and a few may even be considered permanent.

5. Adulterants: Dyes have long had a leading role in the adulteration of paints and pigments. They have been used to produce outright fakes of more esteemed and expensive pigments, as well as to brighten the colors of paints that have been extended by the addition of inert white fillers.

The categories of use described above may be combined. Soluble dyes, colored resins, and pigments were often incorporated into varnish and stain recipes, or combined on the object as separate procedures.

---

## Definition, Description, Chemistry, and Terminology

### Definition and description

Dyes are organic (carbon-containing) compounds that selectively absorb some wavelengths of visible light. Those wavelengths not absorbed are perceived as color by the viewer. Dyes have always been most important in human technologies as colorants for textiles, and it is from this literature that most of the information regarding them is drawn. In order to be an effective dye, an organic substance must stain or fix well to the substrate, produce a bright color, and retain that color to a reasonable degree. The vast majority of compounds that give rise to color in nature do not satisfy these criteria, and over the centuries the potential plant and animal sources have been winnowed down to relatively few.

### Chemistry and terminology

Most dyes are aromatic organic molecules, based on the six-carbon ring structure of benzene. Attached to this benzene ring are the various functional groups that characterize particular dyes. Molecular structures that absorb light and give rise to colors are termed *chromophores*, “color bearers.” Typical chromophores for the natural red dyes are aromatic molecules classed as *quinones*, of varied individual structure. Quinonoid compounds are quite stable, and some red dyes—such as *madder*, from the roots of the madder plant, whose major colorant has been identified as alizarin—are as lightfast as a natural dye can be.

By contrast, most yellow dyes are flavinoid compounds, having lesser stability, and natural yellow dyes are notoriously fugitive. The most permanent of these is luteolin, from the stems and leaves of the weld plant. However, one of the most fugitive—quercitrin, from oak (*Quercus*) bark—has been most frequently found in historic textiles, probably because of low cost. Chemists have determined that many natural dyestuffs do not yield a single compound, but are mixtures of several compounds; for example, alizarin, purpurin, and pseudopurpurin are the major chromophoric compounds in natural madder (Mills and White 1994). Because dye compounds have varying degrees of stability, natural dyes that are mixtures will often shift in hue, as well as lose overall intensity, as they fade.

Dyes bind to their substrates in a variety of ways that are classified according to their chemical interactions as being *direct*, *acid*, *vat*, *mordant*, et cetera. Most of these interactions are specific to various textile fibers and are outside the scope of this article, although two, mordant and direct, are sufficiently relevant to be commented on briefly. Most natural dyes are mordant dyes, and these have particular relevance to pigment

production. Mordants (from the Latin verb *mordere*, “to bite”) are metal salts, such as alum, which bind with the dye and form an insoluble complex as they are made to precipitate out of solution. This precipitate can be formed on the surface of a fiber (as in textile dyeing) or can be settled out, washed, filtered, and dried to create a pigment. Such dye-based pigments are called *lakes*. Direct (also called *substantive*) dyes are much less common. They bind to polar sites on the substrate without any special treatment. The direct dyes saffron and turmeric, for example, are effective though fugitive dyes for cellulosic fibers such as cotton. They will also dye and stain wood,<sup>1</sup> as it consists mostly of cellulose. *Alkanet* is another direct dye that has been used extensively as a stain (Moore 1882:271).

One dyestuff will often yield different colored complexes when different metallic salts are used as mordants. Such dyes are termed *polygenetic*. Madder, for instance, can be made rust-red with aluminum; violet with iron; orange with tin; maroon with chromium; and yellow with copper. *Cochineal* is another polygenetic dye.

The color afforded by some dyes, such as archil and litmus, both derived from lichens, is pH dependent. The light-absorbing characteristics of the particular chromophore formed will depend on whether the dye-bath is alkaline or acidic, and a variety of reds and purples can be made by manipulating the pH of the dyebath.

The natural dyes and tannins present in many woods can be made darker or brighter, or can be altered in shade by the application of various reagents. For lack of a better term, these internally produced colors have been called *chemical stains*, to indicate that the color has been produced by a chemical reaction between the stain and the materials in the object. Examples of such stains include solutions of salts of metals, such as iron and copper. The metal ions react with the phenolic groups of tannins and lignins in the wooden object to form intensely colored complexes. Similar chemistry is involved in an iron and oak-gall stain, prepared separately and applied to wood to “ebonize” it, or in an iron-mordanted logwood (*Haematoxylon campechianum*) extract, used to dye textiles black. In these and other cases, the term *chemical stain* provides a useful distinction between processes but not chemical products. Other chemical stains include oxidants such as nitric acid (aqua fortis) (Dossie 1758:509), the chromates, and a base such as ammonia—which is used in the gaseous form to give *fumed oak* (Hayward 1946:15) its characteristic appearance. The oxidants presumably convert phenolic materials in the wood to more intensely colored quinone structures, while the ammonia may catalyze a variety of oxidation and condensation reactions resulting in the formation of chromophores. Other stains in the chemical class include the use of verdigris (basic copper acetate) as a green stain for light-colored woods, bone, and ivory. In this case, probably the only chemistry involved is the binding of the copper ion to the cellulose or protein.

---

## Origins of Relevant Colorants

### Natural dyes and colored resins

The naturally occurring dyestuffs are either botanical or animal in origin and are obtained from the roots, stems, flowers, or fruits of plants, or from the exudate (e.g., lac) or actual bodies of insects (e.g., cochineal, kermes). The famous Tyrian Purple that decorated the togas of Roman senators was extracted from *Murex* mollusks of the family Muricidae.



Both natural and synthetic dyes have been used in wood polychromy, but natural dyestuffs have, by far, the longest history of use. Because of this important history, as well as the problems of permanence that have been caused by their use, they are described in greater detail in the appendix at the end of this article. A number of colored resins that were soluble in oils, alcohol, or turpentine were also important in wood polychromy, primarily for the production of clear but colored glazes and varnishes.

### Synthetic dyes

Beginning in the mid-nineteenth century, chemists began to explore the chemical constituents and properties of *coal tar*, the black and gooey by-product of the processes of making coke and flammable gas from coal. In 1856, an eighteen-year-old chemistry student, Henry Perkin, was trying to synthesize quinine from one of the component fractions of coal tar (aniline) and inadvertently produced a bright purple-colored material. This synthetic dye, the first to become commercially available, was marketed as Tyrian Purple and Aniline Purple in 1857 (Knecht and Loewenthal 1910:496). Manufacture was subsequently taken up by the French, who called the color Mauveine (Allen 1971:8). Although Perkin's Mauve, as it came to be called, proved to be quite fugitive, more and better dyes soon followed—Magenta in 1858, Rosaniline Blue and Aniline Black in 1860, Methyl Violet in 1861, Aldehyde Green (the first synthetic green) in 1862, and Hoffman's Violet in 1863, to name a few important ones (Cain and Thorpe 1913:202–4).

In 1865, the benzene ring structure was proposed by August Kekulé (McLaren 1986:15); and, in 1868, the first intentional synthesis of a dye based on this new theoretical understanding produced alizarin, which is one of the most stable and widely used synthetic dyes to this day. Another important class of dyes, the *azo* compounds, began to be synthesized in 1876. By 1910, dye chemistry was well understood and synthetics had replaced all but the most permanent of the natural dyes. The synthetic dye revolution made available new and brighter colors; after the early experimental years, chemists produced synthetic dye colors with far greater permanence than the natural dyes. A few modern synthetic pigments, notably the *phthalocyanine* and *quinacridone* colors, have been placed by Winsor and Newton in their second, "durable" category and may well belong in category one, "extremely permanent" (Thomson 1978:11–12).

---

### History of Use

There is extensive documentary evidence for the use of dyes in a wide variety of the decorative arts, including painted wood. The earliest relevant treatises of a practical nature—such as the *Mappae Clavicula*, a ninth-century compilation (Smith and Hawthorn 1974); and the *Strassburg Manuscript*, attributed to either the fourteenth or fifteenth century (Borradaile 1966)—contain recipes for dye-based colors, but difficulties of translation and interpretation make it hard to say how these recipes were used. Among the dye colors intended for painters mentioned in the *Mappae Clavicula*, parts of which can be traced back to ancient Greek and Roman sources, are indigo, woad, lac, "earth vermilion that grows on the leaves of the turkey-oak" (kermes), and a "broth made from boiling down Murex."

The evidence is discussed in greater detail in the following, according to the categories of use already described.

### Dyes and stains

Early treatises rarely distinguish between the use of natural colorants as true penetrating dyes and as superficial stains, and in practice most can be used in either way. The mid-eighteenth century saw an increase in technical treatises describing actual current practice. One of the best of these, Robert Dossie's *Handmaid to the Arts* (1758), contains a lengthy section on stains for wood, including: "tincture of turmeric" (a tincture is an alcoholic solution) and stains based on brazilwood, indigo, madder, fustic, "yellow berries" (buckthorn berries), dragon's blood, and logwood. Another eighteenth-century manual describes a stain made by propping the freshest possible horse manure up on little sticks and collecting the drippings, which would "penetrate [the wood] so as to never fade or vanish" (Smith 1799:267). This, no doubt, had the advantage of a plentiful supply of the raw material.

In 1803, Thomas Sheraton stated that "the art of staining wood was more in use at the time when inlaying was in fashion" and that red and black were the colors currently in use (Sheraton 1970:308). Manuals of the nineteenth century continued to list a wide variety of stain recipes, among the most common of which were those based on barberry and alkanet roots, logwood and brazilwood, indigo, and iron/insect-gall complexes. By the early twentieth century, synthetic dyes replaced natural dyes for all but the most stubbornly traditional artisans. *Coal tar* dyes, as they were still often called, were available in the form of dry crystals that were either water or oil soluble. Water-soluble stains offered a wider range of colors but were somewhat less fast than those soluble in oil (which were usually the highly stable azo dyes).

### Colorants for varnishes and glazes

Many dyes are soluble in oils or alcohol and can be used to form bright and transparent media for decorative painting. Most of these early recipes were intended for use over white metal leafs (silver, tin) to give them the appearance of gold. Such *changing varnishes*, as they were sometimes called, are included in many formularies. One from the *Mappae Clavicula* was composed of saffron, gum, linseed oil, and orpiment. Annatto is an oil-soluble dye that was widely used in this way, and in fact its chief modern uses are in the coloring of butter, cheese, and margarine, and in cosmetics. The dyewoods were also commonly included in such recipes. Early craftsmen were often aware of the limitations of dye colorants. Dossie (1758:119) said that annatto was not fast in oil or water media but was fast in "varnish painting." The most common use of dye colorants, however, was in the form of lakes used to produce translucent glazes for fine and decorative painting.

### Lakes

Lakes probably originated as the insoluble dye-vat scums and sediments left over from the mordant dyeing of textiles, but they were intentionally made as pigments as early as the Roman period. The name itself came from *lac*, the red dye washed from shellac resin, but was later generalized

to encompass all dye-based pigments. An earlier term for lakes in English was *pinks*, hence the confusing name of *dutch pink* for a yellow lake made from buckthorn berries (Harley 1970:97).

In addition to their attractive, bright colors, the transparency of lakes made them popular with artists for the vehicle-rich paints called *glazes*. Lakes had a solid place in the fine arts but were particularly important in decorative and commercial painting. Such decorative products as japanned “tin” wares (made from tinned sheet iron) and papier-mâché used colored glazes extensively, often over metal leafs and mother-of-pearl inlays. Of the colors listed in one Victorian manual for amateur decorative painters, many are lakes (*Art Recreations* 1866:156, 188). An early twentieth-century writer on paint technology stated that “automobile and carriage painters use lakes extensively for high class work, and decorative artists also use them.” Of the colors listed as “decorators’ glaze colors,” well over half are lakes (Vanderwalker 1924:25, 52). In the painting of wooden vehicles, lakes were traditionally used as glazes over similar colors—carmine over red lead, and yellow lake over ochre, to give two examples (Schriber 1910:24).

With the development of the synthetic dyes, the number of paints based on dyes skyrocketed. An early-twentieth-century authority complained that “there are on the market today a great many unnecessary colors . . . many aniline or dye colors, titled with misleading or alluring names, which mean nothing, but serve only to attract the unsuspecting buyer” (Weber 1923:3).

### Adulteration

The confused state of nomenclature alone meant that artists were often unaware of what they were actually using. This was particularly true owing to the widespread adulteration of colors by manufacturers and dealers. An excellent recent article by Leslie Carlisle (1993) on the adulteration of pigments places these practices in the context of a time when even the dealers in foodstuffs thought nothing of faking or “improving” their products with deadly poisons. It seems that merchants of the eighteenth century would have regarded themselves as rubes if they did not engage in the “sophistication” (faking) of their wares.

These shady practices were so prevalent that, in his extensive descriptions of the properties and preparation of pigments, Dossie (1758:43–143) included information on how they were commonly adulterated and how this could be found out by the careful craftsman. He described three modes of pigment adulteration: dilution with cheaper materials, color enhancement, and outright substitution. He warned that whatever is added to Prussian blue to “sophisticate it” (probably logwood lake) “will always render it more foul and purple.” Smalt was added to ultramarine. Even a cheap pigment such as ochre didn’t escape having its brightness boosted up by the addition of fugitive *dutch pink*. Indigo, verditer, chalk, “and other cheap substances” were substituted for bice; and fugitive logwood lakes were sold as the expensive carmine made from cochineal.

Adulteration and substitution continued to be common enough in this century for various writers to issue warnings. Among them were F. W. Weber in his book *Artists’ Pigments* (1923:18, 26, 78). He lists “American vermilion . . . with many fanciful synonyms” as consisting of red lead and

the highly fugitive synthetic dye eosin. The already fugitive “brown pink” (formerly made from buckthorn berries) consisted of the still more fugitive quercitron, but only if “genuine.” While the cheaper lakes were often used to adulterate other pigments, they themselves were extended by the addition of starch.

When the synthetics were well established, it became standard practice to use them in paint manufacture. Weber (1923:45) stated, “When some of the more permanent lake pigments . . . are used in admixture . . . they can not be looked upon as adulterants but are safe combinations producing a more colorful pigment.” This view was apparently not universally accepted. Maximilian Toch, in his *Materials for Permanent Painting* (1911:87), along with other warnings against synthetics, said that alizarin greens were made from coal-tar dyes that “readily decompose when mixed with iron oxide colors.” It was generally accepted, however, that cheap and potentially fugitive colors had their place. Ralph Mayer (1940:92) argued that “nobody expects the paints used in ordinary wall decoration to last fifteen years,” and a wagon painter said that “on cheap work *munich lake* is substituted for *carmine* and few can tell the difference” (Schriber 1910:49). The *Painting and Decorating Craftsman’s Manual and Textbook* (1949:31) listed rose lake as sufficiently permanent for interior work, tinting, glazing, and stains. Thus we see that the paints used on much of our material heritage may be either less permanent than intended or not intended to be permanent.

---

## Aging and Permanence of Dyes

### Technical discussion

Dye chemistry is highly complex, and the mechanisms of degradation vary with molecular structure. A few generally agreed-upon statements can be made, however.

Dyes fade in direct proportion to the total light energy they receive. They will not be protected from damage by the maintenance of low light levels but only damaged more slowly. The reciprocity law tells us that decreasing total illuminance by half will cut the rate of damage by half. It is also true that halving the time of exposure under the full level of illuminance will cut the damage by half. The rate of fading, however, has an exponential relationship to exposure, with the most damage happening initially and decreasing in rate over time (Thomson 1978:22).

For most materials, the damage caused by light increases as wavelength decreases. The blue and violet end of the spectrum is more damaging than the red because more photochemistry is initiated by these higher energy photons. In the museum display of sensitive objects, it is both practical and advantageous to exclude damaging ultraviolet light because it contributes nothing to illumination, but the visible light is equally damaging to many dyes and cannot be removed except by colored filters, which are aesthetically unacceptable. Highly light-sensitive dyes are damaged most by the wavelengths they absorb most strongly (McLaren 1956), and it is precisely this selective absorption that makes them colored.

While light is the primary factor in the degradation of dyes, it is not the only one. The chemical mechanisms of fading are many and varied and are not prone to generalization. The longevity of most dyes can be prolonged by a reduction in humidity level. Reduction of oxygen concentration will reduce the fading of most but not all pigments and dyes (Arney, Jacobs, and Newman 1979). Prussian blue, to cite just one

example, fades rapidly in a vacuum but not in air. Gaseous pollutants, such as ozone (Cass et al. 1989), nitric acid (Salmon and Cass 1993), and nitrogen dioxide (Whitmore and Cass 1989), have also been identified as agents of deterioration.

The degradation of dyes depends on the molecular structure of the chromophore. Flavins, which account for most natural yellow dyes, are far more fugitive than quinones, such as cochineal and other reds, but the rate and type of alteration that dyes undergo is very much dependent on other components of the total system, such as mordant and substrate. Most research has been done on textile dyes, but the findings demonstrate the complexity of these considerations. Many textile dyes are more stable with a chrome mordant. Madder is more stable on cotton than on wool, while just the opposite is true of indigo (Padfield and Landi 1966). Dyes that have simply been dissolved in a medium are likely to be more fugitive than those that are present in the form of lakes.

The author carried out informal fading tests on a variety of organic lakes based on annatto, turmeric, brazilwood, logwood, cochineal, and buckthorn berries, made according to historic recipes taken mostly from Dossie. The lakes were painted onto white tiles in linseed oil, animal-glue size (distemper), and shellac (Behlen Brothers' Super Blonde). They were set on a windowsill and exposed to direct sunlight for six months, the tiles half-covered with foil. The results can be summarized as follows: All of the colors were markedly faded, with the greatest color loss shown by the annatto and the turmeric (the latter virtually disappeared), followed by the logwood and brazilwood colors. All colors were least fast in glue size, but were faded to roughly the same degree in oil and shellac, with the exception of cochineal, which showed somewhat greater permanence in the oil glaze. The presence of tin chloride in one brazilwood lake recipe appears to have rendered the color less permanent than a similar brazilwood lake on an aluminum hydroxide substrate alone (Fig. 1).

Figure 1

Organic lakes after six months of fading in sunlight with the right side of each test tile covered with foil. The media are, from top to bottom on each tile, linseed oil, animal-glue size, and shellac. The colors are, top left, buckthorn berry "dutch pink"; top right, brazilwood purple; middle left, cochineal "carmine"; middle right, brazilwood red; bottom left, logwood red; bottom right, brazilwood purple with tin chloride.

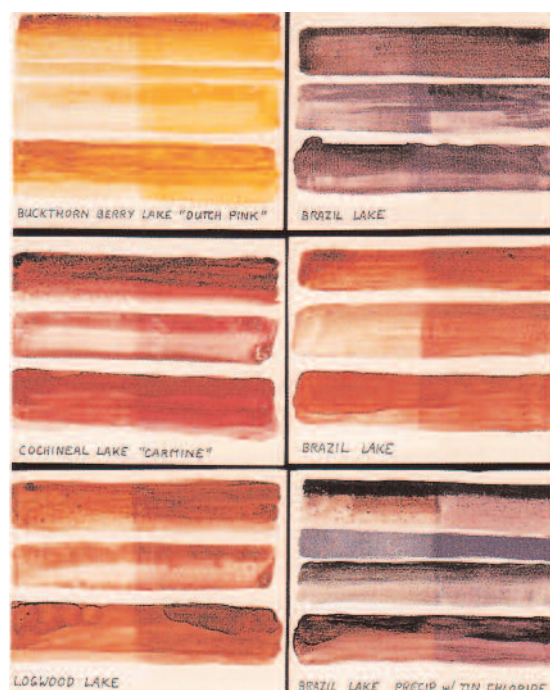

Similar fading tests were carried out on mixtures of some of the colored resins and shellac and showed the following results: accroides showed no discernible alteration; gamboge was also quite fast, showing only a slight brightening of the yellow hue as an original brown tone was lost; aloes lost its original greenish brown cast and became a darker amber color; and dragon's blood was almost entirely bleached out.

## Historical discussion

The fact that dyes fade in light has been appreciated for centuries and has been the subject of scientific investigation since the early eighteenth century. Dossie (1758:102, 60) warned that "all colors formed of vegetables are very uncertain with respect to their standing" and that "some will fly in a degree that makes the use of it destructive to any painting." The best of the natural dyes, such as indigo and madder, were still liable to fade in time, and Toch (1911:24) recommended that indigo be excluded from the palette. His views did not control the market, however, as he complained that "there are about 215 tube colors for sale today . . . and out of this entire amount there are not over twelve that may have any possible use." After the introduction of synthetic dyes, consumers' enthusiasm for certain colors kept those colors in production even after scientists knew them to be impermanent. In 1901, a scientist wrote, "Pigments produced from artificial colourings [except alizarins, azos, and naphthols] are not fast to exposure to light, air, and moisture; some are much faster than others, but the most fugitive are usually the most brilliant and give the most pleasing shades; hence they are largely in demand" (Jennison 1901:108). Some were particularly popular and eventually notorious. Toch (1911:126) said that, from the 1870s on, eosin dye had been used to create a great many popular and brilliant lakes; he went on to say that eosin begins to bleach in only twenty-four hours (Fig. 2).

The extreme instability of some early synthetic dyes gave rise to the mistaken notion that natural dyes were more stable and tended to only "mellow" rather than fade. In fact, all of the natural dyes are less fast than the best modern synthetics. None of the natural yellow dyes can be regarded as fast by current standards. Two of the most fugitive natural dyes—logwood and quercitron—are the most likely to have been used as adulterants or replacements for more expensive colorants, due to their low cost.

Traditional practice often dictated ways in which the life of organic colorants could be prolonged. Toch (1911:189) said that "painters as a rule know that no earth color or metallic color should be mixed with a lake," but that they could be used as glazes over thoroughly dry colors. This tendency for lakes to be discolored by admixtures of many metal-compound pigments was noted by other writers. Dossie (1758:174) even recommended the use of a horn palette knife to take lakes off the grinding stone, so as not to "greatly injure the color." An early-nineteenth-century guide stated that fading was caused by "not using anything but simply the infusion of coloring materials, without adding anything to set [mordant] the color as we have recommended" (*Cabinet Makers Guide* 1825). Among other miscellaneous instructions for sound practice was the recommendation that gamboge be enhanced in permanence in an oil paint by the addition of copal resin or wax (Weber 1923:57), and that dutch pink was suitable for water-colors, but should not be worked in oils (Dossie 1758:101).

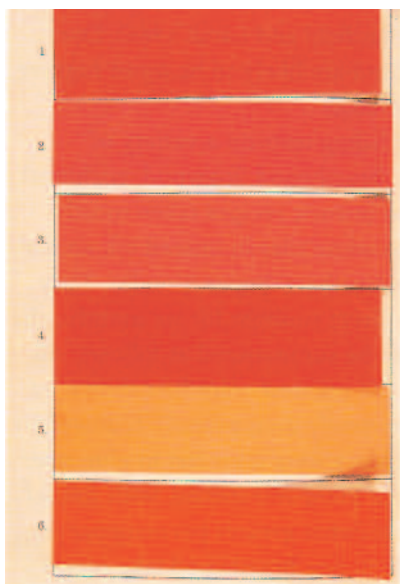

Figure 2  
Paint samples made from synthetic lakes, based on eosin dye, that have been protected from light since manufacture and so are probably little altered (from Jennison 1901:70, pl. 3).

---

## Identification

The conclusive identification of dyes is complicated in both theory and practice, and has been briefly summarized by Mills and White (1994:129). In some cases no method has yet been developed for unequivocal identification. Success is dependent not only on choosing the appropriate method but also on considerable skill and experience in carrying out the analyses, as well as interpreting the results. The techniques most often used include chromatographic techniques that separate the sample into its component parts, such as thin-layer chromatography (TLC) and high-pressure liquid chromatography (HPLC), as well as spectrophotometric techniques that rely on comparing the spectral absorption, reflectance, or fluorescence of an unknown with reference samples of known composition and structure. These include ultraviolet-visible spectroscopy (UV/Vis) and Fourier-transform infrared (FT-IR) spectroscopy (Gillard et al. 1992).

Recent experience at the Conservation Department of Buffalo State College indicates that TLC offers an excellent and reasonably simple and inexpensive method of identifying dye colorants, even in extremely small samples. Best results have been achieved with polyamide TLC plates examined after development under ultraviolet light. This technique gives distinctive "fingerprints" of unknowns. Simple visual comparison of known substances treated in the same way will usually identify the unknown colorant, but results can be confused by the presence of degradation products or other materials extracted into a coating film from the underlying wood.

In a few instances, there are even simpler identification techniques. Some dyes fluoresce strongly and distinctively in ultraviolet light. Lac fluoresces orange; madder, orange-red; and dutch pink, yellow. Microchemical tests are available for many dyes. Dye analysis has been extensively discussed in the literature, most notably in the work of Helmut Schweppe (1963:12; 1977; 1987) and Judith Hofenk de Graaff (1969; 1974:54; Hofenk de Graaff and Roelofs 1978).

---

## Conclusion

Organic dyes have long been important components in colored coating systems such as paints, glazes, and colored varnishes, which differ from one another only in binder-to-colorant ratios. The artists' preoccupation with immediate effect, as opposed to permanence, is nothing new. Painters have used dye-based colorants for their often stunning brilliance, as well as for the broader palette and the transparent effects they offer. This disregard for permanence was especially true in the so-called decorative arts, due to the lower status accorded to these objects in Western culture, whereas the products of fine artists were expected to last. The inclusion of dye-based colorants, however, was often outside the artist's or artisan's control, due to the common practices of dilution, adulteration, and outright fakery carried on by manufacturers and merchants.

Most of the natural dyestuffs are so fugitive that the historic literature is a better guide to actual practice than the present appearance of the objects themselves. The original appearance of many historic painted surfaces can only be surmised, but the knowledge that the current appearance is likely to be a muted shadow of the original, and that fugitive materials may be present on the most unexpected objects, can add greatly to our understanding of period taste and practice. This understanding should inform our decisions with regard to preservation, conservation, and restoration.

## Acknowledgments

The author would like to thank his colleagues Judy Bischoff and Chris Tahk for helpful comments on sections of the manuscript dealing with chemistry, and former student Scott Nolley for information drawn from his research project (under the direction of Judy Bischoff) on thin-layer chromatography as a method of identifying organic dyes in coatings.

## Appendix

Tables 1 and 2 list common natural materials known from the literature to have been used in stains, paints, and glazes. It is likely that many more have had a limited and local use in the decoration of wood than are listed here because thousands of plants have been used to make colorants. This list concentrates on those that were widely traded or propagated worldwide. Most of these would have been available from apothecary shops and were sometimes called *dyer's drugs*. The most common name for the dyestuff is given first, followed by a few synonyms (including the names of lakes made from it), and then the source (seed, root, etc.) and taxonomy. Many of the popular names are drawn from Gettens and Stout (1942), and Mayer (1940).

The currently accepted botanical name is shown in boldface, and the authority given. Superseded names are listed in parentheses. Where no authority can be found the name may still be listed (but not in boldface) as a cross reference and may be either a superseded synonym or a valid name that could not be confirmed from the sources consulted (Bailey and Bailey 1972; Stafleu 1972; Uphof 1968; Willis 1973). More complete treatises on natural dyes have been published, but these works contain obsolete or unconfirmed botanical nomenclature (Liles 1990; Hofenk de Graaff 1969; Perkin and Everest 1918). Because of the polygenetic nature of many of these dyes, the color classification is somewhat arbitrary.

Table 1 Natural dyes

Common name	Synonyms	Source
<b>Yellows and Browns</b>		
annatto	arnato roucou orange lake	Seeds, or pod surrounding seeds, of <i>Bixa orellana</i> L.
barberry		Bark, stems, and root wood of <i>Berberis vulgaris</i> L.
buckthorn berries	yellow carmine avignon berries yellow berries french berries	Berries from various species of the <i>Rhamnus</i> (buckthorn) genus, such as <i>R. amygdalinus</i> , <i>R. oleoides</i> , <i>R. saxatilis</i> Jacq., <i>R. cartharticus</i> L., <i>R. alaternus</i> L., and <i>R. infectoria</i> L. ("Persian berries"). The berries were used to make the lakes known as <i>dutch pink</i> (also called "brown pink" and "Italian pink"), and to make <i>Stil de Grain</i> .
fustic	old fustic dyer's mulberry yellow wood cuba wood	Wood of <i>Clorophora tinctoria</i> L. <b>Gaudich.</b>
galls	gall nuts	Abnormal growths caused by insects on various oaks ( <i>Quercus</i> spp.), such as <i>Quercus infectoria</i> .
madder	brown madder burnt carmine Rubens madder	Made by partially charring madder lake (see madder under "Reds and Purples").
onions		Outer husks of onion bulbs, <i>Allium cepa</i> L.



Common name	Synonyms	Source
<b>Yellows and Browns</b> (continued)		
osage orange		Wood of <i>Maclura pomifera</i> (Raf) C. K. Schneid.
quercitron	quercitron lake flavine lake	Bark of <i>Quercus citrinia</i> , <i>Quercus velutina</i> Lam., ( <i>Quercus tinctoria</i> Bartr.).
saffron		Flower stiles of <i>Crocus sativus</i> L.
sumac		Wood of <i>Rhus cotinus</i> L., <i>Cotinus coggygia</i> Scop. (Venetian sumac called <i>Zante</i> or <i>Young Fustic</i> ), <i>Rhus coriaria</i> L. (Sicilian sumac), <i>R. typhina</i> L. (American "staghorn" sumac).
turmeric		Rhizomes of <i>Curcuma domestica</i> Val. ( <i>C. longa</i> L.), <i>C. tinctoria</i> , <i>C. veridiflora</i> Roxb.
walnut		Bark, leaves, and nut husks of <i>Juglans nigra</i> L. (American black walnut), <i>J. regia</i> L. (English walnut), and <i>J. cineria</i> L. (butternut, or "white walnut").
weld	arzica dyer's broom dyer's weed	Leaves and stems of <i>Reseda luteola</i> L. The term <i>Dyer's Broom</i> is also used for <i>Genista tinctoria</i> L. ( <i>G. spartium</i> Roth.), which does not yield as bright a color as weld.
<b>Reds and Purples</b>		
alkanet	bugloss violet carmine	Roots of <i>Anchusa officinalis</i> L. ( <i>A. tinctoria</i> Lamm.).
archil	archal french purple litmus lacmus cudbear	Numerous lichen species of the <i>Evernia</i> , <i>Rocella</i> , <i>Ramalina</i> , and <i>Usnea</i> genera, including <i>Evernia prunastri</i> (L.) Ach., <i>Rocella phycopsis</i> Ach. (identified as "archil"), and <i>Ramalina scopulorum</i> Ach. <i>Turnsole</i> , another lichen dye, is from <i>Crozophora tinctoria</i> .
brazilwood	rose pink hypernic wood	Wood from various tree species of the genus <i>Caesalpinia</i> , such as <i>C. braziliensis</i> Sw. ("brazilwood," "bahia wood," "Brazilian redwood"); <i>C. crista</i> L. ("pernambuco wood," "braziletto"); <i>C. sappan</i> L. ("sapan wood"); <i>C. echinata</i> Lam. ("peach wood," "Nicaragua wood"); and <i>C. vesicaria</i> ("Jamaica redwood"). <i>C. sappan</i> L. was known and traded from the Far East long before the discovery of the New World. It was the discovery of these valuable dyewoods in modern Brazil that named the country and not as is often supposed, the country that gave its name to the wood (Mills and White 1994:122).
cochineal	carmine nacarat venice lake	From the bodies of the scale insect <i>Dactylopius coccus</i> Costa. ( <i>Coccus cacti</i> L.), living on various nopal cacti, such as <i>Opuntia coccinillifera</i> (L.) Mill.
henna		From the leaves of <i>Lawsonia alba</i> Lam.
kermes	crimson grain	From the scale insect <i>Kermes vermilio</i> Planch, found in southern Europe, North Africa, the Near East, and some Greek islands, living on the kermes oak, <i>Quercus coccifera</i> L. Less commonly used red dyes were extracted from the Northern European scale insect <i>Porphyrophorus polonicus</i> L. ("Polish red," "St. John's blood"); <i>Coccus fragariae</i> and <i>C. uvae ursi</i> from Russia; and <i>Porphyrophora hamelii</i> from Armenia.
lac	lac lake indian lake	Dye washed out of the secretions of the scale insect <i>Laccifer lacca</i> Kerr. ( <i>Coccus laccae</i> L.), living on various species of the genus <i>Ficus</i> .
logwood	campeachy wood peachy wood	Wood of <i>Haematoxylon campechianum</i> L.
madder	alizarin <i>Garance</i> (Fr.)	Outer portion of the roots of various species of the <i>Rubia</i> genus, primarily <i>Rubia tinctorum</i> L., cultivated worldwide, but also <i>R. peregrina</i> L. ("levant madder"), cultivated in Persia and the Mediterranean area, and <i>R. cordifolia</i> L. ( <i>R. mungista</i> [munjeet, in Hindi], is probably a synonym) from India.
safflower	dyer's saffron <i>carthame</i> (Fr.)	Flowers of <i>Carthamus tinctorius</i> L.
<b>Blues</b>		
indigo		From the leaves and stems of various plant species that bear the active principal <i>Indigotin</i> , principally <i>Indigofera tinctoria</i> L., originally from India. A European plant

Common name	Synonyms	Source
<b>Blues</b> (continued)		
		yielding indigo was <i>Woad</i> ( <i>Isatis tinctoria</i> L.). The indigo-yielding plant <i>Polygonum tinctoria</i> Ait. was used in Korea and Japan.
<b>Greens</b>		
Most greens were made by combining blue and yellow dyes.		
chinese green indigo		Berries of <i>Rhamnus chlorophora</i> Decne.
sap green		Juice from unripe buckthorn berries (see "Persian berries"), particularly <i>Rhamnus cathartica</i> L., used primarily in watercolor painting as a lake pigment, or as a concentrated extract.

Table 2 Colored resins and resinous woods

**Colored Resins**

accroides		Red resin from various species of the grass tree genus <i>Xanthorrhoea</i> , such as <i>X. hastilis</i> R. Br. native to Australia.
aloes		Yellow-brown resin from various members of the <i>Aloe</i> genus, such as <i>A. vera</i> L., <i>A. ferox</i> Mill. ("cape aloes," "Hepatic aloes"), and <i>A. perryi</i> Baker ("Socotran aloes").
dragon's blood		Red resins from various species of the genus <i>Dracaena</i> in the Liliaceae family were probably first used in Europe as "dragon's blood." These included <i>D. draco</i> L. ("dragon's blood," "Sanguis Draconis"); <i>D. cinnabari</i> Balf. f. ("Socotra dragon's blood") from the island of Socotra; and <i>D. schizantha</i> Baker ("Arabian dragon's blood," "Socotra dragon's blood"). More recently it has been derived from various species of the <i>Daemonorops</i> genus in the Palmae family, such as <i>Daemonorops draco</i> Blume ( <i>D. propinquus</i> may be a synonym).
gamboge	gummigut	Yellow resin from <i>Garcinia hanburyi</i> Hook. f.
seedlac		Raw product of the lac insects, still often brightly colored after an initial washing to remove most of the dye. Other grades of "shellac" and "button lac" may also be brightly colored, due in part to natural colorants but also to the common addition of cinnabar or orpiment in India.

**Resinous woods**

Some dyewoods are termed *insoluble* because the colored resins are not water soluble. They have been used primarily to color lacquers and varnishes.

camwood	camewood kambe wood	Wood of <i>Baphia nitida</i> Lodd. "Barwood" is probably a synonym for camwood, for it, too, has been identified as <i>B. nitida</i> .
eagle wood	agal wood calambac aloes wood	Wood from <i>Aquilaria agallocha</i> Roxb. ( <i>Aloepaticum citrinum</i> may be another name).
red sandalwood	red saunders wood sanders wood padauk	Wood of <i>Pterocarpus santalinus</i> L. f. Related woods containing brightly colored resins are <i>P. draco</i> L. ("West Indian dragon's blood") and <i>P. soyauxii</i> Taub. ("African padauk").

**Note**

- 1 For the dyeing and staining of wood with saffron and with turmeric, see Baird (1886:393) and Dossie (1758:508), respectively.

**References**

- Allen, R. L. M.  
1971 *Colour Chemistry*. New York: Appleton-Century-Crofts.

- Arney, J. S., A. J. Jacobs, and R. Newman  
1979 The influence of oxygen on the fading of organic colorants. *Journal of the American Institute for Conservation* 18(2):108–17.
- Art Recreations*  
1866 Boston: J. E. Tilton.
- Bailey, L. H., and Z. B. Bailey  
1972 *Hortus Third: A Concise Dictionary of Plants Cultivated in the U.S. and Canada*. New York: Macmillan.
- Baird, H. C., ed.  
1886 *The Techno-Chemical Receipt Book*. Philadelphia: Henry Carey Baird.
- Borradaile, V.  
1966 *The Strassburg Manuscript: A Medieval Painter's Handbook*. Trans. R. Borradaile. New York: Transatlantic Arts.
- Cabinet Makers Guide, The*  
1825 London: Knight and Lacy.
- Cain, J. C., and F. J. Thorpe  
1913 *The Synthetic Dyestuffs and Intermediate Products from Which They Are Derived*. London: Charles Griffin.
- Carlisle, L.  
1993 Authenticity and adulteration: What were 19th century artists really using? *The Conservator* (17):56–60.
- Cass, G. R., J. R. Drusik, D. Grosjean, W. W. Nazaroff, P. M. Whitmore, and C. L. Wittman  
1989 *Protection of Works of Art from Atmospheric Ozone*. Marina del Rey, Calif.: Getty Conservation Institute.
- Dossie, R.  
1758 *The Handmaid to the Arts*. Vol. 1. London: J. Nourse Bookseller.
- Gettens, R. J., and G. L. Stout  
1942 *Painting Materials: A Short Encyclopedia*. New York: D. Van Nostrand.
- Gillard, R. D., S. M. Hardman, R. G. Thomas, and D. E. Watkinson  
1992 The detection of dyes by FTIR microscopy. *Studies in Conservation* 39(3):187–92.
- Harley, R. D.  
1970 *Artist's Pigments, c. 1600–1835*. New York: Elsevier.
- Hayward, C. H.  
1946 *Staining and Polishing*. London: Evans Brothers.
- Hofenk de Graaff, J. H.  
1969 *Natural Dyestuffs: Origin, Chemical Constitution, Identification*. Amsterdam: International Council of Museums (ICOM) Committee for Conservation.
- 1974 A simple method for the identification of indigo. *Studies in Conservation* 19(1):54–55.
- Hofenk de Graaff, J. H., and W. G. Th. Roelofs  
1978 The analysis of flavinoids in natural yellow dyestuffs occurring in ancient textiles. In *ICOM Committee for Conservation 5th Triennial Meeting*. Zagreb.
- Jennison, F. H.  
1901 *The Manufacture of Lake Pigments from Artificial Colours*. London: Scott, Greenwood.

- Knecht, E., C. Rawson, and R. Loewenthal  
1910 *A Manual of Dyeing*. Vol. 2. London: Charles Griffin.
- Liles, J. N.  
1990 *The Art and Craft of Natural Dyeing*. Knoxville: University of Tennessee Press.
- Mayer, R.  
1940 *The Artist's Handbook*. New York: Viking Press.
- McLaren, K.  
1956 The spectral regions of daylight which cause fading. *J. Society of Dyers Colourists* 72:86–99.
- 1986 *The Colour Science of Dyes and Pigments*. Bristol: Adam Hilger.
- Mills, J. S., and R. White  
1994 *The Organic Chemistry of Museum Objects*. 2d ed. London: Butterworths.
- Moore, R.  
1882 *The Universal Assistant and Complete Mechanic*. New York: R. Moore.
- Padfield, T., and S. Landi  
1966 The light-fastness of the natural dyes. *Studies in Conservation* 11(4):181–95.
- 1949 *Painting and Decorating Craftsman's Manual and Textbook*. New York: Theo. Audel.
- Perkin, A. G., and A. E. Everest  
1918 *The Natural Organic Colouring Matters*. New York: Longmans, Green.
- Salmon, L. G., and G. R. Cass  
1993 The fading of artist's colorants by exposure to atmospheric nitric acid. *Studies in Conservation* 38(2):73–91.
- Schriber, F.  
1910 *The Complete Carriage and Wagon Painter*. New York: M. T. Richardson.
- Schweppe, H.  
1963 Qualitative analysis of organic pigments. *Paint Technology* 27(8):12–19.
- 1977 Thin layer chromatography. Chap. 2 in *Analytical Chemistry of Synthetic Dyes*, ed. K. Venkataram. New York: John Wiley and Sons.
- 1987 *Practical Information for the Identification of Early Synthetic Dyes*. Washington, D.C.: Conservation Analytical Laboratory, Smithsonian Institution.
- Sheraton, T.  
1970 *Cabinet Dictionary*. 1803. Reprint, New York: Praeger.
- Smith, C. S., and J. G. Hawthorn, eds.  
1974 *Mappae Clavicula: A Little Key to the World of Medieval Techniques*. Transactions of the American Philosophical Society. Vol. 64, pt. 4. Philadelphia: American Philosophical Society.
- Smith, G.  
1799 *The Laboratory or School of Arts*. 1740. Reprint, London: C. Whittingham.
- Stafleu, Frans Antonie, ed.  
1972 *International Code of Botanical Nomenclature*. Utrecht: Oosthoek.

- Thomson, G.  
1978 *The Museum Environment*. London: Butterworths.
- Toch, M.  
1911 *Materials for Permanent Painting*. New York: D. Van Nostrand.
- Uphof, J. C. Th.  
1968 *Dictionary of Economic Plants*. 2d ed. Lehre: Verlag Von J. Cramer.
- Vanderwalker, F. N.  
1924 *The Mixing of Colors and Paints*. Chicago: Frederick J. Drake.
- Weber, F. W.  
1923 *Artists' Pigments*. New York: D. Van Nostrand.
- Whitmore, P., and G. R. Cass  
1989 The fading of artist's colorants by exposure to atmospheric nitrogen dioxide. *Studies in Conservation* 34(2):85-97.
- Willis, J. C .  
1973 *A Dictionary of the Flowering Plants and Ferns*. 8th ed., rev. H. K. A. Shaw. Cambridge: Cambridge University Press.

# Verte Antique Decoration on American Furniture

## History, Materials, Techniques, Technical Investigations

Robert D. Mussey Jr.

THE TERM *verte antique*, or *antique verte*, is commonly used today to describe a diverse set of faux painting and gilding techniques intended to make wood, plaster, or metal appear like naturally patinated or corroded bronze castings. James Pilkington described the intent in his 1841 publication, *The Artist's Guide and Mechanic's Own Book* (1856:99), as follows: "Bronze of good quality acquired, by oxidation, a fine green tint, called patina antiqua. Corinthian brass received in this way, a beautiful clear green color. This appearance is imitated by an artificial process called bronzing."<sup>1</sup> While the term *verte antique* is found in late-eighteenth- and early-nineteenth-century documents, it appears that it was not the most commonly used term in the period. Other names such as *bronzing*, *bronzing in gold* or *copper*, *sea green*, and *patina antiqua* are found in printed and manuscript sources of the period. *Verte antique* does not appear to have been adopted as a term until much later in the nineteenth century, but it is the name most frequently used today and therefore will be used throughout this study.

It is commonly assumed that *verte antique* techniques were first developed in France, and later adapted in England and the United States, paralleling an increased interest in the Neoclassical. A search of late-eighteenth-century French sources revealed no references to the actual term *verte antique*. Jean-Félix Watin (1776) does not use the term in his influential volume, *L'art du peintre, doreur et vernisseur*, but he does describe *bronzage*, or *bronzing*, on brass and steel, which was the use of a tinted, baked varnish to make baser metals appear like gold. André Jacob Roubo, writing in 1769–75, does not mention the term *verte antique* in his definitive encyclopedic review of the French woodworking trades of the 1760s and 1770s, *L'art du menuisier* (1977:pt. 3, sect. 3).

---

### Transmission of Techniques to America

The vast majority of American furniture with *verte antique* decoration can be documented or reasonably attributed to Philadelphia or New York. Isolated examples have been attributed to Providence, Rhode Island, and Charleston, South Carolina, as will be seen in cases discussed later; but Philadelphia and New York also were the principal cities to which French-born and trained artisans immigrated. The consensus among furniture historians is that most had fled the excesses of the French Revolution and the Directorate. Prominent among these craftspersons were Charles Honoré

Lannuier,<sup>2</sup> Michel Bouvier, Joseph Brauwers, John Greuz, and Antoine (later Anthony) Quervelle.<sup>3</sup>

New York and Philadelphia became fertile ground for expression of the new Classical ideals that artisans such as Lannuier and Quervelle could supply to an expanding style-conscious and wealthy merchant class. As early as 1795, Anthony Rénaud Jr. advertised his services in New York as “Painter Gilder and Varnisher from Paris,” and a Monsieur Pascal called himself “French Upholsterer” (Garrett 1992). However, examination of relevant post-Revolutionary War records for Boston provided no positive identification of any French furniture craftsmen who moved there during the period 1785–1810 (Talbot 1974). A recent study by the author documented that only one cabinetmaker born outside Boston, John Cogswell, moved there and became successful as a local furniture craftsman between 1760 and 1785 (Mussey and Haley 1984).

It appears likely that the artisans themselves were the primary vectors for transmission of the verte antique traditions to the United States. Whether Lannuier, Bouvier, Quervelle, and other cabinetmakers actually did their own gilding and verte work seems questionable, since they were trained in a craft environment with severely defined specializations. Further research may shed more light on who actually did the decoration, but this article will refer to the verte antique of Lannuier and Quervelle.

---

## Documentary Sources for Materials and Techniques

The techniques used to create various forms of verte antique are described in a variety of nineteenth-century French, British, and American sources, growing in frequency with time. The 1837 French guidebook, *Nouveau manuel complet du bronzage des métaux et du plâtre* (Fig. 1), deals largely with formulas for chemical patination of bronze, copper, and brass, but also

Figure 1

This manual includes important historical formulations and precise descriptions of bronze patination colors of the period.

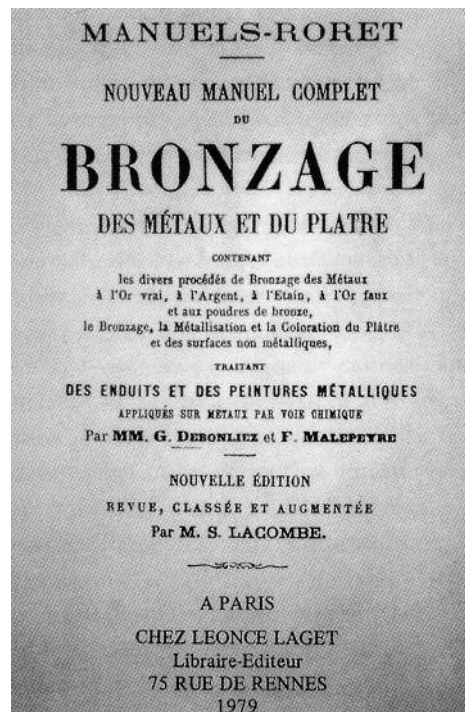

with faux-bronze decorating techniques for metal, plaster, and wood.<sup>4</sup> The forward includes a detailed and important history of the craft (Debonliez and Malepeyre 1887:1–2):

Bronzing, which forms today one of the bronze manufacturing branches, . . . has only existed as a specialty for forty years, and was not as widespread then as it is today. . . . Up until 1825 only one tint of bronzing was known, which was *vert antique* or *vert à l'eau* [author's translation: sea green], which . . . sought to imitate, as closely as possible, bronze exposed to corrosion of the weather . . . or again like Florentine bronzes, in which the color was altered by time or interior vapors.

The authors then relate a succession of vogues for chemical patination colors for bronze that followed each other rapidly. These include one they called a “brown green. . . . [T]his color was made more or less green or brown according to the desires of the worker.” Other stylish colors are said to be “Lafleur’s Florentine bronze, a fumed Florentine tint, of a softer and more elegant color.” Then an *artistic verte* predominated, the color of pale green ashes, followed by *bronze medaille*, a later greenish color with yellowish highlights. Still later, blacks with more-or-less reddish highlights were favored, using bronze powder in spirit varnish, followed by a surface dusting of a soft greenish bronze powder that gave the look of the iridescent throat of pigeon.

Work done in blacks and browns then became popular, also a color called *bronzed iron*, which consisted of a black foundation relieved with pewter powder in imitation of the armor of warriors. The authors describe others including a so-called *waxed bronze*, a *leather bronze*, and a *fly-wing bronze*. This last had a black base with highlights of copper powder, with rosy glazes of hematite (Debonliez and Malepeyre 1887:2–5). The descriptions imply that these vogues followed rapidly one after the other, but they may well have overlapped.

They also discuss a method of “bronzing” wood, porcelain, glass, and metal. This consisted of the application of fine bronzing powders of different colors in a 30% solution of an extremely glossy tree resin from an unidentified source, prepared with potassium or potassium silicate (Debonliez and Malepeyre 1887:136):<sup>5</sup>

After the objects are coated with a thin uniform coating of this glassy solution applied with a small brush, the bronzing powder is dispersed on the objects with a sifter. One allows them to dry completely at a medium temperature of light reheated air, and one then removes the bronze powder with a large soft brush which has not been absorbed by the varnish vehicle. The layer of bronze powder adheres tenaciously to the glassy resin, so that it cannot be removed either by washing with alcohol, ether or water. It lends itself to being polished with a burnisher of agate or steel.

It is unfortunate that the description is not more detailed about specific materials.

It is especially important to note that this guidebook documents that the preference of artists and artisans for faux-patination colors apparently changed radically over time in the intense competition among Paris artisans. This poses great difficulty for conservators and curators in deter-



mining exactly what colors were intended and, by extension, what British and American artisans sought to imitate. Problems with accurate color interpretation are compounded by the difficulty of translating the subtlety of color described in published sources and the change over intervening centuries in the meaning of words used to describe colors.

In the earliest published American reference located in this study, James Cutbush wrote in *The American Artist's Manual* (1814:22):

Bronze color, in imitation of the metal, is much used by the colourmen of Paris, who prepare two sorts of it, namely the red bronze and the yellow, or golden. The latter is made solely of the finest and brightest copper dust, the former is prepared of the same material, by adding a small portion of well pulverized red ochre. Both are applied with varnishes, to the outside of substances, as gold leaves are in gilding. But to prevent it from turning green, the bronzed work should, as soon as laid on, be carefully dried over a chafing dish.

By this time, there was a several-centuries-long tradition of varnishing metals with tinted “changeing lackers” (usually based on shellac) and baking them at high temperature, primarily to change their appearance to that of a more noble metal. Cutbush’s methods clearly derive from this tradition.

An important London book, Nathaniel Whittock’s *The Decorative Painters’ and Glaziers’ Guide* (1827:57), described a technique for imitating antique verte that is actually a marbling technique using paint to imitate a superb green marble. Traditional techniques are described for creating a figured ground using variegated white and black pigments in oil or distemper, with varied overglazes of Prussian blue, raw sienna, and lead white pigments in oil. Alternate glazes in distemper (animal-glue medium) are described. Both were to be followed by second glazes of whitening ground in milk, and dark veins in Prussian blue.

Whittock’s ensuing discussion of the mineral green pigments then commercially available is important for this study (Whittock 1827:12):

All the mineral greens [verdigris and other copper greens] are worked with great difficulty in oil, as they are not opaque colors, and require to be mixed with white lead to give them body. The minerals in both of these oppose each other, and in a short time destroy the work [i.e., react chemically, darken, discolor, and degrade]. Greens both in oil or water colours are therefore best formed of mixtures of yellow and blue that agree together in their bases [are chemically compatible].

For this reason, we probably cannot expect to identify mineral green pigments in work by experienced artisans.

Pilkington gives a similar set of directions for creating a simple painted imitation of “patina antique” on wood (1856:21). “For bronzing sculptures of wood, plaster figures and C. [etc.] a composition of Yellow Ochre, Prussian Blue, and Lamp Black, dissolved in glue water, is employed.”

The most important and complete American source located to date is *The Painter, Gilder, and Varnisher's Companion* (1836:121), based on earlier London editions. The editor and publisher, William Jackson, in discussing “bronzing,” stated:

Bronzing in wood may be effected by a process of mixing Prussian Blue, Pale Yellow, Raw Umber, Lamp Black, and Pipe Clay ground separately in water on stone and as much of them as will make a good color put into a small vessel three-quarters full of size, not quite so strong as clean size. This mixture is bound to succeed best on using about half as much more pipe clay as any other ingredients, the wood being previously cleaned and smoothed and coated with a mixture of clean size and lamp black, receives a new coat of the above twice successively. Afterwards, the bronze powder is laid on with a pencil [small brush] and the whole is burnished or cleaned anew observing to repair parts injured by this operation. Next, the work must be coated with a thin layer of Castille soap to remove the glare of the burnishing and afterwards rubbed with a soft woolen cloth.

Copal varnish is then to be used as a protective coating. Note the similarity of the pigmented ground coating to gilder's bole, and the use of burnishing to create a smooth, metal-like surface. This set of techniques clearly derives from gilders' traditions.

The author of this text described in detail the making and preparation of gold, copper, and bronze powders. Less familiar to conservators today than these powders is *Aurum Mosaicum* powder. The author states that (1836:75–76):

*Aurum Mosaicum* [mosaic gold] is used for inferior articles; it is prepared in the following manner; a pound of tin is melted in a crucible and a half pound of purified quicksilver [mercury] is added to it. When this mixture is cold it is reduced to a powder and ground with half a pound of sal ammoniac and seven ounces flower of sulphur till the whole is thoroughly mixed, they are then calcined in a matrass [a specially shaped glass reaction vessel of the period for mixing chemicals]; and the sublimation of the other ingredients leaves the tin converted into the *Aurum Mosaicum*, which is found at the bottom of the glass like a mass of bright flaky gold powder.

The above documentary sources are diverse in origin. The increasing frequency of publication of instructions and formulas as the nineteenth century progressed makes it clear that verte antique and faux bronzing in different media gained widespread popularity as a decorative technique for imitating true chemical patination on metals. These formulations and materials appear to derive from at least three well-developed artisan traditions: the metal lacquering trade, with baked-on, tinted varnishes; gilding traditions, which used gesso, pigmented animal glue-based bole, gold and metal powders, and burnishing; and faux graining and marbleizing traditions, with many thin layers of variably pigmented paints and glazes.

---

## Interpretation of Historic Verte Antique Coatings

Curators, conservators, collectors, and students familiar with the materials described here will understand why relatively few original verte antique coatings remain, and even fewer remain in good condition and with a reasonable resemblance to original appearance. Although current interest in the techniques has led to increasing discoveries of extant original materials, such finds are relatively rare, which is a primary reason so little research and only one publication to date have focused on the subject.<sup>6</sup>

The principal cause of degradation of most coatings is the unstable nature of the materials themselves; many are inherently fragile or

chemically unstable, either alone or in interaction with each other. The organic pigments used, such as indigo and yellow lakes, may be inherently fugitive and unstable. Bronze- and copper-based pigments tarnish and darken, even when bound in a pigmented or clear coating. Varnish resin and animal-glue binders darken and become brittle. Also, coatings with an animal-glue binder are especially vulnerable to any exposure to water. These forms of degradation and associated losses are often obscured by old restoration attempts, few of them sensitive to original materials or appearance. Restorers frequently overpainted original gold powders with cheap bronze pigment “radiator paint,” black-pigmented shellac, or applied oil gilding to cover underlying damage to more fragile water-gilded surfaces. As original materials darkened with age, each generation of collectors and restorers assumed ever darkening misconceptions of original intent. They darkened their restoration coatings accordingly—partly to match their mistaken assumptions, partly to help disguise losses and surface defects.

Gaining a better sense of original surface intent requires intensive examination of a variety of decorated surfaces that retain some portion of their original coatings, technical examination to understand the complex materials and layering used by the artisan in each case, and extrapolation from current darkened, degraded surfaces back to probable original appearance. Some educated guesswork is inevitably required in this process.

## Technical Investigations



Figure 2  
One of a pair of tables labeled by Charles Honoré Lannuier, New York, 1805–15 (private collection).

The following case histories will illustrate that the variety of techniques and materials found relate closely to the historical literature cited. Examination and analysis included intensive visual examination; solvent testing; fluorescence and visible-light microscopy of finish samples; use of fluorescent indicator stains, where appropriate; and, in one case, technical pigment identification. No technical testing was carried out to differentiate true gold from copper or tin alloy-based (“bronzing”) metal powder pigments. Spirit varnishes were identified by their characteristic white or off-white autofluorescence and rapid solubility in ethyl alcohol, both in areas on the object itself and in samples on the microscope stage. Many of the resin layers were confirmed with a fluorescent indicator stain. Additional technical analyses to identify specific resins, resin mixtures, or other binders were performed in one case only.

The layering sequences in the following cases are indicated, with “a” as the lowest layer.

### Case 1

A pair of Classical Revival card tables, both with a label of Charles Honoré Lannuier, was selected for examination, as many of the verte antique surfaces appeared to be relatively undisturbed, except for some restoration on the gilding (Fig. 2). The tables were passed down to the descendents of the original owner. The caryatid figures combine water and oil gilding, with verte antique decoration on the claw feet, ankles, and tapering caryatid body.

#### Original verte antique layers

- a. Gesso (rabbit-skin glue based)
- b. Oil-based paints of varying dark green, brown, and black colors, applied simply by padding on irregularly with a textured

- rag. (The texture is plainly visible without magnification. No gold or metal powders were used.)
- c. Natural resin spirit varnish as a sealing coat. (The resin or resin mixture was not identified.)

No further analysis was carried out.

These specific techniques and materials have been found by the author only on this pair of tables by Lannuier, although others may exist.<sup>7</sup>

### Conclusion

Lannuier's relatively simple technique of ragging thinly pigmented varicolored oil paints onto a gesso ground seems to fall into the faux painting tradition best illustrated in Whittock (1827).

### Case 2

A series of finish samples were studied from a Classical Revival sofa with feet carved into dragons' heads, then decorated with verte antique and gilding. Other elements of the sofa include gilt stenciling and carving. Long attributed on the basis of family descent to prominent Providence cabinetmakers Joseph Rawson and Son, its secondary woods, carving, and finish suggest it was more likely to have been made in Philadelphia (ca. 1815–25). The sofa was selected as a superb example of verte antique in apparently original condition, although the surface is markedly darkened. Based on unaided visual inspection, decoration consists of green base paint; gold or bronze powder on protruding highlight portions of the carving; and final transparent, lightly pigmented overglazes. The dragons' mouths and ears are painted red.

#### Original verte antique layers on dragons' heads, based on ultraviolet (UV) microscopy of eight samples

- a. Clear spirit varnish sealer<sup>8</sup>
- b. Spirit varnish-based pigmented coating (blue, yellow, green, umber, deep red)
- c. Spirit varnish size
- d. Scattered, discontinuous gold (or bronze) powders laid directly on the sealer-size. (It was found only on highlight portions of the carvings. In some areas it appears more uniformly dense and very thin with metal flakes closely overlapping, as though the powder had been burnished after application and drying.)
- e. One or two layers of lightly pigmented spirit varnish, tinted with brown, dark red, and black pigments. (It was not analyzed further. The pigmented tinting glazes are discontinuous, with considerable variation in thickness and number of coats from location to location. This probably indicates the artisan was dabbing on variably colored layers of thin varnish-glaze to give a patinated appearance and to tone down the reflectivity of the burnished metal powder.)
- f. Sealer coat of clear resin spirit varnish

#### Layers in a dragon's mouth, based on microscopy of two samples

- a. Clear spirit varnish sealer coat



*Figure 3*  
Pier table attributed to Anthony Quervelle, Philadelphia, ca. 1815–25 (collection of Randall Scrimsher). Verte antique was recreated based on extensive microscopy of samples of remaining original finish on this and the second of the pair at the Winterthur Museum.

- b. Green-pigmented spirit varnish paint
- c. Clear spirit varnish sealer
- d. Deep red-pigmented spirit varnish, with extensive metallic powder mixed randomly throughout the entire thickness of the layer
- e. Clear spirit varnish sealer

### Conclusion

The spirit-soluble resins used in every layer meant that the artisan could work quickly, since each layer dried rapidly. The materials and techniques are quite similar to Philadelphia work of the period analyzed by the author; and the design, carving, and secondary woods strongly suggest it is a Philadelphia-made sofa, despite the attribution to the Rawsons. The use of metal powder mixed with other pigments in the red paint is singular in the author's experience, but may represent a common period technique. It was probably intended to give sparkle and additional golden brilliance. Future researchers should look for its presence in other examples.

### Case 3

A Classical Revival pier table from a private collection was examined and treated by the author (Fig. 3). This elaborately decorated piece is attributed to Quervelle, based on stylistic similarities to labeled and documented examples of his work. The other table of the pair in the collection of the Winterthur Museum has identical decorative motifs.<sup>9</sup>

Before treatment by the author in 1991, the verte antique portions of the dolphin supports and the pilasters generally were extremely dark, with black-pigmented coatings over gilded highlights. Extensive preliminary investigation revealed that the dolphins and leafage had been entirely stripped of original finishes, and only the feet retained their original verte antique decoration essentially intact (Fig. 4).<sup>10</sup> Microscopy of a second series of samples from the feet revealed the strata and character of the original coatings, which compared very closely to samples of undisturbed original finish on the other table.

*Figure 4*

A typical finish sample cross section of original verte antique coatings from a foot of the pier table in Figure 3. The magnification is  $\times 200$  on an ultraviolet microscope. From the bottom up: two-layer base coating of green pigmented paint in natural resin binder; scattered flakes of gold powder directly on the upper paint surface; thick, white-fluorescing midzone, composed of five to seven thin layers of natural resin varnish-glaze, with thin pigmentation on some upper layer boundaries; discontinuous dark pigmented restoration overpaint; and clear shellac coating, fluorescing light orange.

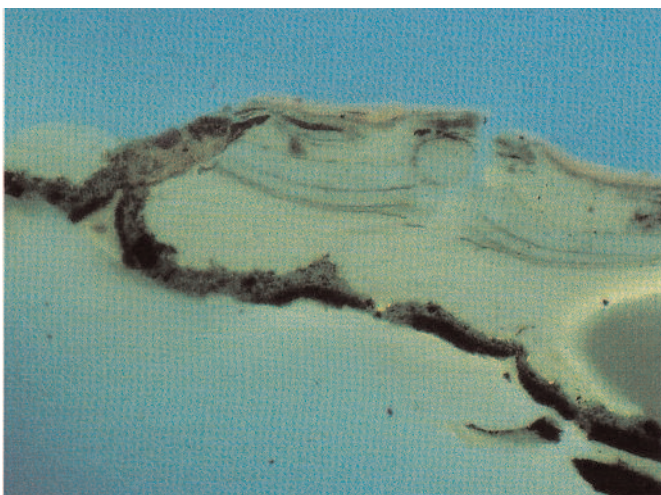

**Original verte antique materials, based on UV microscopy of forty samples**

- a. Two layers of green-pigmented paint in a spirit varnish vehicle. (The darker green bottom layer was applied evenly, and lighter green applied in varying thickness over it.)
- b. Clear spirit varnish size
- c. Gold powder on highlights only. (It was discontinuous and irregular, applied directly to the surface of the underlying spirit varnish. This was not found in recesses or background areas.)
- d. One to five layers of thinly pigmented glaze in a spirit varnish vehicle (dark red, umber, blue, and yellow pigmentation), applied irregularly
- e. Clear spirit varnish sealer

**Conclusion**

The variegated and mottled green base coats with gold powder dusted irregularly on the surface, sometimes burnished on high points to create smoother, glossier gold highlights, would have more accurately simulated natural wear on bronze statuary. This is the most sophisticated and complicated decorative scheme analyzed in the study, but it appears to be typical of Philadelphia work in the exclusive use of spirit-soluble coatings. The actual original appearance of the mottled green base coats was dramatically lighter and more intense in chroma than is visible in the degraded coatings on the other table in the pair.

**Case 4**

Other historical techniques are represented on a Grecian sofa made in New York (ca. 1815–25). It is an example of the finest work of the period, featuring carved paw feet and legs with verte antique decoration, gold stenciling, and water and oil gilding.<sup>11</sup> Examination of the sofa indicated that all gilded and paint-decorated surfaces were covered with a thick layer of restoration bronze-pigmented paint that had discolored and considerably darkened. UV microscopy revealed that original verte antique and gilt layers were surprisingly intact under these restoration coatings.

**Extant original materials**

- a. Gesso, with a protein binder (probably rabbit-skin glue)
- b. Base paint, water soluble, with black and green pigments (probably including considerable clay content)
- c. Gold powder
- d. Clear spirit varnish, probably original

**Conclusion**

The verte antique decoration is simpler than the Quervelle example above. The overall techniques and materials derive from gilders' traditions and are most similar to those described in *The Painter, Gilder, and Varnisher's Companion* (1836), and they are most frequently found in the work of New York artisans.

**Case 5**

Variations on bole-type verte antique are illustrated by a drop-leaf sofa table attributed to Charles Honoré Lannuier, in the collection of the White

House, Washington, D.C. The design incorporates two gilded-winged caryatid supports with verte antique bodies, legs, and paw feet, with scrolled leafage on the legs and gilded monopodium terminals. Examination revealed that all surfaces had extensive restoration painting and gilding with diverse materials that obscured the varied and sophisticated original coatings. Extensive initial microscopy confirmed that the legs and feet had lost most of their original verte antique coatings; however, enough remained to allow accurate characterization of the decoration.

**Original materials, based on UV microscopy of twenty-eight samples**

- a. Gesso, animal glue based
- b. Two to three layers of water-soluble distemper paint (probably with extensive clay inclusions); dark green on the body, black-brown with green on legs and feet. (Colorants on the body identified were indigo, orpiment—a yellow arsenic trisulfide—and possibly a yellow lake. Original surfaces were too damaged to establish whether the surface had originally been burnished.)
- c. Gold powder, sparsely applied
- d. Clear spirit varnish sealer

**Conclusion**

The layers again represent gilders' techniques for creating verte antique through the use of a modified, pigmented gilders' bole and gold powder. Originally, they probably were selectively burnished to further define the surface. Lannuier's use of two different colors of bole (dark green for the body, black for the legs), coupled with traditional water and oil gilding and pierced metal inlay, is reflective of his familiarity with French prototypes.

**Case 6**

A worktable with both a brand and a label of Samuel Carter, New York, in the collection of the White House, represents possibly the simplest verte antique treatment found to date. The overall original surface decoration includes highly refined and developed metal powder stenciling on various surfaces, including the turned central support shaft and colonnettes that support the case top. Original verte antique decoration remains on the legs and carved paw feet.

Examination revealed that considerable flaking and loss of layers had occurred on the legs. To hide the losses, the entire table base had been varnished with a black-pigmented coating, probably shellac. Although not totally opaque, the coating largely obscured the delicate stenciling and faux-bronze decoration.

**Original materials, based on UV microscopy of ten samples and on solvent tests**

- a. Clear spirit varnish (not covering all surfaces)
- b. Green paint in a spirit varnish medium
- c. Clear spirit varnish sealer. (This layer is uneven and does not cover all areas of the green base paint.)
- d. Gold powder applied sparsely and unevenly only on the highlights of the legs, feet, and claws
- e. Thinly pigmented spirit varnish glaze
- f. Clear spirit varnish sealer

Gilded stenciled areas were created with similar materials, except that the green underpaint was omitted, and two to three different colored metal powders were used to create depth and a modeled definition of the pattern.

### Conclusion

This example, the latest in origin of all the pieces examined, suggests that by 1830 artisans in New York had simplified verte antique techniques and materials to permit economy of production.

---

## Conclusion

Interest in connoisseurship, documentary history, and intensive technical study of verte antique is a relatively recent trend. The historical sources and the cited case studies clearly indicate that verte antique, or *bronzage*, is not one technique or set of materials but derives from many different artisans' traditions. It differed widely among artisans and regions, often involving a complex buildup of many layers of different materials. This complexity is further compounded by later restorations, as most original verte antique decorative surfaces have restoration overpaints or coatings (Fig. 5).

Conservators, curators, and collectors will understand that we have achieved merely an initial understanding of the variety of historic verte antique techniques. Tremendous variations in techniques and materials seem to have been the rule. Each case presents a new discovery of technique or material, or a variation on those already known; therefore, each must be studied in depth before conservation treatment can begin. It is hoped that this study will form a brief framework for examining other examples of verte antique decoration, and that it will be expanded and deepened by future researchers in order to broaden our understanding of these stunning historical decorative techniques.

---

## Acknowledgments

Generous help in researching this study was extended by John Driggers of Robert Mussey Associates, and also by Christine Thomson, Susan Buck, Cynthia Moyer, Gregory Landrey, Deborah Bigelow, Betty Monkman, Bill

Figure 5

A cross section from a Classical Revival card table with a carved and verte antique decorated eagle base. Attributed to Charleston, South Carolina, ca. 1820–30 (Collection of Randall Scrimsher). In this sample, original coatings include, from the bottom up, yellowish grain filler/ground coat, composed of a drying oil with coarsely ground silica sand; thin layer of natural resin varnish-sealer with light bluish white fluorescence; green paint, composed of yellow, blue, and dark red pigments in a natural resin vehicle; two-zone layer of natural resin varnish size, again fluorescing bluish white, with gold powder in the center. Later restoration coatings follow: extremely thick coating of bronze pigment overpaint; two-zone layer of green paint.

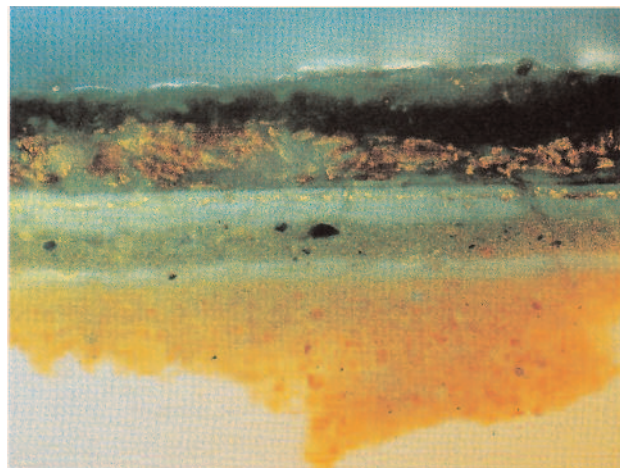



Allman, Michael Flanigan, Randall Scrimsher, Brian Considine, Alfonso Narvaez, Stuart Feld, and Wendy Cooper. Librarians at the following institutions gave invaluable assistance: the Fine Arts Library at Harvard University; the Dibner Library of the Smithsonian Institution; and the Rare Books and Manuscripts Library at the Winterthur Museum.

---

## Notes

- 1 While Pilkington refers to a chemical patination produced by natural processes, his imitative techniques employed pigments, varnishes, and metal powders.
- 2 There is extensive but scattered literature on Lannuier. An upcoming (1998) exhibition and catalogue at the Metropolitan Museum of Art in New York will focus on this important craftsman.
- 3 Quervelle's work is summarized in Smith (1973; 1974a; 1974b).
- 4 Augmented editions were also published, including the 1887 edition cited here. (The author's translations of this text are used throughout.) A reprint of this title was published by Leonce Laget (Paris) in 1979.
- 5 "M. Bottger" is said to be the authors' source.
- 6 There is only one recent publication in the conservation or art historical literature (Loescher 1994).
- 7 The author has examined approximately three dozen pieces to date.
- 8 Most spirit varnish recipes of the period called for a mixture of spirit-soluble resins, including shellac in various forms, copal, dammar, mastic, animé, and sandarac. The term *spirit varnish* is used in this generic sense (a resin mixture), without further attempt to identify the specific resin or resins used. For a complex history of spirit varnish formulations, see Mussey 1987.
- 9 The author extends special thanks to the owner, Randall Scrimsher, and to Michael Flanigan. Gregory Landrey of the Winterthur Museum generously shared his insights and written report on microscopic examination of the museum table and provided finish samples for further microscopy by the author. Both tables are illustrated in Cooper (1993:150–51).
- 10 During examination, a scrap of newspaper with the date 1973 was found hidden on the rear of one leaf bracket. Restoration was probably done just prior to the table's publication on the cover of the magazine *Antiques* May 1973, 103(5).
- 11 This sofa is in the collection of the Baltimore Museum of Art (Acc. #BMA 1991.147), and is illustrated and discussed in Cooper (1993:124–25). It was examined and conserved by Christine Thomson and Susan Buck at the Society for the Preservation of New England Antiquities, Waltham, Massachusetts. Comments in the text are based on their generous sharing of records.

---

## References

- Cooper, W. A.  
1993 *Classical Taste in America, 1800–1840*. New York: Baltimore Museum of Art and Abbeville Press.
- Cutbush, J.  
1814 *The American Artist's Manual*. Philadelphia: Johnson and Warner.
- Debonliez, G., and F. Malepeyre  
1887 *Nouveau manuel complet du bronzage des métaux et du plâtre*. Paris: Roret, 1837. Reprint, Paris: M. S. Lacombe.
- Garrett, Wendell  
1992 Letter to author, 22 October.
- Loescher, Wolfgang  
1994 Über eine besondere Fassungstechnik—Die Imitation von painierten Bronzebeschlagen an Sesseln des 19. Jahrhunderts. *Restauro* 3:340–43.

- Mussey, R. D., Jr., ed.  
 1987 *The First American Furniture Finisher's Manual*. Originally published as *The Cabinetmaker's Guide*, Concord, N.H.: Jacob B. Moore, 1827. Reprint, with a new Introduction and Glossary of Terms, New York: Dover Publications.
- Mussey, R., and A. Haley  
 1984 John Cogswell and Boston bombé furniture: 35 years of revolution in politics and design. *American Furniture* (2):73–105.
- Painter, Gilder, and Varnisher's Companion, The*  
 1836 New York: William Jackson.
- Pilkington, J.  
 1856 *The Artist's Guide and Mechanic's Own Book*. A.V. Blake: n.p., 1841. Reprint, Boston: Sanborn, Carter and Bazin.
- Roubo, André Jacob  
 1977 *L'art du menuisier ébeniste*. Vol 3. 1769–75. Reprint, Paris: Leonce Laget.
- Smith, R. C.  
 1973 The furniture of Anthony G. Quervelle: The pier tables. *Antiques* 103(5):984–94.  
 1974a The furniture of Anthony G. Quervelle: The pedestal tables. *Antiques* 104(1):90–99.  
 1974b The furniture of Anthony G. Quervelle: The worktables. *Antiques* 104(2):260–68.
- Talbot, P.  
 1974 The furniture industry in Boston, 1810–1835. Ph.D. diss., University of Delaware.
- Watin, J. F.  
 1776 *L'art du peintre, doreur et vernisseur*. Paris: Durand.
- Whittock, N.  
 1827 *The Decorative Painters' and Glaziers' Guide*. London: Isaac Taylor Hinton.

# An Investigation of the Nature of Paint on Wood Objects in the Indigenous Southwest of North America

Nancy N. Odegaard

THE SOUTHWEST OF NORTH AMERICA is a region of great environmental diversity and vast distances. In general terms, its boundaries approximate the present-day states of Arizona and New Mexico in the United States, and Sonora and Chihuahua in Mexico. Environmental variability produced varying cultural responses, and the diverse forms of material culture associated with a great number of cultural subdivisions are representative of cultural adaptations to particular geographic features and ecologies found within the region. A critical environmental characteristic is precipitation, which comes mostly in the later summer months. The brief but intense thunderstorms and heavy runoffs of water are vital to life in this region. A cultural concern with water that is bound to the origin, history, and future of the people is also reflected in the raw materials and technologies used in painted wood objects.

Anthropologically, this part of the continent is well known. There are both an extensive archaeological record of the inhabitants that predates the time of European contact in the sixteenth century (Fig. 1) and an equally rich ethnological knowledge of the distinctive cultures

Figure 1  
Prehistoric cultures and archaeological sites where specimens of painted wood have been recovered in the Southwest.

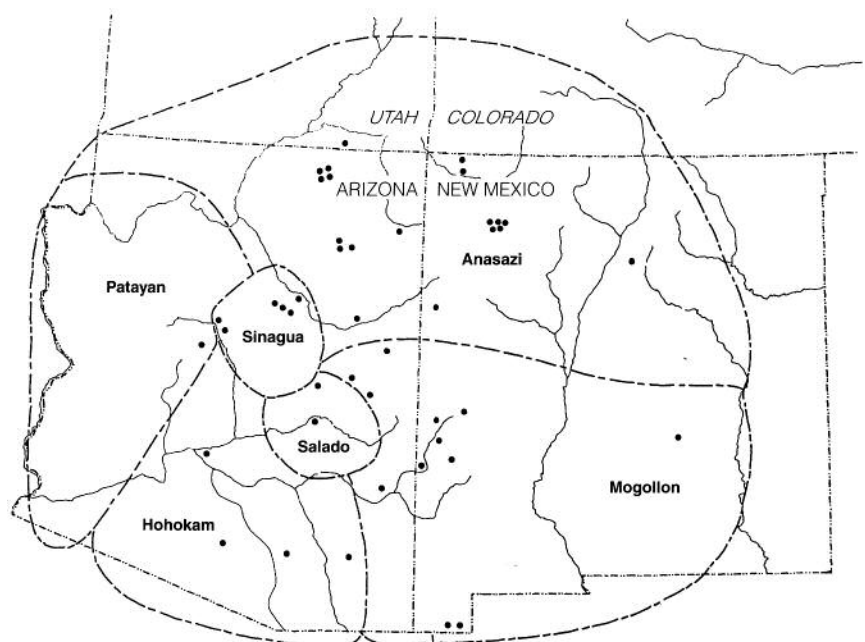

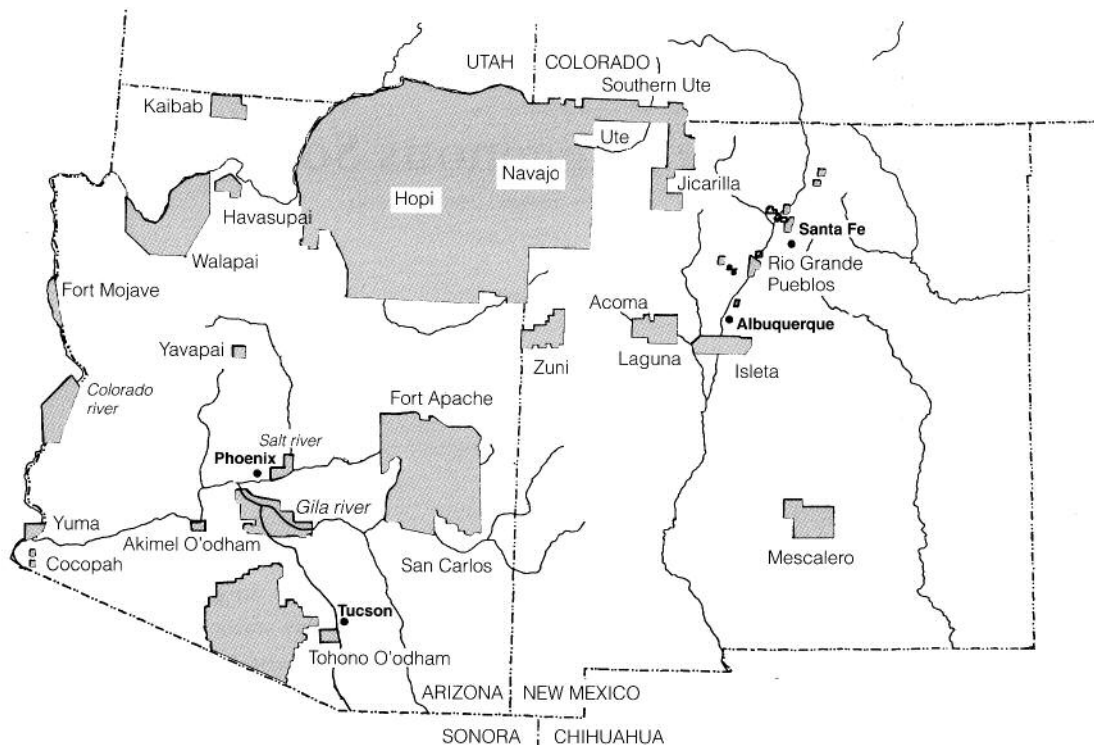

Figure 2  
Indian reservations and villages of the  
Southwest.

that survived through Euro-American contact times to the present (Fig. 2). Comprehensive conservation studies of material culture from the Southwest region generally require the consideration of both archaeology and ethnology regardless of the designation or provenance of the object.

## A Tradition of Painting

Evidence exists for a long-standing and highly skilled tradition of paint making in the Southwest. Archaeologists have recovered quantities of prepared mineral pigment and have observed paint associated with surface decoration on rock art, ceramics, textiles, basketry, and wood. However, much of the processing and application technology for early paint remains unknown. The typical tools recovered for paint grinding or mixing include stone palettes, mortars, mullers, and other flat grinding stones, in addition to pebbles, sticks, and pieces of actual mineral pigment. While any flat-surfaced stone may have been used as a palette, formal studies focusing on the ground stone artifacts related to pigment/paint manufacture from this region are relatively recent and few in number. Such studies may clarify pigment processing and binder and vehicle technologies, in addition to expanding further on our knowledge of paint application methods.

Preservation of a wide range of organic artifact materials is possible in the Southwest because of the extreme aridity found in dry caves and rock shelters. Organic-based prehistoric artifacts, such as painted wood, fall under a material class often referred to as *perishables* by archaeologists. Examples of preserved organic remains in the region date from around 9000 B.C.E. onward. Numerous complete and fragmentary examples of painted wood objects have been systematically recovered from archaeological sites throughout the Southwest region. Also obtained through archaeology are organic-based tools used in applying paint, including dauber fragments of textile and fur, twisted grass and yucca or agave leaf brushes, and worked sticks. In general, however, archaeologists working in

the Southwest have not carried out extensive studies of organic materials because of inadequate recovery tools, techniques, and conservation expertise that would prevent object loss during the excavation process.

---

## Cultural Issues and Ethics

When considering the nature of paints, it is clear that the relationship between any surface coating and its substrate is extremely important. Obviously, the physical requirements of paint that is formulated for application to wood is different from that for other substrates, such as rock, animal skin, or ceramic. Conservators should remember that while the use of certain pigments and binders may be associated with a culture, they may or may not be associated with use on wood. Trader Mark Bahti (1993) has observed that there seems to be a cultural logic in indigenous painting that follows a “like with like” in the manufacture of objects. From this perspective, an animal-based binder media would not harmonize with a wood substrate.

There are also cultural differences in the method of paint application, the way in which the paint cures, the preparation of the substrate, and the conditions of object use. For example, Hartman Lomawaima (1994), a Hopi scholar, has noted that some Pueblo objects are specifically painted more carefully, using finer materials and techniques, and that these objects are given special care that ensures their preservation. For this reason, many religious objects are said to remain in “perfect” condition after several centuries of use.

Another consideration is that some objects that are made to be “used up” do not share these same permanent paint characteristics. For instance, gifts such as kachina dolls given to Pueblo children are traditionally used in play and therefore experience a use wear that is foreseen and expected. The loss of the paint may even hold spiritual meaning; for example, the flaking of blue paint in some cultures symbolized the falling of rain (Lomawaima 1994). In earlier times, it was not uncommon for such items to be collected and repainted after they had worn out or been discarded (Sekaquaptewa 1993). Also, kachina dolls and other painted gifts of the Kachinas may be taken from a child secretly, freshened up, and then returned. This process helps remind the child that the Kachinas are always with them (Lomawaima 1994).

There are meanings and restricted uses for the natural materials that make up cultural objects; these differ depending on the context in a particular culture or in a particular activity. In the manufacture of painted wood objects, there are many examples where the artist’s ability or memory, convenience, and materials at hand have resulted in aspects of technological change (Dockstader 1985). It would seem that cultural traditions may be respected and at the same time be flexible.

With greater attention from scientific investigators and collectors around the turn of the century, Indian groups in the Southwest were encouraged to increase the quantity and change the quality of their manufactures. Many ethnologists requested that legitimate duplicates or replicas be made of worn-out, obsolete, or unavailable specimen types; this practice created objects that were not made for their original purpose. Instead, more emphasis was placed on aesthetic appeal and salability (Dockstader 1985). Today, the creation of many forms of painted wood specifically for commercial use allows many Native American men and women to make a living.

## A Continuous Record of Painted Wood

An argument for continuity of a painted wood tradition in the Southwest is supported by discussion of painted wood objects in archaeological reports, by references to painting in the early Spanish documents of the seventeenth and eighteenth centuries, and by Euro-American ethnographic studies made since the late nineteenth century. Parallels between precontact trade traditions and the oral histories of various indigenous groups have also been used to propose links of common history and common material culture between the prehistoric and historic peoples of the region. Evidence for a record of continuous use of paint on dance and ceremonial masks, prayer sticks, and altar paraphernalia exists throughout much of this region.

Most of the archaeological examples of painted wood in museum collections are fragmentary and require extensive comparative studies to adequately classify form and function. Some of the earliest examples of painted wood objects include miniature bows and arrows, painted wood tablets, baskets, flutes, reed dice, carvings, and bull-roarers. Slender painted sticks (sometimes called *pahos*), in particular, are fairly common in Southwestern sites. Composite forms, such as wooden staffs, bird shapes, terraced objects, wands, and flowers are later examples, but references to them exist widely in both the archaeological and ethnographic records. A survey of ethnological painted wood object types includes drums, sticks, wands, bull-roarers, kachina dolls, masks, baskets, figures, noisemakers, headdresses, gaming pieces, violins, flutes, and bows and arrows.

There are a number of similarities and differences in painted wood technology in the various culture areas defined within the Southwest region. The following review summarizes the consistencies and variability. The greatest number of archaeological painted wood specimens comes from the Mogollon culture area. Most of the preserved specimens have been recovered from dry caves found along the mountainous drainages of the Gila River and its tributaries in southeastern Arizona and southwestern New Mexico. The artifacts are typically constructed of thin laths cut and smoothed from the dry bloom stalk of agave, yucca, or sotol plants (Fig. 3). Examples of Mogollon painted wood generally postdate 700 c.e. The flat laths may be modified with cut holes or slots, notches, or tapers and may be decorated on one or both sides. Composite objects are usually constructed of laths stitched together with sinew or fiber to form terraced objects, flowers, feathers, or bird wings. Masked human effigy forms are also reported. The use of adhesives and binders such as mesquite gum and an unidentified reddish pitch has been reported with specimen descriptions (Cosgrove 1947:24, 2; Wasley 1962; Hough 1914).

Since the 1500s, the prehistoric Mogollon region has been the home of the Chiricahua, Western, and Mescalero Apache peoples of the Athapaskan language family. Traditional Apache objects of painted wood include basketry, puberty canes, arrows, crown masks, and wands. The upright sections of the crown masks and wands were usually constructed of thin slats of yucca or sotol bloom stalk, secured with fiber ties. A variety of paints and binders were used. Pinyon pitch is reported to have been used along with paint on arrows and in the coating of baskets; the juice from yucca leaves has been used with charcoal, and the juice of roasted agave with red pigment (Opler 1965; Tanner 1982).

Artifacts of painted wood from the Anasazi or Ancestral Pueblo area were often carved and smoothed from thin boards or slabs of soft woods, such as pinyon pine, Douglas-fir, or cottonwood. Reported artifacts

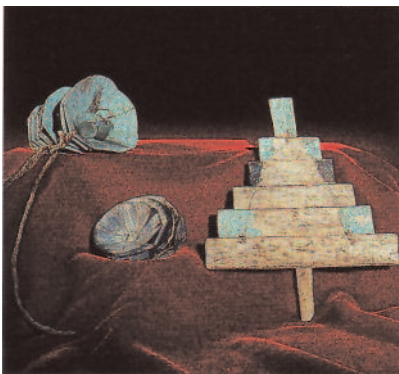

Figure 3  
Painted wood flowers and terraced object  
from the Bonita Creek cave site, Arizona.  
Arizona State Museum.

generally date from the Pueblo III period (1100–1300 c.e.). The flat carved surfaces may be decorated on one or both sides; and effigy forms, including birds, dragonflies, and human faces, are recognizable by the use of paint color and outline. Composite forms are usually joined with fiber ties or sinew. Vivian observes that “the concept of assembling flat carved pieces to produce three-dimensional representations of life forms and other symbols appears to be a successful adjustment to the material, rather than a limitation imposed by it” (Vivian, Dodgen, and Hartman 1978:17). Paints appear to have been primarily applied after construction or assembly of pieces in composite forms. Pinyon pitch and mesquite gum are the reported adhesives; while a range of binder sources has been surmised, only pinyon resin has actually been identified in archaeological materials (Vivian, Dodgen, and Hartman 1978; Kidder and Guernsey 1919; Bandelier 1892).

When the Spanish entered the area of northern Arizona and New Mexico in the sixteenth century, they found farmers who lived in multi-room structures, or pueblos. The Pueblo peoples include the Hopi, Zuni, and Acoma, as well as several groups to the east, often referred to collectively as the Rio Grande Pueblos. Extensive ethnographic, linguistic, and material culture studies have been carried out with these groups since the end of the last century. The tradition of paint on wood is extremely rich among these people. Painted wood objects are represented by many forms, including headdresses, effigies, ceremonial altars, wands, prayer sticks, and dolls. Larger items are usually made of cottonwood root (*Populus fremontii*) or red cedar (*Juniperus communis*), and prayer sticks have been derived from a wide variety of woody plants. Slats may be cut from yucca (*Yucca* sp.) or sotol (*Dasylirion wheeleri*) flower stalk and are often assembled with fiber ties. Many painted wood objects have a white ground layer (kaolin) below the pigmented layer, and the paint has a characteristic matte appearance. The reported adhesive, varnish, and binder media used with painted wood include yucca leaf juice (*Yucca angustissima*), yucca syrup (*Yucca baccata*), pinyon resin (*Pinus edulis*), and masticated seeds (Cucurbitaceae) (Hough 1902; Parsons 1939; Stephen 1898; Stephen 1936; Stevenson 1904; Stevenson 1915).

Few painted wood specimens have been recovered from sites in the Hohokam prehistoric culture area. A notable exception is a group of six wooden artifacts found in central Arizona and believed to date from a Salado occupation before 1400 c.e. (Haury 1945). The well-preserved and nearly complete figures include four effigy *pahos* made of agave stalk and one masked effigy carved of cottonwood. Many archaeologists believe that a tradition of painting on wood among the Hohokam may be inferred because of the abundant amount of pigments and palettes recovered (Haury 1976).

The Tohono O’Odham and Akimal O’Odham presently inhabit the lower desert area of the Southwest region. Painted wood traditions include basketry, bows and arrows, masks, bull-roarers, calendar sticks, effigies, wands, prayer sticks, and bowls. Reported wood sources include saguaro ribs (*Carnegiea gigantea*), gourd (Cucurbitaceae), pine (*Pinus* spp.), ocotillo (*Fouquieria splendens*), and greasewood (*Sarcobatus vermiculatus*). The adhesives and binders traditionally used include mesquite gum (*Prosopis juliflora*) and an insect lac (*Tachardiella larrea*) that is found on the creosote bush (*Larrea tridentata*) (Castetter and Underhill 1935; Ebling 1986; Lumholtz 1976; Sutton 1990).

Examples of painted wood from the prehistoric Sinagua culture area include carved and painted sticks, thin pieces of shaped wood, and bows and arrows. The reported examples generally date from the Pueblo II period (900–1100 c.e.). The colors and designs appear to be similar to examples from the Gila region of the Mogollon area. Characteristic of some composite forms is the use of dowels for attachments. While an absence of binder use is inferred with some pigments (Barnett 1974), insect lac (*Tachardiella larrea* or *T. fulgens*) is identified with the mixing of pigment (McGregor 1943; Sutton 1990).

Unfortunately, few prehistoric Patayan (or Upland Hakatayan) sites provide information relative to the study of paint on wood. Generally, only pieces of pigment alone or small fragments of decorated wood are reported in the archaeological literature. Likewise, there is equally little documentation for the painted wood manufactures of the Yuman language speakers who currently reside in the delta, river, and upland semidesert areas associated with the Colorado River. Bows, arrows, war clubs, and baskets were the wood objects traditionally painted. Pinyon pitch, mesquite gum, and sunflower seeds are referenced in association with the paint technology of several groups (Kniffen et al. 1935:42; Cushing 1965; Sayles and Sayles 1948).

---

## Pigments and Colorants for Wood

The archaeological and ethnographic literature suggests that until the end of the nineteenth century, most painting done by the indigenous cultures in the Southwest was and is associated with religious ceremony. In many of these cultures, color selection is of critical importance, and its use on objects is guided by specific references to the points of direction. In general, paint appears to be the most important form of surface embellishment used to decorate wood. Parsons (1939) explains that for many Indians there is power in paint and that the use of pigments has the effect of completing or “making sacred.” Some of the more common characteristics of painted surfaces from this region include color areas that tend to be separated by definite lines; colors that are not blended or mixed; and paints that are usually applied in uniform thickness.

It appears that most paints are made with ground inorganic mineral pigments, but may also be used as natural fragments or may be processed into a stick or pebble-like form. Unfortunately, archaeological and ethnographic sources that discuss painted wood objects are rarely based on actual chemical or analytical identification of the pigments. More often, object descriptions include a visual reference to color and presumed pigment identification (Table 1). Further research is required to identify the pigments on specimens and to determine which pigments are ground with specialized tools, which are pulverized and washed with water, and which are soft enough to be used in their natural state.

At times, mixtures of inorganic and organic materials may also be used to produce paint. Some examples include gray-blue—charcoal with white clay; and blue—indigo mixed with a fine-grained sandstone or sandy chalk rock.

---

## Binders

To make paint, some pigments and organic colorants can simply be rubbed down on a grinding stone with a little water. Others require the use of a binding media or nonvolatile film-forming material that will hold



Table 1 Commonly referenced inorganic pigments and organic colorant sources

*Inorganic Pigments*

Color	Source
red	hematite (anhydrous ferric oxide) cinnabar, vermilion (mercuric sulfide)
green	malachite (basic copper carbonate) chrysocolla (copper silicate)
blue	azurite (basic copper carbonate)
yellow	limonite (hydrated ferric oxide)
white	kaolin (hydrated alumina silicate) gypsum (calcium sulfate dihydrate) chalk, caliche, whiting, lime (calcium carbonate)
black	magnetite (ferric oxide) pyrolusite (hydrated oxide of manganese) lignite coal
iridescent agents	quartz (silicon dioxide) sphalerite (zinc sulfide) galena (lead sulfide) specular hematite (micaceous iron oxide)

*Common Organic Colorant Sources*

Color	Source
black	charcoal, mesquite bark, corn smut, burnt corn, Rocky Mountain beeweed, coffee
brown	walnut juice, pinyon gum
yellow	flower petals, corn meal, bean meal, cattail, pollen
red	mountain mahogany root, purple corn water with sumac berries and potato clay

the pigment particles together for application as a paint. One of the problems associated with trying to understand the nature of indigenous paint in the Southwest is that, typically, few details about the quality of paint and painting technique are reported. The fact that chemical and analytical identifications of organic binder materials are difficult may partially explain why most archaeologists and ethnologists working in this region over the past hundred years have carried out relatively little analysis of painted wood objects. The terminology used is generally inconsistent and reflects the popular language used at the time a study was made. For example, use of the terms *pitch*, *gum*, *resin*, *rosin*, *sap*, and *lac* are somewhat interchangeable in much of the literature. An understanding of the physical condition of a given painted object is facilitated by a general knowledge of the classification of the binder.

Pinyon exudate is widely reported in the archaeological and ethnographic literature for use as a coating for waterproofing, as an adhesive for mosaic inlay and repairs, as an ingredient in the preparation of certain dyes, and as a binding medium used with pigments for paint. As a binder, pinyon exudate is most commonly referenced with the copper ore pigments. It is usually indicated by a dark brown color and lustrous surface. Though commonly called *pinyon gum*, the exudate is actually a resin (that is, it is insoluble in water and it is capable of melting when heated). Four species of pines may be called *pinyon*. However, most commonly, the

resin is obtained at the natural wounds in the *Pinus edulis* tree, where it appears as a white, opaque, sticky, crystalline mass or as darker pelletlike drippings exuding from the wounds. The exudate or resin consists of volatile oils (sesquiterpenes) and rosin (solid material). The tree grows at intermediate elevations of 1800–2100 m.

The traditional use of pinyon is noted by numerous ethnologists. A process for using pinyon with pigment at Hopi has been described by Stephen (1936:1191–93).

The piñon gum is gathered from the woods, and heated on a fire. Water is added and the mixture stirred as it comes to a boil. After the gum has melted and boiled for eight minutes it is poured over a sieve. Horse tail hair lays over the sieve (prior to horsehair, sheep's wool was used and prior to that fine yucca fiber was used). The gum strains through the hair and coagulates in the water below. Pieces of green copper carbonate are beaten and rubbed with a rubbing stone into a pulp. Some gum/water is added and mixed together. The liquid is sponged up and pressed out in a small basin. The stiff but pliable gum is kneaded between the hands like stiff putty, it is pulled and twisted and pulled until it becomes a soft glistening whiteness. It is dipped into the gum water and then placed in a new pot of water over a fire. As the water heats, the gum softens and melts. The ground pigmented pulp is added before the water boils. The mixture is stirred as it comes to a boil. The longer the mixture boils the darker and thicker the sediment gets. After cooking, the jar is removed from the fire, the water is poured off and fresh water is poured in to cool the pulp/sediment. Working the hands in cold water, a cake is formed.

Also useful from the perspective of cultural context, is Stephen's note (1936) that it would be evil to use a substance that had been boiled for prayer sticks, indicating that this paint would not be used for this purpose.

Another important tree exudate is mesquite gum, which has been reported as a media binder and adhesive in the archaeological and ethnographic literature. As a binder it is most often associated with a black paint obtained by processing the gum with pieces of bark and sometimes with iron oxide. Mesquite gum is the neutral salt of a complex acidic polysaccharide exudate collected from wounds in the trunk of the mesquite tree (*Prosopis juliflora*), which is a leguminous shrub that grows at elevations below 1200 m. The lumps of clear secretion are gathered and dried. The gum characteristically dissolves slowly in warm water to form a viscous solution, and with heat it chars and decomposes without melting. The preparation of black paint from mesquite involves peeling slivers of gum-saturated bark from the trunk of the tree and boiling them in water until thickened. The black paint may be applied alone or mixed with iron oxide (Teiwes 1988; Lumholtz 1976).

The use of masticated seeds, primarily from the Cucurbitaceae (squash) family, in paint production has been observed and reported by several archaeologists and ethnologists working with the Pueblo cultures in northern Arizona and New Mexico (Bourke 1884; Parsons 1939; Smith 1952; Stephen 1936; Whiting 1939). The use of seeds as a paint binder in the Southwest has not been studied extensively; however, based on existing information, it can be suggested that the oily substance from seeds (such as squash, pumpkin, melon, sunflower, cotton, pinyon, cottonwood) mixed with saliva could be applied as paint on a range of artifacts.

Stephen's (1936) description of several processes of squash seed preparation indicates that after a small number of seeds have been chewed and then spat into a shallow metate, some pigment is rubbed down, then a little water is added to make a paint. When discussing the mixture of bright blue copper carbonate with squash seeds, it was observed that if too many squash seeds were used, the pigment became too dark; if none were used, it became drab or off-color. Smith (1952:31) quotes a Hopi who said that "saliva arising from seed-chewing causes the pigments mixed with it to adhere to the painted object and this practice has the purport of a votive offering."

Yucca extracts are referred to widely in the ethnographic literature as a source for binding media, varnish, or adhesive (Bunzel 1932; Opler 1965; Robbins, Peabody, and Freire-Marreco 1916; Tschopik 1941). These media produce a glossy effect and may originate from a syrup prepared from the fruit of *Yucca baccata*, a juice from the leaves of *Yucca glauca*, or possibly from a soapy extract in the roots. The juice that pools in the agave plant, after the leaves are removed to expose the heart, is very potent and could possibly be a binding material (Madsen 1994). Various yucca plants grow throughout the region at a wide range of elevations, from sea level to more than 2400 m.

In her study at Zuni, Stevenson (1904) reported the use of a paste made by mixing water (that had yucca syrup added) with pigments ground in stone mortars. Yucca syrup was made from the fruit and involved a lengthy process of chewing the fruit, cooking it without water, forming and working the mass into pats, and storing until firm (Stevenson 1915).

Honey and lac are insect-based substances sometimes linked with indigenous paint technology. A clear reddish secretion of insects (*Tachardiella larrea*) that infest the creosote plant (*Larrea tridentata*) is reported as an adhesive and in a mixture with specular iron pigment (McGregor 1943; Sutton 1990). The sticky material is collected when the insects encrust the stems in compact masses. The use of honey is also mentioned as a fixative with pigments (Parsons 1939) and as a possible binder (Bahti 1993; Lomawaima 1994; Tenakhongva 1993).

The use of animal-based binding media in the Southwest is mentioned in the ethnographic literature, but primarily in reference to body paint or to coloring on hide-based articles. Deer grease, mutton fat, human mother's milk, cow's milk, and eagle eggs are specific examples of ingredients used, but they are normally not referenced with painted wood artifacts (Bahti 1993; Russell 1975; Spier 1970; White 1932).

---

## Impact of Trade and Euro-American Contact

During the period of Spanish influence, 1540–1848, many new dyes, tools, and ideas were introduced in the Southwest. Trade invoices of the 1600s record the importation of indigo dye from Mexico (Kent 1982), and pigment analysis of several churches in the Southwest indicate the use of nonindigenous paints, such as vermilion and Prussian blue (Gettens and Turner 1951). By 1880, the Denver and Rio Grande and the Atchison, Topeka, and Santa Fe Railroads had entered the Southwest, and commercial paints and aniline dyes were becoming available to indigenous peoples (Kent 1982). By the turn of this century, many explorers, ethnologists, archaeologists, religious missionaries, and government agents had made ink, bluing, watercolors, tempera paints, and house paints available to the

Figure 4  
Hopi kachina dolls representing an evolution  
of form in the twentieth century. Arizona  
State Museum.



Indian people. New tools, such as hammers, axes, and knives, were given to parents in exchange for government school attendance by Indian children (Kent 1982). An interest by many established East Coast museums also stimulated a demand for more artifacts.

The Indian Arts and Crafts Movement, or “Santa Fe Movement,” of the 1920s and the Museum of Northern Arizona Craftsman Shows that began in 1930 encouraged a commercial market for Indian artisans and established an increase in public awareness and in the quality in the crafts (Dunn 1968; Colton 1938). Within the twentieth century, commercialization has taken some painted wood objects from their original cultural context and reclassified them as tourist souvenirs, then as crafts, and finally as fine art sculpture (Fig. 4).

---

## Conclusion

While archaeological reports and ethnological accounts of cultural materials in the Southwest provide valuable insights into the particular preparations and uses of paints, these reports make it equally apparent that efforts to technologically improve their suitability or durability may have resulted in a fairly wide range of paint system developments and refinements. The conservation of indigenous objects of painted wood is not straightforward. This is due, in large part, to a traditional lack of communication in the Southwest between archaeologists or ethnographers and the conservation field, an absence of Native American involvement in the discussion of preservation, and a record of inappropriate conservation measures. Sensitivity to the nature and the importance of issues of cultural context clarifies some of the limitations, reliability, and biases of the reported information. However, an understanding of the nature of paint on wood in the indigenous Southwest requires careful consideration of a wide range of tangible and intangible issues.

---

## Acknowledgment

The author would like to thank R. Gwinn Vivian for his helpful suggestions.

---

## References

- Bahti, Mark**  
1993 Conversation with the author, Bahti Indian Arts, Tucson, Arizona.
- Bandelier, A. F. A.**  
1892 *Final Report of Investigations among the Indians of the Southwestern United States, Carried on Mainly in the Years from 1880 to 1885*. Papers of the Archaeological Institute of America, American Series, vols. 3, 4. Cambridge, Mass.: Harvard University Press.
- Barnett, F.**  
1974 *Excavation of Main Pueblo at Fitzmaurice Ruin*. Special publication. Flagstaff: Museum of Northern Arizona.
- Bourke, J. G.**  
1884 *The Snake-Dance of the Moquis of Arizona*. New York: Charles Scribner's Sons.
- Bunzel, R.**  
1932 Zuni katchinas. In *Bureau of American Ethnology, 47th Annual Report*, 837–1086. Washington, D.C.: Government Printing Office.
- Castetter, E. F., and R. M. Underhill**  
1935 The ethnobiology of the Papago Indians. *University of New Mexico Bulletin, Biological Series* 4(3):275.
- Colton, M. R.**  
1938 The arts and crafts of the Hopi Indians: Their future and the work of the museum for the maintenance of Hopi art. *Museum Notes* 11:3–24.
- Cosgrove, C. B.**  
1947 Caves of the Upper Gila and Hueco areas. In *Papers of the Peabody Museum of American Archaeology and Ethnology, Harvard University*. Vol. 24, no. 2. Cambridge, Mass: Harvard University Press.
- Cushing, F. H.**  
1965 The nation of the willows. *Atlantic Monthly* 50:362–74, 541–59. 1882. Reprint, Flagstaff, Ariz.: Northland Press.
- Dockstader, F. J.**  
1985 *The Kachina and the White Man*. Bloomfield Hills, Mich.: Cranbrook Institute of Science.
- Dunn, D.**  
1968 *American Indian Painting of the Southwest and Plains Areas*. Albuquerque: University of New Mexico Press.
- Ebling, W.**  
1986 *Handbook of Indian Foods and Fibers of Arid America*. Berkeley: University of California Press.
- Gettens, R. J., and E. H. Turner**  
1951 The materials and methods of some religious paintings of early 19th century New Mexico. *El Palacio* 58(1):3–16.
- Haury, E. W.**  
1945 The excavation of Los Muertos and neighboring ruins in the Salt River Valley, Southern Arizona. In *Papers of the Peabody Museum of American Archaeology and Ethnology*. Vol. 24, no. 1. Cambridge, Mass.: Harvard University Press.

- 1976 *The Hohokam, Desert Farmers and Craftsmen: Excavations at Snaketown, 1964–1965*. Tucson: University of Arizona Press.
- Hough, W.**
- 1902 A collection of Hopi ceremonial pigments. In *United States National Museum Annual Report for 1900*, 463–71. Washington, D.C.: Government Printing Office.
- 1914 Culture of the ancient Pueblos of the Upper Gila. In *United States National Museum Bulletin*. Vol. 87. Washington, D.C.: Government Printing Office.
- Kent, K. P.**
- 1982 *Pueblo Indian Textiles*. Santa Fe: School of American Research.
- Kidder, A. V., and S. J. Guernsey**
- 1919 Archaeological explorations in northeastern Arizona. In *Bureau of American Ethnology Bulletin*. Vol. 65. Washington, D.C.: Government Printing Office.
- Kniffen, F., G. MacGregor, R. McKennan, S. Mekeel, and M. Mook**
- 1935 Walapai ethnography. In *Memoirs of the American Anthropological Association*. Vol. 42, ed. A. L. Kroeber. Menasha, Wis.: American Anthropological Association.
- Lomawaima, H.**
- 1994 Conversation with the author, Arizona State Museum, Tucson.
- Lumholtz, C.**
- 1976 *New Trails in Mexico*. New York: Charles Scribner's Sons, 1912. Reprint, Tucson: University of Arizona Press.
- Madsen, J.**
- 1994 Interview with the author, Arizona State Museum, Tucson.
- McGregor, J. C.**
- 1943 Burial of an Early American magician. *Proceedings of the American Philosophical Society* 86(2):270–98.
- Opler, M. E.**
- 1965 *An Apache Life-Way*. Chicago: University of Chicago Press, 1941. Reprint, Cooper Square Publications, New York.
- Parsons, E. C.**
- 1939 *Pueblo Indian Religion*. 2 vols. Chicago: University of Chicago Press.
- Robbins, W. W., H. S. Peabody, and B. Freire-Marreco**
- 1916 Ethnobotany of the Tewa Indians. In *Bulletin of the Bureau of American Ethnology*. Vol. 55. Washington, D.C.: Government Printing Office.
- Russell, F.**
- 1975 *The Pima Indians*. Reprint, with Introduction, Citation Sources, and Bibliography by B. L. Fontana. Tucson: University of Arizona Press.
- Sayles, G., and T. Sayles**
- 1948 The pottery of Ida Redbird. *Arizona Highways* (January):28–31.
- Sekaquaptewa, E.**
- 1993 Kachinas vs. kachina dolls: The significance of Kachinas in Hopi religion. Notes from a lecture presented to the Arizona Archaeological and Historical Society.
- Smith, W.**
- 1952 Kiva mural decorations at Awatovi and Kawaika-a with a survey of other wall paintings in the Pueblo Southwest. In *Papers of the Peabody Museum of American Archaeology and Ethnology*. Vol. 37. Cambridge, Mass.: Harvard University Press.

- Spier, L.  
1970 *Yuman Tribes of the Gila River*. Chicago: University of Chicago Press, 1933. Reprint, New York: Cooper Square Press.
- Stephen, A. M.  
1898 Pigments in ceremonials of the Hopi. *Archives of the International Folk-Lore Association* 1:260–65.  
1936 *Hopi Journal of Alexander M. Stephen*. Ed. E. C. Parsons. Columbia University Contributions to Anthropology. Vol. 23. New York: Columbia University Press.
- Stevenson, M. C.  
1904 The Zuni Indians: Their mythology, esoteric fraternities and ceremonies. In *Bureau of American Ethnology, 23rd Annual Report*, 1–608. Washington, D.C.: Government Printing Office.  
1915 Ethnobotany of the Zuni Indians. In *30th Annual Report of the Bureau of American Ethnology for the Years 1908–09*, 31–102. Washington, D.C.: Government Printing Office.
- Sutton, M. Q.  
1990 Notes on creosote lac scale insect resin as a mastic and sealant in the Southwestern Great Basin. *Journal of California and Great Basin Anthropology* 12(2):262–68.
- Tanner, C. L.  
1982 *Apache Indian Baskets*. Tucson: University of Arizona Press.
- Teiwes, H.  
1988 The art of Rupert Angea, contemporary Papago potter. *Masterkey* 62(1):3–11.
- Tenakhongva, C.  
1993 Interview with the author, Arizona State Museum, Tucson.
- Tschopik, H.  
1941 Navaho pottery making. In *Papers of the Peabody Museum of American Archaeology and Ethnology*. Vol. 17, no. 1. Cambridge, Mass.: Harvard University Press.
- Vivian, R. G., D. N. Dodgen, and G. H. Hartman  
1978 Wooden ritual artifacts from Chaco Canyon, New Mexico: The Chetro Ketl collection. In *Anthropological Papers of the University of Arizona*. Vol. 32. Tucson: University of Arizona Press.
- Wasley, W. W.  
1962 A ceremonial cave on Bonita Creek, Arizona. *American Antiquity* 27(3):380–94.
- White, L. A.  
1932 The Acoma Indians. In *47th Annual Report of the Bureau of American Ethnology for the Years 1929–30*, 17–192. Washington, D.C.: Government Printing Office.
- Whiting, A. F.  
1939 Ethnobotany of the Hopi. *Museum of Northern Arizona Bulletin* 15.

# The Painted Furniture and Wooden Decorative Arts of Lucia and Arthur Mathews

Mark A. Harpainter and Christopher C. Augerson

**I**MAGINE THE CREATIVE ENERGY required to rebuild a large metropolis from scratch. Following the disaster of the earthquake and fire of 1906 in San Francisco, which virtually leveled the city, this monumental task confronted its citizens.

As a leader in the civic arts community, Arthur Mathews applied himself to facilitating the reconstruction of the city according to the high artistic and aesthetic standards of the prevailing Arts and Crafts movement. Arthur and his wife, Lucia, founded the small Philopolis Press and used its periodical, *Philopolis* (love of the city), to disseminate these ideas. With partner John Zeile, they established a shop to construct furniture for homes and businesses destroyed by the quake, manifesting their ideals of interior design and incorporating their artistic training and talents. Following the evolution of the furniture and decorative arts created in this shop and the Mathewses' elevation of applied arts to fine art status, we see the emergence of a new and unique expression of the Arts and Crafts movement, referred to as the "California Decorative Style" (Jones 1985:32).

Born in a family of talented architects in Wisconsin, Arthur Mathews distinguished himself in his teens by winning national architectural competitions while still an apprentice in his father's San Francisco architectural firm. Turning from architecture to fine arts, he became an illustrator and, at age twenty-five, entered the Académie Julian in Paris for formal training, where he received the Grand Gold Medal for distinction. The artistic environment in Paris offered him influences ranging from new trends in French Neoclassical art, as practiced by muralist Puvis de Chavannes, to Japanese woodblock prints with their flat color planes and different use of perspective. Arthur returned to San Francisco in 1889 and taught art at the California School of Design, where he soon became director.

Lucia Kleinhans Mathews, a native of San Francisco, attended the city's public schools, which, at that time in California, "were strongly committed to manual arts education, teaching students the principal tenets of the Arts and Crafts movement, particularly the belief that the union of hand, head and heart in handicraft yielded therapeutic value" (Trapp 1993:9). After briefly attending Mills College, she enrolled at the Mark Hopkins Institute of Art. Her artistic talents rapidly won her recognition, not only in the school, but with her instructor Arthur Mathews. She married Arthur in 1894 and traveled with him to Europe in 1899, studying painting in Paris under James McNeill Whistler at his Académie-Carmen.



On returning to California the Mathewses resumed working, Arthur as a prominent muralist and Lucia as a painter, as they developed their artistic partnership. Arthur was concerned with the structured compositional aspects of architecture, Classical motifs, and mural painting. Lucia, after exposure to his teaching, adopted these and various Parisian influences, to form her own distinct and personal artistic identity. Her technique evolved as a looser, more “painterly” style, eventually gravitating to a preference for the immediacy and spontaneity of watercolor in the early 1900s (Jones 1985:79).

---

## The Furniture Shop

Perhaps if the great earthquake had not occurred, the abrupt change in the Mathewses’ artistic careers to making furniture might never have happened. The pivotal disaster provided an immediate need and market, and their friendship with the wealthy art enthusiast John Zeile provided the site, capital, and business expertise for the new venture. Arthur Mathews designed a craftsman-style brown-shingle building to house studios for himself and the artist William Keith, as well as separate shops for Zeile’s Beach Robinson Furniture Company and the Mathewses’ own Furniture Shop.

The new workshops were set up to produce limited-production, custom-designed furniture. They were equipped with electric machinery (Giberti 1980:19), and it is estimated that thirty to fifty employees worked on some architectural interior projects, although regular employees were fewer in number (Jones 1985:83).

The division of labor in the Furniture Shop between Arthur and Lucia likely resulted from their respective training. Arthur generally employed skills he gained as an architectural draftsman to design the main structural forms. Lucia was usually in charge of carving and executing the painted decoration. Although she often did the carving herself, particularly on the more decorative pieces, she had assistant wood-carvers working with her. These carvers were usually European trained and frequently had to be retrained to properly execute the low-relief carving favored by the Mathewses (Jones 1985:88). Such low-relief decoration was used essentially as embellishment; it seldom modified the basic form. Lucia also created many of the tabletop pieces, sometimes made as gifts for friends or family, and she continued to produce such personalized works after the closure of the Furniture Shop in 1920. Some of these objects bear her signature.

Patrons of the Furniture Shop included both private and corporate clients. Due to a need for immediate replacement of furnishings after the quake, corporations such as insurance companies and banks became the Furniture Shop’s first clients. For these institutions, the Furniture Shop produced suites of furniture in sober styles sympathetic to the business-oriented architectural surroundings of their clients. On seeing the work the Mathewses did for corporations, individuals who were rebuilding their residences in the city became the private clientele of the Furniture Shop. Such clients were probably exposed to the Mathewses’ furniture in offices and boardrooms, but often the connections may have been social. Many businessmen would have been acquainted with Arthur Mathews and John Zeile through private organizations. Arthur was a member of the Bohemian Club, and Zeile was a member of the Pacific Union Club (Giberti 1980:25–26).

The early furniture was simple, strongly constructed, and minimally decorated—if at all—usually with carving. Like those who acquired

them, the pieces were conservative in style. As principal designer, Arthur used a vocabulary for this furniture that drew on well-accepted classical prototypes (e.g., klismos chairs for Pacific Title Insurance) and English Baroque forms (e.g., William and Mary chairs for the First National Bank), as well as American Empire styles (Giberti 1980:28).

With the transition from corporate to private clientele, the furniture evolved from heavier Renaissance forms to a more eclectic style. The pieces began to incorporate elements from Neoclassical, Asian, Gothic, and contemporary European styles, while employing a more creative use of carving and paint. Some pieces exhibit a clear influence from Chinese furniture, and perhaps the shallow relief carving the Mathews favored was informed by similar carving on Chinese furniture. San Francisco's Chinatown in 1909, rebuilt after the earthquake, contained "the most magnificent Oriental bazaars in the Occidental world" (Steele 1909:96), full of inspiration for a furniture maker. Little of the Mathews' work has survived, and the primary record of it is in an original catalogue of photographs—referred to as the "Furniture Shop sample book"—which is now in the collection of the Oakland Museum.

---

## Furniture as Artwork

True to the aspirations of William Morris, the Furniture Shop produced not only "workaday" tables and chairs, but also what Morris called "state" furniture, created, he wrote, "as much for beauty's sake as for use: we need not spare ornament on these, but may make them as elegant as we can. . . . [T]hese are the blossoms of the art of furniture" (Anscombe 1991:29). These individual works displayed a more personal involvement by the Mathews and were decorated with careful artistic devotion. Unlike the plainer limited-production furniture they designed, these pieces command individual attention as art objects.

In 1908, the Mathews created an individual and elaborately painted suite of furniture for their partner, John Zeile. Included in this suite were pieces that trace their roots directly to English Arts and Crafts works and their English prototypes. A drop-front desk resembles the "Backgammon Players" cabinet made by Morris and Co. in 1861. The Morris piece, like the Mathews', was also designed by an architect (Philip Webb), and decorated separately by a painter (Edward Burne-Jones). The Mathews rearranged the form to create a writing desk, and extensively carved and decorated the surface. Incorporating a miniature of Arthur's full-size painting *The Wave* in the interior, the desk acts, in a sense, as a frame for the painting.

Part of the same suite for Zeile, a chest or sideboard (Fig. 1), is reminiscent of Burne-Jones's 1860 painted cabinet, "Good and Bad Animals," now in the Victoria and Albert Museum. Similar in form, both works use painted decoration of romantic figurative scenes on the primary surfaces.

A later drop-front desk by the Mathews (Fig. 2) is of the same form as the one made for Zeile. Like the earlier desk, it traces its roots through Morris to the Gothic form of an English court cupboard. Relying more on color and painted decoration than the exotic veneer on their earlier piece, it covers every visible surface with paint. Decorative devices such as low-relief painted Classical motifs and carved figures on the supports are repeated. The Arcadian scene on the outside face of the drop front is typical of their work.

*Figure 1*

Chest, ca. 1906–20. H:117 cm; W:206 cm; D:66 cm. Pair of cylindrical candlesticks, n.d. H:74 cm; W:18 cm. Jar with lid, ca. 1906–20. H:28 cm; W:28 cm. *Portrait of Lucia K. Mathews*, painting by Arthur Mathews, ca. 1899. H:63.5 cm; W:58.4 cm. The Oakland Museum of California, gift of the Concours d'Antiques, the Art Guild.



## The Harmonious Environment

*Figure 2*

Desk, Arthur and Lucia Mathews, ca. 1910–12. Carved and painted wood. H:150 cm; W:122 cm; D:51 cm. The Oakland Museum of California, gift of Mrs. Margaret R. Kleinhans.

Both Arthur and Lucia were influenced by J. M. Whistler's emphasis on close color harmonies and use of certain dominant hues to unify his compositions. In the Mathewses' works, the warm, atmospheric light of coastal California and its landscape is captured with ochres, golden browns, and greens (Fig. 2). Like Whistler and the artists of the English Aesthetic movement, the Mathewses sought to create complete interiors with unified decorative schemes. As their painted decoration flowed from the canvas onto the frame and finally over the furniture, they dissolved the border between the artwork and the living space or domestic world. Their carved and painted frames coordinate not only with the paintings they contain but also with the surrounding furniture and decorative tabletop items (Figs. 1, 3).

*Figure 3*

*Portrait of Miss Louise Schwamm*, painting by Arthur Mathews, 1899. H:99 cm; W:89 cm. The Oakland Museum of California, gift of the Concours d'Antiques, the Art Guild.



Some Furniture Shop commissions, such as that for the San Francisco Masonic Temple, included complete interiors: furniture and decorative arts in harmony with architectural elements, murals, and rugs, all designed by the Mathewses. Unlike the complete interiors of Frank Lloyd Wright, which incorporated relatively abstract and geometric decoration, the Mathewses' designs appear more "organic," perhaps closer in spirit to the California architects and furniture makers Charles and Henry Greene.

On the West Coast, a primary bond with nature and the influence of Asia set an aesthetic tone for the Arts and Crafts movement. A folding screen decorated by Lucia Mathews, circa 1910–15 (Fig. 4), shows direct observation of nature and inspiration from Japanese decorative work.

With the proliferation of the California bungalow, porches and gardens became an important part of the domestic scene. "Outdoor" rooms served as transitional spaces between the domestic interior and the landscape, while California's mild climate enabled people to spend time outdoors year-round. William Morris had suggested that even small residential city lots could incorporate gardens in their design. As a gardener, Lucia Mathews likely derived as much inspiration from her garden and the coastal landscape as from the floral patterns and decorative designs published widely by Arts and Crafts advocates like Morris. Her painted carvings, like that on the small hexagonal box shown in Figure 5, bring the flora of the California garden onto articles of domestic utility, creating a continuum between indoors and outdoors.

---

## Techniques and Media

To create the rich and colorful decorative effects on their painted furniture, the Mathewses employed a diverse range of traditional paint and finishing media, often using elaborate, complicated, and probably rather experimental techniques. Areas of paint are juxtaposed with areas of gilding, or stained or transparent finishes, and opaque and transparent media are layered and interleaved to achieve subtle tonalities and surface effects.

*Figure 4*

Four-panel screen, Arthur and Lucia Mathews, ca. 1910–15. H:183 cm; W:203 cm. The Oakland Museum of California, gift of the Art Guild.





Figure 5

Hexagonal box, Arthur and Lucia Mathews, n.d. Carved and painted wood. H:28 cm; W:18 cm. The Oakland Museum of California, gift of the Concours d'Antiques, the Art Guild.



Figure 6

Clock, Lucia Mathews, ca. 1906–15. Painted and gilded wood, metal, enameled face, and glass clockwork. H:37.5 cm; W:15.2 cm; D:10.1 cm. The Oakland Museum of California, gift of the Art Guild.

During an NEA-funded conservation project, approximately seventeen of the Mathewses' painted and decorated wood objects in the collection of the Oakland Museum were examined and treated. These ranged from decorated frames for paintings to small decorative art objects to large furniture pieces. Cross-section paint samples were taken from most of the decorative art pieces and examined, using visible-light, fluorescence, and FT-IR microscopy.<sup>1</sup> In general, these microscopic analyses revealed few signs of later alteration or reworking, and it seems that most of the surfaces are likely the work of Lucia Mathews. Staining the samples viewed in ultraviolet light<sup>2</sup> revealed the presence of oil in both paint and varnish layers. Staining for protein showed its presence not only in discrete layers or thinly dispersed between layers but also in some of the oil-containing layers. FT-IR analysis confirmed the presence of some of these media, primarily resin-oil mixtures and protein layers. The resin spectra most closely matched those of copal and sandarac. Other individual components were difficult to identify. Some of the cross-section samples had curious structures (e.g., with different media twisted in and out of adjacent layers; bleeding from one layer to another; or lean oil mixtures over richer ones to produce craquelure).

The two cross sections of finish from the hexagonal box (Fig. 5) revealed up to nine layers of different media. From the lowest layer, these include a ground layer, which tested negative for protein; oil-resin paint and varnish layers; another ground, which tested positive for protein; then another succession of oil-resin paint and varnish layers, some of which contained protein. This suggests a major adjustment or change of the artist's mind, as none of the layers seemed separated by a clear layer of dirt or use. Unfortunately, the sampling was limited by budget and time constraints. More sampling and analysis is clearly needed to unravel such complicated and idiosyncratic surface structures, but a general pattern of painterly approach and experimentation in the decoration of the surfaces seems clear.

Perhaps the most interesting and challenging phenomenon found on the Mathewses' painted works is the wide variety of darkening and crazing or craquelure from varnishes and glazes, which reveals a probable intent in creating the aged and timeworn effects and tonalities these artists valued. These cracked surfaces range from transparent amber or yellow varnish with very slight crazing to dark molasses-colored finishes that have pulled up into discrete islands on the surface of the paint layer—with many shades and variations in between. These surfaces are particularly visible on many of the smaller decorative objects, such as the jar shown in Figure 1 and the clock in Figure 6. The painted decoration of one jar was almost completely obscured by darkened varnish. Difficult decisions were faced as to how the jar might be returned to exhibitable condition without intruding into what seemed to be an original, or at least not fully understood, surface structure. It was decided that microabrasives under magnification would be used to reduce the varnish. This allowed the underlying painted scene to be read without altering the varnish craquelure pattern. Microabrasives were also used for a pair of urns, on areas of varnish that previously had been damaged by water. All other treatments of the Oakland Museum pieces involved only simple surface cleaning and the filling and inpainting of losses, using standard techniques and materials.<sup>3</sup>

Considering the wide variety of influences Arthur and Lucia Mathews combined in creating their furniture, it is interesting and thought provoking to speculate on just what the rich surfaces looked like when these artists stood back to admire their work as it dried (or cracked!). Today, we can only speculate as to their artistic intent. Exactly how much of the mellowed surface patina and tone is the result of their hand, and how much has time contributed to it? A local newspaper critic (Garnett 1912:35) visited the Furniture Shop one September day in 1912 and, after examining a recently completed desk (possibly the one illustrated in Figure 2), provided a unique contemporary perspective of the newly completed work:

A desk was designed by Mr. Mathews and some of the ornamentation is also his work. The piece also contains a number of panels in inlay and carving, the work of Mrs. Mathews. It is, as a whole, and in detail most charming, and has a character that is quite its own. Indeed, the Mathews are producing a type of furniture so distinctive that one can readily imagine the collector of the future classing it as the California School of the early 20th century.

Clearly, the extraordinary collaboration of Arthur and Lucia Mathews imbued their painted furniture with a unique, personal style and vital spirit. The fact that these pieces are true masterpieces of American decorative art was as apparent then as it is now.

---

## Acknowledgments

The authors wish to thank Harvey Jones, Kenneth Trapp, John Burke, Elisabeth Cornu, and Bonnie Baskin for assistance in preparing this paper.

---

## Notes

- 1 Analytical work was performed by Tracy Power and Christopher Augerson at the M. H. de Young Memorial Museum in San Francisco, California, and by Michele Derrick and John Landrey at the Getty Conservation Institute in Marina del Rey, California.
- 2 For the fluorescence microscopy, fluorochrome Rhodamine B was used to test for oil, and the fluorochrome FT-IC and the stain Amido Black for protein.
- 3 Mechanical abrasion was carried out with fine grit diamond files, followed by Micro-mesh abrasive. Surfaces were cleaned using either saliva or isooctane on cotton swabs. Flaking paint and varnish layers were consolidated with either sturgeon or rabbit-skin glue. Loss compensation was carried out with an epoxy putty or acrylic gesso. Magna acrylics were used for inpainting of paint layers, and Soluvar matte or gloss varnish—sometimes with dry pigments—was used for varnish layers.

---

## Materials and Suppliers

**Magna acrylics**, Bocour Artist Colors, Inc., Garnersville, NY 10923.

**Micro-mesh abrasive**, Micro-Surface Finishing Products, Inc., Box 818, Wilton, IA 52778.

**Soluvar varnish**, Conservation Materials Ltd., 100 Standing Rock Circle, Reno, NV 89511.

---

## References

- Anscome, Isabelle  
1991 *Arts and Crafts Style*. New York: Rizzoli.
- Garnett, Porter  
1912 News of the arts and artists. *San Francisco Call*, 22 September.

- Giberti, Bruno**  
1980 *Rooms for a renaissance: Interior decorations as practiced by Arthur and Lucia Mathews at the Furniture Shop, 1906–1920.* Master's thesis, University of California at Berkeley.
- Jones, Harvey**  
1985 *Mathews, Masterpieces of the California Decorative Style.* New York: Gibbs and Smith and Oakland Museum.
- Steele, Rufus**  
1909 *The City That Is: The Story of the Rebuilding of San Francisco in Three Years.* San Francisco: A. M. Robertson.
- Trapp, Kenneth, ed.**  
1993 Introduction to *The Arts and Crafts Movement in California: Living the Good Life.* New York: Oakland Museum and Abbeville Press.

PART FOUR

# Investigations and Treatment





# Monochromy, Polychromy, and Authenticity

## The Cloisters' *Standing Bishop* Attributed to Tilman Riemenschneider

Michele D. Marincola and Jack Soutanian



Figure 1  
*Standing Bishop*, attributed to Tilman Riemenschneider (ca. 1460–1531). H:117 cm; W:34.3 cm; D:22.8 cm. The Metropolitan Museum of Art, The Cloisters Collection, 1975 (1975.25).

IN 1975, THE POLYCHROME WOOD SCULPTURE *Standing Bishop* was acquired for The Cloisters collection, the Metropolitan Museum of Art, New York. This piece—considered at purchase to be a mature work of Tilman Riemenschneider (ca. 1460–1531), a leading German master of Late Gothic sculpture—was intended to complement early works by the artist already in the collection. The sculpture (Fig. 1) is indisputably in the style of Riemenschneider; furthermore, its provenance (established to before 1907) includes the renowned Munich collection of Julius Böhler.<sup>1</sup> The *Standing Bishop* was accepted as an autograph work by the great Riemenschneider scholar Justus Bier (1956), who was reversing his earlier opinion. It has been compared stylistically to a number of works by Riemenschneider from about 1505–10.

In the 1970s, a research project was begun by art historians and conservators in Germany to establish the chronology and authorship of a group of sculptures thought to be early works of Riemenschneider. The Cloisters' sculptures, including the *Standing Bishop*, were examined as part of the project, and cross sections were sent to Munich for analysis by Hermann Kühn. This research project resulted in an exhibition of the early work of Riemenschneider in Würzburg in 1981; The Cloisters sent two sculptures from its collection, but the loan of the *Standing Bishop* was not requested. Certain stylistic anomalies of the figure, as well as several technical peculiarities discussed below, contributed to the increasing suspicion that it was not of the period. Another cause for concern was that in the nineteenth century the *Standing Bishop* was owned by a Mr. Kahle, a collector and sculptor.<sup>2</sup> By the late 1980s, the sculpture was removed from exhibition at The Cloisters for further study.

---

### Riemenschneider and Monochromy

Tilman Riemenschneider was active in Würzburg as a master sculptor of stone and linden wood from 1485 until the mid-1520s. It is evident from the eclectic style of his early work that he received training in Ulm and had contact with Netherlandish and Upper Rhenish works. He had a large workshop in Würzburg, employing twelve apprentices at the height of his production (Baxandall 1980:259). Riemenschneider is a particularly well-documented sculptor, with a number of commissioned works firmly attributed to him. An early example of a documented shrine is the former high altarpiece for the Saint Maria Magdalena parish church in

Münnerstadt, commissioned in June 1490 and completed by September 1492. This retable is particularly important because it is the earliest example of an altar that was decorated in a monochromatic, as opposed to polychromatic, technique (Staatliche Museen Berlin 1981:117). The recognition of the practice of creating unpolychromed works appears in the art historical literature as early as 1912 (Lossnitzer 1912:139ff.), although the observation of a distinct coating on the wood surface is not published until more than fifty years later, as first reported by Oellermann (1966). The subject has also been taken up, to varying degree, by Wilm (1923:114–18), Lill (1940), Willemsen (1962), Paatz (1963:79–82, 86–93), Taubert (1967), Baxandall (1980:42–48), Melzl and Buchenrieder (1980), Oellermann (1981), Westhoff and Haussmann (1987), Rosenfeld (1990), and Westhoff (1993), among others.

Many of Riemenschneider's early works in wood were decorated in the traditional medieval manner, with lifelike flesh tones, burnished gold robes with matte blue linings, silvered armor, elaborate textile imitations, and other painterly attempts at verisimilitude. Riemenschneider worked with *Fassmaler* (painters), who executed the *Fassung* (painted and gilded decoration) of wood sculptures carved by Riemenschneider and his workshop. With the Münnerstadt altarpiece, however, a radical departure from tradition is encountered: the surface of the pale linden wood is covered not with layers of preparation, metal leaf, and paint but with a thinly applied, transparent, brown-to-black pigmented glaze. Riemenschneider, while continuing to produce polychrome sculpture, created altarpieces using this technique well into the sixteenth century, as did other sculptors working in Germany, including Veit Stoss, Hans Leinberger, Niklaus Weckmann, and Henrik Douvermann. These sculptures, somewhat inaccurately termed *monochromes*,<sup>3</sup> are sometimes further embellished with red for the lips and for wounds, and with black for the eyes; there are also examples where the flesh tones and attributes are painted, leaving the balance of the figure brown (Westhoff and Haussmann 1987; Rosenfeld 1990). Since the sculptor could not rely on painting to convey the rich variation of texture and gloss that was appreciated on medieval sculpture, he often elaborated the surface with a range of knives and punches to create a similar effect. Monochromatic relief sculpture can display a particularly impressive range of surface embellishment in this fashion.

For a number of reasons, the identification of a sculpture as a monochrome is especially complex. The pigmented glaze layer itself, as much a penetrating colorant as a distinct coating, can be difficult to recognize during examination and is usually preserved only in traces. The medieval sculptor's practice of painting the eyes directly on the wood during manufacture (perhaps to set the gaze of the figure or to help position the form during carving) can be mistaken for the finished eyes of a monochrome work. In addition, a transparent surface coating applied directly to the wood may serve as a final, intentional decorative layer, or as a wood sealant for subsequent ground and paint layers. After their creation, monochromes were occasionally brightly overpainted, obscuring the original appearance of the sculpture. The most famous example of such an alteration is the Münnerstadt altarpiece, which was finished and delivered as a monochrome, then redecorated twelve years later with a traditional polychromy by Veit Stoss (Staatliche Museen Berlin 1981:117). This redecoration was later removed from the sculptures, taking with it much of the

monochromy. Sculptures that are sometimes confused with monochromes may actually be polychrome figures that had been stripped with lye, a practice common to the nineteenth century. During an investigation, therefore, it is important to bear in mind that a suspected monochrome may actually be an unfinished sculpture (Rosenfeld 1990), or a work that has lost its original polychromy.

---

## Techniques of Manufacture: The *Standing Bishop* Support



Figure 2  
*Standing Bishop*, back view.

Samples of the wood from the support of the *Standing Bishop* were removed for microscopic identification and radiocarbon dating analysis. The wood was identified as a species of the genus *Tilia*, exhibiting the physical characteristics of limewood, or linden (Quirk 1989). Radiocarbon dating analysis, using accelerator mass spectrometry, gave an adjusted calendar age range for the wood of 1280–1440 C.E., indicating that the tree was felled in the medieval period (Tamers 1989).

Examination of the techniques used to sculpt the figure yielded several interesting observations. Macroscopic and radiographic examination of the *Standing Bishop* revealed that the figure was carved from a single piece of relatively knot-free wood, except the hands and attributes, which were attached separately. The back of the *Standing Bishop* was not hollowed out, as is customary with late medieval wooden figural sculpture, but was flattened with an adze; several practice cuts with a chisel are to be found on the back as well (Fig. 2). Although (to the best of the authors' knowledge) no other Riemenschneider sculptures of this size carved three-quarters in the round were treated in this manner, there are other Late Gothic sculptures of a similar scale with flattened backs (Tångeberg 1989:161). Marks from the sculptor's bench, which held the log in a horizontal position while it was carved, are preserved on the sculpture. A hole (diameter approx. 2.2 cm; depth approx. 3.7 cm), now filled with wood and painted, remains in the top of the miter, where a dowel or pin had held the log fast at one end. Beneath a modern pine base, added to the bottom, are found rectangular impressions from the knives that had secured the log at the other end (Fig. 3). Since they are so close together, it is likely that the impressions in the bottom resulted from separate skewerings in the bench. Although sculptors' benches are thought to have been used in Germany until the early twentieth century, these marks are almost identical to those found on indisputably medieval works of art (von Ullman 1984).

Restorations to the figure include sections of the hands and crozier staff, the sudary (handkerchief held by a bishop), and the plinth. It was also detected that carved decoration is obscured by the thick ground layer; this is noticeable especially at the edge of the cope, where an undulating craquelure has developed that follows the punch work beneath. In addition, the backs of the gloves have been incised with a pattern of overlapping circles (executed with a compass?) surrounded by shallow half-moons. Detailed carving that is covered by subsequent paint layers does not alone provide proof of the sculpture's original monochromy, since *Fassmaler* sometimes obscured or corrected details of carving when they decorated sculptures. Rather, it may be taken in this case as corroborative evidence of a change of appearance for the *Standing Bishop*.

## Polychromy



Figure 3  
Detail of marks that are a result of securing the sculpture in the sculptor's bench, found beneath the modern base.

At first glance, much of the polychromy appears to be medieval. There are traces of several different restoration campaigns on the surface. A fair amount of overpaint is evident on the figure—especially in the hair, gloves, collar, back of the sculpture, and plinth—and probably dates to when the attributes, fingers, and plinth were renewed. The balance of the polychromy—the flesh tones and garments—appears to belong to the same period. The burnished water gilding on the cope exhibits some regilding and a craquelure usually associated with a certain amount of aging; extensive retouching and a developed craquelure pattern are seen in the flesh tones and the cope lining. Many of the surfaces bear fine parallel scratches left from a mechanical removal of overpaint layers. The miter and chasuble were cleaned of their overpaints in this fashion (there are traces of two overpaints on the chasuble) but in such a way as to remove most of the red- and green-glazed silver leaf, revealing the red preparatory bole layer. It appears likely from the exceedingly smooth surface and from faint depressions visible in raking light that this bole layer was later polished, probably with an agate, to give it the appearance of a deliberate decorative layer (Hückel 1978). The flesh tones consist of lead white, with the addition of vermilion and charcoal black, and the alb is decorated with a thin layer of lead white. All pigments were identified with polarized light microscopy (PLM) and confirmed, as necessary, with energy-dispersive X-ray spectrometry.

A closer look at the polychromy, however, reveals several aspects that are inconsistent with an early-sixteenth-century date. The decorative scheme of gold banding on a glazed silver garment is unusual for the period. In addition, the small size and thinness of the gold leaves are more typical of, although not restricted to, a nineteenth-century gilding. A preparatory ground of calcium carbonate in animal glue, executed in at least two layers, extends over the entire sculpture, with the exception of the face and hair. In these areas, the color appears to have been applied directly on the wood. The fringe of the cope is coarsely painted in an alternating pattern of white, red, and blue, the latter two decorated with gold highlights. The red areas are constructed not in the typical multilayer fashion, but in a single layer consisting of a mixture of red lead, red earth pigments, and charcoal. The blue lining of the cope and the fringe (both heavily retouched with artificial ultramarine) was executed in two layers, as was common in medieval practice. The choice of materials, however, indicates a more recent date for the blue: it consists of a coarsely ground layer of azurite, with the addition of dolomite, lead white, and a small amount of barium sulfate (identified by energy-dispersive X-ray spectrometry), supported on a finely ground layer of the same mixture of pigments. Barium sulfate was first proposed as an artists' pigment about 1782 and did not reach widespread commercial application (often as an extender for lead white) until the early nineteenth century (Feller 1986). Its presence on the figure provides a *terminus post quem* for the blue areas, and, since the blue appears contemporary with the balance of the decoration, in all likelihood for the entire polychromy.

Further study of the *Standing Bishop* was carried out in an effort to reconcile the difference between the apparent age of the wood and that of the paint and gilding layers. No trace of earlier polychrome layers was

found below the ground. Excavations made through the flesh tones of the face, however, revealed an additional, intermittent dark layer between the paint and the wood that consists of small black particles (identified by PLM as charcoal) in a brown colored, brittle, water-soluble binder. This layer is found under the ground and directly on the wood in all areas of the sculpture, except the modern replacements. There appears to be a conscious modulation of this layer, with pigment applied more thickly to the fringe and more thinly to flat areas of the sculpture. The eyes, which were partially cleaned of their paint before the figure entered the conservation studio, have the pupils and edges of the irises rendered in black directly on the wood. An excavation in the area of the mouth revealed, under the paint layers, a red glaze that was applied to the wood. Excavations through the paint and ground layers to the wood found wood-boring beetle holes that were filled with ground; the pigmented glaze, however, stopped at the edge of the holes, indicating that the glaze predates not only the infestation but also the polychromy. It appeared from these investigations that the *Standing Bishop* was originally a monochrome.

Cross sections of the paint layers, together with the wood, were taken from several areas for further characterization of the pigmented glaze. No trace of a dirt or dust layer was found beneath the glaze, indicating that it was applied shortly after the figure was carved. A cross section from the area of the mouth (Fig. 4) shows quite clearly the red pigment (a red lake, probably madder lake) and its binder penetrating the pores of the wood support. On top of this layer are occasional particles of charcoal that are separated from the subsequent overpaint by a very thin, brightly fluorescing layer. This intermittent coat of black pigment corresponds to the layer found directly on the wood over the balance of the figure.

Initial inquiries into the binding medium of the pigmented glaze were made. Media analysis is particularly difficult in this case due to the microscopic remains of the layer, interference from the wood, and contamination from the overlaying ground layers and consolidation treatments. Infrared or amino-acid analysis, therefore, was not attempted. For the present study, the placement of the binding medium into one (or more) of three broad categories of material was made using ultraviolet microscopy in conjunction with fluorescent stains. The stains were applied to the cross sections with felt-tip markers that had been loaded with a

*Figure 4*  
Microphotograph of a cross section from the bottom lip of the *Standing Bishop*: (1) the wood substrate, (2) the red lake glaze, (3) the glaze pigmented with charcoal, and (4) the pink overpaint. Normal light,  $\times 40$ .

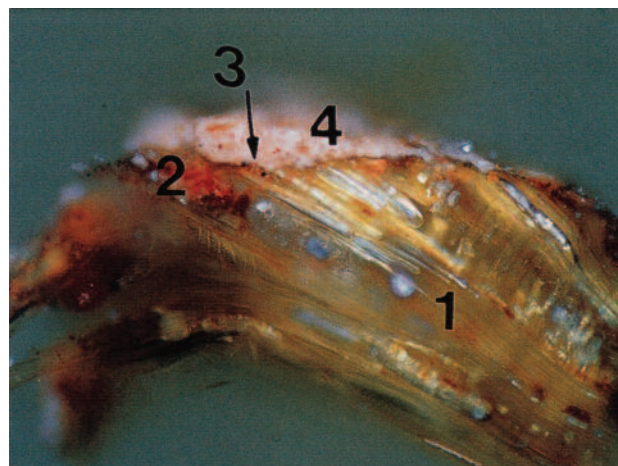

specific fluorochrome,<sup>4</sup> and the sections were examined under high magnification in ultraviolet light. Staining of cross sections with triphenyltetrazolium chloride (TTC) (4% in methanol) for carbohydrates gave a positive reaction in the region of the pigmented glaze (Fig. 5). The application of fluorescein isothiocyanate (FITC) (0.25% in acetone) for proteins produced a positive reaction above the glaze, as well as in discrete portions of the layer that correspond to cracks in the glaze. The fluorochrome Rhodamine B (0.25% in ethanol) for drying oils gave negative results in the glaze but reacted quite positively for some of the later polychromy. The absorption of TTC in the pigmented glaze, indicating the presence of carbohydrates, points perhaps to the use of polysaccharide gums, applied alone or in conjunction with a plasticizer such as honey. The use of fruit-tree gums for painting on wood is mentioned by Theophilus in the twelfth-century treatise *Schedula diversarum artium* as a rapidly drying alternative to oil colors (Hawthorne and Smith 1963:32–33); these gums were especially used in tempera systems on account of their emulsion-building properties, and can be combined with linseed oil, balsams, egg, or casein. Gums increase the adhesion of paint films to hygroscopic substrates and impart an enamel-like gloss to the paint surface (Schramm and Hering 1988:124–26). With the knowledge that the glaze layer on the *Standing Bishop* appears to contain carbohydrates, a possible avenue for further characterization might be simple-sugar ratio analysis.<sup>5</sup>

---

## Comparative Material

Several autograph works by Riemenschneider have been examined in the course of conservation treatments for traces of their original surface decoration. The results have been published and will only be summarized here as they compare with the findings for The Cloisters' *Standing Bishop*.

Individual sculptures belonging to the Műnnerstadt altarpiece were investigated in 1977–78 and traces of a pigmented surface coating were found on many of them (Fig. 5). This layer is described as consisting of a protein (animal glue) and a tiny amount of oil-binding black particles (charcoal), red or yellow oxides, and occasionally lead white. The eyes (irises, pupils, folds of the eyes, and eyebrows) are rendered in black, and the mouths in red, directly on the wood; pigmented glaze is found over these areas. The pigmented material has penetrated deeply into the pores

Figure 5

Microphotograph of a cross section from a fold in the chasuble, stained with triphenyltetrazolium chloride (TTC) and fluorescein isothiocyanate (FITC): (1) the wood substrate; (2) the glaze pigmented with charcoal, exhibiting a positive reaction for carbohydrates; (3) a separation layer between the glaze and the later ground, exhibiting a positive reaction for proteins; and (4) the ground layer. UV light, blue-violet filter,  $\times 1,132$ .

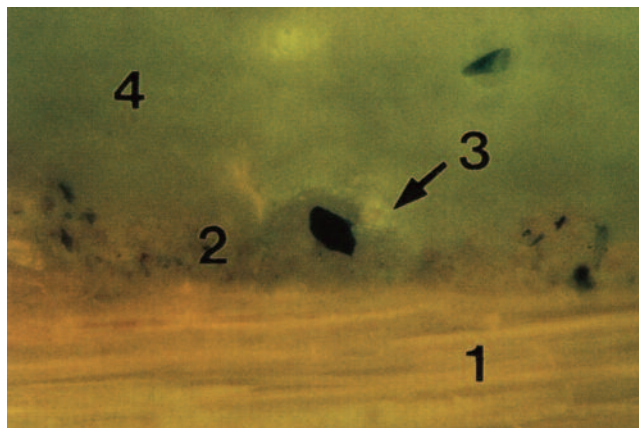

of the wood and exhibits few characteristics of a discrete layer (Staatliche Museen Berlin 1981:318).

The *Altar of the Holy Blood*, commissioned by the city of Rothenburg for the church of Saint Jakob in 1501 and delivered in installments until 1505, underwent a technical examination in the early 1960s. Both the linden wood figures and the shrine and foliate ornaments carved from spruce were coated with a pigmented glaze composed of egg white and oils (egg tempera?) with the addition of ochre, charcoal, gypsum, and lead white (perhaps as a dryer). This glaze was found directly on the wood, and also under the painted eyes and lips, as on *The Cloisters' Standing Bishop* and the M $\ddot{u}$ nnerstadt altarpiece. As with these works, no trace of a dirt or dust layer was found beneath the pigmented glaze, and later restorations bear no sign of the coating, indicating that it must have been applied shortly after the sculpting of the figures (Oellermann 1966).

Similar coatings have been identified on other works by Riemenschneider, including the Crucifix from Saint Nickolaus in Eisingen (Melzl and Buchenrieder 1980), the altarpieces of the *Coronation of the Virgin* in Saint Jakob, Rothenburg ob der Tauber (Melzl and Buchenrieder 1980), and the *Crucifixion* in Dettwang (Oellermann 1966).

An interesting comparison can be drawn between *The Cloisters' Standing Bishop* and the figure of Saint Mary Magdalen from a crucifixion scene made in 1509–16 for the Zweifalten cloister and recently attributed to Niklaus Weckmann the Elder. Under a later polychromy from 1624, a layer of animal glue was found that is *not* pigmented; small losses at the drapery borders, however, reveal a transparent glaze containing pigment particles (Westhoff and Haussmann 1987). This seems to be an attempt to contrast the cooler toned borders with the balance of the draperies and calls to mind the *Standing Bishop*, which appears to have a deliberately strengthened application of its pigmented glaze in the fringe.

---

## Conclusion

The presence of a transparent, pigmented glaze applied over painted eyes and lips—which appears, both in terms of material content and application method, to be similar to other coatings found directly on the wood of late-fifteenth- and early-sixteenth-century sculpture—is a strong indication of the original monochrome appearance of the *Standing Bishop*. Both material analysis and tool mark traces suggest the wooden support was felled and carved in the Middle Ages. On the basis of cross-section analysis, the glaze appears to date to the period of the carving, and not to the nineteenth-century polychromy visible today. While the results of this investigation cannot offer proof of authenticity, the presence of a decorative layer not described in the literature until well after the sculpture was known supports a medieval date for the creation of the *Standing Bishop*.

---

## Acknowledgments

The authors would like to thank William D. Wixom; Michel David-Weill, chairman of the Department of Medieval Art; and The Cloisters, the Metropolitan Museum of Art, for permission to publish this sculpture. Thanks also to Bodo Buczynski, chief conservator at the Staatliche Museen Preussischer Kulturbesitz Berlin, for reviewing the paper and making several helpful suggestions. The authors are grateful, as well, to Mark Wypyski, associate research scientist at the Sherman Fairchild Center for Objects Conservation, the Metropolitan Museum of Art, who

performed the energy-dispersive X-ray spectrometric analysis. Thanks also to Christopher McGlinchey, associate research chemist in the Sherman Fairchild Paintings Conservation Center, the Metropolitan Museum of Art; and Richard Wolbers, associate professor of Paintings Conservation, University of Delaware/Winterthur Art Conservation Program, for their assistance with cross-section analysis. Also, thanks to Hiltrud Jehle, conservator at the Staatliche Museen Preussischer Kulturbesitz Berlin; and Erwin Emmerling, conservator at the Bayerisches Landesamt für Denkmalpflege, for assistance with references.

---

## Notes

- 1 The Cloisters, the Metropolitan Museum of Art, department file no. 1975.25, catalog card 3.
- 2 See note 1.
- 3 This term is currently undergoing discussion in Germany; for purposes of convenience, the English word *monochrome* shall here designate nonpolychromed sculpture.
- 4 The authors are indebted to Richard Wolbers, associate professor of Paintings Conservation, Winterthur/University of Delaware Program in Art Conservation, for supplying the markers.
- 5 The authors are grateful to Richard Newman, research scientist, Department of Objects Conservation and Scientific Research, Museum of Fine Arts, Boston, for this suggestion.

---

## References

- Baxandall, M.  
1980 *The Limewood Sculptors of Renaissance Germany*. New Haven and London: Yale University Press.
- Bier, J.  
1956 St. Andrew in the work of Tilman Riemenschneider. *The Art Bulletin* 38(December):215–23.
- Feller, R. L.  
1986 Barium sulfate—natural and synthetic. In *Artists' Pigments: A Handbook of their History and Characteristics*, vol. 1, ed. R. L. Feller, 47–64. Cambridge: Cambridge University Press; Washington, D.C.: National Gallery of Art.
- Hawthorne, J. G., and C. S. Smith  
1963 *On Divers Arts: The Treatise of Theophilus*. Chicago: University of Chicago Press.
- Hückel, A.  
1978 Forschung zum Frühwerk Tilman Riemenschneiders. Examination report, The Cloisters, New York.
- Lill, G.  
1940 Die Moosburger Reliefs von Hans Leinberger nach ihrer Konservierung. *Pantheon* (25):190–94.
- Lossnitzer, M.  
1912 *Veit Stoss: Die Herkunft seiner Kunst, seine Werke, und sein Leben*. Leipzig: Verlag Julius Zeitler.
- Melzl, E., and F. Buchenrieder  
1980 Der Eisinger Kruzifixus von Tilman Riemenschneider. *Jahrbuch der Bayerischen Denkmalpflege* 34:89–110.
- Oellermann, E.  
1966 Die Restaurierung des Heilig-Blut-Altars von Tilman Riemenschneider. *Bericht des Bayerischen Landesamts für Denkmalpflege* 24(1965):75–85.



- 1981 Erkenntnisse zur ursprünglichen Oberflächengestalt des Münnerstädter Magdalenen-Altars: Möglichkeiten einer Rekonstruktion. In *Tilman Riemenschneider—Frühe Werke*, ed. Staatliche Museen Preussischer Kulturbesitz Berlin, 318–21. Regensburg, Germany: Mainfränkischer Museum Würzburg.
- Paatz, W.**  
1963 *Süddeutsche Schnitzaltäre der Spätgotik*. Heidelberg, Germany: Carl Winters, Universitätsverlag.
- Quirk, J. T.**  
1989 Report of wood analysis, dept. file no. 1975.25. The Cloisters, New York.
- Rosenfeld, J.**  
1990 *Die nichtpolychromierte Retabelskulptur als bildreformerisches Phänomen im ausgehenden Mittelalter und in den beginnenden Neuzeit*. Hamburg: Verlag an der Lottbek.
- Schramm, H. P., and B. Hering**  
1988 *Historische Malmaterialien und ihre Identifizierung*. Graz, Austria: Akademische Druck- und Verlagsanstalt.
- Staatliche Museen Preussischer Kulturbesitz Berlin**  
1981 *Tilman Riemenschneider—Frühe Werke*. Regensburg, Germany: Mainfränkischer Museum Würzburg.
- Tamers, M.**  
1989 Report of carbon-14 analysis, dept. file no. 1975.25. The Cloisters, New York.
- Tängeberg, P.**  
1989 *Holzskulptur und Altarschrein: Studien zu Form, Material und Technik; Mittelalterliche Plastik in Schweden*. Munich: Callwey.
- Taubert, J.**  
1967 Zur Oberflächengestalt der sog. ungefassten spätgotischen Holzplastik. *Städel-Jahrbuch* (NF 1):119–39.
- von Ulmann, A.**  
1984 *Bildhaurertechnik des Spätmittelalters und der Frührenaissance*. Darmstadt, Germany: Wissenschaftliche Buchgesellschaft.
- Westhoff, H.**  
1993 Holzlichtige Skulptur aus der Werkstatt des Niklaus Weckmann. In *Meisterwerke Massenhaft: Die Bildhauerwerkstatt des Niklaus Weckmann und die Malerei in Ulm um 1500*, 135–45. Ulm, Germany: Süddeutsche Verlagsgesellschaft.
- Westhoff, H., and B. Haussmann**  
1987 Zweifalten und Alpirsbach—zwei monochrome Altäre? *Zeitschrift für Kunsttechnologie und Konservierung* 1(10):125–30.
- Willemsen, E.**  
1962 Beobachtungen zur Oberflächenstruktur niederrheinischen Skulpturen. *Jahrbuch der Rheinischen Denkmalpflege* (24):189–97.
- Wilm, H.**  
1923 *Die Gotische Holzfigur*. Leipzig: Verlag Klinkhardt and Biermann.

# Conservation of the Fourteenth-Century Ceiling at Saint Helen's Church, Abingdon

*Anna C. Hulbert*

**T**HE TOWN OF ABINGDON is on the river Thames near Oxford. It has been a prosperous town since the early Middle Ages; its abbey, of which little survives, was founded in the late seventh century. Saint Helen's parish church may be the one mentioned in late-tenth-century records, but the present five-aisled building dates mainly from the thirteenth to sixteenth centuries. The Lady Chapel was founded in the mid-thirteenth century by William le Reeve, whose name was later recorded on its ceiling. The chapel is situated at the east end of the inner north aisle of the church, adjacent to the chancel. Its ceiling originally had thirteen pairs of figures on each side (i.e., a total of fifty-two), sloping up to a flat soffit 1.32 m (4 ft. 4 in.) wide. Around the cornice, at purlin level, a hymn to the Virgin Mary is painted in black letter script, with an inscription recording the chapel's benefactors, notably William Cholsey (d. 1373), who paid for the roof. Also present on the inscription is an indulgence granted by Pope Boniface IX in 1391; this suggests that the ceiling may date from the last decade of the fourteenth century.<sup>1</sup> Borenus (1936), Preston (1936), and Liversidge (1965) discuss the history at greater length; it is sufficient here to add that close examination while the ceiling was dismantled refutes Tristram's suggestion (1955:64) that the inscription was added later. The costumes of many of the kings of the House of David, with their broadly splayed cuffs and pointed shoes, are in accord with a date in the 1390s. (English panel paintings of the fourteenth century are fairly rare. This author has recently cleaned the rood screen at All Saints' Church, Clifton, Bedfordshire, where two female saints have similar splayed cuffs.)

The figures depicted are the ancestors of Christ listed in Matthew 1:6–16 (Table 1). On the south side, the sequence began with a giant recumbent figure of Jesse, and continued with the kings of Judah up to the Babylonian captivity. Each king is paired with an Old Testament prophet bearing an inscribed scroll; most of these Latin texts and juxtapositions of figures have subtle theological significance. (Several of these texts continue in use as Advent antiphons in our own time.) On the north side, the series continues with the great spiritual ancestor Moses (unlike the kings, the prophets are not in chronological order) and leads to Saint Joseph, from the New Testament, and the Annunciation group (Fig. 1). The archangel Gabriel is the only figure wearing a gold-embroidered

Table 1 Figure panels on the ceiling of Saint Helen's Church, Abingdon

Pairs on south side	Pairs on north side
1. Jesse* and David**	1. Moses and Josiah
2. Nathan (with Jesse's legs) and Solomon**	2. Jeremiah and Jeconiah
3. Ahijah and Roboam**	3. Zephania and Salathiel
4. Prophet** and Abijah**	4. Obadiah and Zorobabel
5. Prophet** and Asa	5. Haggai and Eliakim**
6. Baruch and Josaphat	6. Habakkuk and Zadok
7. Amos(?)** and Jehoram	7. Jonah and Eleazar
8. Elijah and Uzziah	8. Zechariah and Mathan
9. Patriarch Jacob and Joatham	9. Malachi and unidentified king
10. Hosea** and Achaz	10. Joel and unidentified king
11. Nahum and Hezekiah	11. Isaiah and King Jacob (?)
12. Micah** and Manasses**	12. Saint Joseph and archangel Gabriel
13. Prophet** and Amon**	13. Lily Crucifix and the Virgin Mary

\* fragment

\*\*missing



Figure 1  
Saint Joseph, the archangel Gabriel, the Lily Crucifix, and the Virgin Mary; panels from the east end of the north side of the Lady Chapel ceiling, conservation nearly complete.

garment. Unfortunately, the figure of Mary is badly damaged after six hundred years adjacent to a damp exterior wall at the east end of the chapel. Between them, Christ is shown crucified on the lily, which is his mother's emblem; this seems to have been a peculiarly English devotional subject.<sup>2</sup> Here, the combination of the Lily Crucifix with the Jesse Tree gives a special meaning to the prophecy in Isaiah 11:1: "Et egredietur virga de radice Iesse, et flos de radice eius ascendit." Only in Latin is the "rod that shall come forth from the stem of Jesse" clearly referred to as a flower. This is extensively discussed by Watson (1934).

One of the most interesting features of this Jesse Tree is the careful characterization of the individual kings. In every case in which the Bible gives information about a monarch's life, the artist has taken pains to portray his personality and has succeeded with remarkable vividness. It should be remembered that the Bible had recently been translated into English by the reformer John Wyclif (d. 1384) and his circle, and it had not yet come to be regarded as seriously heretical to study it in English. This master painter might, therefore, have had an unprecedented opportunity to read it himself. Below the figures, their names were painted on a series of horizontal boards at wall-plate level. Three godly kings—Asa, Josaphat, and Hezekiah—have square-cut gemstones in their crowns; the rest have varieties of cabochon. Such cutting was a relatively new technique (Campbell 1991:136).

## Technique

The ceiling is constructed of straight-grained, quartersawn oak of prime quality, imported from the Baltic area.<sup>3</sup> The ceiling may, in fact, have been built very slightly later than the aforementioned papal indulgence. The construction is somewhat unusual in that the tracery is built up from sev-

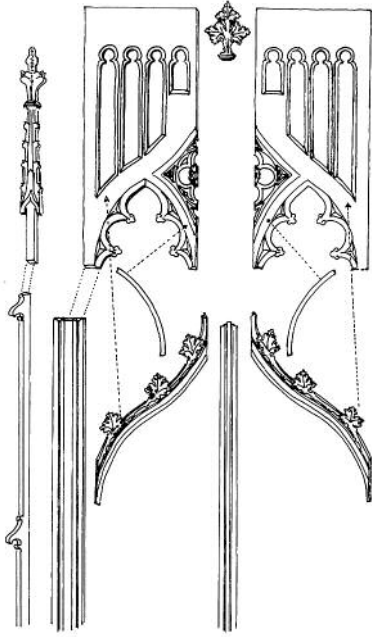

Figure 2

Diagram of the tracery overlay of panels shown in Figure 1, through which the green background may be seen at the top of each panel (compare with Fig. 7).

eral layers of thin planks (Fig. 2). These layers were secured by wooden pegs; but because all the medieval rafters have disappeared, it is not known how the whole ceiling was originally attached to the roof.

The tracery overlay of the soffit forms a lattice pattern with bosses of lion masks and other small foliage designs. Most of these bosses retain some color. The sloping figure panels are framed in pairs under crocketed ogee "canopies": thirteen ogee arches on each side, with finials, and little pinnacles in between. The components retain many incised setting-out (layout) lines. The various parts were numbered, using small punches. These figures represent one of the earliest examples of arabic numerals being used by an English artisan, although some were employed by sculptors at Wells (ca. 1240), which the masons of the time seem to have had difficulty in reading.<sup>4</sup>

The figure panels are, on average, just over 2 m (7 ft.) long, nearly 30 cm (1 ft.) wide, and about 7 mm thick, sometimes less. Some retain distinct marks from the adze used to prepare the surface. The front surface was finished by planing. The panels are numbered in pairs, 1–13, using small punches on the north side (Fig. 3), and cruder figures cut with an auger and a chisel on the south side. Both sets are arabic numerals and both contain a few fragments of fourteenth-century color. It is possible that the large, crude set was designed differently simply to distinguish the south side from the north when the panels went to the painter's studio. There are also incised lines marking the exact location of the tracery and frames. The frames in their medieval position protected the paint when the panels were later cleaned with soda, so their outline is clear and accurately follows the incised setting-out lines. (It appears that the painter had been told that the panels were "a foot" wide, and he had prepared cartoons in advance without allowing for the width of the frames, because the figures are slightly cramped, often encroaching on the incised outline, and have sometimes been slimmed down by allowing the background vermilion to overlap them.) Traces of yellow were found on the crockets and in crevices elsewhere. Its hardness and pale lemon hue are characteristic of lead-tin yellow. English medieval oil gilding invariably was applied over some kind of reddish or orange ochre, so it seems clear that this yellow was a substitute for gold.

Each panel received an extremely thin priming of glue and chalk, barely filling the wood grain; in some places it cannot be seen under the microscope in a cross section. The top end remains bare wood, as it extends above the cornice. The area behind the tracery overlay, in the spandrels of the ogee arch, is green like the backboarding of the soffit overhead. This green is built up of a pale undercoat containing lead white and a rich, resinous glaze. The rest of the panel received a further undercoat of red ochre.

The vine was presumably added next, with black underdrawing; it is continuous and gradually tapers across both rows of panels, from a gnarled and much-pruned stem springing from Jesse, to fine twigs below the Annunciation. The stem is buff colored with green shading, and the leaves modeled with white veins laid over glazes (Fig. 4). There are many tendrils but no grapes. The figures standing on the vine display a rich and varied palette, with much use of crimson and other glazes. Many paint samples were taken during work in order to monitor the cleaning process,

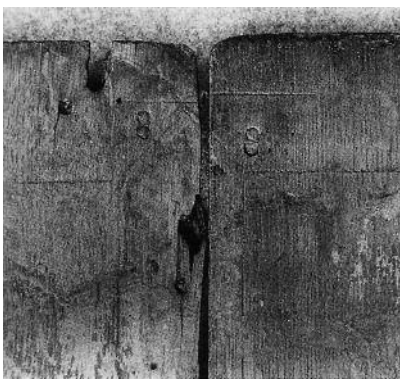

Figure 3

Detail of the panels of prophet Zechariah and King Mathan, showing the arabic number eight in the corner of each panel and incised setting-out lines for positioning the tracery frames.



Figure 4  
Vine below the feet of King Zadok (detail).

## Previous Interventions



Figure 5  
Face of Moses (detail).

and others are being analyzed.<sup>5</sup> They include vermilion, red lead, lead white, carbon black, azurite, malachite, copper green, a range of ochres, and two unidentified colors, a crimson lake and a translucent purple. The gold, which is applied on an oil mordant, was used with restraint. It is found on the crowns and scepters of the kings, Josaphat's belt, and on the halos of the Annunciation group, Gabriel's cope, and Christ's loincloth. (Water gilding, which has solubility characteristics completely different from oil gilding, is fairly uncommon on English medieval woodwork.) The vermilion background was obviously applied last, possibly with the panels already in situ, since a few neat, square-headed tacks bearing scraps that appeared to be of vermilion were found among many corroded nailheads of different periods that studded the edges of the panels. The tracery was then laid over the panels, and evidently pegged through them; it must have been polychromed before assembly, as there are no paint splashes on the figure panels. Among the last components to fit into position were the cornices and name boards, which were secured with nails, being much heavier than the rest.

The faces are modeled in shades of pink in the normal manner, with one particularly interesting exception—that of the Moses figure (Fig. 5). Here, flat pink was applied over the head and neck, followed by gray on the hair and beard. When this had dried, the features and curls of hair were boldly drawn by brush in black—a glass painter's technique.<sup>6</sup>

During the Reformation, evidently following the edict of 1547–48 against images, the three panels depicting Gabriel, the Virgin Mary, and the Lily Crucifix were concealed with a pinkish overpaint. Similar pink was found at Clifton, where the backgrounds are also vermilion, and on those rood screen panels at Ranworth, Norfolk, and Pilton, Devon, with red backgrounds. Presumably, the parishioners wished to spoil their polychromed furnishings as little as possible while keeping within the law. It was probably E. T. Long who removed most of this pink layer at Abingdon, during his 1935 work mentioned below.

At some stage, before any of the medieval framework was displaced, attempts were made to clean the ceiling with caustic soda (sodium hydroxide). Caustic soda was still occasionally used to clean English polychromy well into the twentieth century; it tends to raise the grain of the wood, and leaves oak surfaces a dull gray. It saponifies an oil medium, and—although it was usually rinsed off areas where it was not intended to strip the paint—its residue leaves the medieval oil paint permanently sensitive to any form of moisture. The ceiling may also have been dismantled and given a reddish resin varnish. Certainly, the nine westernmost panels on the north side, from Moses to Haggai, were taken down to be overpainted in 1854 or 1856, together with their name boards.<sup>7</sup> Until the overpaint was removed, between 1989 and 1991, these nine panels were the brightest in the ceiling and the most widely reproduced.

All of the panels were taken down in 1872, and the structural timbers of the roof completely renewed. The panels and their tracery were reassembled in a mixed sequence, thirteen panels from the south side and one from the north having been discarded. It must have been at this time that the polychromy was stripped from the tracery of both figures and soffit, although the soffit backboarding retained its richly glazed green.

These green areas were coated with a layer of thin black paint. The figure panels were nailed back onto horizontal softwood planks, at right angles to the grain of the fragile medieval panels.

In 1935, Long completed his very careful cleaning of the paintings, which resulted in Borenius's appreciative publication (1936). However, he was obliged to work in situ, and thus did not attempt a complete cleaning of the most fragile areas (notably the vine, onto which much caustic soda had run). Consequently, Borenius makes several inaccurate observations about the color. Long is recorded to have applied a "preservative," which at that date may well have been wax (Ballantyne and Hulbert 1993; Plummer and Hulbert 1990), or possibly size; traces of the latter were encountered during cleaning.

Blown-air central heating was later installed in the church, causing extreme fluctuations in relative humidity. During a winter weekend early in 1983, conservators recorded a drop in the relative humidity from 75% to 30% in the vicinity of the ceiling. Some twenty years of similar conditions had not only loosened the paint but also considerably degraded the oak. The figure panels, being constrained by many nails, were seriously weakened, but the tracery overlay survived in much stronger condition. It had probably suffered less stress because its design is pierced (Fig. 2). In addition to flaking paint and damaged wood, the ceiling was caked with dirt deposited by the current of hot air.

---

### "First Aid" and Preliminary Work

Early in 1983, when repairs to the tiled roof were about to begin, the church architect, John Glanfield, requested a report on the ceiling. The paint was found to be flaking so badly that it was imperative to secure it without delay. Paint consolidation was carried out over several weekends. This turned out to be extremely fortunate, for the presence of the conservators during weekends allowed them to observe the sharp rise in temperature and the associated drop in humidity on Saturday afternoons, after the heat had been turned on in readiness for Sunday worship; this was instantly diagnosed as the cause of the loose paint. In a March 1983 report, the author tentatively suggested that the Lady Chapel might be isolated from the effects of the blown-air heating by placing glass tympana in its arches. Before this scheme could be implemented, however, a great deal of investigation needed to be done. Meanwhile, for the foreseeable future, the parish had funds only for emergency work.

Since there appeared to be some wax on the panels already, and it was evident that a facing would have to remain on the paintings for some years, a mixture of beeswax and dammar (7:1) was chosen as a consolidant, melted through Japanese mulberry tissue with hot-air blowers and heated spatulas. The proportion of dammar was kept low, so that it could easily be removed if it did have to remain on the paintings for many years. A heat-melt adhesive has a great advantage over one requiring a solvent, in that shrinkage problems are minimized. Great care was taken to ensure adequate penetration of the wax so there would be no danger of the tissue pulling off the paint surface. The green area behind the tracery overlays could not be treated at this stage.

Expense precluded modification of the entire heating system, but the parish began to monitor the environment within the chapel. Conditions produced at the ceiling by the full blast of the nearby heating

outlet were compared to those produced by blocking the arcades with temporarily installed polythene (polyethylene sheet) tympana.<sup>8</sup> The introduction of these barriers caused the relative humidity—which had previously ranged from 40% to 70% or more—to level off to around 60–65%; the temperature—which had similarly fluctuated, from 6 °C to 34 °C—also became far more stable. In due course, it was clear that a permanent glass tympanum blocking each arch would provide effective protection for the ceiling, while allowing some air to circulate at ground level.

---

## Dismantling and Documentation

The ceiling's most complex problems were those involving the woodwork, which clearly demanded expertise in joinery. Accordingly, a preliminary report was prepared in 1983 by Hugh Harrison, consultant in the conservation of woodwork.<sup>9</sup> There were innumerable splits in both tracery and panels, frequently associated with corroded nails, and the medieval timber was in extremely fragile condition. A great deal of water must have seeped in before the 1872 repair of the roof, and the panels had suffered from fungal and insect attack. After the paint on the figure panels had been consolidated, three panels on the north side (Eleazar, Zechariah, and Mathan) were taken down in 1983 for investigation and were cleaned as funds became available during 1983–85.

In 1988, when John Glanfield retired, Martin Caroe took over as church architect. Caroe was responsible for coordinating the major part of the work and for assembling the varied team of specialists. Dismantling work was resumed in 1989 (Fig. 6); the last components came down in 1991. The many nails attaching the ceiling to the softwood planking were carefully sawn off behind the panels and their corroded heads later extracted from the oak. Softwood wedges sandwiched between small pieces of very thick Melinex, and inserted close to each attachment point, were used to gently pry apart the layers of woodwork.<sup>10</sup> Occasionally, splinters became detached from rotten edges, but these, however tiny,

*Figure 6*

North side of ceiling during dismantling. These were among the best-preserved figure panels. Note the construction of the soffit, above, and a section of the cornice with inscription, on the right.



were labeled and eventually adhered back in position. The most difficult panels to remove were, of course, the first in each row, as it was not easy to reach the 1872 nails. During work, an 1854 penny was discovered, with the date 1872 added to the adjacent woodwork in pencil. (In 1991, a new five-pence piece was similarly hidden during reassembly.)

When the tracery overlays had been removed, the green backgrounds, which could not be reached previously, were faced with Eltolene tissue and consolidated with beeswax and dammar (4:1). The edges of the panels that had been covered by the frames were similarly treated.<sup>11</sup>

Each component was carefully numbered, labeled, and mapped so the position of even the smallest piece was precisely located. For the soffit, this involved a scale drawing on transparent overlays representing the layer structure of the tracery. Reports were produced at the completion of each step of the work, resulting in a massive amount of documentation.<sup>12</sup>

In 1989, a photogrammetric record was made before further dismantling took place. A very important aspect was the tracing of each figure panel to scale as soon as it was cleaned (Fig. 7). Thick transparent Melinex or acetate sheet was used, and every detail recorded, down to the last nail hole. A full-scale photocopy was made of every tracing and mounted on hardboard to be used when sorting the tracery into its original order (for which the early peg holes were important evidence) and when fitting the new, concealed aluminum housing. This saved wear and tear on the paintings.

The tracings were also reduced in size in order to provide handy line drawings. These proved invaluable when checking the continuity of the vine trail—and, consequently, the original order of the panels—because soda-damaged details could be shown far more clearly in the drawings than in a photograph, and missing outlines could be recovered from surviving paint fragments. The lettering on the name boards also was traced where it was damaged (probably by soda residue) and this process proved an invaluable aid in deciphering some of the less legible names. Fortunately, the

Figure 7

Panels from Moses to Haggai, north side. These were the nine figures previously over-painted.





black paint had left a clear yellowish stain on the white background where it had been washed off during the early attempts at cleaning.

All parts of the ceiling were routinely photographed at significant stages of work, in color and in black and white. Before any wax consolidation was carried out in 1983, the faintest areas of the painting were photographed on infrared film, but this did not reveal anything significant. In addition, rubbings were made of several interesting toolmarks, setting-out lines, et cetera.

---

## Woodwork Repair

The repair of all the woodwork and the removal of corroded nails, together with the cleaning of all bare oak surfaces, the green soffit backboarding, name boards, and cornice inscriptions were carried out in the Devon workshop. The finest available quartersawn English oak was used for all repairs, but it was difficult to match the superb quality of the original timber. Poly(vinyl acetate) emulsion was selected as the adhesive for unpainted wood, since in this context it should prove adequately resoluble, and it is less sensitive to changes in humidity than traditional animal glue. A 20% solution of Paraloid B72 in xylene was used to consolidate decayed wood; the same resin was mixed with oak sawdust and used for fillings. Owing to the extreme thinness of the priming layer, it was often impossible to prevent the wood consolidant from reaching the paint surfaces, so it had to be safe for the paint as well as for the wood.

Splits in the tracery were glued and, where appropriate, reinforced with oak pegs. Lost pieces of carving that created an unsightly gap in the design or weakened a component were replaced, with care taken to minimize disturbance to the broken surface of the medieval wood. Some long splits in the panels were reinforced with V-shaped oak wedges at the back.

A special problem was posed by the discovery, behind the figure of Moses, of a tapered sliver on one of the panels discarded in 1872. Vermilion and green paint and incised lines identified it as coming from the upper part of a figure panel, but the foliage was painted much closer to the top of the panel than any other part of the vine. It seemed likely, therefore, that the figure had been a recumbent Jesse at the bottom of the panel, with some foliage above his head. This was confirmed when tiny fragments of dark crimson were found to match the drapery covering Jesse's giant feet at the bottom of Nathan's panel. (The recumbent figure originally spanned three panels, the middle one being that of the lost David.) The sliver was accordingly mounted in a recess in a new panel that was fractionally thicker than the medieval ones, and could thus be restored to its correct position.

Nahum's panel had occupied the easternmost position on the south side since 1872 and had become damp from contact with the exterior wall. It was consolidated before being taken to the Devon workshop. Not only was the wood seriously damaged by fungal attack, with cracks across the grain, but the panel had bowed across its width, creating a huge bulge. Before the facing could be removed, the back of the panel had to be thoroughly impregnated with Paraloid B72 (it absorbed about half a liter). The panel could not be enclosed in a fume hood because it was necessary to constantly monitor the paint surface for seepage of consolidant; therefore, the work was done outdoors where the xylene evaporated rapidly in the mild English sun. Fortuitously, it was discovered that the panel could be considerably flattened while warm; it was carried indoors, gently weighted,

and left to cool. The panel remained flat when the consolidant had fully hardened. Probably the same effect could have been achieved on a vacuum hot table, but since none of the other panels had bowed in this way, there was no occasion to explore further this purely accidental discovery. Its success probably depended on the combination of warmth and the precise moment at which the solvent had almost, but not quite, evaporated.

---

## Cleaning

Before the 1983 facing was removed from the figure panels, the paint surface was further impregnated with beeswax and dammar (3:1).

Isopropyl alcohol proved to be the most useful solvent for the old varnish; there was no danger of dissolving the fixing wax. However, a wide range of solvents were used on different areas. A 3% solution of ammonia was occasionally used, but with caution, for fear of reactivating the alkaline residue remaining from the previous intervention with soda. The special problems caused by the soda have been discussed elsewhere (Hulbert 1994). For the initial softening of overpaint, a commercial paint stripper (green label Nitromors), applied on a very small brush, was frequently indispensable. After this had been rinsed off with white spirit, the overpaint was sufficiently soft to respond to milder solvents.<sup>13</sup> The author has worked on more than thirty English medieval rood screens and church panel paintings, which over the centuries have usually received at least one coating that is now harder than the original polychromy. Experience has shown that a strong solvent used quickly and carefully, especially when its action depends on its vapor's reaching the surface of the overpaint from the gel, is far safer than prolonged use of milder solvents, which may begin to act on the original paint before the overpaint is soft enough to respond to gentle scraping. Preliminary tests with a wide range of solvents confirmed that this was the case with the overpainted panels at Abingdon. The most valuable tool, however, was a scalpel kept very sharp with a Belgian sharpening stone. A large part of the work on every panel was done under a binocular microscope at  $\times 10$  magnification.<sup>14</sup>

---

## Reassembly

The various clues by which the original sequence of the figure panels was rediscovered have already been published in detail (Hulbert 1992:19–20). Each prophet could be identified by his text. The name boards could be correctly positioned through reference to the list of kings in Saint Matthew's Gospel. There was nothing on the figure panels to identify the individual kings. However, by establishing the continuity of the vine trail, kings could be placed between the correct prophets, so that when the prophets were lined up with their names, the names of the kings would also be below the proper panels. The arabic numerals also confirmed the sequence, but the cruder numerals on the south side were not recognized until they were already in the correct order.

It was obviously essential to support the panels in some kind of housing that would not restrict movement, as the nails had. Since the chapel is just under 8 m (26 ft.) long, and the slope of the rafters creates a tapering space that absolutely precludes any additional thickness in the assembly of panels and tracery, this called for some ingenuity. After long discussions with colleagues, grant-giving bodies, and diocesan authorities, the following solution was devised by Hugh Harrison. All of the components were first fitted together in the workshop and then taken to the

church for reassembly. (Tracery components were pegged together in their respective sections.)

Aluminum was obtained in an H-shaped section to fit the panels. The slots of the H were lined with balsa wood (pretreated with insecticide) and the lengths of aluminum cut as necessary. Pieces that would be visible through apertures in the tracery were cut away. In places, distortion had occurred; such places required extra welded aluminum. Keyhole slots were cut to correspond with screws in the back of the tracery, which were inserted into existing, plugged holes; the slots were designed to allow some movement. (The screwheads were isolated from the panels by the balsa wood.)

The soffit was the last part to come down and the first to go up. It was secured with brass screws through existing holes. The aluminum sections were then accurately positioned, using the tracery as a guide (already slotted into place), and screwed to the softwood boarding, which had been retained. The tracery was unslotted, and the vertical pieces of aluminum unscrewed one at a time. One panel was inserted into the balsa-lined housing; the aluminum was then screwed back, using the same holes so the tracery would still fit the keyhole slots. The process was repeated until all the panels were in place and the tracery was slotted over them (Fig. 8). A further piece of aluminum was used to prevent each panel from slipping down. Holes had been predrilled for the vertical members of the frames, and the attachment of small individual items, such as finials, was also straightforward. Before the panels were in place, brackets were positioned and the cornice and inscription boards attached, using the old nail holes. The name boards were similarly fixed to blocks at the bottom. Stainless or nonferrous screws were used throughout and any visible heads covered with pigmented wax.

*Figure 8*

A portion of the south side of the ceiling during reassembly. King Asa, Prophet Baruch, and King Josaphat; some of the panels damaged by early attempts at cleaning. Note the blank panel on the right, with reconstruction of the vine trail under way.



The thick plaster into which the edges of Mary's and Nahum's panels had been deeply embedded was removed from the east wall and replaced with a thin layer of traditional lime and sand, feathered off just short of the ceiling.

---

## Retouching and Varnishing

After cleaning, the panels were very lightly waxed. Most unsightly lacunae were retouched in watercolor using a stippling technique, and gold powder in gum arabic was used to repair gilded areas. No imaginative reconstruction was attempted, and faces (with the exception of the tip of Joel's nose and Mary's cheek and chin) were left untouched. The thinnest possible varnish was applied, as the panels had to travel from one workshop to another and be stored wrapped in Melinex, and a normal thickness of varnish would not dry while thus wrapped.

When all the panels were back on site, more retouching was done to minimize the uneven effect of varied damage. The vine trail on the south side, much of which would have been invisible from ground level, was reconstructed by filling in the vermilion background only, using the tracing as a guide. A further thin dammar varnish matted with beeswax was applied in situ. A few details were finished with pigments in a medium of the same varnish.

Watercolor was also used for retouching the lettered boards. These were sealed with beeswax and dammar (3:1). A 4:1 mixture was used to polish all bare wood.

New oak was spirit stained to match the old. (The fourteen lost panels had been replaced in 1872 with very poor wood.) New blank panels were made, and the tops painted and glazed green behind the tracery overlays, using artists' acrylic paints. The vine was then reconstructed in outline to join with surviving adjacent panels, using raw umber pastel crayon, and the whole surface was toned down with raw umber acrylic applied with a sponge. Red watercolor was then applied by the same method, to simulate the vermilion background, leaving a "ghost" shape suggesting a figure but in no way reconstructing it. Finally, these panels were varnished. Acrylic paints were also used to color some modern sections of name board. This technique satisfactorily restores continuity to the composition, while remaining clearly distinguishable from the original painting.<sup>15</sup>

The stone cornice below the ceiling was cleaned, and the plastered walls of the chapel limewashed, the lime being pigmented to a warm tone.

---

## Lighting and Display

New electric lighting was installed. Unfortunately, it is impossible to avoid all reflection; had a more matte varnish been selected, the pigments would not have been as satisfactorily saturated. There is also a fine chandelier, dated by C. C. Oman to the early seventeenth century, and attributed to the Low Countries.<sup>16</sup> The candles of the chandelier are lit only for major feasts of the Church, including feasts of the Blessed Virgin, and are unlikely to burn for more than six hours a year. The chandelier hangs well below the ceiling, and its beauty is such that the small amount of soot may be disregarded, especially if low-soot candles can be obtained

Environmental monitoring continues, and results are regularly studied. One of the humidity monitors has been positioned on the chandelier. The ceiling is checked at close quarters by the author every few years.

Smoke detectors have been placed in the church; one is attached to the truss at the west end of the ceiling, and there is a loud siren on the tower.<sup>17</sup>

---

## Conclusion

It is a rare privilege to work on objects that are still in use for their original purpose, and it is fully appropriate that the ceiling should be enhanced by a sympathetic modern tapestry,<sup>18</sup> which takes up the theme of the Cross, associated with the church's patron, Saint Helen. Embroiderers within the parish designed kneelers that echo the vine trail. The ceiling was blessed by the bishop of Oxford on the last Sunday in Advent 1991, when the Bible readings for the season referred to Jesse.

Saint Helen's is an Anglican (Church of England) parish church. The congregation is responsible for raising the funds for maintenance, either from local donations or from charitable trusts and government funds. Work was carried out by private conservators after approval was obtained from diocesan authorities and any grant-giving bodies involved. The whole project demonstrated excellent and happy teamwork among all the specialists involved.

---

## Acknowledgments

In addition to all those named in the notes, warm thanks are due to the Reverend David Manship, Rector of Saint Helen's, and to many parishioners who provided practical help, hospitality, and support. During the second phase of work, the Reverend Allan Doig (curate) was responsible for a huge amount of organization, and the master and governors of Christ's Hospital, who administer medieval almshouses beside the church, generously assisted with facilities.

At different stages of the work, the following people participated in the Herbert Read team: Stuart Anderson, Laurence Beckford, Gareth Brown, Bob Chappell, Clare Cully, Ruth Davis, John Gentry, Dave Harvey, David Luard, Torquil McNeilage, Russell Powell, Richard Stokoe, Stephen Webb, and Brett Wright. The author's assistants were Mary Baker, Ann Ballantyne, Liz Cynddylan, Elwira Pluta, Jane Rutherford, Eddie Sinclair, and Katherine Stainer-Hutchins. Simon Egan polished paint samples. John Matthews, of Wessex Press in Wantage, took extraordinary trouble over the reduction photocopies of my tracings. Local builder Alan Norridge was endlessly helpful with many essential tasks.

The National Heritage Memorial Fund and English Heritage contributed two-thirds of the cost of the work; the parish raised the rest, assisted by Saint Andrew's Trust of Wells, the Council for the Care of Churches (Pilgrim Trust), the Sainsbury Trust, the Abingdon Environmental Trust, Christ's Hospital, Abingdon, and numerous local businesses and individuals. The project won a National Art Collections Fund award, which was added to these donations.

---

## Notes

1 "Relaxation of four years and four *quadrage* to penitents . . . the like to penitents who on the four feasts of St. Mary the Virgin similarly visit and give alms to her altar in the church of St. Helen, Abingdon." 2 Kal. March 1391 (Bliss and Twemlow 1902:407).

2 Fourteen examples are listed in Hildburgh (1925; 1932) and Edwards (1979). There is another on a window mullion at Wellington, Somerset.

- 3 The ceiling was closely examined by Gavin Simpson and Robert Howard of the Department of Classical and Archaeological Studies at the University of Nottingham. For their dendrochronological and other findings, see Howard and coworkers (1992:53, 56).
- 4 The author's attention was drawn to this fact by Jerry Sampson, a consultant archaeologist who undertook archaeological observation throughout the project.
- 5 Analysis is being carried out by Caroline Babington at the conservation studio of the Historic Buildings and Monuments Commission for England (English Heritage).
- 6 Michael Liversidge of the Department of History of Art at the University of Bristol (to whom I am much indebted for his continuing art historical input) has drawn my attention to the very close affinity of the Abingdon paintings with the contemporary work of Thomas the glazier of Oxford. Harvey (1975), in his chapter on painting, comments on the association between glaziers and other painters.
- 7 Mieneke Cox, of the parish, drew my attention to a letter from a "Miss D'Arcy," who recollected the event. The repainting was done by Emma Dodson, the vicar's daughter, under the direction of the architect, Mr. Clacy. D'Arcy recorded the disintegration of panels during this dismantling, which may have caused the project to be abandoned. Art historians have accordingly judged the Abingdon master by the poor quality of Dodson's work. D'Arcy's letter is quoted among the Preston papers in the Berkshire Record Office, File D/EP 7/63. Reading, England.
- 8 This was done under the direction of R. J. Noyes of the Culham Laboratories; the late Keith Dawson of the Rutherford Laboratories, Harwell; and David Saunders of the National Gallery, London. William Bordass, building scientist, later continued the measurements.
- 9 Harrison, at that time, was the managing director of the Devon ecclesiastical joiners, Herbert Read Ltd., a firm established in 1888, combining traditional joinery skills with those of modern conservation. He is now an independent consultant.
- 10 The materials mentioned here and in the following sections—such as Melinex, Eltolene, and Paraloid B72—are available from most conservation materials suppliers.
- 11 This was carried out by conservators from Herbert Read Ltd.
- 12 The reports were produced by the author and Hugh Harrison. The documentation was eventually collated by Jerry Sampson.
- 13 The Nitromors was a commercial paint stripper in gel form, containing methylene chloride. It was an old formula that may now be unobtainable.
- 14 Similar methods were used for the polychromed items cleaned by Herbert Read's team, for which the author was consultant.
- 15 The technique was devised with the assistance of conservator Ann Ballantyne.
- 16 Installation of the electric lighting was carried out under the direction of Martin Caroe, in consultation with Ronald Clough. For chandelier dating, see Oman 1937. Martin Caroe designed the glazed tympanum at the west end of the chapel as an extension of the nineteenth-century screen below, and the glass has been lettered with a translation of the text on Mary's scroll by calligrapher David Peace.
- 17 The environmental monitoring is carried out by William Bordass, environment consultant, and Martin Caroe.
- 18 The tapestry is the work of weaver Bobbie Cox.

---

## References

- Ballantyne, A., and A. Hulbert  
 1993 19th and early 20th-century restorations of English mediaeval wall paintings: Problems and solutions. In *Peintures murales: Journées d'études de la S.F.I.I.C.* [French section of the International Institute for Conservation]. Champs-sur-Marne: S.F.I.I.C.

- Bliss, W. H., and J. A. Twemlow, eds.  
1902 *Calendar of Entries in the Papal Registers Relating to Great Britain and Ireland, Vol. 4: Papal Letters, A.D. 1362–1404*. London: Eyre and Spottiswoode.
- Borenus, T.  
1936 An English painted ceiling of the late fourteenth century. *Burlington Magazine* 68(399):268–76.
- Campbell, M.  
1991 Gold, silver and precious stones. In *English Medieval Industries: Craftsmen, Techniques, Products*, ed. J. Blair and N. Ramsay, 107–66. London: Hambledon Press.
- Edwards, J.  
1979 Lily-crucifixions in the Oxford district. *The Oxford Art Journal* 2:43–45.
- Harvey, J.  
1975 *Mediaeval Craftsmen*. London: Batsford.
- Hildburgh, W. L.  
1925 An alabaster table of the Annunciation with the crucifix: A study in English iconography. *Archaeologia* 74(2nd series 24):203–32.  
1932 Some further notes on the *Crucifix on the Lily*. *Antiquaries Journal* 12:24–26.
- Howard, R. E., R. R. Laxton, C. D. Litton, and W. G. Simpson  
1992 Nottingham University tree-ring dating laboratory results (list 44). *Vernacular Architecture* 23:51–56.
- Hulbert, A.  
1992 The recovery of the Jesse Tree sequence of panels in St. Helen's, Abingdon. In *The Conservator as Art-Historian*, ed. A. Hulbert, J. Marsden, and V. Todd, 19–20. London: United Kingdom Institute for Conservation.  
1994 A useful method of cleaning soda-damaged mediaeval panels. *Picture Restorer* 6(autumn):8–10.
- Liversidge, M. J. H.  
1965 *The Fourteenth Century Decorated Ceiling in St. Helen's, Abingdon*. Church guidebook. Abingdon.
- Oman, C.  
1937 English brass chandeliers. *Archaeological Journal* 93:263–82.
- Plummer, P., and A. Hulbert  
1990 English polychromed church screens and the problems of their conservation in situ. In *Cleaning, Retouching and Coatings*, ed. J. S. Mills and P. Smith, 47–51. London, International Institute for Conservation of Historic and Artistic Works.
- Preston, A. E.  
1936 The fourteenth century painted ceiling at St. Helen's Church, Abingdon. *Berkshire Archaeological Journal* 40(2):114–41.
- Tristram, E. W.  
1955 *English Wall Painting of the Fourteenth Century*. London: Routledge and Kegan Paul.
- Watson, A.  
1934 *The Early Iconography of the Tree of Jesse*. London: Humphrey Milford and Oxford University Press.

# The Interior Decor of the Ursuline Chapel in Quebec City

## Research and Conservation

*Claude Payer, Marie-Claude Corbeil, Colombe Harvey, and Elizabeth Moffatt*

**D**URING THE EIGHTEENTH CENTURY, the interior of few churches in New France could rival that of the Ursuline Chapel, in the complexity of iconography, the richness of carving, or the extent and variety of gilded and polychromed surfaces. It was one of the rare interiors to survive the bombardment of Quebec City by the British in 1759. It has also been spared from fire and saved from the dispersal that often accompanies changing tastes. Today, it is the only assemblage of furnishings from the French regime that is nearly intact, making it one of the oldest extant in North America. For these reasons, it is exceptional.

The first Ursulines arrived in New France in 1639 to establish a school for girls. In 1642, they moved to a building situated on the heights of Quebec City, on a plot of land that their convent still occupies today. An initial fire in 1650 and a second in 1686 obliged them to completely rebuild twice. After the second fire, they had to wait until 1723 before their new chapel was finished. It was a stone building, featuring a nave (or outer chapel), reserved for the general population; a sanctuary, later to be embellished with the rich carved furnishings that are the subject of this article; and, to the right (liturgical south) of the sanctuary, the nuns' chapel, a place of prayer for the Ursulines and their pupils (Fig. 1). Since this was a cloistered community, the nuns' chapel was enclosed by a screen.

*Figure 1*  
Floor plan of the Ursuline Chapel, in Quebec City, as it is today.

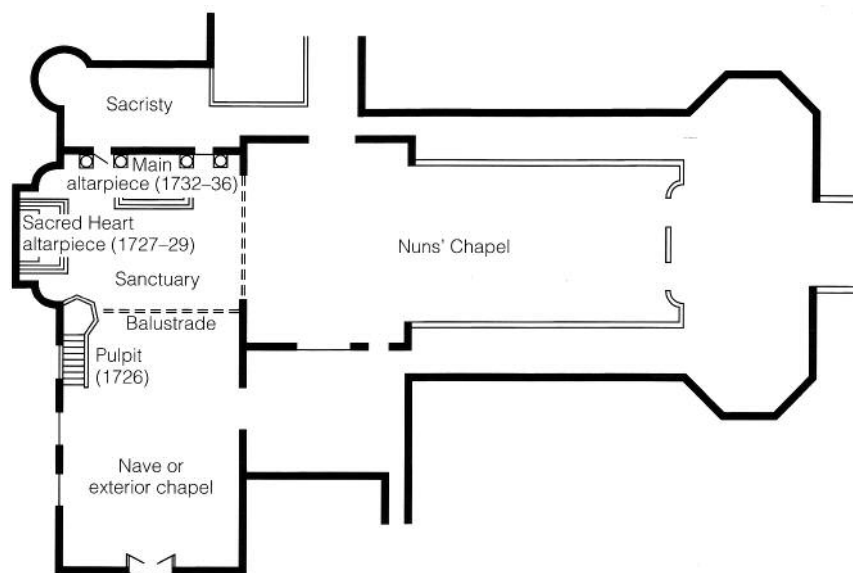



## The Decor

Located mainly in the sanctuary, the furnishings were provided over a ten-year period, between 1726 and 1736. First, the pulpit was installed on the north wall at the junction of the nave and the sanctuary. This was followed by the Sacred Heart altar and altarpiece,<sup>1</sup> which were situated within a recessed bay on the north wall, facing the nuns' chapel. Finally, the main altar and altarpiece at the east end were completed, facing down the nave toward the congregation. Included in the ensemble were a few statues and older reliquaries salvaged from the fire that destroyed the earlier structure.

The iconography chosen by the nuns for this group of sculptures is among the most elaborate ever created in Quebec. The main altarpiece, constructed in the form of a triumphal arch, symbolizes a gate leading to heaven (Fig. 2). It contains statues of Saint Joseph, the patron of New France; Saint Augustine, one of the Church fathers whose rule the Ursulines follow; and Saint Ursula, the patroness of the community. Reliefs of the Annunciation adorn the panels of the sacristy doors, and the pedestals bear reliefs of Saint Peter, Saint Paul, Saint John the Baptist, and Saint John the Evangelist—veritable pillars of the Catholic Church. The high-altar painting, an *Adoration of the Shepherds*, is in an expertly carved, arched frame adjoined by four Corinthian columns with twin pilasters (Fig. 3). A relief of *The Good Shepherd* embellishes the richly decorated tabernacle, which contains a number of saints' relics.

The convent archives contain the 1730 contract for the main altarpiece and balustrade, signed by Pierre-Noël Levasseur (1690–1770), one of the most illustrious members of the Levasseur dynasty, a family of sculptors and craftsmen famous in New France. Historians also attribute to him (or at least to his family) the pulpit and the Sacred Heart altarpiece.<sup>2</sup> The contract mentions approval of a drawing initially submitted by the artist, but now lost. All of these architectural structures, including their decorative reliefs and motifs, statues, and items of furniture, were carved in wood, chiefly white pine and basswood, and were assembled using traditional joinery techniques.

Figure 2

The interior of the Ursuline Chapel, prior to the 1901 demolition, showing the main altarpiece, the pulpit, and the balustrade (photographer unknown). Archives des Ursulines de Québec A1-142 (copy print, May 1993).

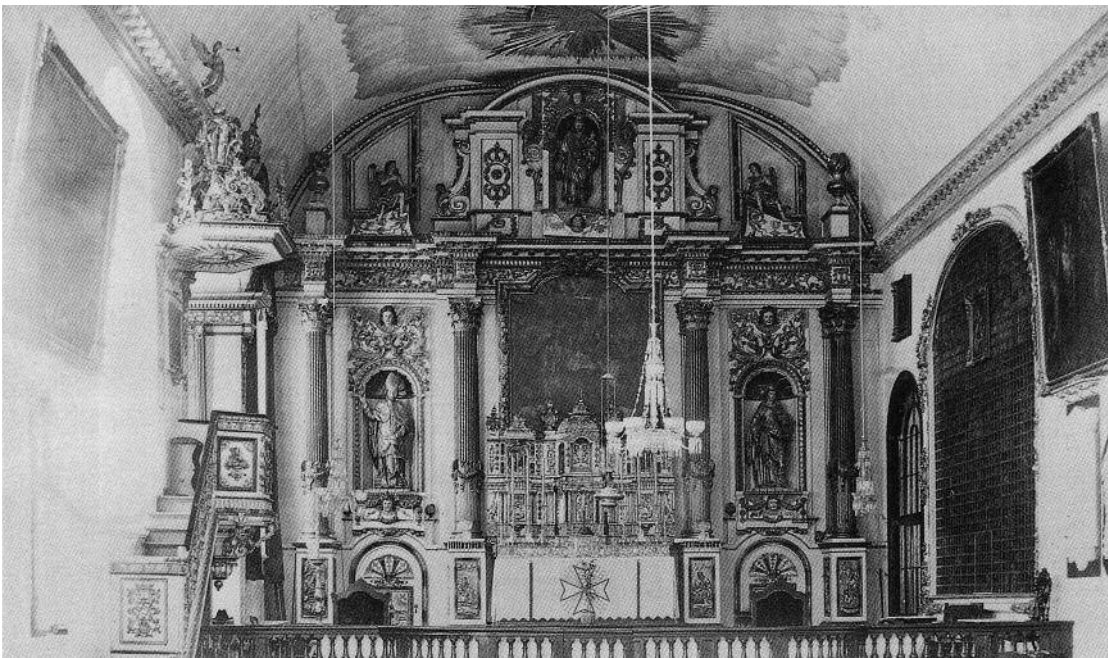

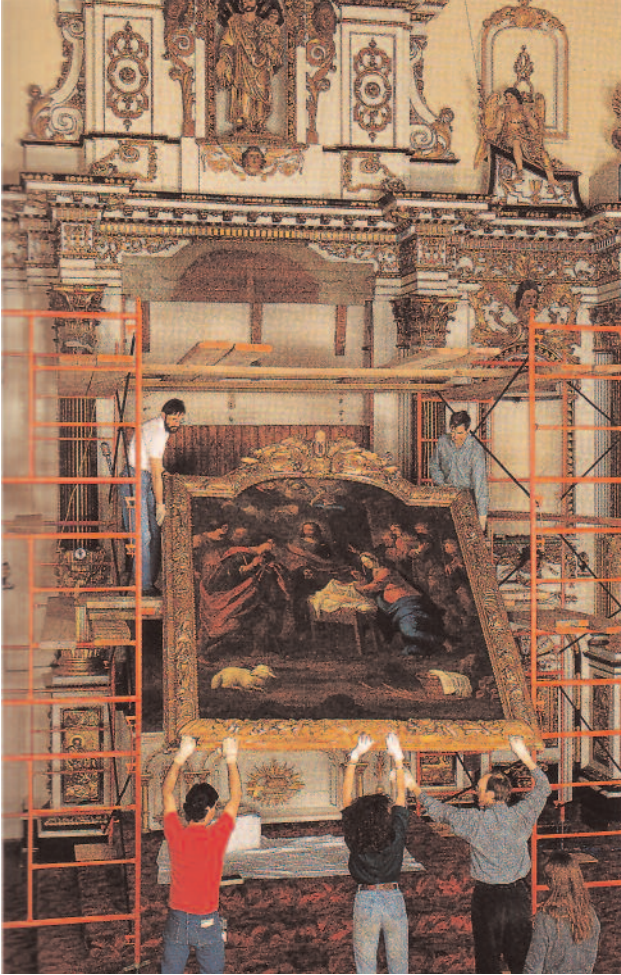

Figure 3  
The high altar painting being taken down for treatment in February 1994.

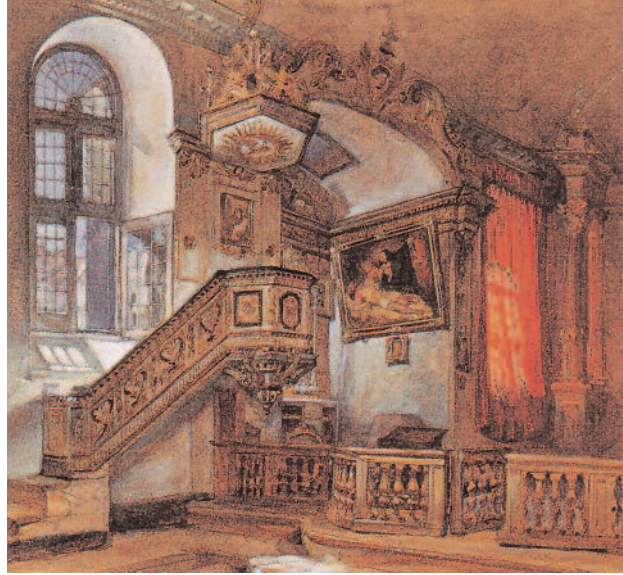

Figure 4  
Tabernacle of the Sacred Heart altar, with statuettes and reliquaries. Various motifs resulting from *recutting* the gesso ground during the gilding operations can be seen on the surface of the tabernacle.

All polychromy and gilding, however, were excluded from the contract and were carried out by the nuns themselves. It is known that a number of the Ursulines were painters, and that the order operated a celebrated gilding workshop that served parishes and communities in and around Quebec City (Porter 1975).<sup>3</sup> They meticulously executed all the gilding and polychromy for their chapel according to traditional techniques, a task that probably continued for three years following the completion of the sculpture, just in time to celebrate the 1739 centenary of the nuns' arrival in New France. All visible parts of the wood were first covered with a gesso ground. The flat beds of the wooden architecture, as well as the walls, the background of niches, and the hollows of the pilaster capitals, were painted pale blue. Many sections of molding in the entablature, pedestals, outlines of doors and panels, and the fluting of the columns and conch shells were painted black to imitate ebony. The statues' hands and faces, the cherubs, and the angel heads were painted with flesh tints. With one exception, the clothing and wings of the figures were water gilded. The column capitals and lintels, tabernacles, and reliquaries, as well as the wall appliqué and ornamental motifs, were also completely gilded. The gilders made great use of *recutting*: incising geometric and floral motifs directly into the white ground (Fig. 4). Gold leaf was applied over a reddish brown bole, then burnished with agate stone in selected areas to create contrasts in brilliance. As a finishing touch to the gilding,

Figure 5

John Richard Coke-Smyth, *Interior of the Chapel of the Ursuline Convent, Québec, 1838*; watercolor on paper with graphite underdrawing, highlights of body color, 25.5 × 28.5 cm. This watercolor shows the decor a century after it was created: the pulpit, the balustrade, and part of the two altarpieces. A side window provides dramatic raking light for the main altarpiece. The red drape filters the light and accentuates the contrasts between gilded surfaces and blue-colored walls.



many hollows were highlighted with red watercolor. These different surface treatments produced visual contrasts, accentuated in the evening by gleaming candles and during the day by lateral light from broad windows. Two large windows draped in red were situated to the left of each of the altarpieces, producing a dramatic raking light (Fig. 5).

In 1901, however, during work to enlarge the nuns' chapel, it was discovered that the walls of the outer chapel and sanctuary building were badly deteriorated. It was decided that the furnishings would be disassembled and reinstalled the following year in a completely new building erected on the same site. While the new structure essentially adopted the same form as the old one, the architect increased its scale: the vault was raised, the side chapel expanded, the fenestration modified, and the balustrade (communion table) simplified. Elements of the sculpted decor were also modified to suit their new home. Architectural elements on the walls that served to integrate the furnishings and the architecture were eliminated, including parts of the entablature of the Sacred Heart altarpiece and the pulpit. The springing of the principal vault is now much higher than that of the main altarpiece, breaking the original continuity of horizontal lines in the decor. The raising of the vault also created large voids above the altarpieces, which the architect filled with appliqués and other accessories (Fig. 6). Elimination of the large side windows resulted in the loss of the raking light on the altarpieces and, thus, a flattening of the relief and a dulling of the Baroque character of the work. The contrasts of color and brilliance, the sculptural relief, and the richness of surface finishes accentuated by the various light sources of day and night had created an effect that was both grand and theatrical. A large part of this disappeared in 1902 during the reconstruction of the building.

Repairs and changes to the gilding and to the painted surfaces, which had been carried out at various times over the years, also contributed to changing the balance of forms and colors. For example, dull colors (white and beige) applied over the blue backgrounds have diminished the impression of volume that the backgrounds originally conveyed.



Figure 6

The side altar and altarpiece, called the Sacred Heart altarpiece. In 1902, the empty space above the sculpted decor was filled with a stained glass window and other accessories.

As a result, we now have an early-twentieth-century building that somewhat clumsily houses extremely important early-eighteenth-century furnishings. Despite the building and the overpaints, the decor still retains much of its majesty and refinement. Its age, history, and uniqueness, together with its high artistic and technical qualities, have earned it the designation of a historic monument by the Government of Quebec under the Cultural Property Act, as well as the recognition by art historians across Canada as a jewel of the nation's cultural heritage. Today, the chapel continues to serve the Ursuline community and the public as a place of prayer.

---

### The Conservation Program

In 1988, at the nuns' request, the Centre de conservation du Québec (CCQ) submitted a report and proposals concerning conservation of the decor. At that time, it was concluded that the furnishings and decorative elements were suffering from surface abrasion; flaking of the gilding and polychromy; damage from wood-boring insects; and cracks, marks, and losses due, among other things, to the work of 1901–2. The bright, contrasting water gilding had been covered, in large part, by dull layers of oil gilding and bronze paint, and the statues' faces had been darkened by crude overpaints. The ebonized surfaces had been covered with a matte black paint, now dusty and lifeless. The report recommended a long-term program. Most urgent was the aim of the first stage: to preserve the decor—that is, to undertake a treatment designed to slow the deterioration of the sculpted works. Only then could the second phase—namely, the aesthetic treatment—be undertaken. The goal was to understand the decor by systematically documenting it, to consolidate its structural and surface elements, and to carry out several preventive measures. Any attempt to improve its appearance without ensuring the survival of its component parts would be fruitless.

After a couple of years, during which the decor received its designation as a historic monument and the necessary funds were secured, the nuns gave the CCQ a mandate to implement the first phase of this conservation program. With grants from the provincial and federal governments and the financial participation of the Ursuline community, a small team of sculpture conservators with expertise in polychromed wood was formed. An advisory committee was created to serve as a forum for discussion of all major questions. The committee consisted of Ursuline nuns, CCQ members, a delegate from the Canadian Conservation Institute (CCI), a representative of the Quebec Department of Culture and Communications, and an art historian acting as special advisor to the Ursulines. This ad hoc committee met whenever necessary. Work proceeded over a four-year period until the fall of 1995. The scope and resources involved make this in situ project a first in Canada. The project has also taken on an exceptional character by virtue of the uniqueness of the object being treated.

Apart from the consolidation of an insect-damaged column, all operations were carried out in the chapel itself. Each of the three sections of the decor was scaffolded in turn for access. An enclosed workshop was laid out in the nave to offer a suitable space for treatment of the movable elements, for all writing and drawing, and to separate the conservators from visitors, since the chapel is open to the public during the tourist

season. The workshop area, measuring 9 m by 4 m, consisted of a very simple freestanding structure made of wood and drywall boards. It was illuminated with daylight-balanced, UV-filtered fluorescent lights, and sufficient electrical outlets were provided for all equipment. The workshop also contained a photography area, worktables, storage space for tools, and an area for a computer, a tool we found indispensable.

---

## The Documentation

On a job site of this complexity, documentation is both crucial and complex. All parts of the decor have been measured, probed, photographed, drawn, and described in writing. The CCQ photographer took black-and-white photographs and 35 mm color slides, and sometimes color 4 × 5 in. transparencies and X rays. A draftsman did most of the drawings from black-and-white 8 × 10 in. prints; these drawings were complemented and annotated by the conservators. Types of joints and hardware; tool marks; evidence of modifications, additions, and removals; losses and areas of damage; and the many layers of original finishes and overpaints were all noted.

The computer (a word processor, with a laser printer) allowed us to standardize written documentation and add to it as work proceeded, and to establish adequate files without needing to leave the premises or to employ a secretary. Diskettes and hard copies were kept on the job site; backup diskettes were stored elsewhere. The user-friendly software package (WordPerfect for Windows), compatible with equipment at the CCQ, enabled each of the conservators to enter data and consult that of others. It was considered too expensive and complicated to digitize the visual data (photos and drawings).

---

## Materials Analysis

The wood, gold-leaf alloys, pigments, and paint media were analyzed by a team of conservation scientists from the Canadian Conservation Institute in Ottawa. CCI made this a major research project and designated a coordinator, who also served as CCI's representative on the advisory committee.

By removing the paint in small areas layer by layer and preparing cross sections, it was possible to determine the original appearance of the sculpted furnishings. The following sections will discuss the original materials (i.e., the wood, the ground, the polychromy of the architectural elements and of the carved figures, and the gilding), as well as the general composition of the overpaints. The results of the analyses of the original paint layers are summarized in Table 1.

### Methods of analysis

Three types of samples were taken: fragments of wood, cross sections of paint or gilding, and particles of paint or varnish. The wood samples were examined by incident light and polarized light microscopy.

The paint and gilding cross sections were prepared according to standard methods but were dry polished with progressively finer, cushioned abrasives.<sup>4</sup> This method of polishing was preferred to the conventional method, which uses an alumina suspension in water, in order to avoid dissolving the water-sensitive paint layers. The cross sections were examined by light and fluorescence microscopy, generally with a ×40 magnification, and then by scanning electron microscopy. The latter at times made it possible to distinguish layers of very similar color but of

Table 1 Composition of original paint layers

	Painted architecture		Painted parts of carved figures		Gilded parts	
	Blue surfaces	Black surfaces	Flesh tints	Hair	Water gilding	Ochre surfaces
Highlights					red ochre or vermilion, calcite, and gum arabic	
Gilding and polychromy	Prussian blue, calcite, and protein	charcoal black, calcite, and protein	vermilion, lead white, lead carbonate, and drying oil	raw sienna, burnt umber, calcite, trace lead white, drying oil, and protein	matting glue gold leaf  bole: burnt sienna, red ochre, charcoal black, kaolin, calcite, and protein	yellow ochre, calcite, silicates, and protein
Size	calcite and protein					
Ground	calcite and protein					

different composition. Conversely, light microscopy helped to distinguish layers of identical composition that were separated by a very fine layer of dirt or that were of slightly different colors. By combining the two methods, it was therefore possible to establish the stratigraphy of the samples with greater precision. Examination by scanning electron microscopy (SEM) was coupled with analysis by X-ray energy spectrometry. The latter allows the detection of chemical elements with an atomic number equal to or greater than 11 (sodium). Furthermore, certain layers of paint were analyzed in situ by X-ray microdiffractometry using a 30  $\mu\text{m}$  collimator.

The composition of the alloys used for the gold leaf was determined by X-ray energy spectrometry combined with SEM.

Identification of the pigments and extenders in the samples of paint particles was done by X-ray diffraction using a Gandolfi camera, and by polarized light microscopy. The nature of the medium was determined by Fourier-transform infrared (FT-IR) spectroscopy using a diamond cell microsampling device and an infrared microscope accessory. This method also served to confirm and complement identification of the pigments in the sample. Samples of some layers of the cross sections were also analyzed in this way. Infrared spectroscopy and gas chromatography were used to analyze some varnish samples.

### Wood identification and dendrochronology

Most of the wood in the altarpieces and pulpit was identified as either white pine (*Pinus strobus*) or basswood (*Tilia* spp.). White pine seems to have been used mostly for the Sacred Heart altarpiece, while basswood was used for the main altarpiece, with the exception of the tabernacle, which was made of white pine. The two statuettes on the Sacred Heart tabernacle and the frame of the painting above them, as well as the angels sitting on top of the main altarpiece, are made of white oak (*Quercus* spp., subgenus *Leucobalanus*).

In the case of the basswood and white oak, it is impossible to distinguish between European and North American species by microscopy. *Pinus strobus*, on the other hand, is a soft pine indigenous to northeastern

North America, and was a rare import into Europe in the seventeenth century. Dendrochronology, which was provided by the Centre d'Études Nordiques (CEN) of l'Université Laval, in Quebec City, helped to confirm the origin of the white pine more specifically (Delwaide and Fillion 1993; 1994).<sup>5</sup> The growth curves from elements of the tabernacles were a very close match to the curves established by the CEN for *Pinus strobus* grown in Quebec and for a beam of white pine that had been taken from a wing of the Ursuline convent rebuilt in 1688. This leaves no doubt as to the origin of the white pine for many elements of the decor. Analysis of the wood also demonstrated that the butternut (*Juglans cinerea*) frame of the high altar painting must have been carved in New France as well, since butternut is found only in North America.

Dendrochronology was also used to estimate the age of the two tabernacles. The tabernacles were not specifically mentioned either in the account books or in the contract for the main altarpiece. Some historians believed that the Sacred Heart tabernacle was of French origin, a theory disproved by identification of the wood as *Pinus strobus* (Fig. 4). One school of thought held that one of the two tabernacles had been carved by Jacques Leblond de Latour, an artist who died in 1715. However, analysis of the growth rings of the white pine has set the probable year of felling at 1721 for the Sacred Heart tabernacle and 1719 for the main tabernacle (Delwaide and Fillion 1993; 1994); this would rule out the participation of de Latour and suggests that the tabernacles are probably the work of Pierre-Noël Levasseur. The main tabernacle could have been modified, however, and the limited number of measuring areas leave the dating and origin of some of its components in doubt.

## Ground

The first layer observed in the cross sections is the ground. This layer, lying directly on top of the wood, is generally a typical gesso composed of calcite in a protein medium.<sup>6</sup> However, there are a few exceptions. In a sample from the central motif of the Sacred Heart altarpiece, dolomite appears instead of calcite. In samples taken from the pedestals and the entablature, a mixture of calcite and gypsum was identified; the medium could not be identified because of interferences due to the gypsum in the infrared spectrum. In a sample from the flesh tints of the angel with the trumpet (Fig. 7), the ground is composed of calcite and protein, but a trace of drying oil was also detected. This oil may be from the oil-based layer applied over the ground (see "Polychromy of the carved figures" section).

On the ground, there quite often appears to be a layer of size; in some cases, it appears as a brownish transparent layer, in others as a yellowish infiltration in the upper part of the ground layer. The brownish layer and yellowish infiltration were analyzed and proved to have the same composition as the ground. A layer of size would make the ground less porous, preventing penetration of the medium from the paint applied over it, in order to obtain bright and resistant colors.<sup>7</sup>

## Polychromy of the architectural elements

Most surfaces of the altarpieces and the pulpit—that is, the backgrounds and flat surfaces—as well as the robes of the angels sitting on top of the side altarpiece, were painted pale blue. In general, the blue layer contains Prussian blue and calcite in a protein medium. In some cases, gypsum and

Figure 7

Documenting the pulpit. The angel with the trumpet can be seen on top of the sounding board.



traces of lead white and drying oil, or traces of drying oil alone, were also detected. In one sample, gypsum and indigo were found, in addition to Prussian blue, calcite, and protein.

As may be seen from the description above, the layer of blue varies in its composition and appearance: the color varies from blue to green, from very pale to dark, and from translucent to opaque. The shift in color of Prussian blue from blue to green over time has been noted by a number of authors since its introduction as a pigment. These reports were recently summarized by Kirby (1993).<sup>8</sup> Some attribute this color shift to the presence of oil, association with a white pigment (the paler the blue, the more it tends to become green), or the reaction of Prussian blue with basic compounds, which produces yellow and brown iron salts. Some samples of blue paint contained traces of oil, probably through contamination from the upper layers; no yellow or brown compound was observed by microscopy. Unintentional variations in the composition of the blue paint, which was applied to these large surfaces over a period of a few years, might explain the variations in its appearance. The hypothesis that these gradations were deliberate can be ruled out, as no logical repetition in the different tints of blue was noted.

Another interesting fact deserves mention with regard to Prussian blue: when observed by optical microscopy, the particles of Prussian blue did not resemble those of the modern pigment, but rather they resembled particles of ultramarine. Nevertheless, there is no doubt that the pigment is Prussian blue, since this pigment has a characteristic infrared spectrum. The same observations have been made by Welsh (1988) regarding samples of original paint taken from an eighteenth-century building in Philadelphia, and by Townsend (1993) regarding samples from works by Turner. The difference in appearance between particles of old and modern Prussian blue was attributed to different methods of preparation (Welsh 1988).

Certain elements of the decor, mainly the moldings, the hollows of fluting, and certain backgrounds, were originally painted black to imitate ebony wood. The black paint consists of charcoal black and calcite in a protein medium. It is usually covered with a thin layer of proteinaceous material, most likely a size applied to give it protection and gloss.



## Polychromy of the carved figures

The decor includes several full-length sculptures of saints and angels, as well as winged angel heads and masks. The clothes of most full-length sculptures were entirely water gilded; this technique will be discussed in the next section. The robes of the two angels in the Sacred Heart altarpiece were originally painted in the pale blue previously described, and were embellished with water-gilded stars. Therefore, this section will discuss more specifically the remaining parts of the polychromy—that is, the flesh tints and hair of the figures.

In all the samples of flesh tints, lead white and lead carbonate in a drying oil were identified. The red pigment used to tint the paint a flesh color was not detected by any analytical technique. Microscopy shows very few red particles, which made identification difficult. However, on the basis of the microscopic examination of the particles, we may assume the pigment to be vermilion.<sup>9</sup>

The brown hair of the angels in the side altarpiece was painted with a mixture of raw sienna, burnt umber, calcite, and a small amount of lead white in a mixture of drying oil and protein.

## Gilding

The original layer of gold leaf is set on a reddish brown bole composed of burnt sienna, red ochre, charcoal black, calcite, and kaolin in a protein medium. The gold on sand found in a few spots at the top of the main altarpiece and of the two tabernacles is applied on a yellow bole that consists of quartz, yellow ochre, calcite, and clays in a collagen-type protein medium (Fig. 8).

The composition of the gold leaf varies from 21.5 to 24 carat. Six different compositions were found. Most gold-leaf samples were alloyed with silver and copper, and just one contained only copper in addition to the gold.

In some samples, the original gold is covered with a thin layer of either varnish or matting glue (size). In one sample from the pulpit, this layer was composed of calcite and silicates in a mixture of protein and drying oil; on a reliquary, it was essentially drying oil; on a wall appliqué and on the robe of an angel, the varnish was made of copal dissolved in linseed oil; on the reliefs of the main altarpiece pedestals, it was linseed oil. We may assume that the matting layers are original, since the application of a matting agent is part of the traditional technique of gilding. It is less obvious, however, whether the layers of varnish are original. It should be mentioned that most of the reliquaries and appliqués came from other places in the convent, and that several were not contemporary to the chapel. It is therefore possible that they were varnished when they were installed in the chapel in order to give them a finish (a patina) that integrated well with the rest of the furnishings.

Certain parts of the gilded areas, sometimes complete motifs in the case of the pulpit, were painted yellow, no doubt to economize on gold leaf but also to create contrasts. For example, in the upper part of the pulpit, every second gadroon is gilded, and the others are painted yellow. The yellow paint is composed of yellow ochre, calcite, and silicates in a protein medium. In certain samples, the yellow paint was covered with size, which was identified in a sample taken from the pulpit as a mixture of calcite and animal glue.



Figure 8  
Detail of the main altarpiece showing part of the entablature, the upper part of the left niche, and the head of the statue of Saint Augustine.

Quite fine and often translucent red highlights were applied in the hollows of the gilding and the parts painted yellow, accentuating the effect of depth and volume. On the pulpit, red ochre and gum arabic were used; on the angel with the trumpet, vermilion and calcite (also in gum arabic) were used.

We may conclude that the parts to be gilded were first defined by application of the bole. Next, the gold leaf was applied and burnished in places, the ungilded surfaces were painted yellow, and then the red highlights were added. Here, the order of the gilding operations, as well as the application of red highlights with watercolor, are variations on the traditional gilding technique. It was usually the custom to first yellow the hollow areas, then apply the bole, and finally add the gold leaf (Watin 1773:149–60).

### Composition of the overpaints

The original blue surfaces were overpainted more often than surfaces of other colors. They were first repainted blue, most likely at the end of the eighteenth century. In some places, one or two additional layers of blue paint were observed, which could be localized overpaints. All blue layers were applied using a technique similar to the original. The blue was later covered with a pink overpaint layer composed of lead white, vermilion, Prussian blue, drying oil, and a significant amount of barium sulfate, which indicates that the overpaint was applied after the end of the eighteenth century (Feller 1986:47–64). The pink layer is covered with five white overpaints, all containing lead white and drying oil, except for the last one, which consists of lithopone (barium sulfate and zinc sulfide) and calcite.

The dark-colored surfaces, such as the black elements and the brown angel hair, in general, were overpainted only once. The ebony black was overpainted in a matte black. The flesh tints were overpainted three or four times. The layer visible now, like the last white overpaint, contains lithopone. In addition to lead white, the second layer contains barium sulfate, indicating that this overpaint, like the pink overpaint, was applied after the end of the eighteenth century. The flesh tints of the angel with the trumpet contain fewer layers, the number varying from one place to another. We may assume that this angel has at times been partially overpainted, perhaps while left in place over the sounding board, the result being that some parts were difficult to reach and were therefore left unpainted.

The two tabernacles, as well as the shafts of the columns and pilasters, are now entirely covered with oil gilding. The other water-gilded surfaces have been preserved, although there has been much retouching with oil gilding and bronze paint. Many of the ochre parts in the gilded areas were overpainted once.

In summary, the decor as a whole has undergone major changes in color scheme: the backgrounds, initially pale blue, were changed to pink and then to white. Certain elements changed drastically in appearance: some gilded motifs were painted; others that had originally been painted are now covered in bronze paint; some elements initially painted black were repainted white. Most of the black and gilded elements underwent less obvious transformations: the black motifs were overpainted in matte black; the flesh tints were repainted in a cruder fashion; and the water-gilded surfaces were partially regilded in oil or were covered with bronze paint (Fig. 9).



*Figure 9*  
The statue of Saint Joseph and Child, in the upper niche of the main altarpiece. The angel heads on either side of the niche were originally painted with flesh tints.

---

## Treatment

### Surface consolidation

The old surface finishes—gilding and polychromy—were unevenly afflicted by problems of extensive lifting and flaking, which had increased over time. For example, the gilding on the frame of the high altar painting had flaked badly, while the surface on the capitals of nearby columns was much better preserved. Gilding made from a different formula, as well as the two layers of water gilding on the frame, may explain this phenomenon.<sup>10</sup> In other areas, water infiltration had caused the damage. Most of the cleavage was between the ground and the wood; therefore, the first task was the systematic consolidation of the lifted layers—which proved to be a long and arduous process.

Various methods and materials were considered for consolidation: animal glue, wax-resin mixtures, acrylic, and polyvinyl acetate (PVA). The goal was to find an adhesive that was simple and safe to use. On a job site where many of the tasks are performed on scaffolds, often in uncomfortable positions without an air evacuation system, it is essential to use a non-toxic adhesive that is easy to prepare, apply, and remove. The product would also need to retain its physical properties (good flexibility in particular) over the long term in order to accommodate the movements of the wood during summer-winter environmental changes. Animal glue does not have this elasticity.<sup>11</sup> Wax-resin mixtures have the great disadvantage of impregnating and darkening the matte colors, although one was used (unbleached beeswax mixed with dammar resin, 10:1) in the few instances where cupping required a gap filler between the ground and the wood. A few acrylics met these requirements,<sup>12</sup> but Jade 403, a polyvinyl acetate emulsion that is well known in the North American conservation community, was finally selected. The authors already had a great deal of experience with it, and a study undertaken at CCI confirmed its exceptional chemical and physical properties.<sup>13</sup> It is easily applied by brush, it can be thinned with water, and a little wetting agent can also be added to assist in penetration.<sup>14</sup> Since it contains water, it can soften the ground slightly and facilitate repositioning of the flakes.

### Surface cleaning

Concurrent with the surface consolidation, the surfaces were cleaned. First, dust and debris were removed with a brush and a vacuum cleaner. Then the water-sensitive surfaces were cleaned with Stoddard solvent, and other surfaces were cleaned with saliva or water with a wetting agent added.<sup>15</sup> This eliminated the accumulated dust, fly specks, and candle-wax accretions. A multitude of nails, pins, and miscellaneous fasteners were also removed during the cleaning process. The matting glue on the original gilding was retained, even though it had oxidized and become dust-laden. No overpaint was removed, because any aesthetic treatment was excluded from the first phase of the project.

### Wood consolidation

The joints, fastenings, and anchorings were systematically checked, and were reinforced if necessary. When practical, elements were remounted using stainless steel screws or other hardware that would allow for easy dismantling, both to facilitate future work and to ensure rapid disassembly in case of fire or other emergencies. Split and broken pieces were reglued

with hide glue or fish glue.<sup>16</sup> Pine additions, such as brackets, dowels, and inlays were made only when required for the solidity of the structure. When it was necessary to provide support for small surfaces, impregnation was performed with Jade 403, and fillings were made with fine oak sawdust mixed with Jade.

The main altarpiece had been attacked by wood-boring insects (*Anobium punctatum*). The four columns and their pedestals suffered damage, particularly columns 1 and 4 (numbered from left to right) (Fig. 2). The shafts are trunks of basswood, partly hollowed at the ends by the sculptor. Shaft 4 was so fragile that it no longer supported its gilded surface in many places; therefore it was imperative to stabilize the weakened wood. Column 4 had to be removed, and the column shaft was treated in the laboratory. Impregnation with Acryloid B72, a consolidant often used for degraded wood, was deemed impractical—first, because of the need to provide high mechanical strength for an element of considerable weight that supports the entablature; and, second, because problems were anticipated in evaporating such a large quantity of solvent. A large mass of wood partially sealed by gilding would require many consecutive applications of resin, interrupted with lengthy periods of evaporation. Araldite AY103,<sup>17</sup> a two-part epoxy, was chosen as an adequate alternative because of its long-term stability, low viscosity, moderate exothermic reaction, and fairly rapid polymerization (Down 1984). It was injected through small openings, taking maximum advantage of the access offered by splits and losses.

---

## Preventive Measures and Ambient Conditions

Long-term preservation of polychromed and gilded wood demands stable temperature and relative humidity conditions. The Ursulines were aware of this, and various preventive measures were discussed. However, investment in a climate control system for the building was felt to be an excessive option. The building is of masonry construction with double-paned windows; it is heated in the cold season by a network of hot-water pipes; and thermal insulation is present above the plaster vault. While imperfect, this system ensures a fairly regular temperature and prevents most abrupt changes in relative humidity. The months of July and August are a critical period, however, when rapid variations of relative humidity have been recorded. The seasonal transition in spring and autumn is gradual; relative humidity decreases in a fairly uniform manner, from an average of 60% in July and August to a level of 29% in January. The temperature ranges from 20 °C to 24 °C in summer, and is maintained between 22 °C and 24 °C as soon as the heating system is activated. A sophisticated system to control relative humidity might create disastrous situations in the event of a breakdown, and could trigger the swift deterioration of a building that was not designed to withstand a relative humidity of 40% or 45% in winter. Major modifications to the building would be necessary before installing humidity control. Simple preventive measures, such as lowering the chapel temperature a few degrees in winter months, should prevent most future damage to the polychromy and gilding.

The nuns remain in charge of maintenance of the premises and have implemented suggested preventive measures, which include improvement of the electrical system; installation of sprinklers, smoke detectors, and an alarm system; and UV filtration on the windows.

---

## Conclusion

The four-year preservation program of Canada's oldest church interior was a testing ground for large-scale treatment, as well as for analytical and historical research. Each day, comparing the results of examination, analysis, and historical research proved challenging and essential. For example, dendrochronology helped clarify conflicting attributions to artists.

Of major importance was the identification of both the traditional techniques used by the artists and artisans for this group of furnishings and the variations they introduced to these techniques. The original polychromy and gilding method may be summarized as follows: application on all visible surfaces of an animal-glue gesso ground, protected by a coat of size; followed by water gilding and water-based paint everywhere except the flesh tints, which were painted in oil; and, in order to obtain bright and resistant colors, application of a thin protective layer of size on all water-sensitive surfaces, except the large blue areas. It is possible that no size was ever brushed on the blue, presumably to blend the decor with the blue-painted walls of the chapel. Another possibility is that the blue surfaces had been sized but were later washed prior to being repainted, a theory supported by the fact that no layer of dirt was observed on top of the original blue paint.

Another reward of this project was the establishment of an inventory of the alterations (addition, modification, and removal) that had been made to the furnishings, hence providing a precise scheme of the original layout.

As mentioned earlier, various overpaints and regildings have altered the color and tonal balance of the decor. Most regrettably, the reconstruction work of 1902 compromised the original architectural plan and diminished the stylistic unity of the chapel's interior. The authors therefore believe that, to do justice to the furnishings of the chapel, the preservation work already undertaken must be followed by a second, development phase designed to restore the brilliance of the decor and part of the original contrast. This could involve major work in exposing original surfaces. Regarding the water gilding and flesh tints, tests indicate that the rather dull overpaints could be removed without damaging the original surfaces beneath. If the same cannot be reasonably done for the blue backgrounds and black moldings—whether because of the difficulty of uncovering matte, fragile, water-soluble paint layers or because of their lack of uniformity (variations in the blues)—it would be possible to simulate their colors and finishes by painting over the present overpaints. The missing forms, particularly the parts of repetitive architectural elements, such as the capital and frieze foliage, could be carved and finished to match existing elements. Furthermore, the colors of the walls and the vault could be modified to restore, to some degree, the original relationships of volumes and tones. The vault, for example, could be overpainted with a darker color to make it appear lower. Artificial lateral lighting could be used to simulate the original daytime atmosphere.

The decisions on this possible second phase are yet to be made. The Ursuline nuns will make the final decision on the nature and extent of treatment, based on recommendations made by the advisory committee. The authors believe that the extensive research and preliminary treatment that has been done since 1988 will help to demonstrate the importance of continuing work to preserve this treasure of the cultural heritage.

---

## Acknowledgments

The authors thank Michel Cauchon, director of the Centre de conservation du Québec (CCQ), and Gérard Lavallée, Guy-André Roy, and Jean Trudel, art historians, for their support and related research during this project. They are also indebted to sisters Rita Coulombe and Jacqueline Fortier of the Order of Saint Ursula, and the members of the convent council and the Ursuline museum. Gratefully acknowledged is the assistance of the conservators who took part in the project: Fiona Graham, Claire Pichot, Nora Nagy, Anne Courcelle, Jacques Vereecke, Sandrine Barbe, Anne Lapointe, Isabelle Paradis, Jean-Pierre Thibaut, Philippe Fèvre, Bernard Vallée, Patrick Albert, Jérôme-René Morissette, Aubert Gérard, Jean-Albert Glatigny, Anne-Sophie Augustyniak, Désy Fischer and Ariane Segelstein. Special thanks is due to David Miller and Greg Young, conservation scientists at the Canadian Conservation Institute (CCI). Appreciation is also extended to photographers Michel Elie and Jacques Beardsell, to draftsman Danielle Filion, and to all colleagues at CCQ and CCI who helped in the editing of this article.

---

## Notes

- 1 The *altarpiece* (*retable*, in French) is the architectural furnishing that covers the wall behind the altar; it usually contains statues and a painting. The *tabernacle* is the elaborate gilt eucharistic reserve that sits on the altar table. The *altar* consists of both the tabernacle and the table, and it stands in front of the altarpiece.
- 2 On the history, style, and iconography of the chapel, see Trudel 1972.
- 3 The Ursulines operated a gilding workshop from around 1650 until 1828. They were the first in New France to engage in such an activity and progressively transmitted their expertise to many other communities.
- 4 Micro-mesh grades 1500 to 12000.
- 5 The CEN researchers have established reference series for a few Quebec conifers: tamarack (*Larix laricina*), black spruce (*Picea mariana*), white spruce (*Picea glauca*), white pine (*Pinus strobus*), Canadian hemlock (*Tsuga canadensis*), and Eastern cedar (*Thuja occidentalis*). This technique has, as yet, been little used in Canada in the arts.
- 6 In most cases, the FT-IR analysis did not permit a more precise identification of the protein medium. However, in some samples, the proteinaceous medium was further characterized as a collagen-type protein, such as rabbit-skin or bone glue.
- 7 A thin white layer containing lead white and lead carbonate in a drying oil is also present immediately under the layer of blue paint, in some of the parts originally painted blue.
- 8 Jo Kirby plans to undertake research to investigate the phenomenon of the greening of Prussian blue.
- 9 This conclusion is supported by various lists of shipments to the Ursulines in the 1720s and 1730s (Archives des Ursulines de Québec 1680–1755, 1682–1761), in which *vermillon* (vermillion) is mentioned several times. These lists include other materials related to painting and gilding, such as *noir de fumée* (lampblack), *safran* (saffron), *ocre jaune* (yellow ochre), *ocre rouge* (red ochre), *terre d'ombre* (umber), *blanc de céruse* (lead white), *blanc de litharge* (litharge), *sanguine* (sanguine), *gomme arabique* (gum arabic), *rognure de parchemin* (parchment clippings), *rognure de gant* (glove clippings), *blanc d'Espagne* (calcium carbonate), and *craie blanche* (white chalk). There is no reference in the shipment lists to Prussian blue, but *cendre bleue* (azurite) is repeated many times. *Azur* (lapis lazuli) is also mentioned occasionally. It can be assumed that Prussian blue, a recent discovery at that time, was sent from France as a substitute for traditional, more expensive blue pigments.
- 10 The frame of the high altar painting is the only element that has been regilded with water gilding. Close examination shows that the altarpiece may originally have been designed to accommodate an older framed painting.

- 11 Rabbit-skin and fish glues are sometimes used for surface consolidation on sculptures that are kept in controlled environments.
- 12 The following acrylic adhesives were considered: Rhoplex AC-33, Plextol B-500, and Lascaux 498HV (see Materials and Suppliers).
- 13 The study, conducted by Down et al. 1992, covered the following characteristics of various resins, in natural aging: pH, volatile emission, yellowing, and flexibility (modulus of elasticity, elongation at break, cohesive tensile strength). The report states that Jade is actually a vinyl acetate copolymerized with ethylene.
- 14 The stock solution of Jade 403 was thinned 1:1 with water in small (30 ml) bottles, and a drop of wetting agent was added to each bottle. The wetting agent was Aerosol OT solution, 75% (w/w) aqueous (see Materials and Suppliers).
- 15 Aerosol OT solution (see note 15) was added to tap water. Saliva was preferred to water in cases of small and intricate surfaces that were sensitive to a wet cotton swab. It is easier to adjust the moisture content of a swab with saliva, and saliva is somewhat more active than water, which often proves useful.
- 16 When a long setting time was necessary for fine adjustment, liquid fish glue (sold as high-tack fish glue) was used undiluted at room temperature. In most cases, however, hide glue (no. 135 grade hide glue—4 parts glue in 5 parts water) was the first choice; it must be heated and sets rapidly but allows for some adjustment. Glue was chosen rather than acrylics or other synthetics, as it was compatible with any residue of old glue that might remain even after cleaning the surfaces.
- 17 Araldite AY103 resin, with H956 hardener, was mixed in batches of 200 g, and was preheated to 45 °C to start the reaction; then 20 g of acetone (10%) was added to further lower its viscosity. Only a small amount of resin was injected in an opening at any given time, to prevent any buildup of temperature. Polymerization was complete in less than twenty-four hours. Other epoxies were considered, such as Epo-Tek 301-2, which is more fluid than the AY103 but which takes days to polymerize, making large-scale impregnation impracticable.

---

## Materials and Suppliers

**Acryloid B72**, Rohm and Haas Co., Independence Mall Street, Philadelphia, PA 19105.

**Aerosol OT solution**, Fisher Scientific Ltd., 112 Colonnade Road, Nepean, Ontario, K2E 7L6, Canada.

**Araldite AY103 resin, with H956 hardener**, Ciba-Geigy Canada Ltd., Polymers Division, 7030 Century Avenue, Mississauga, Ontario, Canada, L5N 2W5.

**Epo-Tek 301-2**, Epoxy Technology Inc., 14 Fortune Drive, Billerica, MA 01821-3972.

**Jade no. 403**, TALAS, Technical Library Services Inc., 213 West 35th Street, New York, NY 10001-1996.

**Lascaux 498HV**, Lascaux Farbenfabrik, Riedmuhlestrasse 19, Bruttiselem, Switzerland.

**Liquid fish glue**, Norland Products Inc., 695 Joyce Kilmer Ave., New Brunswick, NJ 08902. Sold as high-tack fish glue by Lee Valley Tools Ltd., 1080 Morrison Drive, Ottawa, Ontario, K2H 8K7, Canada.

**Micro-mesh grades 1500 to 12000**, Micro-Surface Finishing Products Inc., 1217 West Third Street, Wilton, IA 52778.

**No. 135 grade hide glue**, Bjorn Industries Inc., 551 King Edward Road, Charlotte, NC 28211.

**Plextol B-500**, Rohm and Haas Germany Ltd., Postfach 4242, Kirchenallee, D-6100 Darmstadt, Germany.

**Rhoplex AC-33**, Rohm and Haas Canada Inc., 2 Manse Road, West Hill, Ontario, M1E 3T9, Canada.

---

**References**

- Archives des Ursulines de Québec  
 1682–1761 Temporel, affaires de France, Envois de marchandises, factures et connaissements [Canadian archive].
- 1680–1755 Temporel, affaires de France, Envois de marchandises, mémoires [Canadian archive].
- Delwaide, A., and L. Fillion  
 1993 *Analyse dendrochronologique de deux pièces de bois provenant du tabernacle latéral de la chapelle des Ursulines, Ville de Québec*. Québec City: Laboratoire de dendrochronologie, Centre d'études nordiques, Université Laval.
- 1994 *Analyse dendrochronologique de neuf pièces de bois provenant du retable principal de la chapelle des ursulines, Ville de Québec*. Québec City: Laboratoire de dendrochronologie, Centre d'études nordiques, Université Laval.
- Down, J. L.  
 1984 The yellowing of epoxy resin adhesives: Report on natural dark aging. *Studies in Conservation* 31:159–70.
- Down, J. L., M. A. MacDonald, J. Tétreault, and R. S. Williams  
 1992 *Adhesive Testing at the Canadian Conservation Institute: An Evaluation of Selected Poly(vinyl acetate) and Acrylic Adhesives*. Environment and Deterioration Research Report No. 1603. Ottawa: Canadian Conservation Institute.
- Feller, R. L.  
 1986 Barium sulfate: Natural and synthetic. In *Artists' Pigments: A History of Their History and Characteristics*, ed. R. L. Feller, 47–64. Washington, D.C.: National Gallery of Art.
- Kirby, J.  
 1993 Fading and colour changes of Prussian blue: Occurrences and early reports. *National Gallery Technical Bulletin* 14:63–71.
- Porter, J. R.  
 1975 *L'art de la dorure au Québec*. Québec City: Editions Garneau.
- Townsend, J. H.  
 1993 The materials of J. M. W. Turner: Pigments. *Studies in Conservation* 38:231–54.
- Trudel, J.  
 1972 *Un chef-d'oeuvre de l'art ancien du Québec, La chapelle des Ursulines*. Québec City: Les presses de l'Université Laval.
- Watin, J. F.  
 1773 *L'art du peintre, doreur et vernisseur*. 2d ed. Paris: Grangé Durand.
- Welsh, F. S.  
 1988 Particle characteristics of Prussian blue in an historical oil paint. *Journal of the American Institute for Conservation* 27:55–63.



# The Painted Tester Bedstead at Agecroft Hall

*Elizabeth Howard Schmidt*

IT IS NOT SURPRISING that so little early English painted furniture exists today, considering the fragile nature of painted surfaces and the vagaries in taste. Understandably, therefore, the elaborately carved and painted tester bedstead at Agecroft Hall (ca. 1580–1630) (Fig. 1), and its companion painted chest of drawers (ca. 1650–75) (Fig. 2), have created much interest both here and abroad.<sup>1</sup>

The Agecroft Association purchased the bed in 1974 at an auction on the grounds at Burderop House, Wiltshire, England. The chest of drawers, sold at the same auction to a private collector, was purchased by Agecroft in 1978.

With the assistance of a team of specialists, Agecroft began a research project in 1994 in an attempt to resolve many of the questions concerning the painted tester bedstead (a rare example of early English painted furniture): How and when was the bed constructed and what alterations have been made to it over the centuries? What are the carved decorative motifs on this unusual bed, and how do they relate to styles of the period? How was the bed originally finished, and when was it polychromed? How do the form and painted decoration of the chest of drawers relate to the bed? Finally, how does the bed relate to the early-seventeenth-century wall paintings found in the southeast bedroom of Burderop House in

*Figure 1*

Painted tester bedstead (ca. 1580–1630) from Burderop House, Wiltshire, England, now at Agecroft Hall, Richmond, Virginia.

*Figure 2*

Painted, joined chest of drawers (ca. 1650–75) at Burderop House, Wiltshire, England, a companion to the painted tester bedstead at Agecroft Hall.



Wiltshire, England? This article examines available evidence and confirms a date of the late sixteenth or early seventeenth century for the painted bedstead, and shows that Burderop House was probably the original setting for the bed and its companion chest of drawers.

---

## Bedstead

### Construction and alterations

The form of the Agecroft bed is typical of sixteenth- and early-seventeenth-century English tester bedsteads that belonged to the middle and upper classes of society. A great bed, furnished with rich textile curtains and coverlets, was usually the owner's most important possession. Rarely was there more than one elaborately decorated bed in a house.

Predominantly oak, the Agecroft bed is constructed in several sections—bedstock, headboard, tester, and two main footposts of six parts each. Although little is known about construction practices in this era, furniture such as the Agecroft bed, made by country joiners, was generally constructed with materials purchased “off the peg” (e.g., precarved molding) or with materials supplied by the owner (Chinnery 1979:48–50).

Each rail of the bedstock is attached by a mortise-and-tenon joint to the headboard. It is somewhat unusual that the foot of the bedstock, which has its own low, freestanding footposts with turned finials, is also tenoned to the main footposts supporting the tester. Tester bedsteads of this period had turned wooden stakes, known as *bedstaves*, placed around the bedrails to prevent the many layers of bedding from slipping onto the floor. The bedstaff holes, each 2.54 cm (1 in.) in diameter and 5.08 cm (2 in.) deep, are still visible along the top of the footrails on the Agecroft bedstock.

Changes made through time to the bed are significant in establishing a date. Most of these changes were made to the bedstock. The original support for the bedding was roping, attached to the bedstock on all four sides. Later, the bedstock was lowered 17.78 cm (7 in.), and the rope holes on the bed rails and the lower headboard were plugged and painted over. Presumably, at that time, a canvas support for the bedding was attached to the bedrails. Beneath the present canvas support, attached to the bedstock with nineteenth-century cut nails, are the cutoff remains of earlier forged nails.

When the bedstock was lowered, the bottom register of the headboard became more visible (Fig. 3). On tester bedsteads of the period, the lowest register usually was not decorated because the occupants slept propped on large bolsters and pillows (due to the belief that it was unhealthy to sleep lying down); therefore, this area would not be visible. The lowest register of the Agecroft bed, however, has a series of four arched panels carved in low relief, which are blue and white with a red-grained paint background. This red graining, covering the now visible plugged rope holes, indicates that the bed was painted after the bedstock was lowered. Household inventories indicate that canvas-supported bedsteads existed concurrently with roped bedsteads from the sixteenth century;<sup>2</sup> therefore, the conversion from roped to canvas support could have occurred early in the bed's history.

### Decoration

Much of the charm of English furniture of this period is the unique character of each piece. Scholars have cited numerous Continental designers,

Figure 3

Detail of the headboard. The red graining and plugged rope holes on the lowest register provided clues to dating the paint.



including Hans Vredeman De Vries and Jacques Androuet Ducerceau, who produced pattern books in the sixteenth century as sources for the decorative vocabulary in English Renaissance architecture and furnishings (Wells-Cole 1981; Forman 1971). Certainly there are elements, including architectural motifs, terminal figures with baskets of flowers on their heads, and fantastic animals, that obviously derive from these sources. It is very unlikely, however, that a provincial artisan such as the carver of the Agecroft bed would have seen the pattern books in their original form. The carver, therefore, must have created another version of these exotic motifs.

The main register of the Agecroft bed has a decorative scheme that is seen frequently on overmantels, chests, and beds of the period. Three terminal figures are depicted: a dark-skinned male on each side and a fair, blond female in the center. Each figure terminates in an elaborate shield, decorated with a stylized, carved animal face (Fleming, Honour, and Pevsner 1976:283).<sup>3</sup> Three identical white baskets of stylized, pink fruitlike flowers with green leaves rest on the heads of the figures.

The two inset panels on the main register, framed by green acanthus leaves, contain arches supported by pairs of facing lions (smiling and winged), an ancient motif of heraldic symmetry.<sup>4</sup> Beneath the arches, a pair of inner panels depicts carved, stylized pink carnations in various stages of flowering. Although stylized flowers were often used in arched panels on furniture and other carved or inlaid decoration, these flowers have no known exact parallel.

An interesting feature on almost all beds of this type is the presence of satyr figures somewhere on the headboard. Could this ancient symbol of lust be reinterpreted here as a symbol of fertility? The satyrs on



Figure 4  
Detail of a 1640 joined armchair (illustrated in Chinnery 1979:457, 86, fig. 4).



Figure 5  
Detail of winged red-haired man with black mustache and blond beard from the Agecroft bed, underside of the valance.

## Chest of Drawers

the Agecroft bed rest on a cornice on each side of the main register. They have pointed ears, blond hair, large black eyes, red lips, and no arms. Their legs and hooves are like those of a goat, with carved and detailed, brown-painted hair on the flanks. Around each of their waists is a black belt with a curious rectangular-shaped boss on the front. The figures are finished only on the front and one side, indicating that they were carved as a flanking pair.

The third and top register of the Agecroft headboard depicts two large, green sea monsters with pointed white teeth, each one swallowing a fish. The heads of the two monsters are joined in the center of the bed by a carved tasseled cord. Each tail ends in a spiral attached to a red rosette that has been cut in half at each end of the panel.

A headboard quite similar to the Agecroft example is on the Great Bed of Ware, now at the Victoria and Albert Museum in London. This oversized bed, almost 3.35 m (11 ft.) square, has been the subject of much speculation since it was mentioned in Shakespeare's *Twelfth Night*, first performed in 1601 (Thornton 1976).<sup>5</sup> The terminal figures on the Great Bed of Ware are very similar to the Agecroft examples. The beds differ in that the figures (including the satyrs) on the Great Bed of Ware are painted, whereas the rest of the bed is unpainted.

Like the sea monsters on the third and top register of the headboard of the Agecroft bed, the fire-breathing, interlocking dragons on the valance have spiral tails attached to red rosettes, and their heads are joined by a short cord.<sup>6</sup> Victor Chinnery, an authority on English oak furniture, notes that these particular animal decorations on the Agecroft bed are typical of certain decorative elements found primarily in southwest England, where Burderop House is located. Indeed, the motif of paired dragons with spiraling tails is a consistent feature on the crests of Gloucestershire chairs (Fig. 4).<sup>7</sup>

The winged figures in the four corners of the underside of the tester are probably the most striking and unusual decoration on the Agecroft bed (Fig. 5). They are realistic male heads with flowing, flaming red hair, black mustaches, and short blond beards. The use of the tasseled cords and the technique of the carving suggest that the sea monster sections, the dragons on the valance, and the winged figures were carved by the same person. The traditional guilloche and acanthus-leaf decoration on the main footposts is less imaginative than the carving elsewhere on the bed. The footposts are somewhat atypical, however, in that each has two large bulbous turnings rather than the usual massive plinth surmounted by posts with a single bulbous turning.<sup>8</sup>

Early-nineteenth-century documents from Burderop House list a painted chest of drawers in association with the painted bed. The chest is made in two sections with an assortment of wood—oak, walnut, elm, and pine—which leaves little doubt that it was intended from the beginning to be painted (Chinnery 1979:90–91, 207, 209). Although the chest is painted in a naive and cursory manner compared to the bed, the motifs—terminal figures, flower panels, and the barely visible tasseled cord between sea monsters—are obviously taken from the bed.

Although the form of the Agecroft chest of drawers is typical for the third quarter of the seventeenth century, many questions remain regarding the piece. From a purely visual examination, it is impossible to

determine the relative dates of the bed and the chest of drawers. A paint analysis in conjunction with a thorough structural study of the chest of drawers will help to provide insight into this question.

---

## Paint Analysis of the Bed

The form of the Agecroft painted bed, its construction, and its decorative elements all suggest a late-sixteenth- or early-seventeenth-century date of fabrication. However, questions remain about the original finish and the age of the current polychromy. To better understand the surface history, Agecroft conservator, Sandy Jensen, and Colonial Williamsburg conservator Carey Howlett took small samples from various locations and made a preliminary microscopic analysis. James Martin, director of Analytical Services and Research at Williamstown Art Conservation Center, carried out additional microscopy and chemical analysis of selected pigments and binders. Martin analyzed samples using four microscopic techniques: stereomicroscopy, polarizing light/fluorescence microscopy (PLM/FM), Fourier-transform infrared (FT-IR) microspectroscopy, and scanning electron microscopy with energy-dispersive spectrometry (SEM-EDS).<sup>9</sup>

The stratigraphy of paint layers and coatings was first determined by examining samples in cross section. This layering was then related to paints and clear coatings present on a section of detached headboard molding. Minute samples were taken from the molding for analysis of specific pigments, coatings and binders.

The analysis revealed three historic decorative treatments that remained largely intact on most of the bed's surface: (1) an early transparent amber-colored varnish; (2) a thin layer of red paint; and (3) a more complex layering, involving a base coat of red paint, a graining glaze, and polychrome details (Martin 1995).<sup>10</sup>

### The wood substrate and amber-colored varnish

In sample cross sections, the wood fibers adjacent to the early coating appear very dark, suggesting oxidation due to prolonged exposure to light and air. The amber-colored coating itself appears to be a tree resin, probably pine rosin (Martin 1995).<sup>11</sup> Though probably transparent when applied, it is now yellowed, somewhat discontinuous, and heavily fissured, typical of an aged coating. The oxidation of the wood suggests that the components of the bed may have remained unfinished for some time after their construction, then received a thin coating of transparent varnish. The poor condition of the varnish indicates that it served as the finish coat for many years prior to the application of paint. Carved elements support the hypothesis that the bed's maker intended the natural oak to be the show surface. The carver employed decorative punch work in the ground areas to heighten the contrast between the ground and the raised carvings. Such work is both unusual and unnecessary on surfaces designed to receive polychromy; painted contrasts are far simpler to achieve yet more dramatic in effect.

### The thin layer of red paint

The earliest pigmented layer is a thin red paint applied directly above the deteriorated varnish (sample cross sections reveal the paint flowing into fissures in the old resin layer). The paint consists of red iron oxide and lead white in a protein binder (Martin 1995).<sup>12</sup> This layer was applied after the

bedrails were lowered and the mattress support was changed from a rope to a canvas support; the thin red paint is the earliest layer found on the wooden plugs that fill the original rope holes.

### The final decorative treatment

The polychromy currently visible on the bed is the third (and final) decorative scheme. It is considerably more complex than the earlier coatings and consists of an ochre-colored base coat, two red-graining layers, polychromed details, and a final coat of varnish. The ochre-colored layer, composed of lead white and red iron oxide in oil, serves as the primer for the green, blue, black, red, and white elements, but it also appears as the visible ochre layer in many areas. The two red-graining layers were applied above the ochre and consist of a lower opaque layer of red lead, hematite, yellow iron oxide, and lead white (or litharge); and a transparent upper layer composed of red lake. The upper layers of polychromy await further analysis but include a blue made from lead white, indigo, and smalt in an oil binder. The varnish above this decorative scheme has been characterized as a tree resin—possibly copal (Martin 1995).<sup>13</sup>

### Dating the three paint schemes

The date of application for each of the three decorative schemes remains somewhat conjectural. The initial resin coating may have been applied within a few years after the elements of the bed were carved—in the late sixteenth or early seventeenth century. The second scheme—the thin red layer—was obviously applied after the bed support was converted from rope to a canvas support. This alteration occurred as early as the mid-seventeenth century, a date consistent with the forged nails associated with the canvas support and the materials used in the red paint. The final polychromatic scheme was certainly applied a good while after the bed was made, as indicated by the weathered, deteriorated condition of the earlier coatings; however, all of the materials thus far identified (pigments, binders, and varnish) were in use in the 1600s, and it is conceivable that this decorative scheme dates from late in that century. Further analysis may provide more conclusive information about the age of the polychromy.

---

### Burderop House: The Original Setting for the Bed and Chest of Drawers?

The unexpected discovery in 1978 of early-seventeenth-century wall paintings—during extensive alterations to Burderop House, where the bed and chest of drawers were acquired—may be significant in tracing the history of the pieces (Fig. 6).

The manor of Burderop existed as early as the fourteenth century under the holdings of the Abbot of Hyde. The Stephens family owned Burderop from the early sixteenth century until trustees for Thomas Stephens (IV) sold the house in 1619 to William Calley I, a wealthy Londoner with court connections. Documents indicate that a “new . . . Mansion howse” had been built on the property shortly before Calley’s purchase; however, nothing is known of changes made to the house after he became the owner.<sup>14</sup> A drastic reconstruction in the Georgian style, both interior and exterior, took place in 1730, leaving little evidence of the earlier structure. When the present owners of the house undertook renovation in 1978, the removal of eighteenth-century paneling unexpectedly revealed wall paintings in four of the first-floor rooms.<sup>15</sup>

Figure 6  
Photomontage of seventeenth-century wall painting, west wall of southeast room at Burderop House, Wiltshire, England.

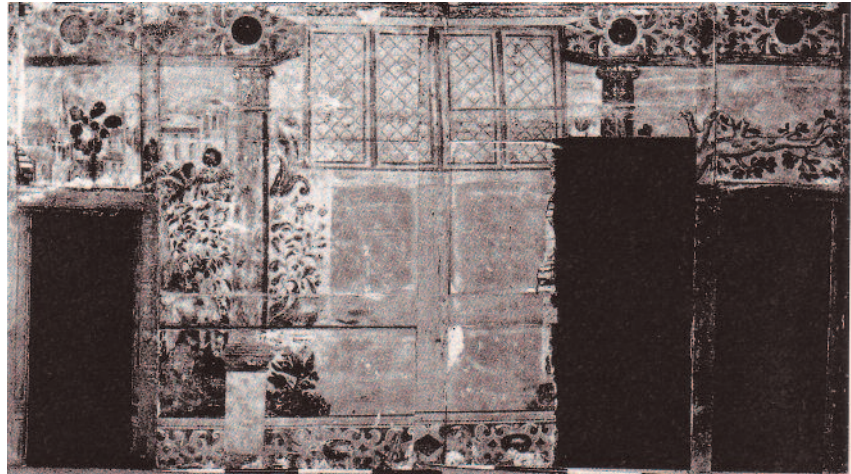

The most complete wall paintings were found in the southeast bedroom, covering the west and the north walls. They depict a stylized landscape with animals, foliage, and buildings, divided by trompe l'oeil columns. An integral part of the decoration is the coat of arms of William Calley I painted above the fireplace on the north wall. This coat of arms is evidence that the wall paintings were applied sometime between 1619, when Calley acquired the house, and before his death in 1641.

The leaded-glass casement window, painted in the trompe l'oeil style in the center of the west wall, is strangely out of context with the landscape scene. The large blank area beneath this window measures approximately 173 cm by 208 cm, the same dimensions as the headboard of the Agecroft tester bed. An image of an earlier wall painting is barely visible beneath the surface of the blank area. This trompe l'oeil painting, depicting lozenge-shaped paneling, may have been the original setting for the painted bed, if a pre-1619 date for the bed is correct.<sup>16</sup>

Although the form and decoration of the Agecroft bed appears to be from an earlier date than the style of the more sophisticated wall painting at Burderop House, there can be little doubt that the wall painting was planned to surround a bed the same size as the Agecroft bed. The bed would have been placed in the center of the wall beneath the painted window. The wall paintings were designed to accommodate the doors at the extreme left and right of the wall. A second door on the right was inserted later, destroying most of the painted column and the foliage on that side.

A search for documents that refer to the painted bed and the painted chest of drawers has revealed little information. The earliest documented evidence of the presence of the pieces in Burderop House is an 1824 inventory of the contents. By that time, the bed and chest of drawers had been banished to the attic. They were located in room 21, which is listed as the "Image Attic." The bed is described as the "Image Bedstead," and the chest of drawers as "painted drawers with Key." The word *imaging*, an old term for painting and carving, suggests that the name had been attached to the bed early in its history.<sup>17</sup> According to an 1829 inventory, the bed and chest of drawers were still in the attic; however, the bed is described as the "Carved bedstead," while the chest of drawers is described as "painted Drawers and Key."<sup>18</sup>

The last nineteenth-century reference to the presence of the pieces in Burderop House is the 1882 inventory, which lists an "Antique

Four post Bedstead” and an “Antique Chest Drawers” in the “Blue Bed Room.”<sup>19</sup> By this time, it appears that the bed and chest of drawers were returned to the first floor, possibly because of the late-nineteenth-century taste for Elizabethan and Jacobean furnishings. Correspondence in the file at Agecroft from the time of the 1974 auction states that the bed was slept in until the time of the sale.<sup>20</sup> The surviving relative, Sir Henry Langton, is quoted as stating that the bed and chest of drawers had been at Burderop House for many years, probably from the time the pieces were made (Warner 1974).<sup>21</sup> One may conclude that this statement is true, given the evidence from the nineteenth-century inventories and the bed’s association with the early-seventeenth-century wall painting described here.

The painted tester bedstead at Agecroft Hall should be recognized as an extremely rare example of early English painted furniture. The form and construction of the bed and its decorative motifs are typical of the period and support the circa 1580–1630 date. Evidence from the bed’s finishes does not contradict the proposed date. The paired dragon motif on the valance ties the bed to the southwest of England, the site of Burderop House, whose inventories from 1824, 1829, and 1882 link the painted chest of drawers and painted tester bedstead and place them together in the house. Wall paintings applied between 1619 and 1641 in the southwest bedroom reveal a space that is the same approximate dimension as the bed’s headboard, suggesting that Burderop House was the original setting for the bed.

The Agecroft painted tester bedstead and its companion painted chest of drawers are worthy of further investigation. Research and paint analysis are ongoing on both of the pieces. A more thorough search of Burderop House family papers is being conducted to document the house as the original setting for the bed and chest of drawers. Continued research on the wall paintings may throw new light on their relationship to the painted tester bedstead.

---

## Acknowledgments

The author wishes to acknowledge a number of people without whose assistance this project would not have been possible: conservators F. Carey Howlett and Sandy Jensen, who spent many hours examining the bed and the paint samples; scientist James Martin, who provided the information for the paint analysis section; and Margaret Taylor, who advised on the organization of this article. The staff at Agecroft Hall, Richmond, Virginia, has been an invaluable help, especially the curator of collections, Mary Anne Caton, and trustee Jane Paden. The Agecroft Association provided office support and the funds for the paint analysis of the bed and chest of drawers. In England, Victor Chinnery assisted and advised the author throughout this project. The staff of the Wiltshire County Council Conservation Laboratory, Frances Collard of the Furniture Department at the Victoria and Albert Museum, Nick Molyneux of English Heritage, and genealogist Pat Hughes have provided much useful information.

---

## Notes

- 1 Agecroft Hall is a Tudor period house that was moved from Lancashire, England, to Richmond, Virginia, in the 1920s. It is now a museum furnished with a collection of English Tudor and early Stuart furnishings. The term *tester bedstead* is found in contemporary inventories; however, it is used interchangeably with the word *bed* throughout this article. *Tester* comes from the Latin *testa*, meaning covering.



- 2 Chinnery (1994a) substantiates that these means of support existed concurrently: "In sixteenth and seventeenth century inventories 'corded bedsteads' and 'canvas-bottomed' or 'sacking-bottom bedsteads' are found very much in parallel."
- 3 These human figures, the bottom halves of which end in pedestals, are called *terms*. Some authors refer to these figures as *atlantes* (male) and *caryatids* (female).
- 4 It is quite curious that the pair of lions on the proper left have the remains of what appear to be wooden dowels clenched between their teeth, and there are similar holes in the mouths of the other lions, where dowels would have been.
- 5 The reference to the bed speaks of a sheet "big enough for the bed of Ware" and appears in act 3, scene 2 of the play. The decorative scheme on the headboard is the same as the Agecroft example, except that the Great Bed of Ware, which is more refined in workmanship, has the female figure placed on the proper right side and not, as usual, in the center between two males.
- 6 The dragon panels appear to have been carved to fit this bed and are mitered at the corners.
- 7 There are comparable dragons over a stone doorway at University Farm House in the village of Moreton-in-Marsh, Gloucestershire, near Burderop House (Chinnery 1994b).
- 8 Other examples of footposts similar to those on the Agecroft bed are the well-documented bed at Montacute House, a bed at Athelhampton House (recently destroyed by fire), and the bed in the Rupert Room at Sudeley Castle.
- 9 Polarized light/fluorescence microscopy (PLM/FM) was performed at Colonial Williamsburg and at the Williamstown Center using an Olympus BH-2 polarizing light microscope equipped for epi-fluorescence illumination. Fourier-transform infrared (FT-IR) microspectroscopy was performed at the Williamstown Center using a Spectra-Tech IR Plan Research microscope coupled with a Nicolet Magna 550 optical bench; samples were prepared neat on Spectra-Tech diamond cells and analyzed for 32–512 scans at  $4\text{ cm}^{-1}$  using Happs-Genzel apodization. Scanning electron microscopy with energy-dispersive spectrometry (SEM-EDS) was performed by the Williamstown Center using a Cambridge Stereoscan 100 SEM equipped with a Tracor (now Noran) EDS detector; samples were mounted on aluminum stubs, carbon coated for conductivity, and analyzed at 15–25 kV.
- 10 See also the chapter by Martin in this volume.
- 11 The coating, characterized by FT-IR, is rapidly soluble in acetone, causing later layers to release from the wood and presenting certain problems for solvent treatment of the bedstead.
- 12 The protein binder was characterized by FT-IR, and the pigments by PLM/FM.
- 13 Binders and coating were characterized by FT-IR; pigments were identified using PLM and SEM-EDS.
- 14 Pat Hughes in an unpublished manuscript, "The History of Burderop House," document 4, WRO 1178/38. Agecroft Hall.
- 15 The wall paintings, which were removed from Burderop House in 1978, are in the Wiltshire County Council Conservation Laboratory, where they are currently being treated.
- 16 Hughes, "Burderop House," document 8, WAM xxx 141/2. One can only speculate as to when the bed came to Burderop House. However, due to the apparent mental instability of Thomas Stephens (IV), the house was sold to Calley by trustees, and Stephens died in 1631 in the house of friends. It is certainly possible under these circumstances that furnishings were sold with the house.
- 17 Hughes, "Burderop House," document 4, WRO 1178/53. The items listed in the inventory indicate that these second-floor attic rooms were furnished for use and were not simply storage areas.
- 18 Hughes, "Burderop House," document 5, WRO 1178/53.
- 19 Hughes, "Burderop House," document 6, WRO 1178/411/3.

- 20 Further evidence of the bed's antiquity and importance is the exemption of the bed from death duties when the contents of the house were assessed upon the death of Major General Charles Pleydell Calley on 14 February 1932.
- 21 Warner quotes Sir Henry Langton, nephew of the late Miss Calley.

---

## References

- Chinnery, V.  
1979 *Oak Furniture, The British Tradition*. Woodbridge, England: Antique Collectors' Club.
- 1994a Letter to Curator of Collections, Mary Anne Caton. Agecroft Hall, 7 August.
- 1994b Telephone conversation with the author, 16 September.
- Fleming, J., H. Honour., and N. Pevsner  
1976 *The Penguin Dictionary of Architecture*. Harmondsworth, England: Penguin Books.
- Forman, B.  
1971 Continental furniture craftsmen in London, 1511–1625. *Furniture History* 7:1–120.
- Martin, James  
1995 Analysis of samples from the Agecroft Hall bed. Report, October, Williamstown Art Conservation Center.
- Thornton, P.  
1976 The Great Bed of Ware. Victoria and Albert Museum Masterpieces, Sheet 8. Victoria and Albert Museum, London.
- Warner, R.  
1974 Letter to John Williams, Director, Agecroft Hall, 24 May.
- Wells-Cole, A.  
1981 An oak bed at Montacute. *Furniture History* 18:1–19.

## Four Japanned Cabinets: A Variety of Techniques

Marianne Webb

THE PREPARATION FOR THE OPENING of the second wing of European Decorative Arts at the Royal Ontario Museum has afforded the conservators and curators the opportunity to examine in detail many of the japanned pieces in the collection. This furniture has been in storage for many years because some of the pieces were considered unexhibitable due to their poor condition.

The type of japanning evidenced on these cabinets first became popular in the seventeenth century, as contacts with the Far East through the Dutch East Indies Company and the East India Company became more frequent. As the popularity increased, the demand could not be met by Asian lacquerwares alone. Early attempts to import the raw lacquer and to cultivate the trees that produce it failed, and, although it was being imported to England by the mid-eighteenth century, it was considered too dangerous for common use. Robert Dossie writes in *The Handmaid to the Arts* (1764:408), "Its poisonous qualities are almost constantly fatal to those who work with it any length of time and sometimes even on very slight meddling with it." New formulas were developed to produce a hard lustrous surface. This collection of four cabinets demonstrates several different techniques of japanning in use during the seventeenth, eighteenth, and nineteenth centuries.

---

### English Seventeenth-Century Cabinet

This is a typical late-seventeenth-century japanned cabinet on an elaborate silver gilded stand (Fig. 1). Prior to examination by conservators, this cabinet was believed to be wholly from the seventeenth century; however, suspicions were first aroused when this piece was seen in good lighting. The exterior was severely damaged (Fig. 2), while the interior retained a smooth, refined surface (Fig. 3). The protection afforded by the closed doors was not sufficient to explain the drastic difference in condition. Also, under ultraviolet light the interior and exterior surfaces had their own distinct fluorescence. It was clear that the cabinet had been refinished, probably during the nineteenth century.

The cabinet was originally finished with a traditional European japanning technique, using shellac or seed lac as the resin. The decoration was completed by suspending gold and other metals within the layers of shellac. In some areas the metal powders appear to have been applied using a sprinkling technique, while in other areas the metal appears to have been mixed up as a paint, then applied. The molding between the



Figure 1  
English japanned cabinet, dated 1695, as it appeared shortly after restoration in 1960.

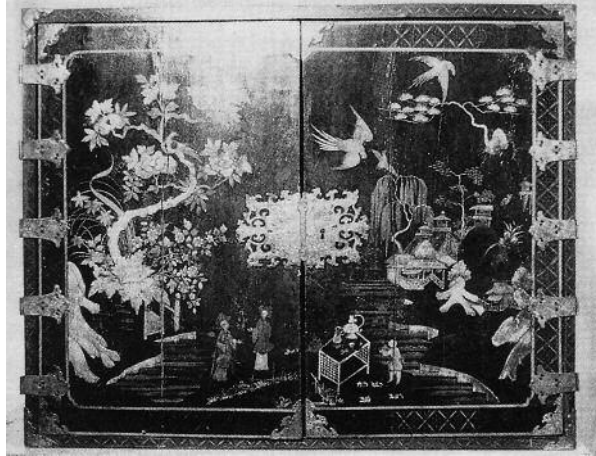

Figure 2  
Front of the cabinet, showing the deteriorated state of the nineteenth-century finish. Note long vertical cracks through each door.

drawers and the interior of the drawers were speckled. The random distribution of the speckling suggests that the powders were applied by sprinkling, as opposed to brushing. The interior and exterior had been finished in a similar manner, except that there were also areas of raised decoration applied on top of the black shellac finish of the doors.

The designs are typical of the chinoiserie of the period, exhibiting Chinese landscapes, figures, and birds. While they are not exact reproductions of the designs shown in Stalker and Parker's 1688 book, *A Treatise of Japaning and Varnishing*, some of the landscapes and floral arrangements are very similar in appearance.

Examination and X rays were done in the Royal Ontario Museum's Conservation Department, and chemical analysis was carried out at the Canadian Conservation Institute (Miller and Moffat 1994), to reveal the history of the piece since its fabrication. Analysis revealed that the exterior of the cabinet was completely refinished in the nineteenth century. Cross sections showed that a heavy black-pigmented layer was applied over the original design; the cabinet was then redecorated using shellac and, in many areas, an oil medium. Instead of the fine technique of suspending gold powders in the layers of decoration, the gold leaf was simply stuck on in large patches with an oil mordant. Flakes of gesso and gold in the crevices of the stand suggest that the surface was regilded with gold leaf at this time. Evidence indicates that there was also a later restoration, probably just prior to the cabinet's arrival at the museum in 1960. The later gilding had been removed to reveal the original silver leaf surface. In

Figure 3  
Interior of the cabinet in 1990. The original surface is in remarkably good condition.



addition, a poly(vinyl acetate) (PVA) varnish had been applied to the badly deteriorated front.

X-ray photographs were taken to determine if any of the original surface remained. Three images appear on the X-ray photographs: the image on the front of the doors, that on the back of the doors, and a third image hidden by the refinishing. Tracings on Mylar sheets were done of the front and back images. By superimposing the tracings, the differences between the original image and the nineteenth-century refinishing could be seen. In several areas, buildings were added where there had previously been delicate floral arrangements. Rocks and hills had been removed from the design, and figures were added in the foreground. In addition, the raised areas that had been decorated with plants were simply painted black, eliminating them from the overall scheme.

When the piece arrived in the lab, an evaluation of its condition was carried out. Shrinkage in the main body of the door panels had caused a large split through the center of each door, running from top to bottom. These splits had run through the entire thickness of the doors. In addition, numerous small splits were evident at the lower edges, where the horizontal cross pieces met the vertical panels. Losses in the surface layers on both sides of the doors were extensive along the edges of these cracks.

The interior and the exterior of the cabinet each had a distinct set of problems, due to their different histories. The interior sides of the doors and the drawer fronts presented surfaces that had been tampered with the least and were also in the best condition. On the interior of the doors, the surface was flaking badly in several areas. This appears to have been caused, again, by the overall dimensional change in the wood. Evidently, the flaking had been dealt with before by the application of a spirit varnish. On the surface of some drawers, losses had been infilled with this later varnish. The speckling on the moldings between drawers had been overpainted in heavy black varnish, probably shellac with lamp-black. This later overpaint was delaminating in some areas, revealing the original speckled finish.

The exterior had undergone many changes, each of these leaving its mark on the surface. The overall appearance at the time the cabinet entered the lab was very "plastic," with numerous gray blisters caused by delamination of the PVA varnish. There were also numerous small losses where the nineteenth-century finish appeared to be separating from the seventeenth-century finish. This separation had been going on for some time, as the PVA layer had infilled many of the earlier losses. Some areas of decoration have been lost. The original raised gesso areas on the front are dry and crumbling with numerous losses, as well. In addition, the nineteenth-century oil gilding on the front and sides has been shrinking over time, leaving the gold decoration with an alligatored, patchy appearance. In fact, the oil gilding and bronze powder designs on the sides have deteriorated to the point at which much of the design can no longer be seen.

Before any consolidation was attempted, the surface was cleaned of loose dirt with a brush or soft cotton cloth. The PVA layer was removed, as it was delaminating and had failed to consolidate the flaking surface. Solvent tests confirmed that toluene would remove the PVA varnish without disturbing the underlying, earlier work. The doors were detached so this could be carried out horizontally by rolling toluene swabs over the surface within a portable fume hood.

Experiments were also carried out to determine the best method for consolidating the friable shellac finishes on the interior without disturbing the cabinet's appearance; additional consolidants would only serve to disturb the lustrous finish on the interior. Tests were conducted using a tacking iron with a 1 mm tip to soften the small flakes and then press the molten shellac back into place without the use of an adhesive. This method was used to adhere tenting and lifting on both the interior and exterior of the cabinet. The result is a sound surface that retains its original character. The raised gesso areas on the exterior were consolidated by brushing on a 5% rabbit-skin-glue solution, while the losses were infilled with 6% poly(vinyl alcohol) and whiting mixed with lampblack and raw umber dry pigments. The surface of raised area fills were sealed with 30% dammar varnish in toluene and mineral spirits (1:1), then inpainted with ivory black in the same medium.

Two small "windows" were made by lifting off the nineteenth-century finish with a scalpel; this revealed exquisite but incomplete decoration. Due to the brittle nature of the original finish, as well as X-ray evidence indicating an incomplete surface, it was decided that there would be no attempt to restore the previous seventeenth-century finish. The only other work that was carried out was to give the front of the exterior doors a coat of dammar varnish in an attempt to unify the patchy appearance of the finish. The dammar matches the surface of the piece much more closely than the former PVA varnish.

## A Pair of French *Encoignures*



Figure 4  
One of the pair of eighteenth-century French *encoignures* before conservation. Note the difference between the condition of the door and the surrounding cabinet.

The second case is a pair of French *encoignures* dated to 1750 (Fig. 4). During this period it was popular in France to incorporate the use of Asian lacquer panels into the fabric of typical European cabinets. These pieces are a combination of Asian (probably Chinese) and European lacquer. The Asian lacquer panels have been split in half, the wood shaved down to a 2 mm veneer, bent into a curved shape, and applied to the doors. The curved doors are standard panel construction with a rigid frame and a fixed panel, both constructed of oak. The bent shape was achieved by a steaming-and-hardening process, as opposed to cutting the wood in a curve. In each case, the interior of the door was veneered in mahogany; the rest of the cabinet was fabricated around the door. The front of each cabinet was japanned in the style of the Chinese panel attached to it. It is interesting that the Chinese panel was completely repainted at the time of construction in order to better match the French japanning. The overpaint follows most of the design with surprising accuracy; for example, each needle of the pine trees has been precisely covered. However, in some areas there are design changes; certain trees have become rocks, and, in one case, a gold horse has been transformed into a dapple gray mare (Fig. 5).

Samples from the doors and japanned panels of both cabinets were sent to the Canadian Conservation Institute (CCI) (Miller, Helwig, and Sirois 1994) for analysis to confirm that the overpaint on the doors was contemporary with the fabrication of the cabinets. Photomicrographs and pigment analysis confirmed that this is the case. Analysis also revealed that the major component in the japanning was the diterpene resin sandarac with a fairly large amount of larch resin added. The usual larch found in old recipes is Venice turpentine, the diterpene oleoresin from the

Figure 5

Detail of the door shown in Figure 4, illustrating the extensive cracking, as well as the abraded area around the edges. Note the French overpaint on the Asian panel, especially the repainting of the horse and the trees transformed into rocks.



European larch *Larix decidua*; however, as the larch diterpenes present in these samples are not found in the European larch, it may instead be the Siberian larch, *Larix siberica*. The triterpene resin elemi is also present, as well as monoterpenes characteristic of oil of spike. Oil of spike, produced from the lavender plant *Lavandula latifolia*, was used as a slow-drying solvent for lacquers and varnishes. Elemental analysis on the metallic powders used to produce the decoration indicated they were made from a variety of alloys. In one sample, there was a high amount of tin, which differs from the expected copper-zinc alloys usually used in this type of decoration.

The poor condition of these cabinets, primarily due to the original construction methods, was exacerbated by poor storage over the years. It is not surprising that the main carcass (framework) of the cabinets, and the japanning on them, have fared better than the panel doors. In the original fabrication of the oak frame doors, the wood was put under a great deal of stress to achieve a curved surface. This stress has been relieved in different ways on each door. On the door of the cabinet featuring a hunting scene (Figs. 4, 5), the stress has been relieved by a large split up the center of the door, and the vertical panel has warped inward along the split. In the case of the second door, featuring a landscape (Fig. 6), the curved horizontal pieces of the panel frame have straightened out. A difference of 10 mm between the vertical part of the panel and the horizontal member has caused the Chinese panel veneer to shred at the juncture point, as shown in Figure 6. The surrounding lacquer understandably has lifted, and much has

Figure 6

Detail of second cabinet of the pair of eighteenth-century *encoignures* before treatment. Warped door with landscape design shows large split in veneer panel and extensive overfilling to compensate for the damage.



been lost in all four corners of the panel. The damage to the wood veneer on the interior of the door is much the same, with splits and areas of lifting corresponding to the distortions of the oak base.

Both doors exhibit a series of tented cracks, at 5–10 mm intervals, running over the entire surface. This stress-cracking phenomenon has been well documented by Kenzo Toishi and Hiromitsu Washizuka (1987:170–72) on pieces in Japan. In the case of these two cabinets, the stress was undoubtedly induced, in each instance, by gluing a flat Chinese panel to a curved surface. The cracks in each of the doors cross the grain of the wood of the underlying panel. Figure 4 shows this cracking in the first cabinet running horizontally over the vertical wooden panel and vertically over the horizontal members of the oak panel. This problem has been observed on other examples of French furniture in which Asian panels were glued to a locally made carcass. The National Gallery of Art in Washington, D.C., has a number of pieces by Jean Desforges, all exhibiting the same stress cracking (National Gallery of Art 1993).

The carcasses of the French cabinets were in much better condition than their doors, primarily due to the original construction methods. The curved shape on each front section was achieved by cutting the wood into that form. There are cracks between the joins of the four pieces that make up the front, but this is to be expected. The numerous small losses of the original japanning run with the grain of the wood, indicating that they have been loosened over the years by repeated shrinking and swelling of the wood, not by stresses set up in the initial construction.

It is natural that cabinets exhibiting this inherent vice would have undergone repairs at some point prior to arriving at the Royal Ontario Museum. There was evidence of at least two previous restorations to the pair. At one point in time the edges of the Chinese panel were readhered to the oak panel on both cabinets. At this time, the surface of the panel was severely abraded in an attempt to flatten the lifting lacquer. There is a 3 cm strip around the edge of each panel, in which all the European overpaint has been stripped off and the Asian lacquer stripped back to the base layer. The abraded area was then overpainted in black varnish, with bronze paint to imitate the decoration. The particle size of the later bronze paint was much larger, and the execution did not match the refined technique of the one first used. During this first restoration, losses to the panel were infilled with gesso and inpainted to match the surface.

A later restoration was carried out during the 1940s at the Royal Ontario Museum, in which an attempt was made on each cabinet to reconcile the different levels of the warped panel. A water-soluble putty was applied to the corners of the cabinet to level out the distortions; unfortunately, much of the design was covered in this process. These crude fills and the surrounding area have extensive black overpaint with bronze paint decoration. The same restoration method was carried out on cracks between wood members on the carcass itself.

The conservation treatment of these cabinets was time consuming, but not particularly difficult. The doors were detached from the cabinets to better facilitate the work of removing the 1940s fills and overpaint. Once the surface of the lacquer was clear, the structural work could begin. The interior wood veneer was easily removed with a spatula, as the animal glue was very dry and brittle. The horizontal oak pieces could not be detached from the lacquer panel on the front, so reshaping had to be done in place. Several shallow cuts were made across the grain at the point of



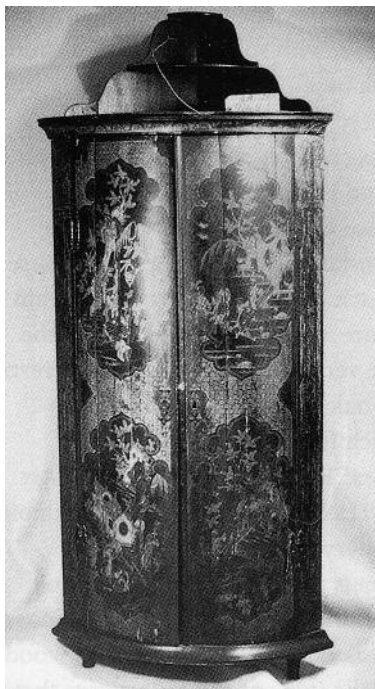

Figure 7  
Eighteenth-century English corner cupboard.

---

## An English Corner Cupboard

maximum warp, until the oak board could be pulled back into its original curve. Cold fish glue was applied to the cuts. Then the piece was clamped into the new shape until dry.

Once the distortions were corrected, one could see the extensive damage that had been caused by the warp. The wooden portion of the lacquer veneer had itself been distorted, and in some areas the wood had been shredded. The lacquer surface, unable to accommodate these changes, had lifted and flaked off in great quantities, while the remaining flakes had cupped. In most cases, the lacquer was sufficiently pliable that it could be laid flat using clamps. Where it was too brittle to flatten without breaking, it was softened prior to gluing by using a thermal sheet controlled with a rheostat to about 50 °C. Cold fish glue, with 10% ethanol added as a wetting agent to facilitate the flow under the surface, was injected to hold down both the distorted lacquer and its wooden base. The consolidation took several months, as no more than a few square centimeters could be done in a single day. The lacquer has a powerful “memory” of its distorted state, so a great number of clamps were required. In addition, large quantities of fish glue could not be used at one time because an excess of moisture would cause marks on the oriental lacquer surface.

Following consolidation, the veneer was replaced, and losses were infilled using 8% poly(vinyl alcohol) and whiting. The surface of the fills were inpainted with Acrysol WS-24 (an acrylic emulsion) and aniline dye to imitate the oriental lacquer. The japanned areas were inpainted with Liquitex acrylic medium and mica-based pigments, instead of the metallic powders used originally. These mica pigments match very closely the effect of the metal powder but have the added advantage of not tarnishing over time.

The fourth cabinet is mentioned only briefly here as a work in progress. It is an English corner cupboard, dated about 1750 (Fig. 7). Although it arrived at the museum with feet, it was originally a wall cabinet; the location of the drawer near the base, and holes to secure it on the wall, is clear evidence of its first purpose. It now looks like it was decorated in a black-and-gold chinoiserie style; however, again this was not its original appearance. The front has been revarnished many times; and over the centuries each of these layers has discolored, giving the background the dark brown color it now possesses. Close inspection of the interior drawer, which escaped revarnishing, indicates that the original color was much different. Although the old varnish has itself somewhat discolored, the initial blue color can be seen in the areas that have been protected by the gilding.

Analysis of the pigments and resins (Miller and Helwig 1994) with Fourier-transform infrared (FT-IR) spectroscopy, scanning electron microscopy (SEM), and microscopy at the Canadian Conservation Institute show that the ground layer was carried out using lead white and smalt (Fig. 8). The varnish layers directly on this ground layer were made using sandarac as the main resin, with additions of colophony and a small amount of larch resin. Traces of pinenes and verbenone would indicate that turpentine was used as a solvent. Smalt was added to this varnish recipe to make a type of colored varnish for the second layer, while subsequent layers contained the same varnish alone. A thin orange-red pig-

*Figure 8*

Photomicrograph of the various surface layers on the cabinet shown in Figure 7. From bottom to top, they are as follows: ground layer of smalt and lead white in an unknown medium, sandarac-based varnish with smalt pigment, clear sandarac-based varnish, thin red-pigmented layer under gilding, later shellac layer applied on top.

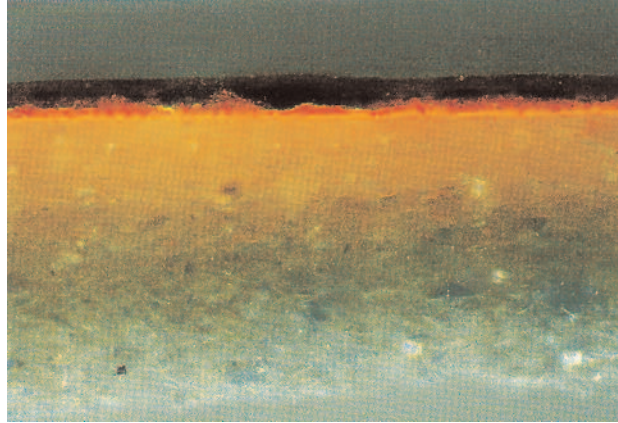

mented layer was found immediately under the gilding. This approach, and the resin used, correspond nicely to recipes found in the publications of both Stalker and Parker (1971) and Dossie (1764) for colored japanning. The later layers that had been applied at various times over the original finish were determined to be shellac, natural resins, and (in one area) linseed oil.

Unfortunately, time did not permit a complete treatment of this piece. The small losses of varnish that exposed the smalt and lead white base layer were toned in with Soluvar and pigment as a temporary solution until a complete treatment could be carried out.

---

## Conclusion

Although it is not necessary to carry out detailed chemical analysis of every piece of japanning before beginning conservation treatment, in the cases discussed here it has been most beneficial. The additional information has helped decide the overall treatment approach, and has also given a greater understanding of the actual methods used in the history of these pieces.

It is readily apparent that a glossy black finish is not necessarily shellac. A great many natural resins were used to achieve the hard glossy surface of lacquer. A look at the literature of the time tells us to expect to find many complicated formulas. Indeed, they are often more complicated than the paintings of that time, for which we have a large body of knowledge.

These four cabinets demonstrate in concrete terms exactly how perplexing it can be to visually differentiate between the various formulas. If there are facilities available for the detailed study of pieces in one's care, that study should be encouraged in order to build up a catalogue of information concerning these finishes. It is time that these pieces of furniture be given the same consideration as is given to fine art. Certainly, the makers had the highest regard for their works; to quote Stalker and Parker (1971:10), "You must not expect to raise a noble piece from dross or rubbish; to erect a Louvre or Escorial with dirt or clay, nor from a common Log to frame a Mercury."

---

## Materials and Suppliers

Acrysol WS-24, Rohm and Haas Co., Independence Mall Street, Philadelphia, PA 19105.

Poly(vinyl alcohol), BDH, 350 Evans Avenue, Toronto, Ontario, M8Z 1K5, Canada.

---

## References

- Dossie, R.  
1764 *The Handmaid to the Arts*. 2d ed. London: J. Nourse Bookseller.
- Miller, David, and Kate Helwig  
1994 Analysis of the finish on an English corner cupboard from the Royal Ontario Museum. CCI Analytical Report, ARS No. 3313.2. Ottawa, Canada: Canadian Conservation Institute.
- Miller, David, Kate Helwig, and Jane Sirois  
1994 Analysis of japanning on a pair of French encoignures from the Royal Ontario Museum. CCI Analytical Report, ARS No. 3313.1. Ottawa, Canada: Canadian Conservation Institute.
- Miller, David, and Elizabeth Moffat  
1994 Analysis of varnish and gilding mordants from a late 17th century japanned cabinet. CCI Analytical Report, ARS Nos. 3009, 3009.1. Ottawa, Canada: Canadian Conservation Institute.
- National Gallery of Art  
1993 *Eighteenth Century Decorative Arts*. Gallery guide. Washington D.C.: National Gallery of Art.
- Stalker, John, and George Parker  
1971 *A Treatise of Japaning and Varnishing*. 1688. Reprint, London: Alec Tiranti.
- Toishi, Kenzo, and Hiromitsu Washizuka  
1987 *Characteristics of Japanese Art That Condition Its Care*. Tokyo: Japanese Association of Museums.

# The Hunnewell Cottage

## Preservation and Re-creation of a Nineteenth-Century Exterior Paint Scheme

Andrea M. Gilmore

**J**OHAN W. MASURY, in his book titled *How Shall We Paint Our Houses? A Popular Treatise on the Art of House-Painting: Plain and Decorative* (1868:18–19), describes the transformation in the painting of American buildings in the second half of the nineteenth century as follows:

The business of house-painting has so outgrown its former insignificant proportions that its past and present features have almost lost their resemblance. Today, more money is expended on painting a single edifice than would have sufficed to paint every house in a respectable-sized town thirty years ago, and the amount of capital, skill and intelligence now required to conduct the business successfully in cities and large towns, was not dreamed of at the time.

The Hunnewell cottage in Wellesley, Massachusetts, designed by John Sturgis and built in 1871, exemplifies the zenith reached in exterior architectural painting in the second half of the nineteenth century (Fig. 1). The original paint scheme consisted of eight bold paint colors, selected to

*Figure 1*  
Hunnewell cottage, west elevation, Wellesley, Massachusetts, photographed before 1879. Original paint scheme.

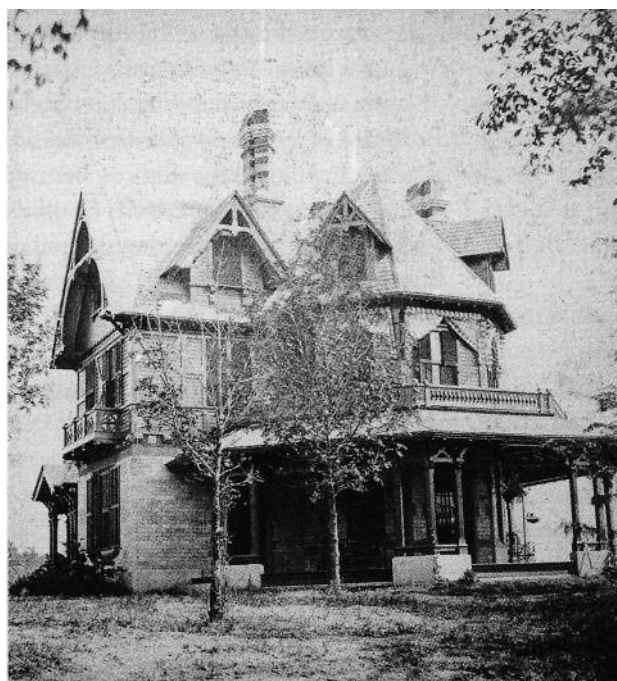

highlight the wooden architectural elements of the cottage: visible “stick style” framing, bargeboards, gable overhangs, gable brackets, incised detail in the vertical board sheathing of the dormers, and the beveled edges of the porch columns and bargeboards. They also complemented the masonry of the first story and the glazed tiles set into the brick at the junction of the first and second stories. In his choice of paint for the Hunnewell cottage, Sturgis illustrated the integral role that paint color played in his design. His work clearly reflects the statement made in the Devoe paint book, *Exterior Decoration*, of 1885 (1976:19):

Today, the architect, where he values his reputation and is desirous of giving his clients perfect satisfaction, is as solicitous of the color effect as of the general design of his work.

Exuberant late-nineteenth-century exterior paint schemes, such as that found on the Hunnewell cottage, often had relatively short lives. They were costly to maintain and repaint, and because these schemes arrived toward the end of the Victorian era, they fell out of favor within twenty to thirty years of their creation. In the case of the Hunnewell cottage, the original eight-color scheme was never repainted. When the library was added to the south elevation in 1879, the cottage was painted with the ever popular late Victorian scheme of red siding and dark green trim.

During most of the twentieth century, the important role of color in the design of Victorian architecture has been ignored. Grand Queen Anne and stick style houses have often been painted a single color, minimizing the effect of their ornamental architectural elements. In recent years, however, as interest in Victorian architecture has been rekindled, buildings are again being painted with the rich colors used in the second half of the nineteenth century.

Efforts to re-create appropriate and accurate exterior paint schemes for Victorian buildings have met with varying levels of success. The least accurate of these methods have used colors that are not appropriate to the Victorian period. The California “painted ladies” of the 1970s are representative of this type of pseudo-Victorian paint treatment (Moss and Winker 1987). Victorian schemes have been re-created more appropriately with colors specified in nineteenth-century house-painting guides. These recommend specific colors for different architectural elements and contain color chips that can be used to create alternative schemes. The most accurate restorations involve analysis of paint samples removed from a building to identify the original colors and the architectural elements on which they were used. This level of analysis was undertaken to identify the original paint colors on the Hunnewell cottage.

As re-created, the eight-color scheme documents the original, complex, late-nineteenth-century paint scheme. It reveals the important role that color played in the design of this cottage, particularly in the scheme’s relationship to the masonry materials, whose colors it replicates, and to the architectural elements it highlights. Further, it illuminates the role color played in Victorian architecture in general, dispelling the mystery and myth that surround the selection of paint colors for Victorian buildings.

---

## Historical Background

The appearance of elaborately colored Victorian houses in the second half of the nineteenth century coincides with dramatic changes that were

occurring in the American building industry. The rapid growth of the industries that produced building materials and the expansion of the railroads across the country transformed American house design and construction. The boxlike shapes of the timber-frame houses of the eighteenth and early nineteenth centuries were replaced with balloon-framed houses constructed with 5 cm (2 in.) dimensional lumber and wire nails. These houses had irregular floor plans, asymmetrical facades, and roofs formed by monumental gables that were punctuated with dormers, turrets, and towers. They were trimmed with mass-produced doors, windows, sheathing (shingles, clapboards, and vertical boards), and machine-turned or machine-cut ornamental trim. To accentuate the three-dimensional qualities of the design and the variety of materials used to sheathe and ornament the exterior surfaces, painters used the newly available, boldly colored, ready-mix paints on these houses.

Devoe, writing in 1885 about Queen Anne style houses, says the following about the use of paint colors to pick out exterior architectural features (Moss and Winkler 1987:26):

It [the Queen Anne style] furnishes an opportunity for the greatest display of taste in coloring and exterior decoration. The many fronts, diversified as to materials, with visible framing shingle or smooth covering, the gables, the porches, etc., all provide a means for the employment of parti-colored effects, the most attractive and artistically valuable features of modern house painting, and one that the old box-pattern house, with its plain flat front, does not readily admit of.

The proliferation of nineteenth-century house designs and paint schemes was facilitated by the publication of architectural pattern books and house-painting guides. The pattern books provided house plans, detail drawings of architectural trim, and materials specifications for Victorian houses of varying size and style. The house-painting guides included chromolithographs of houses painted with combinations of colors. These combinations were chosen to illustrate how different paint colors could be used with varying architectural styles and how architectural details could be highlighted with different paint colors. The colors in the chromolithographs typically were keyed to paint-color chips that were also included in the house-painting guides. In Devoe's house-painting guide (1885), most of the houses shown have paint colors for four elements: body, trim, blinds, and sash. The notable exception is plate 2, which is painted with a combination of seven colors: first story body, second story body, trim, blinds, sash, peaks and side dormer, and roofs.

Conservators of nineteenth-century architecture are seeking, through paint research, to understand how the information in the pattern books and painting guides was put into practice. This work involves the detailed examination of houses that were built and the identification of their original paint colors. The Hunnewell cottage afforded an opportunity for a paint study of this type, which revealed a paint scheme that documents the use of Victorian design and colors found in pattern books and painting guides. However, the Hunnewell cottage paint scheme exceeds those specified in the house-painting guides in terms of the number of colors used and the complexity of their application. The cottage's complexity reveals the need for paint analysis to accurately document nineteenth-century exterior paint schemes. Furthermore, the integral relationship of

the original paint scheme to the cottage design and building materials makes a compelling argument for its careful conservation.

---

## Paint Investigation

The identification of the original paint colors began with the examination of a photograph taken of the cottage around 1875 (Fig. 1). The photograph showed a polychromatic paint scheme in the varying tonality of the black-and-white image. It also showed the polychromatic effect of the different masonry materials used to construct the first story—cast stone, brownstone, brick, and granite, and banding in the slate roof and stripes painted on the chimney.

On-site work began during the summer of 1992 with a quick examination of the existing paint scheme. All of the wooden elements had been painted tan, and the shutters had been removed (Fig. 2). Craters made in the paint, examined with field microscopes, revealed an interesting but confusing layering sequence. Some of this confusion was eliminated by comparing the layers on the original house with that of the 1879 addition. The addition originally had a two-color paint scheme—a dark red and dark green design—which became a guide, both in the field and in the laboratory, for identifying the finish layers of the original scheme.

In the field, some of the general colors of the original paint could be identified—the tan on the clapboards, the red-brown on the trim, the blue on the underside of the gables, and the bright red-orange that was used to accentuate some of the architectural trim. More important, however, the field observations revealed the need for extensive sampling to identify the original locations of the many paint colors and the need to develop a system for keying the paint samples to photographs or drawings, so that the original design could be accurately reproduced. Ideally, when such an elaborate paint scheme is documented, measured drawings will exist for the building. Unfortunately, none of the Sturgis drawings for the Hunnewell cottage survive, so photographs had to be used to record the locations of the element samples.

In the laboratory, microscopic examination of paint-sample cross sections revealed that the original design had been created with eight different colors. It also revealed that the paints on the trim had been built up in layers, with the dominant red-brown trim color applied first, followed by the different colors used to accentuate the architectural ornament.

*Figure 2*  
Hunnewell cottage, 1992, before the original paint scheme was restored. The cottage is shown with a monochromatic tan paint scheme, and the exterior blinds have been removed.



Samples of each of the finish paints identified in cross section were exposed with a scalpel and matched to Munsell color standards. Color matching did not involve any adjustment for color change over time, beyond a sampling strategy that located well-protected samples in thick layers that were judged to be the truest colors surviving on the cottage. The colors used to re-create the original paint scheme are given in Table 1.

Because it would have been prohibitively time-consuming and costly to sample and prepare a cross section for every architectural element, after the original colors were identified in the laboratory, field microscopes were used to confirm their location on many of the exterior surfaces. This proved to be a particularly important strategy for verifying the locations of different colors, as some of the high gables were available for examination only after the painting contract began and the gables became accessible from the ladders and scaffolding.

Field microscopes were also used throughout the contract to verify paint locations and to establish boundaries between the different colors. Identifying the boundaries was one of the more challenging tasks involved in re-creating the original scheme, since so many colors were used on such complexly shaped architectural elements. Boundaries were established by cutting a channel in the paint, approximately 3 mm wide, across the suspected boundaries of the different architectural elements and viewing the sides of the channels using a field microscope to identify where the color changes occurred.

The findings of the paint study were recorded in a report that documented the procedures used to identify the original colors. The report made recommendations for re-creating the original paint scheme of the cottage and was used to prepare the specifications for the job.

---

## Re-creating the Original Paint Scheme

The re-creation of the original paint scheme posed several conservation and technical challenges. The conservation issues involved the question of how to preserve original paint evidence and how to prepare the surfaces for repainting. The technical challenges involved transmitting the paint color information to a paint contractor for accurate replication.

The existing exterior paint surfaces exhibited the typical aging characteristics of one hundred years of paint buildup (cross sections revealed that the cottage had been painted eight times) and weathering. Many of the painted surfaces were alligatored, and others were peeling;

*Table 1* The eight colors used to re-create the original paint scheme on the Hunnewell cottage

Architectural element	Munsell color notation	Color
Clapboards	10 YR 5/2	brown
Wood trim (principal color)	2.5 YR 3/4	dark red
Blinds and window sash	5 Y 3/1	dark olive green
Underside of overhanging gables	7.5 BG 7.4	sky blue
Vertical board sheathing	25 Y 6/6	mustard yellow
Incised detail in vertical board sheathing	7.5 Y 4/2	olive green
Gable brackets	5 YR 2/4	dark red
Ornamental wood trim highlighting	10 R 5/10	orange



paint loss had fully exposed the wood of some elements. Most of the paint was lead based, adding a further consideration to all surface preparations.

Traditional restoration of an original paint scheme would have involved stripping all of the alligatored and deteriorated exterior paint. (It was estimated that about 90% of the painted surfaces would have had to have been stripped.) Stripping would have created a clean, smooth substrate for repainting. It would also have removed layers of paint that had filled in around the carved ornamentation and restored the depth and detail of the carving.

In recognition of the significance of the exterior paint scheme preserved on the Hunnewell cottage, however, it was decided that a much more conservative approach to surface preparation would be undertaken. Instead of stripping all of the aged paint surfaces, all of the well-bonded paint—even if alligatored—was preserved. Peeling paint was scraped by hand, and areas of paint loss were feathered into the adjoining paint edge and lightly sanded. The surfaces were then primed, and a finish coat of paint applied. The decision was made to apply only a single coat of finish paint, rather than the two coats traditionally used for a high-quality paint job, in a effort to minimize paint buildup. Since many of the trim elements were, by the nature of the paint scheme, to have multiple paint layers, limiting the base layers to two coats seemed an important long-term preservation decision. However, adequate coverage was not possible with one finish coat on the dark green of the sash and shutters; therefore, two coats were applied in these areas.

The level of surface preparation chosen balanced the goals of (1) preserving as much of the early paint as possible and (2) preparing the surfaces so the new paint would be adequately bonded to ensure a durable paint surface.

The next task was to prepare a specification so the work could be competitively bid, using a standard specification for exterior painting on a historic building. The bid was sent to three prequalified painting contractors. Each contractor was interviewed at the cottage to ensure that he understood the condition of the existing paint, the level of surface preparation specified, and the complexity of the paint scheme to be re-created. Contractors also were told that the contract would be supervised by the architectural conservator who had conducted the paint research and that the conservator would have access to the scaffolding so that paint color locations could be verified throughout the duration of the contract.

The contractor selected had extensive experience painting larger, multicolored Victorian houses. He also had an immediate understanding of the conservation goals as they related to the original paint scheme and surface preparation. Furthermore, he was sensitive to the need for field decisions based on the exposure of additional paint evidence during the course of the contract.

Because the groundwork for the contract had been carefully laid, the actual painting project went very smoothly. The degree of surface preparation was reviewed on each elevation of the building and tailored to the amount of paint deterioration encountered. Since Munsell color standards are not commercially available paint colors, finish paints were custom mixed and approved prior to application. Several colors required adjustment: the heavily pigmented colors found on the cottage were relatively challenging to re-create using the modern bases of commercial paints, and it took several attempts to achieve an accurate color match.



*Figure 3*  
Hunnewell cottage, 1995. Original paint scheme re-created.

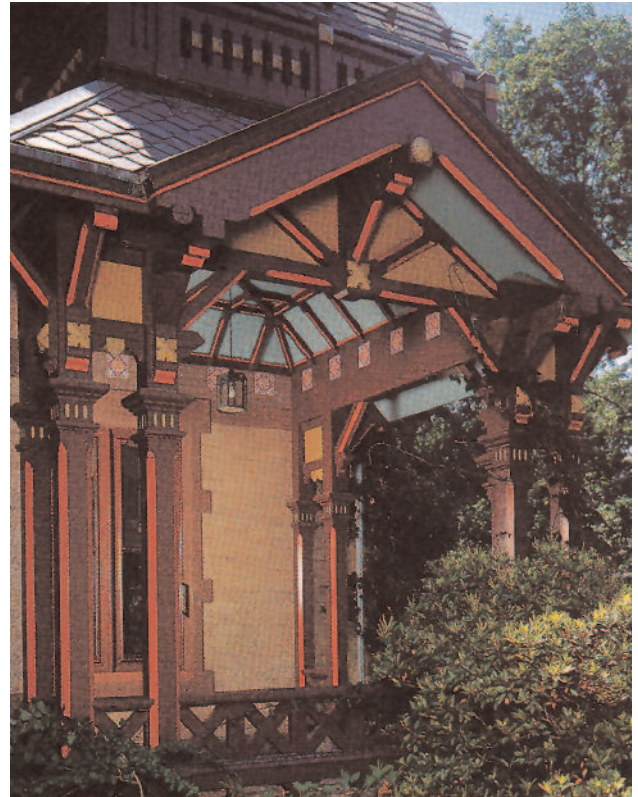

*Figure 4*  
Hunnewell cottage, 1995. Detail of the entry porch column.

Biweekly meetings facilitated regular review of the placement of colors, making detailed drawings specifying color locations unnecessary.

The sequence of work was as follows:

1. Pressure washing of the surfaces to remove dirt and pigeon excrement. (Pressure washing is not generally recommended as part of paint preparation for a historic building; however, because of the pigeon excrement and general surface soiling, it was deemed necessary for this project.)
2. Scraping and sanding of the deteriorated paint. Sanded surfaces were wiped with a rag dipped in mineral spirits to remove dust prior to painting.
3. Priming with a gray oil-based primer.
4. Application of a finish coat of oil-based paint. As in the original painting, the principal exterior paint colors were applied, followed by the colors used to accentuate the architectural ornament.

Figures 3 and 4 show the completed paint scheme.

---

## Summary

The paint study and the re-creation of the original paint scheme on the Hunnewell cottage revealed the important role played by paint analysis and the conservation of exterior architectural paints in the preservation of Victorian architecture. The full range and placement of colors on the cottage could not have been determined without the thorough sampling and analysis of the original paints, nor could the architect's full design intent have been understood without knowledge of the exterior paint colors.

The tan, monochromatic, prerestoration paint scheme obscured the incised detail in the vertical boards in the dormers; the beveled edges of the stick framing, porch columns, and bargeboards; and the ornamental brackets of the overhanging gables. Painted in eight colors, this architectural detail has now become an intricate three-dimensional design whose complexity is akin to the delicate pattern and colors found on the glazed tiles that Sturgis set in the brick band at the top of the first story.

---

## Acknowledgments

The author would like to acknowledge Jane Hunnewell, who undertook the paint study and restoration of the Hunnewell cottage. Her intellectual curiosity and love for her family home provided the conservation team with the opportunity to retrieve this remarkable nineteenth-century exterior color scheme.

---

## References

- Devoe, F. W.  
1976 *Exterior Decoration*. 1885. Reprint, Philadelphia: Athenaeum.
- Masury, John W.  
1868 *How Shall We Paint Our Houses? A Popular Treatise on the Art of House-Painting: Plain and Decorative*. New York: D. Appleton.
- Moss, Roger W., and Gail Caskey Winkler  
1987 *Victorian Exterior Decoration*. New York: Henry Holt.

# Technology and Conservation of Decorative Surface Systems of Horse-Drawn Vehicles

Marc A. Williams, Merri M. Ferrell, and Jennifer Baker

IN HIS BOOK *House-Painting, Carriage-Painting and Graining*, John W. Masury (1881:243)<sup>1</sup> concisely describes the desired qualities of the carriage finish: “To show the best possible colors, the light must be reflected, not from a flat, opaque surface, but from a surface which has beneath it a depth of continuous colored particles reaching way down through the successive coats of varnish to the groundwork.” This deep, jewel-like surface was achieved by selecting combinations of base colors and glazes that complemented each other. The use of colored varnishes and glaze layers to tone paint layers before varnishing was considered one of the more subtle aspects of carriage painting and one that separated experienced painters from amateurs. This was an area in which the painter’s aesthetic abilities could be highlighted. One British writer (Shinnie 1902:480) complained that “the French and Americans seem to excel us in this. They operate with great daring in the glazing of contrasts, but with brilliant effects.” Gardner describes glazing in the following way (1885:170):

The art of giving a ground-color a different shade or richness by coating it with a transparent glaze or thin wash. The pigment, such as carmine, ultramarine blue, etc. is mixed with varnish to form a sort of colored varnish, not a solid covering, and then applied the same as varnish to a ground quite near the color of the glaze.

While there were some minor variations from shop to shop, the industry had fairly standardized methods for applying carriage paint. In addition to aesthetics, durability was a primary consideration. The finish had to stand up to the jarring shock of cobblestone or brick city streets without becoming too brittle and breaking off. Finishes were also subjected to extremes of weather. The process was both labor and materials intensive, involving the application of up to two dozen layers of slow-drying paint and varnish, many of which were almost completely rubbed off again, in order to obtain a flawlessly smooth finish. Trade literature from the close of the century shows that over the years the overall number of layers decreased, in an effort to cut costs and speed up the process. In his book, *The Carriage Painter’s Companion*, Masury writes that it takes fifty days of labor to paint a coach (1871:182). In comparison, in *Automobile Painting and Carriage and Wagon Painting*, a paint sequence requiring only ten to twelve days is described (Vanderwalker 1917:150–53). A letter to the

editor in an 1880 issue of *Coach Painter* boasts of completing a successful paint job in only twenty-one days (Ferrell 1983:81). Also, most carriage painting manuals distinguish between “heavy work,” such as coaches or drags, and “light work,” such as buggies or sulkies, with the former requiring much more effort to achieve the desired finish. A direct correlation was made between the quantity of time it took to complete a paint job and its quality; this was something about which many painters felt strongly, as is evident in the following quote (Masury 1881:222–23):

The case of the captive children of Israel has its parallel in the carriage-trade, and that the carriage-painter is oftentimes required to perform a labor more difficult of accomplishment than was required of the Jewish bondsmen by their Egyptian taskmasters. To make sun-dried bricks without straw may, so far as we know, be within the limit of human ingenuity; but to begin and complete the painting and varnishing of a carriage—so as to secure the best results as to durability—in the space of two weeks, is a feat beyond the skill of any man who ever yet painted carriages on this mundane sphere.

---

## Materials and Terminology

By the last quarter of the nineteenth century, the commercial paint industry was well established, and carriage painters no longer needed to prepare their own paints or varnishes. However, many carriage painters continued to grind and mix their own formulas, and writers of manuals gave instructions on how to do this while also promoting their favorite brands (Gardner 1875:27). It was not unusual to buy proprietary compounds and mix them together to get various formulations for ground coats, or to alter paint colors by adding dry pigments or mixing paints together. Trade manuals contained long lists of how to mix and match different colors.

To understand the process involved in painting a carriage, it is necessary to become familiar with the materials and the terminology used. Many of the materials, such as linseed oil, are still available and require no explanation. Other terms, such as *keg-lead*, are specific compounds that no longer exist. Still other terms, such as *japan* or the all-encompassing *varnish*, cover an entire range of mixtures that seem to be kept deliberately vague by manufacturers trying to keep trade secrets, as well as promote their range of products. In *Modern Carriage and Wagon Painting* (1911:23), Frederick Maire writes, “Japans do not differ much from varnishes and under that name all kinds of liquid stuff is sold in the market which have nothing much in common but the name under which they are sold. The formulas for making them differ so much that it is really impossible to give a clear definition of them.”

Also, different sources sometimes contradict each other as to ingredients of similarly named materials. Descriptions often contain terms that themselves are unfamiliar and go undefined. The following definitions are found in *Everybody's Paint Book*, by Franklin B. Gardner (1905:171–73):

*White lead*: a pigment made by subjecting the metallic lead to the fumes, or corroding influences of vinegar, when it becomes a fine white powder. *Keg-lead, or tub-lead*: white lead ground in huge mills while mixed with linseed oil. *Rough Stuff*: a rough-grained paint designed to level over any hollows or imperfections. . . . It is composed of some cheap ochre or other hard and gritty pigment. . . . Take equal parts of dry-white lead and Grafton paint or

English filling (an earth) and mix them with equal parts of rubbing varnish and brown japan; grind loosely through the paint-mill; then thin to a working consistency with raw linseed oil one part, turpentine two parts. *Japan Drier* or *Brown Japan*: a drier for paints made by boiling linseed oil with substances which give it drying properties, such as manganese, sugar of lead [lead acetate], red-lead, litharge, etc. and adding for a body, gum shellac or inferior varnish gums. *Black Japan*: a solution of asphaltum in linseed oil or varnish.

Linseed oil and lead white were probably the two most universal ingredients in carriage paint. Generally, raw linseed oil was preferred over boiled, especially for foundation coats. In his paper on carriage painting, Robert Shinnie writes (1902:478), "The use of boiled linseed oil has entirely disappeared." Gardner emphasizes only using raw linseed when making keg-lead (1875:22). In an 1880 article in *The Coach Painter*, "Liquids Employed in Painting," the writer states (Ferrell 1983:103):

Linseed oil, which is the most common vehicle used for oil painting, is usually mixed with pigments in two forms—as raw linseed oil, and as a drying or boiled oil. . . . Experience has taught that it is better to give to the mixture a drying property with japan, than to boil the oil and thus increase its oxidizing power. And we find most painters have discarded almost entirely that black gummy material *Boiled oil*, from the paint bench.

By 1911, however, linseed oil is mentioned less favorably in the literature. Maire (1911:23) writes, "Linseed oil is sparingly used in carriage painting," and that "the old adage . . . 'oil is the life of paint' must be forgotten when it comes to carriage painting." He also states that the "principal and only use made of linseed oil is in the primary or foundation coats."

The term *japan* was one that was frequently used for a variety of meanings. As one of the above definitions indicates, *japan* usually referred to a metallic drying agent added to paint in order speed up the oxidation of the linseed oil. But *black japan* refers to a varnish layer that was frequently applied over gilded surfaces. There are several references to the use of asphaltum as a toning layer over gilding (Gardner 1885:35). Japan was also used as a size for gilding. In *Modern Pigments and Their Vehicles*, Frederick Maire writes (1908:214), "It is a very hard matter to give a true definition of what is really meant by the term *japan*, notwithstanding the daily use of it in the paint shop. . . . It is needless to say that japans vary as much in their composition as they do in their qualities." Maire goes on to give three different definitions for japan—one as a drier, as described earlier, and one as an enamel that is used for baked-on finishes. The third class, he writes, "which are for grinding and applying coach colors, are properly varnishes and of such are the gold sizes and coach japans, and in reality should be classed among the medium grades of varnish." An ad in *The Carriage Painter's Companion* (Masury 1871:14) lists "Coach Makers' Japan, For Binding and Hardening Paints," but adds, "It is made from the finest Shellac." This is one of the few references to the use of shellac in carriage painting.

The term *varnish* is the most general of all in the carriage trade. The success of the paint job depended on a high-quality varnish job to achieve a deep, glassy surface. Much attention was paid to the quality of varnishes and the skill of the artisan applying it. Once again, the composition and terminology are kept deliberately vague by manufacturers,

although the most commonly cited ingredients are linseed oil as a binder, copal as the resin, and turpentine as a solvent. Oil-resin varnish mixtures were by far the most popular type. One book states, "Quick drying hard varnishes, such as used on furniture is not suited to varnishing painted surfaces, especially if the work be exposed to the weather" (Masury 1881:181). *Everybody's Paint Book* defines carriage varnish as being "made by melting copal gum, mixing it with linseed oil and adding a drier to it, then thinning to the proper consistency with turpentine" (Gardner 1905:174).

Most manuals and magazine articles emphasized the importance of high-quality materials in both paints and varnishes. As one writer states, "Labor or wages bring the greater item of cost in carriage painting; it is not affected either way by the quality of materials used. The difference, if any, is in favour of the highest grade of goods being used. On the painting of one carriage the difference in cost is too small to be reckoned on" (Shinnie 1902:481).

Although few carriage painters mixed their own varnishes, they were encouraged to be knowledgeable about ingredients and manufacturing processes. The *Hub* magazine even ran a six-part series on copal, tracing it from its source through manufacturing. The articles suggest that the term was used for any fossilized resin found off the coast of East Africa that was insoluble in either water or alcohol. Conversely, gums were described as any water-soluble plant exudate (not fossilized); resins as any alcohol-soluble plant exudate; and gum-resins, such as myrrh and gamboge, as plant exudates that can only be obtained by bruising the tree. One article also suggests that, while copal is the most desired ingredient for high-grade varnishes, using other materials, such as dammar, kauri, animé, and sandarac, was acceptable for lower grade varnishes (Houghton 1871:132, 156).

Manufacturers also made a wide variety of varnishes for any conceivable application. Whether there were any differences inside the cans, or only in the labels, is unknown. An advertisement for Murphy and Company varnish makers lists six different varnishes and one japan for finishing. The varnishes have names such as "wearing body," "hard drying body," and "elastic carriage," each with a specialized function (Masury 1871:14).

Painters were aware of the yellowing effect of the varnish, even when new, and complained that it made blues and blacks appear greenish. To reduce this effect, varnishes were also used as vehicles for pigments in carriage painting. All the layers of varnish except the last one would be toned with pigments and were referred to as *coloring varnishes*, which were different from glazes in that they could be rubbed out between coats, and glazes could not.

One place where there was some variation in varnish ingredients was over white paint. Although paleness in color was considered an important quality of a high-grade varnish, carriage painters complained that white still turned yellow under the standard varnish. As a remedy, Gardner recommended substituting dammar for copal (1905:7). Sometimes whites were left unvarnished. Instead, the varnish was mixed into the final two coats of paint to make it glossier, and then polished with pumice stone when dry (Schriber 1891:69).

Carriage painters had the same wide range of natural, commercial, and synthetic pigments that were available to other painters at the end of the nineteenth century. Books were divided between those that advised using prepared colors (frequently published by paint companies)

and those that recommended grinding and preparing colors from dry pigments, linseed oil, turpentine, japan, and varnish. In *The Complete Carriage and Wagon Painter*, the author, Fritz Schriber (1891:17), lists twenty-five different pigments and instructions for grinding and mixing them to make a wide range of colors. Schriber states, "Prepared paints are perhaps to some a blessing, but he who would use economy in his own work must surely mix and grind his own colors." In *The Carriage Painter's Illustrated Manual* (1875), Gardner also lists a sample of thirty-six pigments (in *How to Paint*, 1885, he lists forty-six), with directions on how to grind them in the same manner as in Schriber's book. Gardner also recommends the use of prepared colors from Masury and Whiton, Globe Lead Works (1875:27), "as superior to anything else of the kind I ever tried."

Painters were advised to know about pigments and their origins, mainly in order to be on constant guard against adulterated and impure materials. Many of the long-established naturally derived pigments, such as earths and lakes, continued to be popular alongside the newer synthetically derived pigments (*Hub* 1889:352). Carmine was the most expensive pigment that was widely used by carriage painters, and because of its price, it was only used in glaze coats. Made from cochineal, it cost about US\$3.50 an ounce in the 1880s, whereas other pigments were sold by the U.S. pound, pint, or gallon, costing anywhere from \$2.00 to \$8.00 per pound. Consequently, other red lakes, such as Munich lake, were often substituted to save money. Carmine was frequently applied over vermilion for a deep brilliant red.

There was no uniform nomenclature for describing pigments, especially synthetic ones. An article in the *Hub* complains that recipes copied from English carriage publications contain color terminology unfamiliar to Americans in the trade, such as Berlin blue, Cassel earth, and Paris red. Also, tertiary colors and tints, such as "drabs, buffs, olives, browns," varied from one painter to the next (*Hub* 1888:422).

Trade magazines also had articles on how to do fancy work, such as scrollwork, monograms and crests, gold-leaf striping, faux caning, using transfer ornaments, and bronze powder stenciling. Good carriage painters were expected to be skilled in all of these techniques. Monograms and heraldry, in particular, were an area of carriage painting that became a subspecialty within the trade, and their design and layout was a favorite topic for paint-shop columns.

---

## Paint Stratigraphy

One of the primary goals of a good carriage paint job was to unify an assortment of parts, made of a variety of materials by different departments, into a harmonious, aesthetically pleasing unit. The body panels of a carriage required more extensive attention than the gear of a carriage. In larger companies, the two separate components might be painted in different departments. Although the gear—which was always part metal and part wood—required fewer coats of paint, they also required skill and effort to make the two different materials appear as one component and to build up layers on complex shapes.

There were two prevailing methods of carriage painting during the second half of the nineteenth century, the "old" method, which used keg-lead and linseed oil to fill the grain, and the "new" or "putty knife" method, which used a proprietary compound known as PWF (Permanent Wood Filler or Patent Wood Filler, depending on the source), containing



silicate or mineral pigments in linseed oil as a thick putty. Most carriage-painting books described one or both of these methods, and there was constant argument in trade publications as to which was superior. Although painting guides varied somewhat in number of layers, drying time, or proportions, general methods and materials were fairly consistent.

The “old” method of carriage painting started with several lead coats, five being a typical number. The first two were primers, the third a “putty” coat to fill any depressions. The coats were made up of varying proportions of linseed oil, lead white, japan drier, turpentine, and varnish. The putty coat also contained whiting. The first coat was primarily linseed oil, which was gradually reduced as more japan drier and lead white were added with each successive coat. The process was similar for the body and the gear up to this point, except that the gear was sanded, as the next series of coats was applied only to the body (Masury 1881:198–200).

The next several (five to seven) coats were known as the *rough coats* or *rough stuff*. These were made of *English filling* (an inexpensive earth pigment such as yellow ochre), lead white, varnish, japan, linseed oil, gold size, and turpentine. The amount of oil was reduced with each successive coat. The final layer was known as a *guide coat*. A layer of yellow ochre was mixed with japan and turpentine, applied, and allowed to dry. Then the entire coat was removed with pumice so any imperfections would show up. These were filled and sanded. The rough coats were applied only to carriage bodies, not to the gear (Masury 1881:200–202).

After all of this surface preparation, the final color layers (termed *color coats*, in that period) were actually quite thin. Typically, two layers of paint were applied. As they became available, commercially prepared paints, with their much more finely ground pigment particles, quickly replaced hand-mixed paints. Striping coats could be applied either over or under the final varnish, depending on their width and color (Burgess 1881:120).

Varnishing was considered the most critical part of the carriage finish. The body usually received five coats—four *rubbing coats* and a final varnish—and the gear received two. The rubbing coats were usually pigmented to reduce yellowing and were rubbed out between coats.

Most of the materials used in carriage painting required very long drying times. The lead priming coats usually required three to four days per coat, and the remaining coats were always allowed to dry overnight, if not longer. This was one reason why painters were constantly looking for ways to shorten the painting process.

The “new” method of carriage painting, also called the *American method*, differed from the above method in that the first five lead coats were replaced with one or two coats of PWF. This was a proprietary compound that was sold ready-made, starting around 1867. It saved time because fewer coats were needed, and the painter did not have to spend time running it through the paint mill. Silica, flint, or earth pigments were substituted for lead white as the wood grain filler, although it still may have contained some lead component. In an ad in the *Hub*, PWF was promoted for its “simplicity of application—uniformity of work. Non-injury to health, cleanliness, economy of time, labor and cost” (*Hub* 1878:313). Another ad in the *Hub* boasted that it was safer, and prevented “painter’s colic” (*Hub* 1893:87). Many articles in the “Paint Shop” column of the *Hub* make references to the hazards of lead, indicating that workers were aware of its toxicity. Painters

were advised to wash their hands before eating lunch, not to eat in the paint room, and not to wear paint-covered clothing home.

---

## Repainting

In studying the techniques of carriage painters, it is necessary to also become familiar with repainting techniques. Repainting and revarnishing of vehicles was very common, and many manufacturers did a brisk business in carriage maintenance and upkeep. Carriages could be repainted as often as once a year, although it was probably more common to just revarnish annually and repaint after two to five years, depending on use and color. Certain colors, particularly those made with lakes, were especially fugitive. A table in *The Art and Craft of Coachbuilding* (Philipson 1897:148) rates the durability of different paint colors after either two or five years. Scarlet lake is described as “dull pinkish red,” and crimson lake is described as “almost gone.” In contrast, madder red, true Naples yellow, and artificial ultramarine are listed as having no change of hue.

Both magazines and trade manuals made numerous references to repainting and revarnishing. A variety of different techniques were used, depending on the degree of damage to be repaired and the customer’s budget. A letter to the editor in the *Hub* asks about the best way to remove varnish without damaging the paint. The response gives three choices of chemicals: spirits of ammonia; strong potash water or lye; or a mixture of carbolic acid, creosote, and turpentine (*Hub* 1878:286). *The Complete Carriage and Wagon Painter* also gives instructions on revarnishing, but recommends removing the old varnish mechanically with pumice, instead of chemically (Schriber 1891:152).

There were many ways that carriages were refinished. The most drastic method was to take a hot iron and burn off the old paint down to the wood. Gardner (1875:67) recommends the use of a “furnace patent lamp” to remove old paint. The carriage was then repainted in the same manner as new carriages. Other methods were to sand off the varnish and color coats, leaving the rough and primer coats; or to just sand off the varnish, but leave the color coats, and apply new color coats and varnish. These methods were more economical for the customer. Frequently, the body of the carriage was stripped down to the wood by either burning or sanding, but the running gear was only sanded down to the rough coat and then repainted. As time went on, less and less effort was put into surface preparation and repainting. A less professional repainting job would be to apply just a coat of black to the entire vehicle.

A chart of sleigh repainting prices, from Brewster and Company of New York City (1897), shows the choices available for repainting. Eight different options are listed, priced according to the amount of labor required. The most inexpensive option (\$0.25) was “blacking off” the iron work, or repainting it black to hide the rust. Other choices listed were paint runners and touch-up all over—\$2.00; touch-up and varnish body—\$3.00; japan stripe and varnish body—\$5.00; recolor, japan, stripe, and varnish body—\$7.00; burn off and repaint body—\$7.00; paint runners, touch-up, and varnish gear—\$3.00; paint runners, recolor, stripe, and varnish gear—\$7.00; cut down, repaint, stripe, and varnish gear—\$9.00. The prices listed are for a cutter (a small sleigh), and show the amount of labor for each operation. For larger sleighs, the prices increased accordingly.

Another chart gives prices for repainting and restriping gears. The choices are to “cut down” or “scrape off” the old paint, with scraping being the more expensive option. Also, separate prices were given within each of these two options as to with or without a final rubbing varnish. Brewster and Company’s “Revised Price List for Painting C.P.’s. April 10, 1897” lists four options. The prices, given for comparison, are for “Drags or Perch Breaks”: new price without any striping—\$35.00; repair price when less rubbing coat, not striped—\$31.00; paint rims, touch-up, and varnish—\$16.00; recolor; striping additional: 1 coat—\$26.00, 2 coats—\$28.00. The price list for the body work is similar, with an additional column for “Addl. cost burning off old bodies.”

---

## The Concord Coach

While general painting materials and techniques were applied to a wide variety of vehicles, the examination and conservation treatment of a Concord coach (ca. 1866) provided an opportunity to examine specific methods. In 1813, Lewis Downing moved to Concord, New Hampshire, from Lexington, Massachusetts, and began making modest buggies (Concord and gig wagons)—vehicles with no springs and the bodies fastened to the rear axle. In 1826, he contracted with J. Stephen Abbot of Salem, Massachusetts, a journeyman coach-body builder, to build several coach bodies. These were the prototypes for what became known as Concord coaches. Their primary design feature was the use of leather thoroughbraces as a method of suspending the body from the running gear. This softened the ride considerably, allowing comfortable transit over quite rough roads. With the success of these vehicles, the partnership of Downing and Abbot was formed.

In 1847, the partnership dissolved. Downing formed Lewis Downing and Sons. Abbot worked alone until 1852, when he united with his son as J. S. and E. A. Abbot. The two firms merged in 1865 as Abbot, Downing and Company. In 1873, a corporation was formed, also absorbing the competing firm of Harvey, Morgan and Company. The new incorporated name was Abbot-Downing Company. By the second quarter of the twentieth century, pressures from both the railroad and the automobile had greatly reduced the demand for their products, and the Abbot-Downing Company closed its doors.

The Concord coach body generally was primed in a thin lead primer to allow penetration into the wood. This was followed after drying with a coat of lead primer, then with four or five coats of *rough stuff*. After sufficient drying, it was rubbed as smooth as glass with lump pumice and water, then thoroughly washed and dried. Two coats of ground color were applied to this surface. A coat of quick-drying varnish was applied next and was allowed to dry for several days. It was rubbed with ground pumice in water, and the body was ready for ornamentation.

Ornamenter were skilled painters, often filling their spare time with the painting of portraits or landscapes for private patrons. The most well known was John Burgum, a young Englishman, who joined J. S. and E. A. Abbot’s shop, eventually working for Abbot, Downing and Company after the merger. His career lasted until the early twentieth century, and he was responsible for factory decoration on many of the surviving Abbot-Downing coaches. As was the practice of the time, ornamenter usually painted only the decorative panels on the doors and on the driver’s seat riser. These were popular or unique images that could be determined by

the purchaser of the coach. The letterers were responsible for the scroll-work, much of which was quite ornate, as well as for striping and lettering. Following an appropriate drying time for the paint, one or two coats of protective varnish were applied.<sup>2</sup>

---

## Stony Brook's Concord Coach

The Museums at Stony Brook's collection of 250 carriages includes five vehicles made by Abbot, Downing and Company: a Standhope gig; a Hack passenger wagon; a twelve-passenger coach and companion mountain wagon; and a nine-passenger Concord coach, which underwent conservation treatment (Fig. 1). Because of their famed strength and durability, Concord coaches were a primary means of most public overland travel prior to the advent of an extended railroad system. Following the completion of the transcontinental railroad and the more prevalent use of the rail system as a means of long-distance travel, the ubiquitous Concord coach was utilized again for short-distance transportation by commercial lines to service hotels, towns, and areas not accessible by rail.

Perhaps more than any other vehicle type, the Concord coach holds a special place in the collective American experience. Although they were made in New Hampshire and used throughout the United States, South America, Australia, and other regions requiring rugged overland transport, they are most closely associated with the romance of the American West. However, Concord coaches in original, historical condition are increasingly rare. Because of their romantic appeal, they have been collected and restored to suit individual tastes without strict respect for authenticity. Many eastern coaches have been repainted and remodeled to conform to a western prototype, and their history and integrity as artifacts have been permanently altered or distorted. Alarming numbers of historic vehicles were destroyed from overuse for television and movie productions of Westerns.

The Museums' Concord coach was donated by Webster Knight II in 1962. Its serial number, 124, corresponds to the Abbot-Downing Company order book (1866)<sup>3</sup> that records the following description:

*Figure 1*  
Overall view of the Museums at Stony Brook's Concord coach before treatment, proper left side.



One Nine Passenger Stage Coach 3 seats inside 3 on a seat middle seat  
3 fold. . . . Paint Body Green Carriage Straw Letter "Allen House" (on Top  
Rail) "Sam Allen & Son" (on false sill to foot board) Neat ornament on Door &  
Foot board panel No border but striped. Same as City Coach Lined Russet  
Lea(ther) Lined. Damask head & fringe En. lea(ther) Curtains Damask lined  
Leather apron. Top and Rack Canvas. Done sure (completed) June 1st 1866"

The coach was used by Charles E. Fuller, who worked as a stage driver from 1865 to 1882 for the Fall River Stage Line and Pauldings' Express, both of which were based in New Bedford, Massachusetts. Between 1883 and 1901, Fuller was the proprietor of the Mattapoissett Stage Line, also in New Bedford. It is believed that during this time period, the coach was acquired secondhand by Fuller, and the body was repainted its current straw color. This was enhanced on the body panels by broad striping of black and Indian red. Finer striping of green and red traced the broader striping. The paintings on the door panels depicted a lighthouse and a seascape on one door and a stagecoach under attack by Indians on the other. This ornamental painted surface is typical of the artistry applied to coaches and other public or commercial vehicles.

Unfortunately, the Museums' coach had suffered from outdoor exposure, most likely during a time of abandonment when the importance of such vehicles as cultural artifacts had not yet been recognized. The coach underwent conservation treatment between 1991 and 1993 at the Fremont, New Hampshire, studio of American Conservation Consortium, Ltd.

---

## General Conservation Concerns

A primary concern in the conservation treatment of a horse-drawn vehicle is the determination of the historic presentation surface. Does the original painted surface survive? Do later paint schemes relate to the historic period of use? Is relatively recent repainting important or significant? Ideally, these sorts of determinations are made by the curator, if the vehicle is owned by a museum, after reviewing the results of analysis and testing. However, if the vehicle is privately owned, the conservator often must function in a quasi-curatorial role, attempting to guide the preferences of the owner toward a responsible choice.

Once a determination of the historic significance of each paint scheme is made, the condition of each of these layers can have an important contribution to the design of a treatment. A later repainting that remains in good condition may be preferred as the aftertreatment presentation surface. Remember, the vehicle was repainted for a reason. Often, this was due to degradation of the earlier layers. In addition, earlier layers may have been damaged in the surface preparation for the newer paint. Of course, exposing an earlier layer will require destruction of the later, but still historically important, paint.

A final consideration is the technical feasibility of removing later layers from earlier ones. Often, the materials used are very similar in their composition. Separating a more recent sandarac-based paint layer, for example, from a similar earlier one can be extremely tedious and prohibitively expensive, or even technically impossible. Since the vast majority of surviving horse-drawn vehicles dates from after 1850, the diversity of materials used in their decoration leads to equally diverse conservation challenges.

## Conservation Treatment

The Museums at Stony Brook's Concord coach presented many of these challenges. While the coach was in rather good structural condition, its surfaces were both degraded and complex. To the eye, it appeared that two complete paint schemes survived from the period of use. There were also several repaintings of specific areas that were of uncertain time periods. Paint crazing, cleavage, and loss were extensive, particularly on the running gear. The surface varnish layers were embrittled, discolored, and friable, lending the coach body an uneven orangy appearance. Was this color due to the effect of aging of the coatings or did it represent an intentional coloration or glazing by the painter?

To assist the curator and the conservator in understanding the history and sequencing of the layers, as well as to provide technical insights into the painting materials, seven small paint samples were taken for microscopic examination. The samples were taken at the edges of existing losses to minimize the aesthetic impact. They were mounted in resin cubes, polished, and examined by means of fluorescence microscopy by Richard Wolbers.<sup>4</sup>

Photomicrographs and a report of the analysis permitted several significant determinations to be made. They confirmed that the body of the coach had been painted twice during the period of its historic use. Primer layers were inconsistent from one sample to another, but they appeared to be black over blue over light red. This concurred with the shop tradition of using as a primer whatever color was left over from another job. The earliest body color was a dark (almost black) green. This corresponded to the description of the coach in the Abbot-Downing order book when it left the factory. On top of this green were six varnish layers, each with characteristic weathering fissures and entrapped dirt, indicating that they each had been separated by an interval of time. A thick layer of straw-colored body paint was found directly over the sixth layer of varnish, and it had penetrated into the fissures. Six more weathered varnish layers were applied over the straw-colored paint. There was no evidence of revarnishings or repaintings after the period of use (Fig. 2).

The cross sections revealed that the six most recent varnish layers over the straw-colored paint did not contain pigments or other colorants. Therefore, it was concluded that the orangy color was due to weathering, aging, and discoloration of the varnish layers, and that it was not intended by the coach painter. The nature of the varnish layers and the nature of the striping were very similar, both identified as natural plant resins in the cross sections.

Three of the samples related to specific areas of the coach body. The sample taken from the green border of the seascape medallion on the central panel of the door shown in Figure 1 indicated that the medallion was painted on top of five of the varnish layers over the straw-colored paint. The sixth varnish layer was applied over the medallion, indicating that the medallion was added near the end of the period of use of the coach. It also indicated that special care needed to be taken around the medallions during treatment, as any solvent that would remove the varnish layers would also remove the paintings on top of the varnish. While a sample was not taken from the stagecoach medallion, it appeared to have been applied at the same time and in the same manner as the seascape medallion.

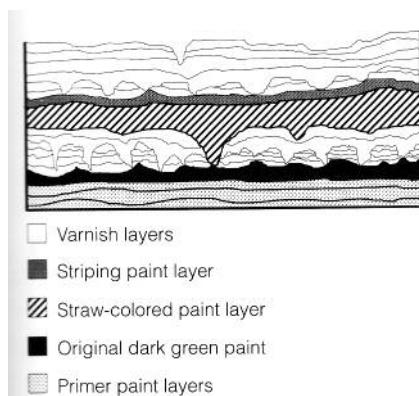

*Figure 2*  
Schematic diagram of cross section viewed in UV light, from an area of red striping on the Stony Brook Concord coach. Note the original paint on the bottom, with six weathered varnish layers over it, then the thick straw-colored paint, over which are the striping and six more weathered varnish layers.

Visual examination in combination with the cross section from the driver's seat riser showed a gray primer beneath dark green paint that was consistent in color with the rest of the body. On top of the green paint was a slightly transparent red paint that appeared to be in a varnish medium. An eagle was painted over the red layer at the center of the panel. Two orangy varnish layers were applied over the red paint and eagle. Visual observation showed three faint striping lines around the perimeter of the riser panels. These were on top of the dark green paint layer but beneath the red layer. All of the layers on the riser appeared to date from the historic period of use. However, it was not possible to determine exactly when the red paint was applied. It was clear that it did not exist at the time of manufacture, since it obscured the original green paint and striping.

The sample from the top frieze lettering, "MATTAPOISETT AND NEW BEDFORD," showed multiple layers of paint, indicating that the names had been repainted a number of times. Colors included yellows, reds, blacks, blue-greens, and whites. It was not possible to establish a comprehensible sequence of lettering and backgrounds from the sample.

The cross section taken from a wheel spoke on the proper right side indicated that eight straw-colored paint layers existed. While there were some slight variations of the shade of straw, this represented a conscious attempt to maintain the same running-gear color throughout time. Each of these layers had its own unique striping pattern, both in design and color, varying primarily from brown to black. One to three weathered varnish layers were over each paint layer, all appearing to belong to the historic period of use. Losses in the paint layers penetrated to different depths, and each subsequent repainting flowed into these losses. This created its own set of treatment concerns.

The information gathered from the paint samples suggested several general treatment approaches that were discussed by the curator and the conservator. A primary consideration in the treatment of the coach was the discovery, interpretation, and presentation of the various paint histories. Since all of these dated from the period of historic use of the coach, all had valid historic integrity. Unfortunately, it was not technically possible to reveal earlier decorative surfaces without destroying the later overlying paint. This paradox is common to many horse-drawn vehicles, as well as to other painted decorative objects. The history of changes in decorative preferences throughout time can be, in itself, as significant as the original appearance of an object.

Several potential solutions existed for the coach. First, it could have been stabilized only and preserved in its pretreatment condition; however, the existing mottled orange color was created only by the discolored varnish over the straw-colored paint. This was not an intentional effect, and it greatly distorted the appearance of the coach as it had been when owned and used by a known historic figure, Charles E. Fuller. A second option was to return the coach as closely as possible to its appearance when used by Fuller. This would have required removal of the degraded upper varnish layers and inpainting of losses into lower layers to fully re-create the straw-colored paint scheme. A third choice was removal of all of the six upper varnish layers, the straw-colored paint and the six lower varnish layers to reveal the original dark green paint on the body—a solution that appeared to be technically feasible. However, the straw-colored paint corresponded to ownership and use of the coach by Fuller; this layer

was in relatively good condition, and the overall condition of the lower green layer was unknown. Although the coach could have been photographed before treatment in extreme detail, this approach would have destroyed the straw-colored paint history. A fourth option that fell midway between the latter two was to preserve the straw-colored paint on one side and expose the green paint on the other side. A partial history of the straw-colored paint would have been preserved, but the coach as a whole may have appeared disjointed, and this option would clearly have been inaccurate as a representation of the coach's actual appearance when in use.

The approach that was chosen was a variation on the second option. The later degraded varnish layers were removed. Areas of natural wear were preserved, however, complete with naturally revealed earlier decorative paint. In addition, several "windows" were opened into earlier layers at appropriate locations, while still preserving the overall unified appearance of a straw-colored coach.

The first treatment step taken after analysis and photography of the coach was the setting down of loose and lifted paint. On the running gear, this was done with dilute, hot hide glue brushed around the entire circumference of loose areas and losses with an artist's brush. This was chosen because the paint layers in composite were quite thick and stiff, and a strong adhesive was needed. Loose paint on the body was reattached with Acryloid B72 (approximately 20% in toluene). B72 was selected due to its reversibility, stability, thermoplasticity, and workability. Where necessary, lifted paint was set down with gentle pressure from a heated spatula and tacking iron. However, many of the lifted areas of paint overlapped neighboring paint due to shrinkage of the wood beneath it. It was not possible to return paint in such situations back to plane. This was most prevalent on the wheel spokes.

With the painted surfaces stabilized, the next treatment step was the removal of the six degraded varnish layers over the straw-colored body paint. These natural plant resins were soluble in many organic solvents, including denatured alcohol and acetone, as well as abietic acid soap. This implied that they were rather pure resins without the addition of potentially cross-linking components, such as oils. Unfortunately, while the varnish was readily soluble, the varnish layers beneath the straw-colored paint were equally as easily dissolved. As the solvent reached the straw-colored paint surface, it penetrated to the underlying varnish through the extensive cracks and crazing in the paint, removing the straw-colored paint at the crack edges. Even the use of gelled solvents did not prevent this problem. A second concern was that the narrow red and green striping on top of the straw-colored paint was executed using a similar varnish-based medium. As the surface of the straw-colored paint was reached, the striping was in danger of being dissolved along with the overlying varnish.

Initially, alternating applications of denatured alcohol and acetone on cotton pads and swabs were used to remove the body coating. This proved to be less than satisfactory, however, as the length of time the solvent needed to remain on the surface to dissolve all six varnish layers also caused a slight softening of the varnish beneath the straw-colored paint, with subsequent paint loss. The only alternative was to leave part of the discolored varnish in place over the straw-colored paint. This resulted in a perceptibly mottled color due to varying varnish thickness. The appearance was judged to be acceptable by the curator but was not ideal. Continued experimentation indicated that better results could be obtained



with a more aggressive solvent that removed the varnish much more quickly. Thus, less manipulation of the surfaces was required and the solvent was in contact with the surfaces for a much shorter time. Use of an aggressive solvent allowed more complete removal of the varnish layers with less disruption through the crazing. The solvent *n,n*-dimethylformamide (DMF) proved to be highly effective and was used for varnish removal on the coach body.<sup>5</sup> Varnish layers on the narrow horizontal panel below the rear window on the proper left side were not removed but were allowed to remain undisturbed as a record of the pretreatment condition of the coach (Fig. 3).

Since the red and green striping on the body panels had been applied in a varnish medium similar to the varnish layers that were removed, special care was required. A band of varnish on and around the striping was left undisturbed during the overall varnish removal with DMF. Varnish was removed extremely carefully from the striping with denatured alcohol on swabs. Residual varnish was left in place rather than risk loss of the striping by attempting to remove all of the varnish. The color shift caused by the remaining varnish was unobtrusive. This process was extremely tedious and delicate but was successful in preserving the striping, while also creating a harmonious appearance of the coach body.

The painted medallions on the door panels had been applied on top of five of the six varnish layers. Therefore, a border of about half a centimeter of varnish was allowed to remain around the medallions. This was done to prevent solvent from softening the varnish beneath the paint due to capillary action, which would cause paint loss. The final border of discolored varnish around the panels was removed mechanically with a scalpel. The presence of the five layers of discolored orange varnish beneath the medallions somewhat distorted the paint colors, especially in areas of crazing. Fortunately, the distortion was very minor and was visually acceptable, as there was no known method of treatment to remedy this problem.

Tests of varnish removal on the running gear were not successful. Processes that removed the darkened varnish layers also removed the striping. This was due in many areas to the presence of striping on top of the

*Figure 3*

Detail of the proper left rear of the coach after treatment. The degraded varnish was left intact on the narrow panel. Also, a small "window" was opened to the earliest dark green paint layer.

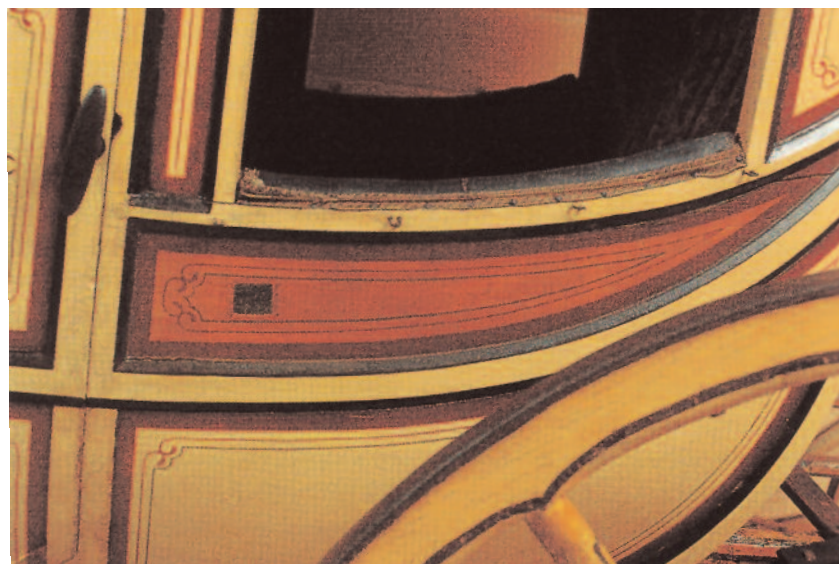

varnish. Another contributing factor was the numerous layers that were concurrently exposed, allowing solvents to work on lower, exposed varnish layers and removing paint above them. For these reasons, the varnish layers were left intact on the running gear. The relatively undistorted straw-colored paint color, due to fewer varnish layers on the running gear, harmonized with the body color of the coach after its varnish was removed. Running gear surfaces were cleaned with distilled water on cotton pads and swabs. This was chosen in preference to a detergent because it would not leave behind any residue that required rinsing. The unevenness of the surfaces would have made rinsing detergent residues very difficult. In addition, tests indicated that cleaning with distilled water alone was as effective as cleaning with a detergent. The varnish was removed with DMF in limited areas where the varnish layers were thicker and created darker orange discolorations.

Two coats of B72 in toluene (approximately 20%) were brushed onto the painted surfaces of the body and running gear. These served as an isolating barrier to separate inpainting and later protective varnishes from the original surfaces. In addition, it consolidated areas that suffered from fine crazing and potential paint insecurity. B72 was chosen not only for its well-known properties of reversibility and stability but also because it was insoluble in mineral spirits—the intended solvent for the protective varnish to be applied in a later treatment step.

Paint losses were inpainted with artists' acrylics by Nancy Garrison, a decorative painting specialist. These totaled thousands of areas. After the approximate base color was applied, each area was toned individually to harmonize with the subtle nuances of color surrounding it. This was particularly complex on the running gear, where previous losses and repaintings to both the paint and varnish layers had created a multitude of shades. As requested by the curator, lower decorative paint that showed through, including striping, was not inpainted. This created a slight patchwork effect, but allowed a glimpse into earlier paint histories. In addition, areas of natural wear from use were not inpainted.

As a final protective coating on all painted surfaces, two coats of Acryloid B67 (approximately 20% in mineral spirits) were brushed on. B67 was chosen specifically to provide a solubility that was different from the B72, thus allowing for its future removal, while leaving the B72 undisturbed. In addition to protecting from dust and dirt, this coating optically saturated the paint colors of both the original paint and the inpaint. It created a gloss that approached the original level, although the effects of crazing and losses of the paint resulted in a surface that was less smooth and probably less glossy than a factory finish. Since the coach was now a museum artifact that reflected both its previous use and the passage of time, this was an appropriate presentation appearance.

Several "windows" were opened at strategic locations on the coach. On the proper right side, a "window" exposed the lower layers of the frieze between the letters W and B of "NEW BEDFORD." The most recent lettering was light yellow on a darkish red background. Beneath this could be seen the ghosted image of a previous application of "NEW BEDFORD" in a slightly different location. Removal of the latest paint revealed a bright orange-yellow letter on a black background. Further removal showed a lower layer of a straw-colored letter on a darkish red background. It was not possible to determine which letters were present, as only a small area was visible.

A small square “window” was opened with denatured alcohol through the straw-colored paint and underlying varnish layers to the dark green paint on the narrow panel beneath the rear window of the proper left side, which had had its varnish layers left intact. The green paint was heavily weathered, with straw-colored paint in the network of weathering fissures (Fig. 3). Although it could not be confirmed that the paint over all the surfaces was in the same condition, this discovery supported the decision not to remove the straw-colored paint in an attempt to return the coach to its earliest appearance.

The window units in the doors of the coach had ghosted pinstriping beneath a black surface paint. In areas of wear, it was apparent that the original dark green paint was present beneath the later black paint. The black paint was removed from the outside of the proper right window. The revealed off-white striping was in good condition. Also discovered was broader black striping around the perimeter of the door, as well as around the perimeter of the panel. This was in subtle contrast to the dark green background.

A “window” was opened on the proper left driver’s seat riser to reveal a complete pattern of the lower dark green paint with striping (Fig. 4). The newly visible paint was in surprisingly good condition. The central of the three striping lines was a red color, with the outer lines white. During examination of the seat riser for treatment, a barely perceptible raised image of “U.S. MAIL.” was discovered on the bottom of both sides of the seat riser beneath black paint. The black paint was removed to reveal yellow letters on a dark green background. Beneath the current “U.S. MAIL.” was a ghosted image of an even earlier version of the same lettering.

The upper paint layers on the running gear were removed on the two rear panels flanking the center of the rear axle (Fig. 5). The proper left panel showed the second most recent paint sequence and was marked with a small “2” in artists’ acrylics. The top of the proper right panel was the paint on the third level beneath the surface (“3”), and the bottom of this panel was the fourth level (“4”).

*Figure 4*  
Detail of the proper left driver’s seat riser after treatment. The lettering “U.S. MAIL.” was discovered beneath black paint. In the lower right corner, the red varnish-based paint was removed to show the original dark green paint and striping.

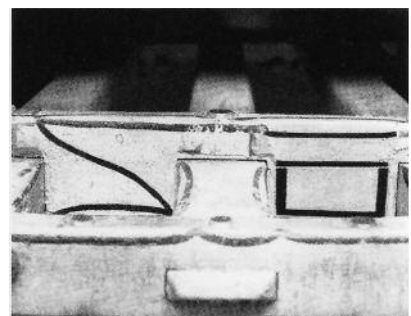

*Figure 5*  
“Windows” were opened into the second, third, and fourth paint layers from the top on the rear axle, revealing their unique striping patterns.

Figure 6

Overall view of the coach after treatment, proper right side.

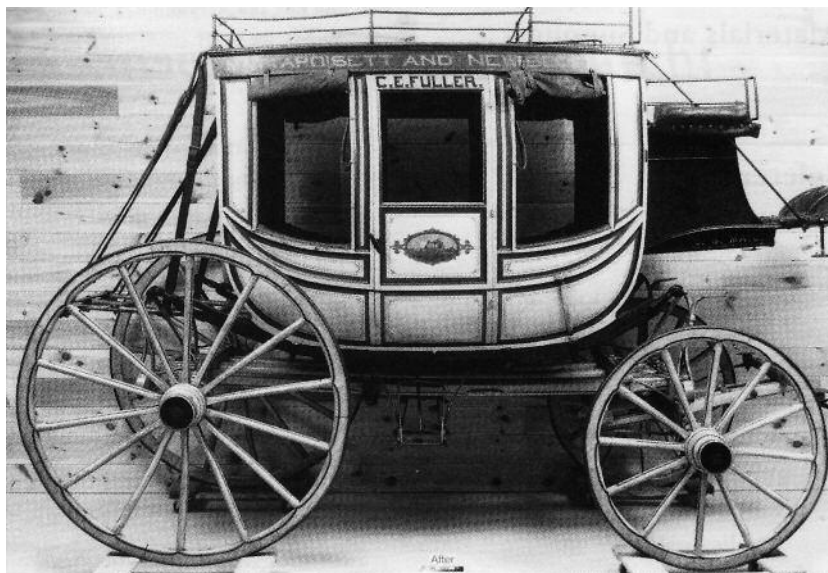

---

## Conclusion

The conservation treatment of the Concord coach was successful in meeting its objectives. The surfaces of the coach were stabilized, a more accurate historic presentation appearance was provided, information about previous surface histories was gathered, and glimpses of the earlier decorative paint schemes were revealed (Fig. 6). The success was a result of effective communication between the conservator and the curator.

Analysis and testing provided information on which decisions could be based. In addition, unexpected discoveries were made, which required further discussion and the choosing of alternatives. Rather than an exception, this experience appears to be common in the treatment of horse-drawn vehicles. The diversity of materials used and the varying repainting and pretreatment conditions of such vehicles create an endless range of treatment needs and options, which is responsible for both the anguish and the joy of working on these unique cultural artifacts.

---

## Acknowledgments

Funding for the conservation treatment of the Concord coach was made possible by a Conservation Project Support Grant from the Institute of Museum Services (a federal agency), and contributions from Mrs. J. Cecil Ferguson, Mrs. F. Henry Berlin, Leighton H. Coleman, John E. Day, the Concord Coach Society, and American Conservation Consortium.

---

## Notes

- 1 The majority of the reference books for this article are from the Carriage Reference Library at the Museums at Stony Brook.
- 2 Much of the information for this section was taken from the writings of Edwin Burgum, the son of the ornamenter. New Hampshire Historical Society, Archives and Manuscripts, Burgum Papers, ca. 1939.
- 3 The authors are indebted to Jim Wilke for providing this information.
- 4 Richard Wolbers, 4 Furness Lane, Wallingford, PA 19086. Wolbers is one of the pioneers of selective staining of paint/varnish cross sections to allow not only for determination of stratigraphy, but also for gross material characterization.
- 5 DMF and most other organic solvents are toxic. Appropriate safety precautions should be used, including ventilation, respirators, and gloves.

---

## Materials and Suppliers

**Acryloid B67 and Acryloid B72**, Rohm and Haas Co., Independence Mall Street, Philadelphia, PA 19105.

---

## References

- Abbot-Downing Company**  
1866 Order books, 1858–1902, 1 June 1866. New Hampshire Historical Society, Archives and Manuscript Division, 30 Park Street, Concord, New Hampshire.
- Brewster and Company**  
1897 Painting prices—1897. Brewster and Company inventory, Rare Books and Manuscripts Division, New York Public Library, New York.
- Burgess, J. W.**  
1881 *A Practical Treatise on Coach Building*. London: Crosby Lockwood.
- Ferrell, Merri M., ed.**  
1983 *The Coach Painter 1880*. New York: New York Exposition Press.
- Gardner, Franklin B.**  
1875 *The Carriage Painter's Illustrated Manual*. New York: S. R. Wells.  
1885 *How to Paint*. New York: Fowler and Wells.  
1905 *Everybody's Paint Book*. New York: M. T. Richardson.
- Houghton, George W. W.**  
1871 Gum copal. *The Hub* 13.  
*Hub, The*  
1878 The perishing of varnish. *The Hub* 20(September).  
1888 Color nomenclature. *The Hub* 30(September).  
1889 Three sources of beautiful colors. *The Hub* 31(August).  
1893 *The Hub* 35(June).
- Maire, Frederick**  
1908 *Modern Pigments and Their Vehicles*. New York: John Wiley and Sons.  
1911 *Modern Carriage and Wagon Painting*. Chicago: Frederick Drake.
- Masury, John W.**  
1871 *The Carriage Painter's Companion*. New York: John W. Masury.  
1881 *House-Painting, Carriage-Painting and Graining*. New York: D. Appleton.
- Philipson, John**  
1897 *The Art and Craft of Coachbuilding*. London: George Bell and Sons.
- Schriber, Fritz**  
1891 *The Complete Carriage and Wagon Painter*. New York: M. T. Richardson.
- Shinnie, Robert**  
1902 1896 carriage painting. *Papers Read before the Institute of British Carriage Manufacturers, 1883–1901*. Aspley Guise, England: Dowager Press.
- Vanderwalker, F. N.**  
1917 *Automobile Painting and Carriage and Wagon Painting*. Chicago: Frederick J. Drake.

# The Importance of Conservation to Research: A Case Study

Merri M. Ferrell

THE GRACE DARLING, an omnibus 7 m long, was also called a barge because of its size (Fig. 1). The largest vehicle of this type, the *Pride of the Nation*, was 11 m long. These types of public conveyances were used in urban and resort areas in the United States to transport large numbers of people and were decorated profusely with ornamental, painted motifs, such as landscapes, scrollwork, striping, and other popular pictorial motifs. It was a common practice to name vehicles used for public transportation; similar vehicles included the *Concordia*, the *Pride of the Nation*, and the *Hiawatha*. The *Grace Darling* was named after an English lighthouse keeper's daughter who was instrumental in the 1838 rescue of survivors of the shipwrecked *Forfarshire*. Grace became a national heroine in England. Her fame precipitated many forms of commemoration—from poetry to pottery—and her name was applied to steamships, locomotives, and horse-drawn carriages.

The *Grace Darling* was built around 1880 by the Concord Carriage Company, a carriage-making firm that occupied the old state prison shops in Concord, New Hampshire. The firm was listed in *The Leading Business Men of Concord* as the manufacturer of “Heavy Trucks, Wagons, Caravans,

Figure 1  
Overall view of the omnibus *Grace Darling*,  
built ca. 1880 by the Concord Carriage  
Company, Concord, N.H.

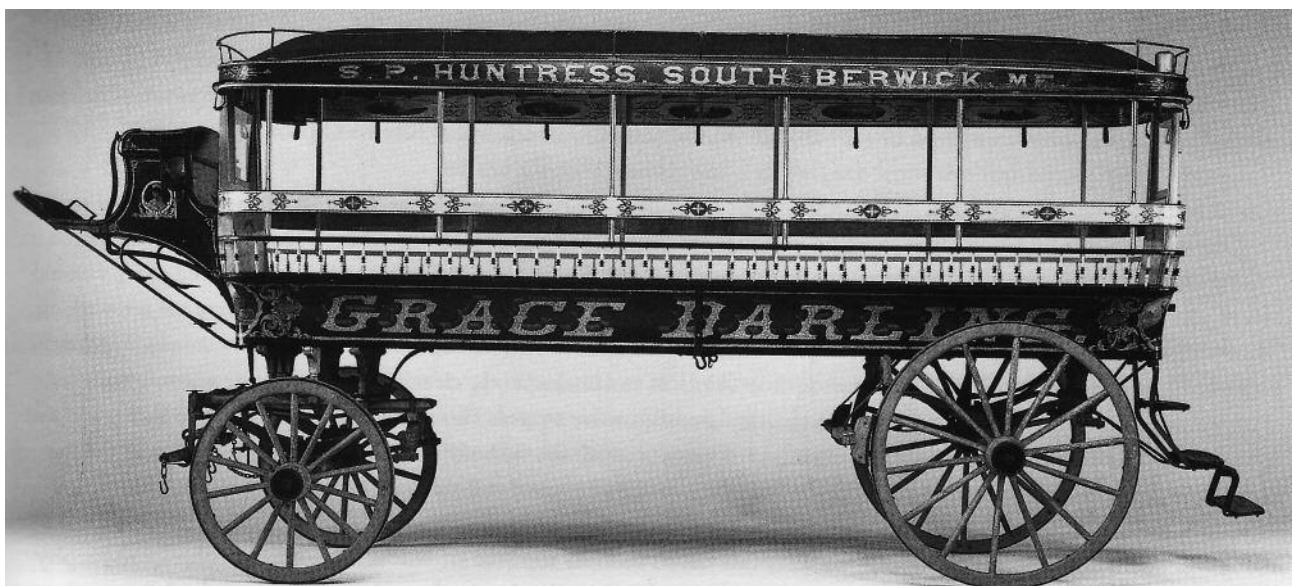

Barges, Furniture, Job and Express Wagons” (Bacon 1890). The company was in business for fifteen years (1875–90), a relatively short time for a carriage-making establishment. The firm employed some of the more skilled or specialized workers from the Abbot-Downing Company. The Grace Darling was made for and used by Simeon Parsons Huntress (1846–1923), who operated a livery service from the 1880s to 1904 in South Berwick, Maine. The vehicle was listed in the *Dover (Maine) Enquirer* (1880) as a “six horse passenger barge of S. P. Huntress of South Berwick. It bears the name of Grace Darling, and will accommodate 45 persons, it is on easy springs, is beautifully painted and richly upholstered. It is to be used for beach or excursion parties, and can be had at reasonable rates.”

The Grace Darling was acquired in 1925 by Saint Paul’s School, a preparatory school in Concord, New Hampshire, which used the omnibus for many years as a means to transport athletic teams to local sporting events and other school functions. In 1952, the vehicle was donated to the Museums at Stony Brook, New York (then the Suffolk Museum and Carriage House), through the efforts of its curator, Richard Gipson, and Saint Paul’s faculty member Coolidge Chapin. Museum records from 1952 to 1982 attribute the manufacture of the vehicle to the Abbot-Downing Company, also in Concord, a firm that was famous for making overland vehicles such as stagecoaches. It remained in storage for more than thirty years, during which time a continuous debate concerning its relevance to the collection and its restoration ensued among museum staff members. As early as 1953, curator Richard Gipson was asked to improve the appearance of the piece through total restoration. He advocated the preservation of the original painting and materials on the barge, as well as on other vehicles in the collection. His reply to this persistent request was (Gipson 1953a):

You did tell me that you thought it might be better to clean down the barge and start over again. However, this is a very expensive operation in the first place, and I fear that, in a carriage of this character, we may be seriously injuring its antiquarian value and impairing its antiquarian interest.

There are no records identifying the type of solvent Gipson used, although he did report to his supervisors that after “much experimenting” he had found a way to preserve the paintings on the barge (Gipson 1953b).

By 1961, Gipson had retired and moved to Vermont. His successor, George Isles, continued the debate concerning the restoration of the paintings on the Grace Darling. He wrote to Gipson (Isles 1963):

We have the barge “Grace Darling” at Wood farm. As you know, the paintings, scrollwork, and lettering are the work of an artist, the like of which it would be very difficult if not impossible to have reproduced today. I would very much like to restore or perhaps I should say preserve the art work on this vehicle. Some of the paintings and scrolls are badly damaged and more will be lost or damaged in the cleaning. The undergear was originally red and probably richly striped. This should be cleaned down to bare wood and redone as original. On the body the paint could be removed from the seat up and lettering and striping re-done as original.

Correspondence refers to the size of the vehicle as a “problem” (Murphy 1973). It was too large to display in the existing museum building and costly to store. At that time, the vehicle was kept in a shed off-site and was

eventually moved to renovated lumber sheds that were adapted in 1976 as permanent on-site storage for the carriage collection.

In 1982, a committee of consultants was engaged to evaluate the scope and content of the carriage collection as part of a five-year plan associated with developing interpretive exhibitions for a new carriage museum. In keeping with a growing trend in the museum profession, the retention of only “typical” artifacts that reflected “normative patterns of ownership and use” was advised. Curatorial opinion was based on collections’ survival, as well as on the preservation of documents referring to the production and use of a class of objects, without considering earlier prejudices that may have led to the wholesale disposal of a quantity of similar objects that would posit the few existing artifacts in a classification deemed “typical.” The mere size of the Grace Darling, as well as its profuse ornamentation, seemed extraordinary and atypical; a recommendation followed to dispose of the vehicle. The recommendation was not followed, and research was conducted to justify retaining this type of vehicle. The research revealed that thousands of these types of vehicles were made and used for public transportation, but as their usefulness abated, the desire and means to retain them and the respect for them as artifacts diminished. The size of these objects—and particularly the expense and the amount of space required to store them—as well as their obsolescence and their demoted status as useless nonart, contributed to their destruction. The famous Pride of the Nation, made by John Stephenson, was hitched to a tractor during the 1920s and pulled around the country as a type of sideshow object until it eventually disintegrated. Another example, the Maplewood, had its pillars and roof sawed off to fit it through a low doorway in a storage facility. Many other carriages either were left outside to disintegrate or were simply destroyed. This type of object thus became rare not because few were made but because so many were destroyed, and the records of the industry documenting their manufacture and use were discarded or lost. The dearth of these types of artifacts and their societal and technical function also have been misinterpreted, thus further influencing institutional commitment to acquisition and preservation.

---

### Advocacy for Conserving Horse-Drawn Vehicles

Through research, the Grace Darling was identified as a significant vehicle type, and this influenced the decision to place it prominently in the new carriage museum. To prepare the vehicle for exhibition and to improve its appearance, it was decided that it should be conserved. The conservation of the Grace Darling was a departure from the more common practice of restoration. The term *restoration*, when used by carriage collectors or restorers, means the removal of original materials and the replacement of those materials with modern equivalents. This practice, whether by default or intention, results in a series of compromises based on the availability of materials and the interpretation of fabrication methods, as well as the application of these components to specific vehicles. The profession of carriage restoration is crowded with amateurs ill-equipped to interpret the objects they restore. If carriages were simply constructed craft objects manufactured by hand, the reproduction of parts and materials would be relatively easy to accomplish. Carriages were, however, complex, composite objects created by an industry composed of subdivided labor and sub-industries that supplied the primary industry with metal and wood parts, fittings, textiles, and other materials. The majority of horse-drawn vehicles



in American museums today were made and used during the last half of the nineteenth century. They were manufactured in factories, and the specialized machinery and conditions of manufacture are difficult, if not impossible, to reproduce. The woodworking machinery used for the body and undercarriage, the large Jacquard looms used for weaving thousands of yards of coach lace, and the mass production techniques and patterns for the manufacture of malleable cast iron parts are no longer available. Because the primary industry is no longer viable, the multiple sub-industries that produced the auxiliary products were also phased out. Restorers are challenged to find compatible materials and to interpret the existing materials on their vehicles. It is typical for the silhouette to be preserved but for the original materials to be destroyed. By subtracting construction details and original materials from the general body of preserved material available for study, the restorer robs the vehicles of significant historical content, diverse expression, original aesthetic intention, and mechanical ingenuity. Unfortunately, third- and fourth-generation restorations have become the standard by which the authenticity of horse-drawn vehicles in original condition are measured.

Vehicles in original condition speak volumes about the technical and aesthetic details expressed by carriage manufacture. The details that are preserved reveal much about their fabrication, as well as the tastes of the designer, finisher, or owner. Carriages, like other objects that represent the material culture of a particular period, offer complex information on the general aesthetic of the people who made and used them. The types of materials—from textiles to interior fittings—that were used in constructing an individual carriage are part of its aesthetic. Carriage painting, ranging from simple color application and striping to complete pictorial programs and gold-leaf scrollwork, was an important aspect of the trade. Painting protected the wood and metal structure and unified or emphasized the various parts and materials, giving the vehicle its overall aesthetic character. As recorded in the Henry Baird publication *The Painter, Gilder, and Varnisher's Companion* (1870:20), "in ornamenting and striping a carriage, it requires considerable taste and judgment . . . to preserve and show in the most graceful manner the workmanship of the builder."

Carriage painting was a specialized skill and an integral part of the larger system of carriage manufacturing. Prospective painters entered the trade as apprentices and became familiar with their materials through the repetition of rigorous tasks, such as grinding pigments, preparing surfaces, and applying and rubbing down successive coats of varnish. Additional instruction in the trade was available through technical schools and numerous instruction manuals and periodicals that were published for the industry. Instruction could vary from practical topics—such as recipes for "rough stuff" or filler, or processes for applying color and varnish coats—to advice on how to keep the painted surface glossy and smooth. Aesthetic instruction was available in written descriptions, accompanied by printed images, of an array of decorative devices that offered painters a rich vocabulary of ornamentation to apply to sleighs, wagons, and commercial and public vehicles.

Nineteenth-century carriage ornamentation was as varied and as eclectic as decorative arts. In particular, commercial vehicles were elaborately decorated in order to satisfy their dual function as mobile advertisement and conveyor of goods and services. One author (Hillick 1906:109) wrote that painting trade vehicles was

a limitless art, resourceful, restive, responsible to an admirable degree to the ever-varying side lights of technical skill. All that art can be anywhere the broad surface of the modern business vehicle invitingly offers to display. Its worth as an advertising medium, as an agency through which business stability and enterprise may be widely heralded, has been fully learned. Thus the evolution of the present elaborately painted and decorated business wagon has come about.

Vehicles were decorated with simple or elaborate designs, striping, and borders in various styles: letters; numbers; faux finishes imitating caning, wood, or plaids; landscapes, people and animals. Within the profession of carriage painting, the ornamental painter was the highest paid and most respected because of the skill and specialization of his trade, and commercial vehicles offered the best opportunity to show the painter's artistic abilities. In describing the requisites of the commercial vehicle or "wagon" painter, M. C. Hillick (1906:110) wrote,

He must know well how to build a beautiful and durable surface. He should be a first-class colorist, understanding all the features of color mixing and fully conversant with the lays of harmony and contrast. He will likewise find it necessary to be an unexcelled master of the varnish brush, a skilled striper, wagon letterer, and decorative painter of established ability.

Unfortunately, because of contemporary attitudes about horse-drawn vehicles—which are influenced by factors such as size, obsolescence, or utilitarianism—examples of carriage painting have perished due to neglect or to total restoration. The artistry of the decorative surface of the Grace Darling omnibus had been acknowledged since the *Dover Enquirer* first recorded its service in 1880, but total restoration had been considered numerous times since the acquisition by the Museums at Stony Brook.

---

## Conservation Treatment of the Omnibus

The Grace Darling omnibus was structurally sound and did not require physical stabilization. However, much of the detail of the paintings was obscured by layers of the historic varnish and successive layers of various coatings and dirt that had accumulated for decades. The first challenge of the project involved finding a conservator who would work on an object of this type. The size of the vehicle required conservators to work on-site in less than ideal conditions in a storage shed. Numerous interviews with painting and objects conservators were conducted before a professional conservator willing to work on the Grace Darling was secured. All candidates supported the project in theory, but were unwilling to undertake the work. In 1983, the Museums at Stony Brook contracted with Fine Objects Conservation—a group of conservators and assistants supervised by Linda Merk-Gould—to perform the work. The first step of treatment was to identify a solvent or combination of solvents to remove the accumulated layers of varnish, shellac, linseed oil, and grime from the original paint, without disturbing the glaze coats of transparent pigments that contributed to the unmistakable depth and hue of the vehicle's painted surfaces. These layers had combined over the years to form a dark, reticulated surface that did not respond to initial solvent testing. Paintings conservator Rustin Levinson assisted in this phase of the project. Cross-sectional analysis was not used at this time.

Figure 2

Detail of the painting on the Grace Darling. Shown are the letter G and scrollwork on the proper left side after conservation.



Figure 3

Detail of female figure painted on the proper left side of the seat in the Grace Darling, after conservation.

Conservation treatment produced dramatic results. The presentation surface of the lettering before conservation was dull and monochromatic. The background color appeared to be dark brown, and the letters a drab green. After treatment, the brilliant blue and gold leaf of the double block letters were visible, as were the subtle highlights, glazing, and shadings that gave dimension to the lettering (Fig. 2). The accuracy of the color that was evident after conservation was an important aspect of the project. If the vehicle had been restored, and the replacement colors had been based on what was visible before conservation, the entire color program of the restoration would have been inaccurate. Cleaning the darkened coatings showed the painter's skill of combining numerous colors to achieve a more pleasing effect. The border around the letters was gold leaf enhanced by a stripe of dark transparent red (carmine), which was accentuated by a fine stripe of dark brown. The figures on the seat risers had been barely visible prior to treatment. Removal of darkened coatings revealed exquisite painting of idealized young women in 1880s dress and coiffure (Fig. 3).

The paintings on the exterior of the rear door depicted a woman in mid-nineteenth-century costume with a bow and quiver, the latter being a reference to Huntress, the owner and operator of the livery service (Fig. 4). This painting was adapted from the central figure in John Sartain's (1808–97) engraving *Cheerfulness* (illustrated in *Memory's Gift* n.d.).<sup>1</sup> The adaptation of this engraving explained the dress of the figure, which was anachronistic to the vehicle. Below this figure was a small and beautifully executed painting of a stag and a hound. The interior pictorial program consisted of a bouquet of flowers and the manufacturer's name. Although the name of the maker, the Concord Carriage Company, was painted on the inside of the door, it had been totally obscured by multiple layers of darkened coatings; it was not until the coatings were removed as part of the conservation treatment that the actual origin of manufacture was known. After cleaning, the painting of flowers and the maker's name, framed in a decorative border on the interior of the door, were visible.

The rounded corners of the body of the vehicle were decorated with still-life and figurative paintings. The painting on the proper left rear corner medallion was an adaptation of Edwin Landseer's (1802–73) *Monarch of the Glen* (Fig. 5). The proper right rear panel depicted a hawk. The two front medallions represented a still life of fruit (proper left) and flowers (proper right). These paintings were framed in a broad gold-leaf border that incorporated shaded and highlighted scrollwork and various



Figure 4  
Overall view of the rear door of the Grace Darling, showing the lettering and vehicle number, and the figure adapted from John Sartain's engraving, *Cheerfulness*.

Figure 5  
Detail of proper left rear corner of the Grace Darling, showing the adaptation of Edwin Landseer's *Monarch of the Glen*.

forms of striping. The intricate red and blue striping of the undercarriage had been covered with yellow paint. This style of striping was popular from around 1875 to 1880 for business wagons. Patterns for this style of striping appear in numerous trade journals and painting manuals. The red and blue striping on the off-white undercarriage complemented the similar paint scheme on the seat rail.

### Uncovering and Preserving the Evidence

The interior paintings were obscured completely by dark varnish and other coatings. These paintings had not been detected until they were conserved. The paintings were divided by the roof pillars and consisted of a program of twelve landscapes and seascapes in ellipses framed by a gray, Eastlake-style border (Fig. 6). These paintings provided the first evidence leading to identifying the artist who painted the Grace Darling. Initial research for an exhibition on preeminent American carriage makers, that

Figure 6  
Detail of painting in the interior of the Grace Darling, after conservation. This is the work that led to identification of John Burgum as the carriage painter.

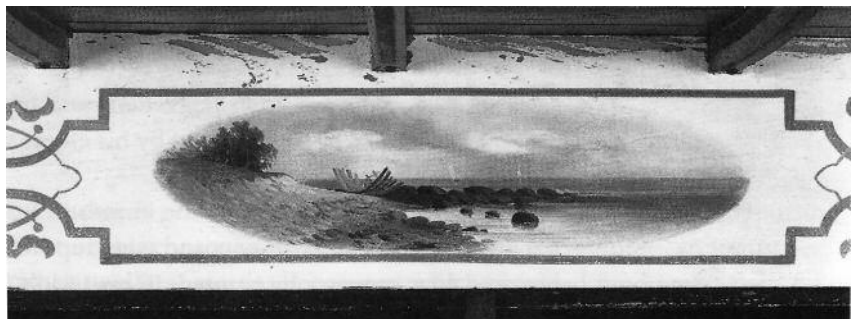

included the Abbot-Downing Company, led to the first encounter with the extensive archival holdings at the New Hampshire Historical Society.<sup>2</sup> During the review of the company records, the sketchbooks of John Burgum were consulted. Burgum's sketchbooks showed a series of sketches made in 1879 and 1880 of landscapes that were dated, with notes on the location. One particular sketch of a wreck was identical in composition and format to one painted on the interior of the *Grace Darling*. Unfortunately, this was not accepted as irrefutable proof of the authorship of the paintings, although labels and related museum texts written after this discovery attributed the paintings to him.

---

**John Burgum,  
Carriage Painter**

The *Grace Darling* was placed on exhibition in the carriage museum in 1987. In 1991, with funding assistance from the Early American Industries Grants-in-Aid program, researching the work of John Burgum continued. The archives of the New Hampshire Historical Society in Concord, New Hampshire, include the diaries, sketches, and paintings of John Burgum (1826–1907), who was the chief ornamental painter for the Abbot-Downing Company. Burgum was born in Birmingham, England. He served his apprenticeship with clock-dial painter Christopher Wright, who provided his early training as an ornamental painter. He came to the United States in 1850 and became a coach painter in Boston and in Concord, New Hampshire, where he worked for the Abbot-Downing Company (Camden 1982).

Burgum's diaries (1863–1900) chronicle his daily activities and expenditures. Some entries are accompanied by sketches. Burgum's primary occupation was with the Abbot-Downing Company, which specialized in trade, overland, and public vehicles that required extensive decoration as commercial vehicles. His diaries indicate that he expanded his trade to the painting and decorating of fire-fighting vehicles for the Amoskeag Manufacturing Company in Manchester, New Hampshire; the Concord Carriage Company and Harvey and Company, both in Concord, New Hampshire; and the Union Carriage Shop and Cobb and Company of Queensland, Australia. He also painted portraits, banners, and small paintings on rocks and shells, which he executed during summer camping trips to Rye Beach or the White Mountains in New Hampshire. In addition, he taught an art class to pupils who were mostly young women. He regularly visited the Boston Museum of Fine Art, where he derived considerable inspiration, as well as ideas, for his coach work. During his trips to Boston, he purchased art supplies and periodicals. He copied images found in lithographs or engravings onto horse-drawn vehicles. In his diaries, he referred to taking some of his images from published material as "hunting up designs." Others he painted from life. He also purchased a variety of painter's instruction manuals. He extended his ornamental painting to furniture, and his diaries record the painting of blanket chests, chair backs, and trays. In 1874, he became a member of the Art Association, and by 1878 he was assisted by his eldest son, Edwin, who also trimmed carriages and made sails.

Many of the images in Burgum's ornamental vocabulary became stock ornaments and were repeated on the vehicles, pebbles, shells, and canvases he painted. In his 13 July 1879 entry, he recorded that he made sketches of Little Boar's Head, the rocks at Major Stott's, and the wrecks

on the beach. Several of his designs and sketches from life were converted to prick patterns to be transferred onto vehicles. Among these were the local landscapes and places of interest that he sketched from life, as well as copies of the works of Edwin Landseer, especially *Monarch of the Glen*, which he painted on at least four vehicles. He often mentioned Landseer by name, such as, “worked down at the shop on foot board to Stewarts Hotel Coach, laid in Landseers group of dogs” (Burgum 1878). In the entries of his 1880 diary, he wrote (Burgum 1880):

- June 30, 1880—worked on the Barge 19 hours. Painted *Monarch of the Glen* on the corner and put the lights on one corner and painted flowers in another.
- July 7, 1880—worked on the Barge 10½ hours, finished the figures on the door and foot board.
- July 8, 1880—worked on the barge 9½ hours inside putting in landscapes and seaviews.
- July 12, 1880—A cool pleasant day. Finished *Huntresses* Barge, worked 4 hours on it. Edwin traced the ornament on the 5th wheel sized and gilded it. I put the first coat of asphaltum on.

This entry provided irrefutable evidence that John Burgum painted the *Grace Darling*. It was indeed a “Barge,” and featured *Monarch of the Glen* and flowers on its body panel corners. Landscapes and seascapes that were painted in the interior were clearly visible after conservation. The reference to “*Huntresses*” barge is a direct reference to Simeon Parsons Huntress, the name of the proprietor of the livery service who commissioned the manufacture and decoration of the omnibus.

It took John Burgum 142 hours to paint the *Grace Darling*. The vehicle was much admired during its many years of service, from its original function as a livery vehicle to its role as a conveyor of students and young athletes well into the age of the automobile. As a museum artifact, its preservation became an issue of debate, and the vision and advocacy of Richard Gipson kept the paint intact, if covered by experimental coatings. Conservation returned the piece to a condition in which its original artistry could be visible and appreciated and ultimately led to the discovery of the artist responsible for its extensive ornamentation. The *Grace Darling* remains one of very few horse-drawn vehicles in original condition whose artist is known and documented. Countless other examples of the carriage painters’ art have been stripped and sanded from their surfaces. Regardless of how an object is presented, interpreted, or described, its authenticity and physical integrity are what make it a powerful material document and give it the potential to inspire and educate. It is fortunate that an example of the artistry of carriage painting remains to inspire others to a higher regard for original paint and to seek conservation methods rather than restoration as an ethical and desirable way to preserve the historic integrity of horse-drawn vehicles.

---

## Acknowledgments

The author is grateful to the Institute of Museum Services for supporting a part of this conservation project, and to the Early American Industries Association Grants-in-Aid program, which provided funding for the research that identified John Burgum as the artist of *Grace Darling*.

Additional thanks to Linda Merk-Gould, Carol Warner, Deb Brown, Aaron Stoltzfus, and others who worked on this challenging project; and to Lynton Gardiner, whose photographs communicate the artistry of the piece to a larger audience.

---

## Notes

- 1 The author is indebted to Martha Pike for this reference.
- 2 Burgum Family Papers and Abbot-Downing Company Records are on file at Manuscripts Division, New Hampshire Historical Society, Concord, New Hampshire.

---

## References

- Bacon, G. F.  
1890 *The Leading Business Men of Concord*. Boston: Mercantile Publishing.
- Burgum, J.  
1878 Diary entry, 2 October. Manuscripts Division, New Hampshire Historical Society, Concord, New Hampshire.  
1880 Diary entry, 30 June–12 July. Manuscripts Division, New Hampshire Historical Society, Concord.
- Camden, T. E.  
1982 Register including biographical sketch. Burgum Family papers. Manuscripts Division, New Hampshire Historical Society, Concord.
- Dover (Maine) Enquirer*  
1880 29 July, South Berwick, Maine.
- Gipson, R.  
1953a Memorandum to author, Suffolk Museum and Carriage House, Stony Brook, New York, 20 January.  
1953b Memorandum to author, Suffolk Museum and Carriage House, Stony Brook, New York, 9 February.
- Hillick, M. C.  
1906 *Practical Carriage and Wagon Painting*. Chicago: Press of Charles H. Webb.
- Isles, G.  
1963 Correspondence to R. Gipson, 11 September. Suffolk Museum and Carriage House, Stony Brook, New York.
- Memory's Gift*  
N.d. New York: Leavitt and Allen.
- Murphy, C. P.  
1973 Memorandum to Jane des Granges, Suffolk Museum and Carriage House, Stony Brook, New York, 17 July.
- Painter, Gilder, and Varnisher's Companion, The*  
1870 Philadelphia: Henry Carey Baird.

# The Treatment of Painted Wooden Folk Art

*Stephen L. Ray and Julie A. Reilly*

**I**N THE EARLY TWENTIETH CENTURY, the first assemblages of folk art were gathered by collectors who found great aesthetic appeal in the sometimes quaint and often curious expressions of artists who worked outside the mainstream of art. Abby Aldrich Rockefeller was a pioneer in the collecting of American folk art. She began collecting during the 1920s when folk art was mostly ignored by others. In 1935, she loaned a large part of her collection to the Colonial Williamsburg Foundation, and in 1939, this loan became a gift. The Abby Aldrich Rockefeller Folk Art Center (AARFAC) was constructed at Colonial Williamsburg in 1957 by John D. Rockefeller Jr. as a memorial to his wife.

The AARFAC collection contains more than 3,300 objects from the eighteenth, nineteenth, and twentieth centuries and reflects the innate creative skills of many craftspeople and artisans. The collection includes banners, toys, furniture, sculpture, decoys, figures, signs, weather vanes, whirligigs, carousel animals, tools, and advertisements.

In early 1987, the curatorial and administrative staff, in collaboration with Foundation conservators, selected 182 objects to go on a traveling exhibition to nine cities across America. The purpose of the exhibition was to share AARFAC's exceptional collection of American folk art with a broader audience while its building was closed for expansion and renovation. After the chosen objects were surveyed, those requiring treatment prior to travel were sent to the various laboratories in the Department of Conservation. The treatments ranged in complexity from simple superficial cleaning to more complicated structural stabilization and cosmetic reintegration. After the traveling exhibition, these objects were returned to Williamsburg in 1991. Along with 250 additional objects, they were installed in the new wing at AARFAC, which added an additional 1767 m<sup>2</sup> (19,000 sq. ft.) of exhibition and storage space to the museum. This additional group of objects was also surveyed, and conservation treatment was performed on those with the greatest need.

In total, 155 of the objects treated were of painted wood, and the survey and subsequent conservation produced a prodigious amount of documentation. A review of the treatment records made it clear that there were relationships between construction methods and current condition. It is this information that forms the basis for this article.



---

## General Technology and Condition



Figure 1  
*The Race Track Tout*, tobacconist figure, during treatment. H:184.78 cm. This figure had up to four additional layers of paint applied either as routine maintenance or to change its color scheme. Mechanical excavation under the microscope revealed the colors exposed on various parts of the figure (AAREAC, 56.705.3).

---

## Construction Techniques and Condition

Discussions of treatment of folk art frequently begin with a multitude of definitions to convince the reader of its complex and varied nature. Folk art objects *are* complex and varied, and so is their conservation. Bottle caps, house paints, shells, ribbons, discarded bits of tool, and swirls of candle soot are but a few of the materials encountered as components of these objects.

Folk art often displays the creativity of the maker in unique and intriguing decorative schemes—direct outgrowths of the artist’s experience and imagination. This creativity can be expressed in varied imagery with decorative elements often composed of uncommon and inherently short-lived materials, many of which have proved incompatible with the underlying structure or surface finishes. For example, soot or smoke used for decorating surfaces is inherently fragile.

The aesthetic sensibilities of collectors like Mrs. Rockefeller inform our understanding of the objects and the way they appear in collections today. *New, shiny, clean, complete, and smooth* are not words that describe the objects that folk art collectors assembled or expected to see in dealer salesrooms or museum exhibitions. Rather, early collectors preferred objects that were unchanged by restorers or museum professionals, with evidence of use and age being an integral part of the objects’ appearance.

Because it was often functional as well as decorative, folk art usually reflects a repair-and-maintenance history. For example, decoys were repaired and touched up, weather vanes and whirligigs were flattened and repainted, and trade figures were repaired after repeated mistreatment or were repainted in more fashionable colors (Fig. 1). There is a subtle distinction between a *repair* and *ongoing maintenance*. Whether successful or not, both strive to prolong the functional nature of the object, and both usually involve the application of additional materials. Maintenance tends to comprise additions that reflect the history or function of the object over time—additions that may be worthy of preservation. Repairs, by contrast, particularly those made after an object attains “collectible” status, sometimes consist of alterations or additions that not only disturb the appearance of an object but may misrepresent its historical context or function. Examples of maintenance techniques and repairs are discussed on the following pages.

As viewed today in an exhibition, a folk art object represents more than simply an aesthetic creation, the product of the hand and eye of its maker working in a specific time and place. It also represents a collective history of use, beginning with its maker and continuing with its owners and subsequent collectors, dealers, curators, and patrons. The object’s function over time is an integral part of its interpretation and is a feature that is as important to preserve as the object itself.

Although it is risky to attempt to place all folk art into generalized categories, an evaluation of the objects examined revealed four primary means of construction: solid or *log* construction, hollow construction, board construction, and joined construction. Construction types are often mixed within a single object (e.g., a toy may consist of both solid and joined construction). However an object is made, a correlation exists between the construction method and types of damage found on its painted surface. The following paragraphs explain the categories of construction, then address paint-surface problems commonly associated with each type. Paint

problems independent of construction type, such as abrasion from mis-handling, functional damage resulting from the wear of moving parts (e.g., whirligigs, weather vanes, or toys), or inherent deterioration of the paint, are outside the purview of this article.

### Solid or “log” construction

Objects in this category are made from a single, solid block of wood or a solid block composed of several pieces of wood. In the latter case, the techniques for joining the various blocks include dowels, pins, mortise-and-tenon joints, glue joints, nails and screws, and various combinations of these techniques. Examples of objects in this category include decoys, toys, trade figures, and other decorative sculptures.

Damage typically appears in these objects in the form of radial splits and checks. The splits can manifest themselves as barely visible hair-line cracks or as large openings. They may move very subtly with environmental changes (i.e., opening and closing as the wood responds to changes in relative humidity). Similar damage may occur at the interface of joints and laminations, particularly if the grain of one piece of wood is at right angles to another piece. Other damage includes breakage of projecting elements, dents, scrapes and scratches, and worn and abraded surfaces.

Historically, repair and maintenance techniques have varied. Shims were often inserted into large splits, and other filling materials, such as plaster or commercial wood fillers, may have been used. Broken elements were reglued. Nails, screws, and other metal hardware, such as angle irons or “L” brackets, were used as supporting or fastening devices. These traditional repairs generally disguised the symptoms of structural failure without addressing its underlying cause: the inherent instability of wood. As a result, the structural problems encountered in these objects today include not only the initial unstable cracks, but additional shrinkage, splits, and breakage associated with added metal hardware and rigid or unstable shims.

Damage to the paint is most obvious adjacent to splits and cracks, where the film is broken and chipped. However, damage may also appear elsewhere on the surface. This occurs because, in log construction, the paint may be stressed by the extremely uneven dimensional response of the log’s outer surface to fluctuating relative humidities. Around its circumference, the log may experience pronounced dimensional change (tangential shrinking and swelling), while dimensional change will be imperceptible along its length. The paint, on the other hand, experiences a slight dimensional change that is equal in all directions. The differing responses of the two materials place stresses upon the paint, which may cause it to tent, lift, or check across the grain of the wood (see Mecklenburg, Tumosa, and Erhardt herein).

Conservation of these types of objects relies on skills ranging from woodworking to paint consolidation. Treatment may include leaving the object as is; removing old fills, shims, and hardware; or replacing old nails and screws with less invasive materials. Fills can be replaced with more stable, conservation-quality materials (i.e., microcrystalline waxes, bulked epoxies, vinyl spackling compounds, etc.). If necessary, paint surfaces can be consolidated, and losses inpainted.

*The Race Track Tout*, a tobacconist figure (Fig. 2), illustrates damage related to radial cracks, as well as previous repairs. This figure was sent



*Figure 2*  
*The Race Track Tout*, tobacconist figure, before treatment, showing the radial split that ran the entire length of the figure. Remnants of a wooden repair shim remain wedged inside the split. It was uncertain if the shim had ever been glued in place. Paint loss is visible along the edges of the split.

to the Objects Conservation Lab for an investigation of the remains of a wood shim inserted in the back, and for repair of damage to the feet and base. The curators were also interested in what changes had been made to the original paint scheme. With the exception of the arms, the figure had been carved from one "log." A radial split on the back of the figure ran from the top of the hat downward through the head and body and into the crotch. The split appeared again in the base, and another radial split ran at right angles to it. This caused the base to break into four sections and resulted in extensive damage to the feet and ankles. The entire figure rested on an original stand composed of four wide boards nailed together to form a box. As a result of the splits and shrinkage, the figure had collapsed into its stand. Repair attempts had been made using numerous nails. In addition, the proper left arm was broken at the elbow, and it had been reattached using nails and an angle iron fastened with screws.

The treatment of this figure involved removing all nails, screws, and the angle iron, and regluing the separated elements with hot hide glue. Two 6 mm wooden dowels were inserted through existing nail holes in the elbow as additional support in this area. Because large gaps remained in the base, which prevented proper alignment of the four sections, it was reassembled using a carvable epoxy paste to fill gaps and to provide added strength. The original stand was too fragile to support the weight of the figure; therefore, a wooden insert was constructed. The insert, a box, was fitted inside the original stand to hold the figure at the proper height in relation to the sides of the stand. The sides of the stand were tacked to the sides of the insert with a hot-melt adhesive. The split on the back of the figure was filled with a wall of microcrystalline wax (Victory White Wax) approximately 6 mm thick. No attempt was made to fill the entire gap. In addition, all later paint layers were removed. This was accomplished using various solvent systems and mechanical methods.

### **Hollow construction**

Objects in this category are made from blocks and/or boards joined to form a hollow cavity, with a carved outer surface. This method of construction reduces some of the problems noted in log construction. Not only does it reduce the weight of large objects, but hollow construction permits a more even dimensional response of the wood to environmental changes. Splits and separations in the wood tend to be common but are typically narrower than those found in objects made from solid blocks or logs. The techniques for joining the wood components include mortise-and-tenon or lap joints, glue joints, nails, and screws. Characteristic examples in this category are carousel figures.

Structural damage is characterized by separation of the joints, with associated distortion and occasional misalignment of the wooden components. Projecting elements can be loose, detached, or missing, and the high points of the carving may be very worn or abraded.

Traditional repairs on objects of this type of construction include attempts at filling the gaps, adding shims, replacing carved sections, and reworking mortise-and-tenon joints. Nails, screws, and different types of bracing were added to stabilize separations and breaks. Additional glue was applied to old damages, and internal repairs were made. The nature of the structure and attempts at repair affect the condition of the paint. Cracked and lifted paint is often found at the interface of joined pieces

because of differences in the movement of the various components. Paint damage is also commonly caused by poor repair techniques, such as the use of incompatible or rigid gap-fillers or the improper addition of nails, screws, or dowels. Finally, paint loss is associated with the reworking of misaligned components.

Conservation treatment for this type of object may include leaving the object as is, adding fills, removing old fills and replacing them with more stable materials, separating and realigning poorly repaired joints, or removing nonoriginal nails and screws. Paint surfaces may be consolidated and inpainted, with the extent of treatment guided by a sensitivity to the historic use of the object. Since these objects no longer serve the function originally intended, the conservator has the option of making repairs that are not as strong but also not as structurally invasive as earlier repairs may have been.

A carousel figure of a lion illustrates the problems associated with hollow construction. The body and head are hollow, and the legs are carved from solid blocks made from several joined pieces of wood. Join methods include glue and large wood screws. The screw heads were countersunk and covered with wood plugs.

Due to long-term usage, exposure to weather extremes, and repair and maintenance practices, there were numerous separations between the various wood joints, and the legs were loose. Attempts had been made to repair and stabilize the figure with numerous finishing and common nails, and splits and losses were associated with these repairs. Remnants of a filling material were found in some of the gaps and nail holes. Some sections of the wood forming the body had been reshaped to fit the misaligned sections more closely together. Lost portions of the object had been replaced. The front legs, originally extended forward to give the lion a leaping effect, were cut at the knees and reworked to place their upper and lower sections at right angles. This probably was done to reduce the length of the figure to fit in the home of a collector. The painted surface was in an extremely degraded condition, showing evidence of past repainting and stripping of paint using mechanical and chemical means.

Treatment of this figure included removal of all nails and other past repairs and realignment and regluing of the joints. The front legs were disassembled, and new wood added and carved in order to return the legs to a more natural position. Photographic evidence of similar figures was used as the basis for this decision. The painted surface was consolidated using an acrylic resin.

## Board construction

Objects in this category are made from joined boards or planks. Techniques for joining the boards include butt joints, lap or dovetail joints, and metal or wood battens. Nails or screws may also join elements. Examples of objects include trade signs, weather vanes, and decorated storage boxes.

Structural damage includes splits and separations at the joints, cracks at the sites where battens have been attached, and varying degrees of warpage. Scratches and dents are common, as is damage to the corners.

Traditional repairs usually involved methods to secure the boards. Regluing and attaching additional battens or straps on the reverse were common techniques, and fill materials were often added to larger gaps.

These repairs and fills frequently exacerbated problems, restraining the natural movement of the wood and resulting in additional splits, warpage, and paint loss. Additional paint loss may be associated with the species of wood and the manner in which the board was sawn. Plainsawn boards are often found in this type of construction, and a distinct earlywood/latewood pattern may become apparent because of poor paint adhesion to the denser latewood of a species such as yellow pine. Though losses from latewood may be extensive, the paint remaining on the earlywood surface may be very stable because of strong adhesion.

Techniques developed for the treatment of panel paintings sometimes apply to the conservation of folk art objects made of joined boards. Treatment options may include the removal of added restraints; the design of new nonrestraining supports; and the consolidation, filling, and inpainting of paint losses. Provision for maintaining the object in a controlled environment is a highly recommended practice, as it is for all folk art objects.

As an example, the painted Sutton fireboard in the AARFAC collection (AARFAC, 56.110.1) had been constructed from four random-width boards. Two original battens were attached to the back with iron nails, and two thick iron straps were later attached adjacent to each batten with a screw into each board. The restraint placed on the boards by the battens and the added iron straps resulted in extensive splitting along most of the length of the top board. The splits emanated from the screw sites and resulted in paint loss and some planar distortion. In an attempt to relieve some of the restraint, treatment included removal of the iron straps. Where possible, damage was stabilized by injecting hot hide glue into the splits.

### Joined construction

Objects in this category are made from numerous pieces of wood joined in various ways, depending on the function of the object. Such objects include whirligigs, toys, and small sculptural figures. Join techniques include the use of nails, screws, metal plates, and other hardware; glue joints for fixed connections; pins, dowels, mortise-and-tenon or lap joints, et cetera.

Repairs seen on these types of objects include additional nails and/or screws to secure split or separated elements, and replacement of detached and lost components. Past repair attempts may have also rendered the object nonfunctional by restraining its moving parts.

Damage encountered includes loose joints, misaligned and/or missing parts, replacement parts made of incompatible materials, and added fasteners. Paint loss may have occurred at joints and in areas associated with repairs. Mechanical wear from friction of moving elements may have resulted in structural instability. Damage to the paint also occurs at the interface of the joined elements. In those objects where one part rubs against another (as in the case of a whirligig), abrasion to the paint surface is usually encountered. Damage is also found at the site of metal fasteners where star-shaped or circular crackle patterns in the paint define the heads of nails or screws. In some cases, the nail or screwhead has been pushed out of the wood to some extent, with associated loss to the paint layer.

*The Politician* (Fig. 3), a small sculptural figure, is constructed of a number of joined elements. The radiograph (Fig. 4) shows numerous nails, most of which were used to assemble the object. The screws securing the arms at the shoulders, due to their suspected modern manufacture, may be replacements. A merganser decoy (Fig. 5) illustrates how a previ-



*Figure 3*  
*The Politician*, before treatment. H:60.64 cm.  
This small figure is an example of a joined construction object. The buttons, bow tie, and cape are made of painted leather (AARFAC, 63.705.1).

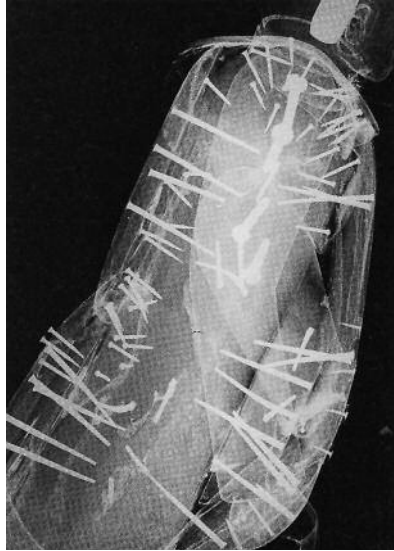

*Figure 4*  
*The Politician*, during treatment. Radiograph illustrating the large number of nails used to fasten the various components. The large white block in the head area is a dowel used to secure the hat to the head.

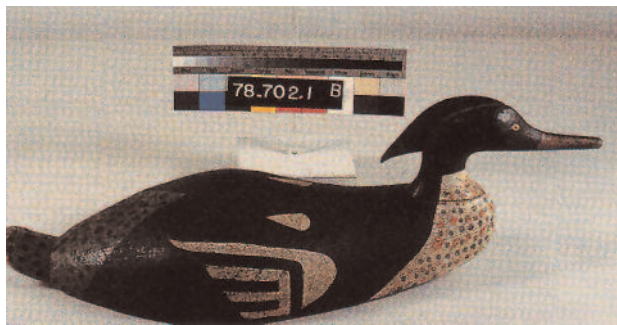

*Figure 5*  
Merganser drake decoy, before treatment. Note the slight misalignment at the interface of the neck and breast (AARFAC, 78.702.1).

ous repair can cause misalignment of joined elements. The normal light photograph shows the slight misalignment at the interface of the neck and breast. A radiograph of this decoy showed that the addition of an internal iron pin and nails held the neck out of alignment with the breast.

Various techniques are utilized for the conservation of these objects. Treatment options may include leaving the object as is, designing and attaching mechanical supports and mounts, or applying additional adhesive to weakened joints. Old repairs or added fasteners may be removed and replaced with more stable materials, although great care must be taken to distinguish original materials from later additions. Protruding nails may be pushed back into place if the condition of the paint allows. Paint surfaces damaged by repairs or later attachments may be consolidated, and losses filled and painted. Areas abraded by the friction of original moving parts, however, are evidence of historic usage and should not be inpainted.

---

## Case History

Given the variety of materials and techniques utilized by folk artists—many of which are fragile and unstable—it is impossible to standardize treatment approaches and materials. Furthermore, the repair and maintenance history of these objects complicates treatments because the preservation of evidence of repair and maintenance is frequently desirable. Thoughtful discussion among curators, owners, and conservators is essential in developing a sensitive treatment plan.



*Figure 6*  
*The Clown*, tobacconist figure, ca. 1860, before treatment. H:187.32 cm. This figure may be a portrait of George L. Fox, who was a clown and an actor. The figure was used to advertise cigars named after George W. Childs, a publisher and philanthropist (AARFAC, 56.705.2).

*The Clown*, a polychromed tobacconist figure (Fig. 6), was carved from a solid piece of eastern white pine. The head was carved separately and inserted into a large recess in the shoulders, and the outer elbows are additional pieces of wood that were laminated to the main “log” of the body. The base, a replacement, is composed of five thick pieces of wood nailed together to form a box approximately 46 cm square. Two 42 cm long iron bolts had been inserted through the underside of the base into holes drilled into each leg, to secure the figure to the base. Nuts were secured to the ends of the bolts through mortises carved into the calf of each leg. The mortises were filled with plugs of wood. Additional support was provided by a tree branch nailed between the rear top edge of the base and the crotch of the figure.

Although the figure was in relatively stable condition, several features caused concern for curatorial and conservation staff. The head portion was loose, and fill material in the base of the neck was insecure and crumbling. The head seemed to be out of proportion to the rest of the figure, and an old repair on the side of the nose was loose. The color and character of the head was also inconsistent with the remainder of the figure. In addition, areas of darkened overpaint up to 7–8 cm in diameter were visible on the higher points of the figure. Both feet were heavily damaged and had been nailed back together; the nails had caused additional splitting of the wood, and the pieces were very poorly aligned.

Further examination revealed two large radial splits, filled with a hard puttylike material, running through the left side of the body from the base of the neck to the crotch. The splits had enlarged the recess in the shoulders, allowing the head to shift position. There was also a radial split on the rear of the head (Fig. 7). This split and a large loss on the top of the head had been filled with the same material that was used at the base of the neck. Through visual inspection, the material appeared to be plaster. Apparently the head became detached at some point, possibly as the result of a forward fall (such a fall could also explain the broken feet and damaged nose). In a poor attempt to repair the damage, the head was improperly reattached in the position seen in Figure 6.

Microscopic examination of the paint layers at the edges of losses and cracks showed the presence of a white ground layer. Above the ground, the legs and portions of the costume were painted red, and then various colored details were added. A clear coating, now very yellowed, had been applied over the paint. Examination revealed that the darkened areas of paint on the high points were areas of retouching applied to camouflage losses and abrasions to the original paint layers. Tests with various solvents showed that the head had been completely overpainted, presumably to hide the fill materials and to brighten the overall appearance. Overpaint matched the color of the original paint as altered by the discolored clear coating (e.g., areas originally painted blue had turned green because of the yellowed varnish; these had simply been overpainted with green).

During treatment to extract the crumbling fill material, the head was removed (Fig. 8). This revealed additional fill material from a past restoration: crumpled brown paper bags and plaster stuffed into the neck cavity. Because the figure had been used outdoors, water had seeped into the cavity and had caused extensive damage to the wood. After a thorough cleaning of the cavity to remove loose debris, the deteriorated wood was



*Figure 7*  
*The Clown*, during treatment. This photograph shows the detached head with a radial split and associated fill material, as well as damage to the neck.

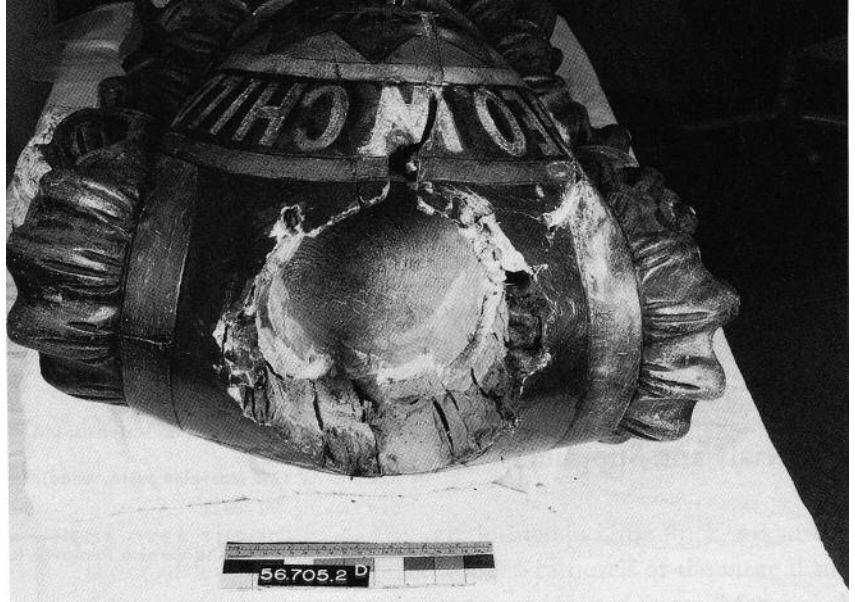

*Figure 8*  
*The Clown*, during treatment, showing fill material and extensive damage to the neck cavity as a result of water infiltration.

consolidated with Acryloid B72, and the head was reattached in its proper position with a carveable epoxy paste (Araldite AV 1253).

To stabilize the figure, it was detached from the base by first removing the tree branch, which was determined to be a twentieth-century addition and inappropriate for current exhibition purposes (it was placed in storage). The wood plugs on the calves were then removed; the bolts were extracted through the underside of the base, and the base removed. The nails that held portions of the feet to the legs were then extracted. The split, misaligned feet were reassembled and adhered with hot hide glue. Two 5.08 cm ( $\frac{1}{2}$  in.) diameter stainless steel pins, 40.6 cm in length, were used to secure the figure to the base instead of the iron bolts. The pins, which had a 10.2 cm square plate welded to one end, were inserted through the bottom of the base, and wood screws were used to fasten the plate to the underside of the top of the base. The figure was then lowered onto the pins, and the wood plugs were adhered in position with hot hide glue.

Solvent tests were conducted to determine the solubility of the paint layers. Based on these tests, the overpaint was removed with acetone or propanol in a methyl cellulose gel and, when necessary, a commercial paint stripper for the more intractable areas. During this process, the discolored coating was also removed. This proved to be an advantage in the cleaning of the head, which retained nearly intact, stable, original paint, with disturbed areas adjacent only to the split and loss. The losses and cracks exposed by removal of the overpaint were filled with Perma-Fill Ready Mixed Spackling Paste. Fills were sealed and isolated with Acryloid B72 and inpainted with Bocour Magna Colors (see list of Materials and Suppliers at the end of this article).

---

## Conclusion

This discussion of construction methods, repair details, maintenance history, and current condition has demonstrated that construction features can be used to loosely categorize painted wooden folk art for the purposes



of understanding current condition and developing potential treatment options. Objects of a particular construction type ("log," hollow, board, or joined) exhibit definite patterns of maintenance practice, repair history, and loss and deterioration, which are evident in both the structural elements and paint surfaces. Although knowledge of these patterns can aid in the evaluation of problems affecting any folk art object, treatment options rarely fall into standardized approaches. Each object, due to its unique material and aesthetic nature, warrants individualized thought and attention from experienced conservators and knowledgeable curators for the formulation of appropriate conservation treatment methods.

---

## Materials and Suppliers

**Acryloid B72**, Conservation Materials, Ltd., 100 Standing Rock Circle, Reno, NV 89511.

**Araldite AV 1253 (carvable paste, wood)**, Ciba-Geigy Corporation, 4917 Dawn Avenue, East Lansing, MI 48823.

**Kwik Marine Paint and Varnish Remover**, Klean-Strip division of W. M. Barr, Inc., Memphis, TN 38101.

**Magna Colors**, Bocour Artist Colors, Inc., Garnersville, NY 10923; distributed by Conservation Materials, Ltd.

**Methyl Cellulose**, Talas, 213 West 35th Street, New York, NY 10001.

**Perma-Fill Ready Mixed Spackling Paste**, Bondfast Company, Bridgewater, NJ 08807; distributed by Conservation Materials, Ltd.

**Victory White Wax**, Conservation Materials, Ltd.

# Jeffrey: Horse of a Different Color

Rick H. Parker and Peter L. Sixbey

**T**HE OVER-THE-JUMPS CAROUSEL, located in Little Rock, Arkansas, is one of fewer than 180 intact wooden carousels of the more than 5,000 carousels that once operated in the United States (Morgan 1994). It is the only surviving example of an undulating-track carousel manufactured by Spillman Engineering Corporation in the 1920s in North Tonawanda, New York. It was a familiar sight on amusement ride circuits, including the Arkansas State Fair. In 1942, the forty hand-carved wooden horses and four chariots found their way to War Memorial Midway in Little Rock, where the carousel continued to operate until 1991 (Anderson and Story 1989). During its forty-nine-year period of operation, up to thirty layers of “park paint” were applied to the carousel animals as part of ongoing maintenance. Recent conservation surveys and treatments indicate that most of the original paint layers remain intact (Parker 1994).

Roads to extinction are often paved with good intentions. Numerous well-intended preservation attempts have compromised the integrity of many wooden carousels; very few retain original painted surfaces beneath restoration colors, and even fewer survive intact with their original surfaces exposed.<sup>1</sup> Indeed, restoration efforts have put existing original paint surfaces and designs on “the endangered list.” Carousels have a long and important tradition in many cultures; we should apply the highest conservation standards to the increasingly rare intact examples of this unique, painted wooden art form.

---

## Carousels: A Brief History

The first visual record of a carousel device appeared in a Byzantine bas-relief fifteen hundred years ago (Fried 1964:13). The word *carousel* is a derivation of *carosello*, a seventeenth-century Italian word meaning “little war,” which described a game that originated in twelfth-century Arabia in which horsemen rode in a circular pattern throwing clay balls filled with scented water at one another. This game of equestrian skill was probably the ancestor of today’s familiar merry-go-round. In the royal courts of France, the carousel evolved into a game in which lance-bearing horsemen riding at full speed attempted to spear gold rings. This variation led to the tradition of “catching the brass ring.” To train for these events, knights mounted crude wooden horses attached by beams to a center pole. Servants or horses provided the turning power (Manns, Shank, and Stevens 1986:9).

Englishman Frederick Savage's adaptation of the steam engine in 1870 to power the machinery that rotated the carousel platform heralded the beginning of the modern merry-go-round (Manns, Shank, and Stevens 1986:11). Savage is also credited with the invention of the overhead cranking device that gave the familiar up-and-down motion to carousel horses known as *gallopers* in England and *jumpers* in America (Fried 1964:33). This improved ride appeared all over Europe.

In America, an advertisement for a wooden horse "circus ride" appeared in a Salem, Massachusetts, newspaper as early as 1800 (Dinger 1983:10). But it was not until 1867, when German immigrant Gustav A. Dentzel opened a cabinetmaking shop at 433 Brown Street in Philadelphia and constructed his first carousel (a simple bench seat, horse-powered machine), that the era of hand-carved carousels really began in the United States (Fried 1964:51–52).

The carousel industry grew in late-nineteenth-century America. Many skilled immigrants, familiar with carousels produced in Europe, settled on America's East Coast and supplied the industry's work force (Manns, Shank, and Stevens 1986:11). As America industrialized, expanded leisure time and disposable income gave workers the means to enjoy these new forms of entertainment. City parks, a manifestation of a developing interest in public recreation, proliferated in the larger urban centers. Transportation companies, motivated by financial self-interest, supported amusement centers at such parks, which were generally located at the end of rail or trolley lines. The amusement centers featured increasingly larger carousels as the parks flourished (Weedon and Ward 1983:70; Manns, Shank, and Stevens 1986:70).

Carousels were not only accessible to large urban centers; the outdoor amusement industry expanded into smaller cities and rural communities as well, with traveling amusement ride circuits, still popular today. Traveling carousels generally suffered more damage than the larger, more ornate stationary versions because of constant assembly, dismantling, travel wear and tear, and less substantial shelters from the weather.

---

## Over-the-Jumps History and Description

Over-the-Jumps was manufactured in North Tonawanda, New York, at Spillman Engineering Corporation (ca. 1924). Sometimes called "Lumber City" or "Carousel Capital of the United States," North Tonawanda was a magnet for woodworkers and carvers (Manns, Shank, and Stevens 1986:175; Fried 1964:121). Spillman Engineering was one incarnation of a dynasty of four closely related carousel manufacturing companies, the others being Armitage-Herschell, Herschell-Spillman, and the Allan Herschell Company. These four companies spanned the years from 1890 to 1955 (Table 1). During the "golden age of carousels" (ca. 1905–25), the Herschell companies (including Spillman Engineering) produced more carousels than any other firm in the United States and played a major role in the development of the simpler, smaller, and more mobile traveling, or "county fair," carousels.

An early Spillman Engineering Corporation sales catalogue (1924) described Over-the-Jumps (Fig. 1) as

a circular track  $\frac{1}{2} \times 4 \times 4$  [1.27 × 10.16 × 10.16 cm] angle iron mounted on adjustable jack stands made of 2 inch [5.08 cm] black pipe with quick locking attachments to receive the track. There are 24 sweep arms connected to a

Table 1 History of the carousel in the United States and the Herschell factories

1800	Advertisement for a wooden horse “circus ride” in Salem, Massachusetts
1867	Gustav A. Dentzel constructs his first carousel
1870	Frederick Savage adapts steam engine to power carousels in England
1873	Allan Herschell/James Armitage form Tonawanda Engine and Machine Company
1890	Tonawanda Engine and Machine reorganized as Armitage-Herschell Company
1903	Allan Herschell/Edward Spillman buy out Armitage-Herschell and form Herschell/Spillman Company—largest manufacturer of carousels
1915	Allan Herschell establishes Allan Herschell Company
1920	Herschell/Spillman reorganized as Spillman Engineering Corporation
1924	Over-the-Jumps manufactured by Spillman Engineering (ca. 1924)
1905–25	Golden age of the carousel in the United States
1945	Spillman Engineering Corporation bought out by Allan Herschell Company
1955	Allan Herschell Company goes out of business

Figure 1

According to the company’s sales catalogue, “The track has several dips and hills, leaving the participants riding the device in a perplexed state.”

Figure 2

In the latter days of the carousel’s operation in War Memorial Park, in Little Rock, Arkansas, the twenty-four wooden spoke wheels were frequently soaked with water to expand the wooden components in order to help secure the cast-iron rims.

ballbearing center; on the other end a series of 24 special built wooden wheels with  $\frac{3}{8}$  inch [0.95 cm] steel tires, and equipped with Timken roller bearings.

The diameter of Over-the-Jumps is 12.2 m (40 ft.) with a center pole. According to the sales catalogue, “space required is 56 feet [17 m], 4 to 5 hours time for erecting; [and] for space on a show train, it can be carried on three 18-foot [5.49 m] wagons.” The stationary walking platforms surround the mobile riding platform, and both are constructed of wood planks. The riding platform is sectioned into 1.5 m (5 ft.) segments (twenty-four in all), with one wooden wheel between each segment (twenty-four wheels) (Fig. 2). Each wheel between the segments is approximately 61 cm (24 in.) in diameter, with thick wooden spokes, a cast-iron

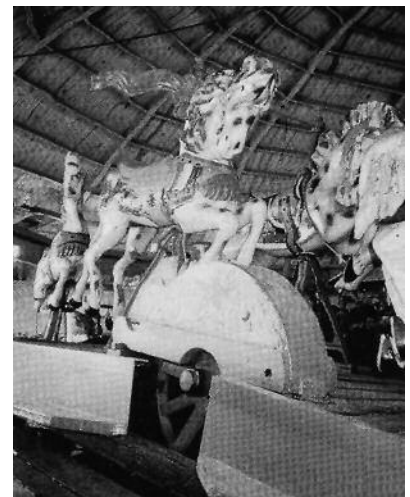

hub and a cast-iron rim. Each wheel is covered with a wood well above the riding platform “to protect the ladies’ dresses from any grease that is frequently collected by wheels from the track.” Each segment carries two horses or one chariot, with one chariot occurring between each set of ten horses. Beneath the riding platform is a cast-iron undulating track, along which the wheels of the riding platform move the horses in an up-and-down galloping motion. Horses are mounted on the riding platform with triangular stands. For power, the carousel requires a 10-horsepower electric or gasoline motor. The sales catalogue describes a “4 cylinder, one piece removable ‘L’ head heavy clutch tractor type motor,  $3\frac{1}{4} \times 5$ . It is equipped with an American Bosch magneto, Zenith carburetor, duplex governor and Oakes ballbearing fan.” The earning capacity of Over-the-Jumps was \$220 per hour (Spillman Engineering Corporation 1924).

Over-the-Jumps made its initial appearance at the Aurora Exposition and Fair in Aurora, Illinois, on the C. A. Worthem World’s Best Shows, 15 August 1924. It is probable that no more than five Over-the-Jumps machines were produced. References have been found to as many as four to five companies that owned a machine: C. A. Worthem World’s Best Shows; Rubin and Cherry Shows (Fig. 3); J. J. Jones Exposition; Royal American Shows; and possibly Siebrand Brothers (Dahlinger 1994).

The traveling circuit of amusement rides that brought Over-the-Jumps to Little Rock remains unknown. Nonetheless, the carousel found a permanent home in the city’s War Memorial Park in 1942, under a domed wood-frame structure that helped protect it from the elements. It operated until 1991, when it was dismantled for restoration. In 1989, the carousel was placed on the National Register of Historic Places by former Governor Bill Clinton. In 1991, a nonprofit organization, Friends of the Carousel, formed to purchase the historic carousel and return it to operation after learning that, despite its listing on the National Register of Historic Places (Anderson and Story 1989), the carousel was in danger of being sold to out-of-state interests.

*Figure 3*  
An Over-the-Jumps carousel as it appeared in a Rubin and Cherry Show in the mid-1920s.



---

## Wood-Carvers, Painters, and Horses

Most of the forty vertical jumping horses on Over-the-Jumps are typical of those produced by Spillman Engineering Corporation in the 1920s. The horses were generally more elaborate than their predecessors; jewels were added and intricate relief carvings appeared with more frequency on the trappings (Dinger 1983:90). Identifiable features of Spillman horses (from 1920 to 1945) include long heads; small, high-set eyes; pointed rumps; full, wavy manes; intricate ornamentation; high cantles and pommels; large nostrils; jewels; and figures in relief. The *romance* sides of the horses (the sides facing outward) were elaborately carved, in contrast to the inward-facing, less-detailed surfaces, which were limited to mostly painted decoration.

The following is a description (Fried 1964:121) of the Spillman Engineering Corporation carving shop:

The carving shop is just above the carpenters shop. Bodies, legs, heads, and tails of the different animals are piled about in orderly profusion; also parts of chariots, shields and cornices all of which are handcarved and very beautiful. One of my first impressions of detail was the discovery that each foot of the marvelously natured little horses was shod with a real horseshoe.

The Herschell companies, including Spillman Engineering Corporation, used basswood for most of the construction, although some animals were made with poplar. The wood was planed smooth and glued up into boxes in a technique referred to as *coffin construction* (Schroeder 1980). A standard animal consisted of six to seven boxes, with a box serving for each major body part: the body, head, each leg, and possibly the tail (some animals had realistic tails made from horsehair). This type of construction allowed the wood to expand and contract with minimal splitting. Coffin construction also reduced the weight of animals, thus simplifying the transport and assembly of traveling carousels.

After assembly, each box was *roughed out* to approximate the form of the body part. Master sketches of each animal being carved were kept on the walls of the factory. Each animal was drawn life-size, and the drawings often included side, front, and rear views to help the carvers establish dimensionality (Brick 1994).

The factory carvers were divided into three distinct groups: apprentices, journeymen, and master carvers. The apprentices, many of whom began learning their craft as early as age five, worked almost exclusively on the legs, a fairly simple and undetailed part of the body. Journeymen worked on the bodies, carving the shoulders and saddles and simpler decorative elements. Master carvers modeled the heads and fine details, oversaw the finishing process of the entire animal, and effected a transition between the work of various carvers once the components were assembled into the complete animal (Fralely 1983:13). The style of the simpler “county fair animals” associated with traveling carousels was influenced by the need for ease of packing, portability, and large-scale production.

Production was greatly increased with the introduction of a duplicating process that used a pantographic cutting apparatus, which allowed one wood-carver to turn out vast amounts of woodwork in a year. In North Tonawanda, the carving machine, which could rough out four bodies at once, was first used in 1913 (Fried 1964:119). After figures came off

the machine, skilled artisans completed the work by chiseling out details and hand carving important features.

The animals were then taken to the paint shop, where various painting, japanning, and gilding techniques and materials were used. The animals generally received a protective coating of shellac after painting (Brick 1994). Very little information exists on the various color schemes and decorations that were used, since few records remain today.

The work of carousel carvers and painters represents a most important phase of American wood carving and painting, although historians have generally failed to document it or acknowledge it as a contribution to American art. Unfortunately, much information about carousel artists has been lost; company books were not always kept and records that once existed have been destroyed or lost in fires or reorganizations. Many of the artists were known only by their first names, and very few signed their work (Fried 1964:117).

Carousels have been categorized as both folk art and fine art, and arguments have been made on both sides of the issue. Fried (1964:118) states:

The term "primitive" is generally used to designate unschooled, crude, naive, or unsophisticated art. Most of our carousel carvers were unschooled in sculpture, naive and unsophisticated in their art understanding, but it can hardly be said that theirs was a "primitive art" nor because of its large commercial use, can their art be termed "folk art." Nor were there any signs of crudeness in the products of the carousel manufacturers after the 1900s.

Carousel historian Tobin Fraley, in *The Great American Carousel* (1994a:70), echoes this notion of the carousel craftsperson as artist:

Although the basic motivation to produce carousels may have been the need to make a living, the drive to create, for these craftsmen, must have gone well past the bounds of just making money. There is no doubt that the sculpting of wooden figures represented an expression of the maker as an artist. The exacting detail, the sweeping flamboyance and the serious grace and beauty of many of the figures created by these men reveal an ambition beyond the creation of a seat on an amusement park ride.

An example in *Over-the-Jumps* is the painstaking effort taken to create details such as dappling and other hand-painted decoration.

Many wood-carvers employed by America's industry were, in fact, very sophisticated not only in technical ability but in their understanding of design and art in general. Most received training through intensive apprenticeships beginning at an early age, and some enrolled in art classes to enhance their careers. Carousel artists recognized for their exquisite designs and detailed carvings include Salvatore Cernigliaro, M. C. Illions, John Zalar, Daniel Muller, Harry Goldstein, Soloman Stein, Charles Carmel, Frank Carretta, Charles Leopold, Eugene Drisco, and many others whose names are now lost but whose work remains as a testament to their outstanding technical and artistic abilities (Fraley 1994b).

As with any other art form, no single label accurately describes or defines carousel art. The degree of artistic sensibility in carousel figures ranges from the very naive to the highly sophisticated. Nonetheless, museums have generally relegated carousel figures to folk art galleries and have failed to adequately exalt the finer examples of carousel art. This charac-

terization of the carousel as “folk” art has influenced the approaches used in past preservation attempts. Current debates about the position of carousel art within the spectrum of artistic expression will undoubtedly impact future conservation efforts.

---

## Past Restorations

Past restoration efforts have greatly compromised the integrity of numerous wooden carousels and carousel figures, in many cases resulting in the complete destruction of original painted surface coatings and decoration. Because carousels were built to turn a profit, repairs to the figures were generally executed as quickly and cheaply as possible. Nonetheless, well into the 1940s, a high level of restoration work was often performed by the same highly skilled artisans who constructed and painted the wooden figures. As this generation of artisans passed away, the quality of carousel restoration declined.

At the advent of a carousel revival in the United States during the 1960s and early 1970s, original paint was disregarded, and stripping, sand-blasting, and hot-bath dipping (which often separated glue joints) were standard restoration methods. In the late 1970s, commercial strippers and cold-bath dipping were commonly used, and the carousel figures continued to be stripped to bare wood. Common repair materials included polyester resin (auto body fillers), epoxy adhesives and fillers, and automotive paints.

An oil-based enamel paint (referred to as “park paint”) was applied in-house to carousel figures as an ongoing maintenance procedure for operating carousels. It was a cheaper option than contracting with carousel companies for repainting (Walker n.d.). Paint analysis on the Over-the-Jump horses indicates that up to thirty layers of paint were applied over the years. Park paint was generally applied by relatively unskilled workers who had neither the time, desire, nor talent to duplicate original colors and painting techniques. Consequently, the original artists’ intentions were completely obscured. These heavy, multiple layers of visually unimpressive park paint have, however, provided the protection necessary to preserve the original paint layers.

Standards for fine arts conservation have rarely been applied to carousel preservation. When Friends of the Carousel, the organization formed to save Over-the-Jumps, contacted well-known U.S. carousel restoration companies and requested restoration proposals and cost estimates, no company submitted a proposal that included preservation of the original paint. A standard procedure appears to be the documentation of original colors and designs, stripping the figures to bare wood, and complete repainting.

Recently, some restorers have used a more sensitive approach, in which windows are opened in various areas of the figures, original colors and designs are documented, and the figures are repainted in the original colors and design over a stable layer of park paint. This method retains the original paint beneath the protective layers of park paint (Ragan 1988:31–32).

The conservation of culturally important objects such as Over-the-Jumps, which by tradition or necessity exist as functioning artifacts outside a proper museum environment, presents formidable challenges. In 1992, a general conservation survey of the forty carousel horses of Over-the-Jumps was conducted by Parker Restoration and Conservation Services, who then carried out treatment of “Jeffrey,” one of the forty



Figure 4  
Jeffrey, before treatment.



horses on the carousel (Fig. 4).<sup>2</sup> Though the carousel project has only begun, the initial efforts on Jeffrey have already provided a wealth of information. Future study and conservation of this increasingly rare object—an intact wooden carousel—promise to fill many of the gaps in our knowledge of original carousel colors and design schemes, as well as the painting techniques and materials used in the 1920s by Spillman Engineering Corporation on this most impressive artifact, Over-the-Jumps, the Arkansas carousel.

---

## The Treatment

In 1992, the Friends of the Carousel contracted Parker Restoration and Conservation Services to examine Over-the-Jumps for evidence of original factory paint schemes. Proposals already received from carousel restoration firms recommended the removal of paint to the bare wood prior to repainting, so the Friends wished to document the original scheme while it was still possible to do so. If early colors were found, the information could improve the accuracy of the replication.

A cursory examination revealed many layers of park paint covering the horses, but very little serious structural damage. The paint layers were in poor condition and were covered with a thick, clear coating, possibly polyurethane varnish. When applied, this coating had penetrated fissures in the paint on each horse, allowing solvent to reach an early varnish layer and cause it to swell. This produced considerable disruption in the upper paint layers and resulted in islands of separated paint. Flaking, tenting, and crazing paint; abrasions; and paint loss were common problems on most of the horses.

Despite these problems, the condition of the horses looked very promising. Several were randomly chosen for elementary tests, and a basic examination was undertaken to search for early decoration beneath the park paint. Solvent action was relatively unsuccessful in removing upper layers, but dry scraping with a surgeon's scalpel seemed successful in revealing the earliest coatings. Because it seemed possible to recover much of the factory paint scheme, the board of directors of the Friends of the Carousel agreed to deliver one of the horses to the laboratory for further

exploration. After a review of the condition reports, Jeffrey, a horse exhibiting a range of the surface problems encountered on all of the horses, was chosen as the best example for study.

The horse arrived at the laboratory in the spring of 1993. Upon arrival, six representative cross sections were taken from various portions of the horse. Up to thirty layers of paint and varnish were present in some areas, while as few as fourteen were found in areas of wear. Visible light microscopy and ultraviolet light microscopy, with the use of stains,<sup>3</sup> indicated that the paint layers were all lead-based, oil-bound paints. Solvent tests demonstrated that all of the paint binders had similar solubility parameters. The samples revealed the original coatings in the following order: first, several layers of lead white primer were applied to the wood; a paint layer, believed to be the original factory paint, lay directly over the primer in each sample; over the paint layer was a heavy varnish coating, which appeared to consist of several thin coats of similar solubility, since each successive layer had coalesced with the previous one.

With as many as thirty coats of paint visible in the samples, a brilliant array of color emerged beneath the microscope, yet the recovery of the factory paint remained the absorbing task. Solvents proved to be unsafe; while effective in swelling the upper layers, they penetrated the cracks between the islands of paint and swelled the early layers at the same time. Several promising solvents were gelled in an attempt to control their activity, but this also proved unsatisfactory. Several scraping techniques were tried, but the paint was too thick and extremely brittle, and the techniques were too time-consuming, considering the limited budget for the project.

However, the scraping trials confirmed that sound, intact early layers existed, and revealed interesting information about the factory paint scheme. Prior to examination, one authority suggested that only the more visible, outward-facing sides of the horses would exhibit elaborate decoration, but this proved false. While the outer side certainly displayed more jewels and other carving, the inner side bore intricate painted trim and detail executed in small, deft brushstrokes. Small painted elements emerged all over the horse—pinstripes, painted patterns, and realistic dappling. The placement of the final detailing was surprising; areas expected to show decoration were sometimes plain, while areas assumed to be undecorated often contained fine ornament.

The scraping worked well in some areas, revealing interesting undocumented details at every test site. As work progressed, however, it became apparent that past exposure to water in some areas had made the primer layer very fragile and subject to damage; therefore, scraping was halted, and the primer consolidated where necessary using rabbit-skin glue.

So far, all trial techniques showed some success, but none proved efficient and consistently effective. An attempt was then made to locate someone who had dealt with a similar problem. Most literature regarding previous carousel restorations reflected the standard commercial approach—a cold-tank immersion to “get rid of the old paint,” thereby producing a stable ground for repainting in appropriate colors. As this was an unacceptable alternative, several objects conservators were consulted for more sensitive methods of dealing with the numerous paint layers. Although some techniques worked, none proved suitably efficient for the treatment of forty horses.

As a workable plan had yet to be achieved, the cross sections were reexamined in a search for other possible approaches, and several more samples were taken to aid in the study. When cross-section photographs were compared, the thick varnish over the factory paint stood out in each sample (Fig. 5). If this layer of varnish could somehow be manipulated, the factory paint could be preserved.

The scraping had produced one helpful clue. The thick coating of varnish was very soft, while the layers of overpaint tended to be extremely brittle. From looking at the cross sections, it seemed likely that heat applied to the surface would further soften the varnish, allowing it to be manipulated beneath the overpaint. Areas 7.6 cm (3 in.) square were masked off with blotting paper, and a heat lamp was aimed at the exposed surface. Using a scalpel, it was possible to work into the softened varnish layer and lift all of the overpaint at one time.

Feelings of elation were premature, however, as concerns arose about the absorption of heat by the original paint, as well as by the wooden body of the horse. A hot-air gun, selected as a more controllable heat source, worked somewhat better but was cumbersome. It was difficult to use the heat gun, put it down, pick up a scalpel, and work the island of paint free. This process produced an extremely brief window of time in which to manipulate the softened varnish, and as a result there was a tendency to apply too much heat to increase the working time. The next attempt, using a commercial hair dryer, worked fairly well, but prolonged heat exposure was still an issue.

At this point, Robert Pennick, a colleague with considerable experience in commercial paint removal, was consulted. A period of brainstorming produced a successful two-person technique: one person handled a heat gun, while the other used a scalpel to lift the islands of paint. At first, this process varied in success, but it soon developed into a comfortable rhythm and gave very acceptable results. Surface temperature was controlled by varying both the distance of the gun from the horse and the duration of exposure. The heat gun operated at a lower temperature than the heat lamp, yet it warmed a larger area. Very little heat was required to remove the upper layers of paint from the thick varnish. When an island of paint began to move but resisted lifting, the heat was decreased just enough to keep the varnish warm (about the consistency of thick molasses). This permitted the removal of small sections of the paint with either forceps or the scalpel.

*Figure 5*  
Photomicrograph from the saddle blanket of Jeffrey, showing the thick varnish layer over the original factory paint (yellow coating over the lead white primer layer).

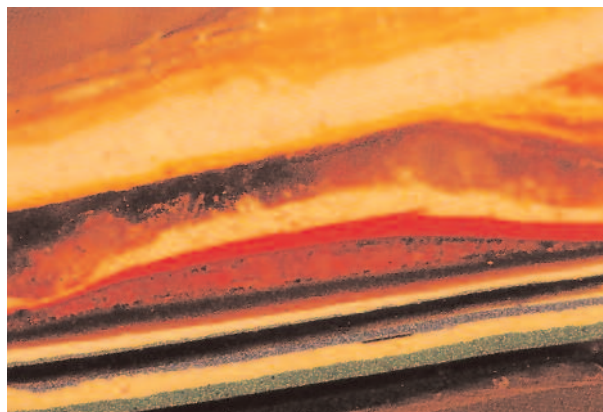

Because of wear, areas such as the saddle and knees had little or no varnish, and the later paint lay directly above the factory coatings in these areas. They were carefully scraped at room temperature because the heat required to move the upper layers would also damage the original paint. Although there was considerable wear to paint in the saddle area, the color scheme remained clearly visible.

An object is usually repainted for a reason. As the overpaint was removed, additional wear was evident on Jeffrey. Though in good condition considering this horse's hard life, the factory coating on the flanks of the animal was worn by the mounting and dismounting of countless riders. Improper storage and handling also had caused considerable damage, and the legs were damaged at points where they bore the weight of the horse in storage. The horse had also been stored on its sides, resulting in numerous abrasions. There was evidence of water damage and exposure to the elements.

It is interesting to note that the first overpaint on top of the factory decoration was a very good reproduction of the original. Great pains had been taken to replicate not only the color scheme but the articulated brushstrokes; the stippled pattern of the horse's coat was expertly handled. Each successive coating, however, received less attention and appeared more sloppy, culminating in the final coating, where a spray can was used to shade the knees, tail, and mane.

The heat gun/scalpel process worked extremely well and was economically comparable to the "dip, strip, and total repaint" method mentioned earlier. Control of the heat gun permitted the execution of very delicate work. Often considered a rather brutal and crude tool, the heat gun produced remarkable results in the removal of overpaint from Jeffrey, and it suggested interesting possibilities for future applications.

After removal of the paint, considerable dark, thick varnish still remained on the horse. A series of solvent mixtures with acetone, devised using a Teas diagram, was used to clear the varnish. While the varnish was easily cleaned from the body of the horse, several underlying painted elements (including the orange saddle trim, the dark green saddle blanket, and the orange breast trim) were also easily lifted by this solution. A mixture with less acetone was devised to clear the varnish residue from these areas.<sup>4</sup>

By this point in the process, the treatment deviated considerably from the initial objective: finding the factory paint scheme prior to repainting. In the beginning, there was little to indicate that intact paint schemes might be found. Now, although the recovered surface coating was by no means in pristine condition, it was apparent that the original painted decoration, complete with previously undocumented details, could be saved. A conjectural replication was unnecessary.

One of the early stated goals of the Friends of the Carousel was to return the carousel to operation. Presented with new possibilities for treatment of the horses, there were now mixed feelings by the board members as to what should be done. All realized that subjecting Jeffrey to the normal wear and tear of a functional carousel would jeopardize the survival of his fragile, newly revealed original painted decoration. The entire board made the journey to the laboratory to view the horse prior to any filling or inpainting. Some felt the horses should remain untouched, to be displayed in "as is" condition, while others felt strongly that the public supporting the project would not properly understand the horses if

damage were allowed to remain visible, that filling and inpainting should be done to make a better public presentation. Above all, there was the aforementioned concern that these original surfaces would be damaged if the carousel was returned to operational status.

The ultimate fate of the carousel now hinges upon the resolution of a dilemma; the desire to use and enjoy Over-the-Jumps as a functional carousel conflicts with the desire to preserve it as a historic and artistic work. One of the charms of the carousel is that it is a one-of-a-kind ride; an integral part of the experience is the ride itself. While some on the Friends of the Carousel Board would like to see the horses displayed as objects of art, others propose treating the carousel in a manner similar to a historic home: permitting limited use with the expectation of some wear and tear. If this plan is adopted, the horses will require a protective coating that is durable in order to withstand use by the public, clear so that the colors are visible, and reversible (to meet conservation standards). Even so, a coating alone will not prevent damage if the carousel is returned to operation. Clearly, the dilemma of usage versus preservation requires careful deliberation by the board of directors.

As a result of the laboratory visit, the board authorized limited filling and inpainting of areas on Jeffrey where significant, visually distracting damage had occurred. Acrylic gesso, smoothed with xylene, was used to level the major areas of loss, resulting in an immediate visual improvement to the horse. Dammar varnish was applied to saturate the colors before inpainting. On the sides of the saddle (Fig. 6)—which was previously considered too damaged for anything but repainting—a very faint shadow of a painted pattern simulating tooled leather was barely visible. This saddle area was given a barrier coating of poly(vinyl acetate) (PVA AYAF) in methyl alcohol and left as is for the time being.

Other than the saddle, roughly 85% of the horse retained original paint. The original artist obviously had a highly developed color sense, producing a diversity of colors by intermixing a limited palette of pigments. For example, the saddle brown is a mixture of dark green (phthalocyanine green) and cadmium orange. The dapple, which closely approximates hair, is a dry-brush, stippled technique that has a far different character than the airbrushed dapple used on many newly restored carousel horses. The paint scheme was very carefully planned and executed, reflecting a skillful artist's knowledge of colors and mixing.

*Figure 6*  
Photomicrograph from the saddle area, showing the lack of heavy varnish over the original factory paint (brownish yellow over the lead white primer) and the convoluted paint layers above it.

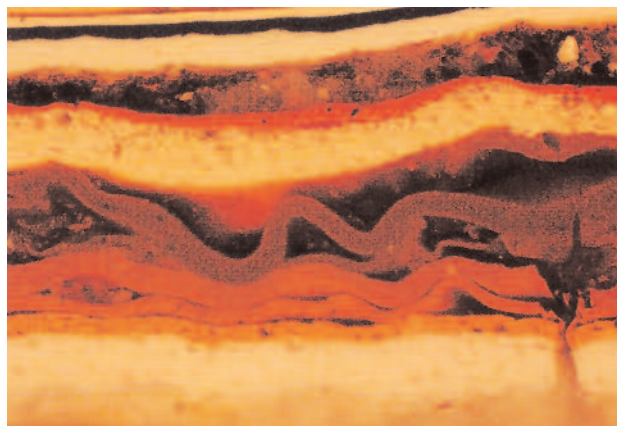

Inpainting of Jeffrey was done with an Acryloid B72/xylene mixture and Maimeri Colors (with the exception of the phthalo cyanine green, which was a Magna Color, used because it produced a closer color match).<sup>5</sup>

After most damaged areas of the horse were inpainted, the saddle received further attention. The shadow pattern of the tooled design was inpainted to enhance the definition of the overall pattern. Because of the extent of damage on the outer portion of the horse, however, the inpainting in this area is somewhat conjectural. As more horses are treated, the complete pattern may appear elsewhere, allowing exact replication in a future treatment. Of significance is the fact that this simulated tooling is not documented in any of the literature researched thus far. If these horses had been cold-tank stripped, patterns such as these would have been lost forever.

After the inpainting was done, a protective coating of orange shellac was applied over the entire surface to simulate the amber appearance of the factory varnish. This is by no means a final varnish, but a proper formulation has not been decided upon at this time.

As a result of the work on Jeffrey (Fig. 7), treatment of a second horse, "Swift," has begun. The work done on Jeffrey has been fruitful, as the conclusions drawn from the initial treatment apply equally to the second horse, and therefore treatment of the outward-facing surface of Swift proceeded quickly. On the inward-facing surface, however, the heat/scalpel process proved ineffective, probably because the horse had lain in water, which seriously damaged that side. Heat, even used minimally, was too damaging to the original layers; consequently, the entire side had to be carefully scraped with a scalpel to remove the upper coatings.

Figure 7  
Jeffrey, after treatment.



The knowledge gained from the work on Jeffrey will aid in the formulation of future treatments for Over-the-Jumps horses. Each horse will be examined microscopically to discover pertinent problems and to determine the color scheme prior to treatment. The second and third horses already exhibit hidden art comparable to that on Jeffrey, and there is reason to expect the emergence of additional remarkable ghosts from the past as the project progresses. Meanwhile, plans for a long-term home for Over-the-Jumps are being prepared by the internationally known architect E. Fay Jones of Fayetteville, Arkansas. The pavilion, to be located on the grounds of the Little Rock Zoo, will be a work of art designed to complement the treasures it will house.

---

## Notes

- 1 In the United States, the best example of a carousel with its original decoration intact is Philadelphia Toboggan Company no. 6 in Burlington, Colorado. See Morton (n.d.).
- 2 As part of a fund-raising campaign established by Friends of the Carousel, "Jeffrey" was named by his "adoptive pony parents."
- 3 All samples were taken by scalpel and mounted in Extec clear polyester resin. The samples were polished using successive grades of Micro-mesh abrasive from 60 to 12,000 grit. Samples were viewed with a Nikon Alphaphot 2 ultraviolet light microscope. The stains used were triphenyltetrazolium chloride (TTC) to identify carbohydrates; fluorescein isothiocyanate (FITC) to identify proteins; Rhodamine B (RHOB) to identify lipids; tetramethyl Rhodamine isothiocyanate (TRITC)—Texas Red—to identify proteins; and antimony pentachloride (APC) to identify natural plant resins (see Materials and Suppliers).

- 4 For the Teas diagram, see *Predicting Resin Solubility* (1984), a technical bulletin available from Ashland Chemical Company, P.O. Box 2219, Columbus, Ohio.

Acetone	45%	Acetone	50%
Diacetone alcohol	25%	Toluene	50%
Mineral spirits	30%		

Acetone	30%
Diacetone alcohol	30%
Mineral spirits	40%

- 5 PVA AYAF, Acryloid B72, and Maimeri Colors are still available; however, the Magna Colors have been discontinued.

---

## Materials and Suppliers

**Acryloid B72**, Conservation Materials, Ltd., 100 Standing Rock Circle, Reno, NV 89511.

**Extec**, Excel Technologies, 99 Phoenix Avenue, Enfield, CT 06082.

**FITC, RHOB, TRITC, TTC**, Sigma Chemical, Box 14508, St. Louis, MO 63178.

**Maimeri Colors**, Conservation Materials, Ltd.

**Micro-mesh abrasive**, Micro-Surface Finishing Products, Box 818, Wilton, IA 52778.

**PVA AYAF**, Conservation Materials, Ltd.

---

## References

- Anderson, M., and K. Story  
1989 National Register of Historic Places nomination, Over-the-Jumps. Arkansas Historic Preservation Program, Little Rock, Ark.

- 1994 **Brick, E.**  
Telephone conversation with the author.
- 1994 **Dahlinger, F.**  
Telephone conversation with the author.
- 1983 **Dinger, C.**  
*Art of the Carousel*. Green Village, N.J.: Carousel Art.
- 1983 **Fraley, T.**  
*The Carousel Animal*. Berkeley, Calif.: Zephyr Press.
- 1994a **Fried, F.**  
*The Great American Carousel, A Century of Master Craftsmanship*. San Francisco: Chronicle Books.
- 1994b History of restoration techniques. National Carousel Association Technical Assistance Conference. Meridian, Miss.
- 1964 **Fried, F.**  
*A Pictorial History of the Carousel*. Vestal, N.Y.: Vestal Press.
- 1986 **Manns, W., P. Shank, and M. Stevens**  
*Painted Ponies, American Carousel Art*. Millwood, N.Y.: Zon International Publishing.
- 1994 **Morgan, B.**  
Telephone conversation with the author.
- n.d. **Morton, W.**  
The restoration of Philadelphia Toboggan Company #6. In *Carousel Manual*, vol. 1, 9–16. N.p.: National Carousel Association.
- 1994 **Parker, R.**  
Conservation condition/treatment report, Over-the-Jumps carousel figures. Parker Restoration/Conservation Services, Gentry, Ark.
- 1984 **Predicting Resin Solubility**  
Columbus, Ohio: Ashland Chemical.
- 1988 **Ragan, R.**  
Saving original paint on carousel animals and pieces. *Merry-Go-Roundup* (winter).
- 1980 **Schroeder, R.**  
The carousel horse. *Fine Woodworking* 23(July/August):62–64.
- 1924 **Spillman Engineering Corporation**  
Over-the-Jumps sales catalogue A. North Tonawanda, N.Y.: Spillman Engineering Corporation.
- n.d. **Walker, C.**  
*Preservation of Park-Paint*. Technical leaflet. Atlanta: National Carousel Association.
- 1983 **Weedon, G., and R. Ward**  
*Fairground Art*. New York: Abbeville Press.



PART FIVE

# Ethical Considerations

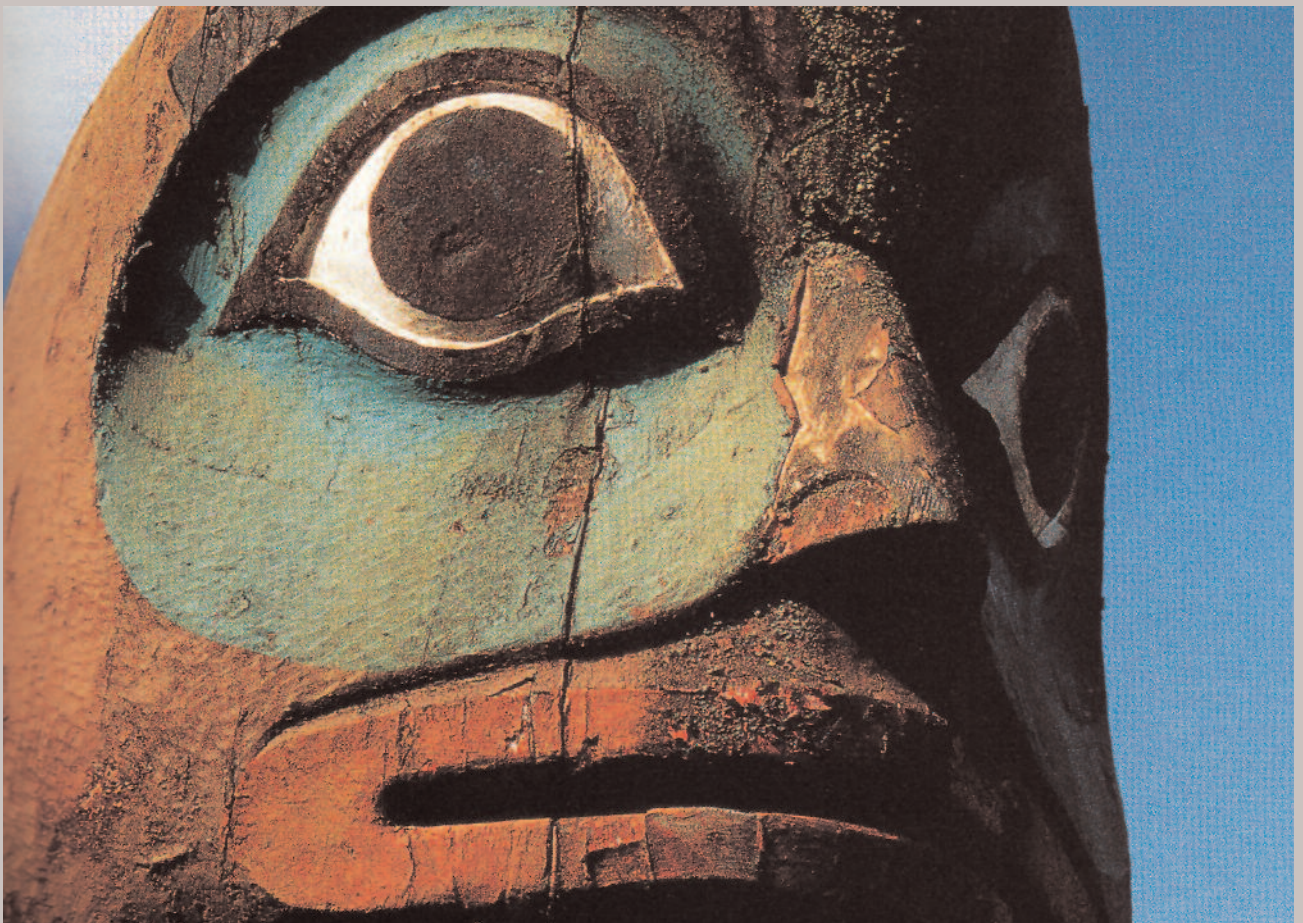

# Painted Memory, Painted Totems

Andrew Todd

**T**OTEM POLES of the Pacific Northwest are unique, monumental carved wooden sculptures—the most outstanding evidence of the sophisticated, dynamic people who inhabit the coastal regions from northern Washington State, through British Columbia, to southeast Alaska (Fig. 1). The carving and raising of totem poles has taken place for at least two hundred years, and possibly over five hundred. The origin of

Figure 1  
Map of Northwest Coast: northern Washington State; British Columbia, Canada; and southeast Alaska.

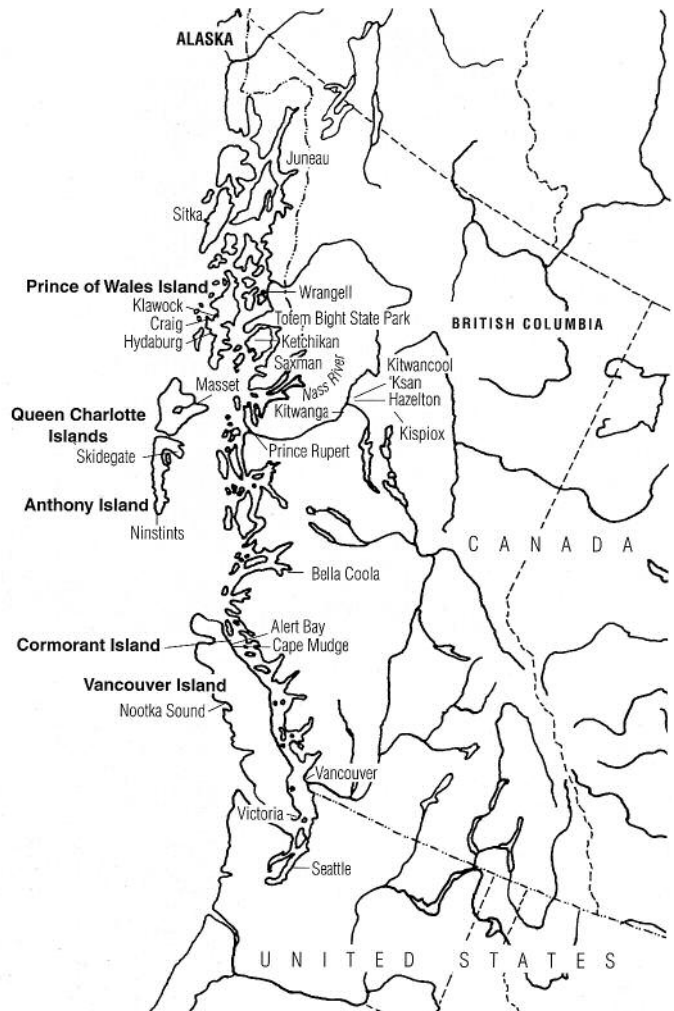

Figure 2  
Detail of Raven Pole 6, Klawock, Alaska. The poor condition of paint is recorded in an examination report of 8 July 1994. This condition reflects the overall state of preservation at the Totem Park in Klawock, Alaska.



their history as wooden objects is obscure; even the rot-resistant western redcedar, commonly used for totem poles, deteriorates rapidly in the relatively warm, moist climate. However, archaeological evidence indicates that the indigenous people of the Pacific Northwest were felling and splitting trees into planks with sophisticated tools and techniques hundreds of years before the arrival of the Russian, Spanish, or British explorers.

Only a finite number of historic totem poles remains. In the village of Hydaburg on Prince of Wales Island (southeast Alaska), there is a park with twenty totem poles. They are Northern Haida, or Kaigani, poles which were collected from their original locations in abandoned, remote coastal villages and brought to Hydaburg and restored under a Works Project Administration Civilian Conservation Corps (WPA-CCC) project in the 1930s. In Klawock, farther north on Prince of Wales Island, only twenty-one Tlingit poles remain. Of these, two have fallen and broken. These poles were also collected from remote coastal villages from around Prince of Wales Island and brought to the new cannery town of Klawock. They are currently in poor condition. Figure 2 reveals flaking paint and deteriorated wood of Raven Pole 6.

In Ketchikan, there are three collections of totem poles. One collection, partly housed indoors at the Totem Heritage Center of the city's Museum Department, includes thirty-three important totem poles collected from the surrounding region. Newer poles, by artists Dempsey Bob and Nathan Jackson, stand in public sites outdoors. The Dempsey Bob totem pole in front of Ketchikan's library depicts Raven stealing the sun. The Nathan Jackson pole at the Totem Heritage Center tells the story of Fog Woman and the first salmon. The other Alaskan totem pole sites at Saxman and Totem Bight are outdoor parks. At Totem Bight (Fig. 3), a state park, there is a pole carved (1947) by Haida artist John Wallace, who was the head carver of the Civilian Conservation Corps restoration project in Hydaburg. These poles are now maintained by Alaska State Parks.

*Figure 3*

Totem Bight, a park managed by the Alaska State Parks, located just north of Ketchikan.



Throughout the Pacific Northwest of Canada also, only a finite number of historic poles remains, generally in very poor condition. Currently, the poles in the Alert Bay Burial Grounds on Cormorant Island (Fig. 4), are actually out-of-bounds for any form of intervention. Even the action of photographing the poles requires permission from the chief of the band.

There are significant collections at the University of British Columbia Museum of Anthropology in Vancouver and at the Royal British Columbia Museum in Victoria, and smaller collections in other communities throughout British Columbia and in the state of Washington. Totem poles have been sent as gifts to cities and nations in other parts of the world as ambassadors of the native culture, but the total number of historic poles in the world is small and, all too frequently, another one falls and disappears from the record.

---

## Meaning and Memory

In anthropological terms, totem poles are visible proof of family lineages. They document the origins of legends or memorable adventures and declare the rights and privileges of their owners. In the linguistically diverse oral cultures of the Pacific Northwest, they served as referent memory—history carved in wood.

Memorial poles and mortuary poles are both directly concerned with memory. The memorial monument is a category of historic object that is charged with ethical issues. Gravestones, commemorative monuments, and war memorials are surrounded with issues concerning their commission, dedication, and preservation; totem poles have similar characteristics. Although they contain symbolic adaptations of spiritual figures embodied in bird, animal, and mythical figures—often with some human characteristics (Fig. 5)—they nevertheless embody the function of memory in their representations of events and stories of the past.

Contemporary poles often have new, nontraditional images that depict modern cultural issues and events, but the contemporary concepts of carvers are still based on the traditional themes and format of the his-

*Figure 4*  
The Nimpkish Burial Grounds at Alert Bay, British Columbia. Decisions remain to be made about the preservation of the memorial poles in the cemetery.



*Figure 5*

A reproduction Blackfish and Brown Bear pole, Klawock, Alaska. Note the paint deterioration and the plant growth on the surface.

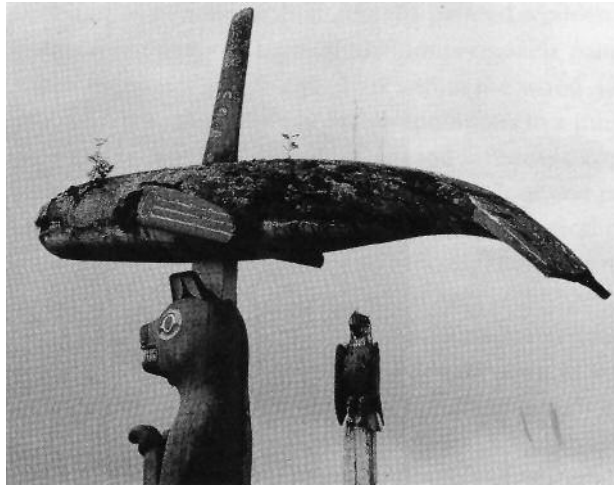

toric poles. The contemporary poles refer back to the historical art of the past and therefore are also preserving the memory of this past artistic style, while continuing to fulfill the function of the story. The telling of a story that was completed in the past continues to evolve from its completion; the history continues to become history.

Social scientists currently are developing important new theories about memory in the area of psychological and sociological research. It is important, in a similar way, to seriously consider and study the role of conservation treatments in relation to memory and the validity of history. After all, memory is considered to be of such import because of the belief in history's value.

---

## Painted Memory

Although it is known that some poles were not painted, many of the historical poles were at least partially painted originally. Investigations have revealed that some of these were later overpainted entirely. Other poles were entirely painted at the time they were created (Fig. 4). Without careful analysis, misunderstanding about the original painted decoration can lead to incorrect identification. For instance, totem poles in Klawock were moved there from historic village sites, and then restored (Fig. 6). The techniques of restoration included adding new wood to deteriorated areas, followed by recarving and repainting. Since the alterations were not documented, it is now extremely difficult to determine which parts of the poles might be original. It is believed that the poles at Ninstints World Heritage Site were never painted, and it is known that a group of three twenty-five-year-old K'san poles, owned by the Vancouver Museum and located out-of-doors in Vancouver, were never painted. However, paint applied to a carved motif enhances the imagery and creative meaning. A Tlingit bear pole from Tongass Island, now located in Ketchikan, reveals traces of early paint that, having never been restored, provides evidence of the effects of weathering on nineteenth-century paint. The painted surface has not been treated, other than a surface dry cleaning, carried out in 1988 by the author.

Paint has both symbolic reference and decorative purpose in telling the story of the totem pole. The meanings and associations of paint on totems are known by anthropologists and have been recorded from oral

Figure 6  
The Totem Park at Klawock, Alaska.



traditions among the carvers and artists of the Pacific Northwest. Edward L. Keithahn (1945:76) reports that “totem poles were painted with a type of fish-egg tempera, consisting of a mineral pigment mixed with a mordant of fresh salmon eggs and saliva. The colors originally were red, black, and green or blue. The red was obtained from hematite, the black from graphite and carbon, and green/blue from various copper ores common in the region.” Each color has a place in the history of totem pole manufacture.

The formulation and physical qualities of the paint give an indication of its age. The early paints made from earth and mineral colors, with salmon roe and saliva as binders, were used at around the same time as were organic colors from berries, bark, or blood. Examples of old paint can be found, weathered but unchanged by intervention, in museum collections worldwide. Paint was a very early trade item on the Northwest Coast. Around the end of the nineteenth century, commercial paints were introduced when industrial fish packing companies moved into the region.

The mild, wet climate of the Northwest Coast does not permit a very long lifetime for paint films. During the past ten years, technical studies have been conducted to examine and describe the components and media of paints used on objects and totem poles of the Pacific Northwest (Howatt-Krahn 1988). Conservation scientists at the Canadian Conservation Institute in Ottawa have been analyzing paint samples, and there is now extensive literature available on the properties of historic paint films, their components, and their degradation. This information is valuable for the preservation of existing paint surfaces and for understanding the technology of early paint manufactured in the Pacific Northwest.

---

## Conservation Problems

In some areas of this coastal region, it rains two hundred days of the year. The annual rainfall accumulation can be 250 cm or more (Ketchikan’s average yearly accumulation is 386 cm). Therefore, the major problem for conservation of the outdoor totem poles is deterioration at the paint-wood interface. Where the paint meets the wood, moisture becomes trapped and the processes of deterioration begin (Fig. 7). The application



*Figure 7*  
Detail, back of fishtail on top of Sockeye Salmon Pole 11 at Klawock, Alaska. Condition recorded in 8 July 1994 examination.

---

## History of Totem Pole Conservation

of overpaint and the use of nonpermeable paint also contribute to the problem. When moisture enters the painted wooden surface of a pole and then cannot pass out through the nonpermeable paint film, the trapped moisture nourishes biological growth in the wood. Once the pole is brought indoors to the dry, stable conditions in a museum environment, degradation of the paint and the wood is reduced considerably. However, this is a compromise with the original outdoor and public purpose of the totem pole. It can also be an economic and physical compromise to properly house an old totem pole indoors, especially for museums with small collections and limited financial resources.

Once painted surfaces have deteriorated out-of-doors, efforts to return them to their original condition, or even to stabilize their condition, become very difficult. This difficulty is usually compounded by the nature of the underlying wood substrate, which is affected by the environment. Factors that affect the preservation of materials often mirror the natural process of life itself, a cause-and-effect system well understood by the indigenous society that created these works. The notion of time dictates the cause-and-effect system of any culture (Laforet 1993).

The history of conservation treatments for totem poles in Canada begins with the efforts of the National Museums in Ottawa and the Canadian National Railway. Their restorations were conducted in the 1920s and are recorded in reports by Marius Barbeau (1990). The Royal British Columbia Museum in Victoria has gathered conservation records by anthropologists and conservators throughout the years. As first chief conservator of the museum (then the B.C. Provincial Museum), Philip Ward was responsible for several projects in the 1960s and 1970s. Richard Beauchamp, Mary Lou Florian, and Valerie Thorp, respectively, have directed conservation services from the late 1970s through to the present. In Vancouver, conservation projects have been carried out at the University of British Columbia Museum of Anthropology and at the Vancouver Museum, which is responsible for an outdoor display of totem poles in Stanley Park. In Ottawa, research and treatment projects continue to be carried out in the laboratories of Canadian Parks Service, the Canadian Conservation Institute, and the Canadian Museum of Civilization. Other projects to preserve totem poles have been conducted by many museums elsewhere in Canada and in other centers around the world.

The author's involvement with the conservation of outdoor totem poles has included treatments and recommendations for preventive measures and record keeping within maintenance programs. Treatment projects to stabilize wood and secure paint have been provided for totem poles that are now housed indoors at museums and cultural centers. Emphasis has been placed on environmentally sensitive approaches to treatment, with minimum intervention, and maintenance-and-prevention programs. An effort to incorporate the native world view into established Western theories of preservation has been practiced for several years. Maintenance treatments and recommendations for storage and display have been provided for several collections in the Pacific Northwest region. Treatments to conserve the historic poles are occasionally being accepted, but the cost of conservation programs and appropriate housing for the old totem poles is still a limiting factor. Now, at least, some understanding of

the concepts of native culture in relation to preservation is being more widely appreciated.

Conservation treatments have included consolidation of the wood structure and of paint films on totem poles at the Totem Heritage Center in Ketchikan. Conservation of a painted housefront in Sitka, Alaska, for the National Park Service demonstrates the stages of a paint consolidation treatment. First, stabilization of the wooden substrate is done using dowels and consolidants, following a gentle, dry cleaning. The soft wood in deteriorated areas is then injected with poly(vinyl butyral) Butvar B-90 in ethanol. Finally, the paint is consolidated to the wood surface with Acryloid B72 in acetone, applied first with brush and then as a fine mist spray.<sup>1</sup>

The same methods have been used for other objects, such as the Tlingit carved bear on the top of a plain round pole from Tongass Island, now in the Ketchikan Totem Heritage Center. This type of treatment, involving the injection of poly(vinyl butyral), can be conducted only on the dry wood and paint of an object that has been moved to a sheltered indoor environment. Polyvinyl butyral will not function as a consolidant in wet wood. Poly(ethylene glycol) (PEG), however, has been used successfully to structurally stabilize wet wood.<sup>2</sup>

Native elders, through hereditary rights, are responsible for decisions regarding the disposition of totem poles. In some cases, they have expressed a wish to be able to witness the gradual and natural decline of the wood and paint in their original placement. An example is the Haida decision regarding the mortuary and memorial poles still located on-site at the Ninstints World Heritage Site on Anthony Island, in the Queen Charlotte Islands. This site is one of the few remaining original villages where poles were traditionally erected. An ongoing program to manage the site is conducted through the Haida Watchman program, in partnership with Canadian Parks Service and the Skidegate Band. The program honors the native point of view, permitting the poles to slowly deteriorate. The site is maintained by the Haida Gwaii Watchman, a native resident who is appointed to supervise the site and keep the poles free of extraneous biological growth.

When representation of a story is the most important aspect to preserve in a totem pole, the option of total restoration results. This operation may include the removal of all deteriorated wood, or as much as necessary, replacing it with new wood, which is then carved to match the original. The result, in terms of materials, is an assemblage of old and new wood, adhesive, and fasteners. With this kind of treatment, the visual representation of the story or theme of the pole is preserved; but, is this not extremely excessive intervention? Such intervention can be justified through the need for public safety in exhibition locations. If the object tells a story, then the imagery of the surface must be preserved to faithfully tell it.

An alternative method of preserving the story of the totem is recarving or reproducing the pole. Elders of a tribe may decide to permit a new pole to be carved to replace one that is no longer safe to leave standing. The Raven and Black Fish pole in Klawock is an example of a recarved pole. Artist Israel Shotridge was selected through hereditary rights to reproduce the pole. His reproduction is an accurate replica of the original, except for a slight addition carved on the fin of the Black Fish. The addition is a portrait of his young daughter. In another case—the Chief



Johnson pole of Ketchikan, which Israel also reproduced—the new pole replaced the original at the outdoor site. The old pole was placed in storage. The status of the old pole now becomes questionable in terms of significance. Is it still an original artifact that should be preserved, or is it like a “de-accessioned” item, removed from the culture? The Chief Johnson pole, partly because of its length (nearly 18.29 m [60 ft.]) and partly because of its ambiguous identity, is now stored under a leaking deck, open on three sides to Alaska’s weather.

Another issue that affects the role of conservation is the question of authenticity that surrounds poles that have been restored in situ by recarving new wood installed on the original pole. Such restorations were carried out in the past, and no written records of these earlier treatments were kept; rarely were approvals of treatment proposals given and/or descriptions of the before-treatment conditions made. As a result, details of the treatment, including exact dates, often are not recorded. When artifacts that carry questions about their treatment or original materials are placed in the same collection with documented ones, the latter often receive better attention. The preservation principle of universal care for objects in a collection is then changed to a hierarchy of care that favors the most authentic.

The Haida position for the Ninstints World Heritage Site is very important to bear in mind with regard to present and future criticism of conservation theory and practice in the preservation of totem poles. In Haida philosophy, the concept of time passing acknowledges and honors the process of life and death and gives regard to the artists and the society of the past. The practice of preserving surface features does not acknowledge the past represented by the whole totem pole; rather, it rebuilds the artifact in the present as a new object. By denying history evident through aging, the impression that is created through the practice of surface rebuilding—when compared to the Haida practice of overall preservation of the old poles and their environment at Ninstints—is not of time passing or of the past, but only of a newly built present.

Although the very old poles remain untreated at Ninstints, their story continues, giving new meaning to the present. The choice of non-intervention at Ninstints is as significant to the history of those poles and that community as intervening with new, structurally stabilizing adhesive and wood. These two choices—to intervene with treatment or to provide treatment that does not actually disturb the artifact—occupy opposite ends of the theoretical approach to totem pole conservation.

---

## Conservation Ethics in Conflict

The ownership of memory—and the right to tell one’s own story, to change it, even to let the story die—is embodied in the symbolism of totem poles. At the same time, the poles are material objects subject to the ravages of time and, within conservation standards, not only worthy of preservation as sculptures within the context of world art history but also important as cultural and artistic resources for future generations of native and nonnative people. This is the intersection where *memory-stories* contained in the totems coincide and conflict with increasingly urgent and complex choices about preserving the original wood and paint.

Preservation is about memory, just as the stories told by many totem poles represent memory. Traditional conservation places emphasis

on the actual materials of the object for preservation purposes—the totem pole as a distinct object of carved wood and paint—whereas in native culture, preservation of the totem pole is an act of remembering.

Who can decide how a story should be preserved, and who can permit a story to be changed? Don't conservators have a responsibility to intervene, to preserve?

Conservation ethics have been carefully established to define the moral and ethical responsibilities of the conservator in the practice of preserving works of art. A written set of guidelines for correct practice has governed the performance of treatments since the early 1950s (IIC 1968). These conservation guidelines define the limits of care and attention. The conservation ethic is, however, uncritical. It assumes that objects are precious and that all are equal in terms of attention for the purpose of preservation. This assumption is often unrealistic, given the hierarchy of certain objects within different cultures and societies. The profession really has not dealt with the choices that are made in the actual selection that takes place before an object is given conservation treatment. Selection for conservation treatment often determines which objects from history are memorialized.

In examples of conservation projects at the Ketchikan Totem Heritage Center, authority to conduct treatments for objects has been granted by the Alaska State Museum and elders of the family that has inherited ownership. Loose sections of carving were considered safety hazards in need of treatment. More recently, authority to treat other poles in the same collection has been granted by the State Museum in two ways: to the conservator responsible for the treatment; and, with formal blessings and songs, by tribal elders whose family lineages extend (or circle) back to the original owners. Permission of this kind is extremely meaningful to the conservators involved.

On the subject of totems and their preservation, Alert Bay artist Doug Cranmer (1994) recently reflected on a common concern held by contemporary native artists and tribal elders. He wonders, "Who will do the preservation work next?" The poles he re-created, along with Bill Reid, in 1960 at the Museum of Anthropology, University of British Columbia, are still outdoors (Fig. 8) and are now in need of treatment to stabilize deterioration and stop the damaging growth of mosses and plants. Biological growth has contributed to structural deterioration of the wood in several vulnerable locations. Cranmer acknowledges that although the talent to carve new poles flourishes in the region, conservation skills are only lately developing within the native community.

Aboriginal control of park and burial sites and the retained ownership of the stories and crests on poles within museums are a serious and unresolved factor in the conservation treatment of totem poles. Traditional aboriginal opinions about recorded history and the use of the carved and painted totem poles have been researched by conservators and incorporated into their discussions in an effort to acknowledge and respect the culture of the original societies that produced the work. However, the conservation profession, while attempting to honor the original culture, is still governed by the rigid Western (i.e., European) definition of cultural preservation. A different ideological world view is held by indigenous peoples of the Northwest Coast region. The flaking and lost paint that troubles conservators is not so important to a society that describes its history through a different communications system, where a totem pole is a story,

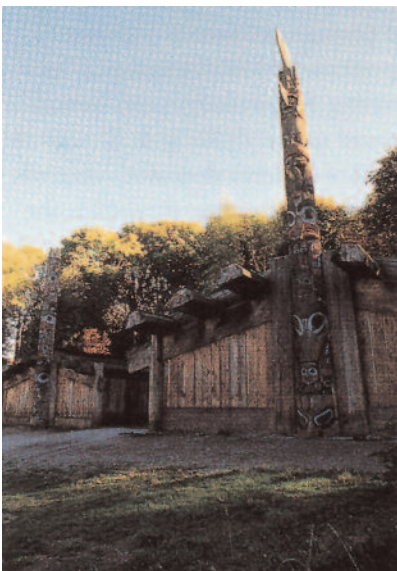

Figure 8  
Totem poles outdoors at the Museum of Anthropology, University of British Columbia. These poles have been reproduced by the team of Bill Reid and Douglas Cranmer.

and the story is about the culture, the rank of its members, their achievements, and their memories. Their cultural viewpoint influences the way they view the European-based conservation profession.

---

## The McLennan Infrared Technique

Surprising revelations from infrared photography have spurred another preservation technology and inspired the interest of native artists to work with the historic techniques of native art. The principle that underlies this technology is, of course, that infrared film is sensitive to heat. Pigments either absorb or reflect the heat from photographic flood lights. Dense mineral-based pigments such as hematite and magnetite absorb heat, while paints such as Chinese vermilion reflect it. Even small traces of pigment can be detected with this method, and distinctions can be made between older paints and those that became commercially available this century through trading. Unpainted wood also reflects heat. These conditions are clearly recorded on photographic film, and they can be observed and considered in relation to what is apparent in natural and raking light.

The work of Bill McLennan (1994) at the University of British Columbia Museum of Anthropology reveals new findings that add to stylistic interpretations of cultural expression. His photographs of paint-decorated objects can penetrate through use-added surface layers that are too important to remove for any examination. Beneath these heavily coated objects, he has found paint designs that have brought a new understanding of the art form.

Previous descriptions of the stylistic qualities of Northwest Coast art have depicted the painted visual form of the designs as being rigid and formalistic. In the 1920s, anthropologist Franz Boas (1929) emphasized formal equations in the art and interpreted the imagery as rule-bound compositions that had little narrative content. Later, Bill Holm further analyzed a formal vocabulary of images and gave names to the iconographic components, such as *formline*, *U-form*, and *ovoid*, in his 1965 book, *Northwest Coast Indian Art: An Analysis of Form*.

By contrast, these infrared photographs have disclosed a unique freedom and risk-taking in the designs. A mature confidence in the application of paint for decorated surfaces reveals the free use of the medium by artists willing to experiment and challenge rigid formalism. The very recent use of this infrared technology illustrates the issue of recovered memory and history within the world of the Pacific Northwest.

Currently, young native artists are working to re-create works from the information recovered in the infrared examinations. Vancouver anthropologist Charlotte Townsend-Gault has studied the implications of these discoveries, and she comments on the fact that more information about the culture is now available. She refers to the technique used by some museums of presenting objects as aesthetic items. Without discussing their meaning, the objects are presented complete in their form and allowed to “speak for themselves.” She notes that the infrared project now defines the important role that the object plays in telling the stories of the culture. As she puts it, “these are not just objects for aesthetic delectation but the repositories of ancestral stories and the rights to those stories” (1993:51).

The issues that are unveiled by infrared examination relate to the present ethical memory role that conservation and the treatment of totem poles must address. Future ethics in this area must take into account the values of aboriginal culture and their concepts of time, nature, material

culture, and memory. Infrared technology has revealed new and important cultural information without disturbing the objects. Conservation treatment needs to remain sensitive to achieving results of similar value through equally nonintrusive means.

---

## Conclusion

Conservation treatments for painted wooden objects have been developed to preserve the physical qualities of the original materials. In many cases, the individual painted objects present unique problems, but for the most part, standard techniques with new procedures can be adapted to achieve a satisfactory treatment. Totem poles, however, present a complex assortment of issues and problems. They are more than works of art; they embody the culture of the native peoples of the Pacific Northwest. The totem poles have several important uses in a culture that incorporates symbols and mythic images to convey the meaning of society and the memories of events and legends. Conservation treatments for these objects raise ethical issues that reveal that the practice of conservation, in fact, also deals with preservation of memory. With totem poles, the responsibility for their preservation should be permitted and approved by the people whose memory is embodied in the object.

As the Western-based conservation profession is now beginning to acknowledge the role of aboriginal peoples in the preservation of their own cultural heritage, so has the importance of the native conservator come to be realized. The result is that conservation is now developing as a profession among the members of the culture that owns the objects. Native conservators are entering the field to share their unique understanding of cultural memory and its preservation. Conservation courses have been given by the author in communities with totem poles. Perhaps the most important outcome of courses such as this has been a growing and shared awareness of the value of preservation programs for these artifacts.

In addition, young artists—such as Robert Davidson, who uses the historic works as a stylistic starting point for his personal development as a contemporary Haida artist (Thom 1994:5–7)—have spoken in favor of preservation in order to keep the objects of the past as lessons in cultural history. Therefore, the culture benefits from the preservation of the totem poles by preserving old stories, which are recarved on new totem poles.

Hopefully, developments such as McLennan's Infrared Technique will provide the inspiration to research and study further techniques to assist in the preservation of Northwest Coast native art.

---

## Notes

- 1 For the use of poly(vinyl butyral) as a consolidant, see Barclay 1981 and Wang and Schniewind 1985.
- 2 There is a great deal published on the use of PEG as a consolidant for waterlogged wood. See, for example, Grattan 1981.

---

## Materials and Suppliers

**Acryloid B72**, Conservation Materials, Ltd., 100 Standing Rock Circle, Reno, NV 89511  
**Butvar B-90 and B-98**, Monsanto Canada, Inc., P.O. Box 787, Streetsville, Ontario, Canada, L5M 2G4.

---

**References**

- 1990 **Barbeau, M.**  
*Totem Poles*. 2 vols. Ottawa: Canadian Museum of Civilization.
- 1981 **Barclay, R.**  
Consolidation of an eighteenth century English fire engine. *Studies in Conservation* 26:133–39
- 1929 **Boas, Franz**  
*Northwest Coast Artforms*. Washington: Bureau of American Ethnology.
- 1994 **Cranmer, Doug**  
Conversation with the author. Vancouver, B.C., 31 August.
- 1981 **Grattan, D. W., ed.**  
*Proceedings of the ICOM Waterlogged Wood Working Group Conference, Ottawa 1981*. Ottawa: International Council of Museums, Committee for Conservation, Waterlogged Wood Working Group.
- 1965 **Holm, Bill**  
*Northwest Coast Indian Art: An Analysis of Form*. Seattle and London: University of Washington Press.
- 1988 **Howatt-Krahn, Ann**  
Field research in the conservation of ethnological collections: An ecological approach applied to polychrome monumental sculpture. In *Proceedings of Symposium 86: The Care and Preservation of Ethnological Materials*, 156–69. Ottawa: Canadian Conservation Institute.
- 1968 **International Institute for the Conservation of Museum Objects (IIC)**  
*The Murray Pease Report: Code of Ethics for Art Conservators*. New York: IIC-American Group.
- 1945 **Keithahn, E. L.**  
*Monuments in Cedar—The Authentic Story of the Totem Poles*. Ketchikan: Roy Anderson.
- 1993 **Laforet, Andrea**  
Time and the grand hall of the Canadian Museum of Civilization. *Museum Anthropology* 17(1):22–32.
- 1994 **McLennan, Bill**  
Conversation with the author. Museum of Anthropology, University of British Columbia, Vancouver, B.C., 10 May.
- 1994 **Thom, Ian, ed.**  
*Robert Davidson, Eagle of the Dawn*. Vancouver: Douglas and McIntyre.
- 1993 **Townsend-Gault, C.**  
News from the Northwest. *Canadian Art* (summer):46–51.
- 1985 **Wang, Y., and A. P. Schniewind**  
Consolidation of deteriorated wood with soluble resins. *Journal of the American Institute for Conservation* 24:77–91.

# The Philosophy of Aesthetic Reintegration: Paintings and Painted Furniture

Wendy Hartman Samet

*Aesthetic reality lies entirely in the appearance of the work of art and its understanding cannot be dissociated from the presentation of the work. . . . The minimization of disturbance [caused by losses], . . . while respecting [the object's] authenticity as a creation and as a historical document is the real critical problem of the re-integration of lost areas.*

PAOLO MORA, LAURA MORA, AND PAUL PHILIPPOT  
CONSERVATION OF WALL PAINTINGS, 1984

ONLY RARELY DO WORKS of fine or decorative art reach the conservator without some degree of damage, wear, or loss. Whether in museum, private, or university practice, conservators sooner or later turn their thoughts, time, and abilities to the object's presentation. This is not as easy a task as may first be assumed; museum goers, owners, scholars, and institutions have various—and at times conflicting—goals. The consideration of painted furniture as a discipline is fairly recent. In searching for guidelines regarding aesthetic compensation, largely a surface phenomenon, the obvious place to look is toward painting conservation. In North America and throughout most of western Europe, compensation is seen exclusively as an aesthetic issue. There is a more complex mandate in the conservation of painted utilitarian objects, however; and the analogy to painting conservation, though useful, is ultimately inadequate. Even the concerns of polychrome sculpture do not apply, as these objects were often routinely repainted. The numerous layers are considered a legitimate part of the sculpture's history, thus the palimpsest that results from losses in one layer, revealing an earlier layer, present additional issues in aesthetic reintegration that are not relevant to either paintings or painted furniture. The three-dimensional, utilitarian, and nonillusionistic components of painted furniture bring their own concerns to bear, and there is a need to look further afield for answers.

---

## The Philosophical Argument for Inpainting

An assumption in painting conservation is that the most skilled conservator is the one who can most sensitively and skillfully restore to a work of fine art its sense of unity and aesthetic purpose without removing all traces of age or patina. Clearly, many varied skills come into play, includ-

ing, but not limited to, the knowledge of a particular artist or period, awareness of how materials may have changed, and how removing a discolored varnish may emphasize or minimize that change, the ability to select an adhesive, knowing when and when not to line, the ability to interpret a cross-sectional sample of paint, and the skill in matching a color or reproducing the merest hint of lost translucency to return a sense of form and space to a figurative work. Much of what conservators do is perhaps not readily understood by the general public, but people do understand the concept of inpainting.<sup>1</sup> Inpainting is the most visible and most comprehensible aspect of a conservator's work. It is curious then that while so much writing and research has gone into other phases of painting conservation, so little has been written on the subject of inpainting. It is as if inpainting were a skill that could not be acquired without divine inspiration or, paradoxically, as if retouching did not matter because it is merely on the surface and can be readily detected, changed, or removed.

Writings on the subject of inpainting that do exist are built on the legacy of Cesare Brandi, who wrote several seminal articles from the late 1940s through the 1960s. At the time of this writing, few of Brandi's texts were available in English, though his views were summarized and expanded upon in *Conservation of Wall Paintings* by Paolo Mora, Laura Mora, and Paul Philippot (1984).

Brandi worked from the notion that the aesthetic of a work of art is characterized by the unity of the form as a whole. The art (the image created by the artist) is different from that of the object (the bits of paint and wood or fabric by which it is rendered). Art, therefore, consists of something greater than the sum of its parts. Even in a mutilated or fragmented work, that potential unity of form, the totality of the art, can be found in each fragment. The purpose of reconstruction is to realize the potential formal unity of the work that exists within the fragments. Brandi maintained that losses in a painting are disturbing because they have a tendency to form a pattern for which the work of art becomes merely a ground, and, as such, they destroy its integral aesthetic unity. This idea of the integral aesthetic unity of a work of art is paramount and forms the basis on which conservation practices are based. Brandi felt that respect for the authenticity of the work means that retouching must always be visually distinguishable from the original at close range. In part, this stricture is a reaction against the excesses of repainting in the past (Mora, Mora, and Philippot 1984:302–3).

Brandi wrote that the role of the restorer is equivalent to that of translator. Thus, the taste and subjectivity of the restorer should not play a role for fear of misinterpretation. In this sense, a painting with losses can be compared to an old and complex text—one that may, by virtue of missing or illegible words and phrases, be open to several interpretations (Mora, Mora, and Philippot 1984:303):

A comparison may be drawn with the restitution of a work in an incompletely preserved text, although in the case of a text, transmission of the word is ensured by the published edition, which is physically different from the original document. This means that the critical restitution never takes place on the manuscript itself but only on the published text, where it is indicated by a footnote. In a work of art, on the other hand, the reconstruction of the image is only possible on the original.



Figure 1  
Example of inpainting using *tratteggio*. Pietro Lorenzetti, detail of throne of *Virgin and Child Enthroned* (Philadelphia Museum of Art, Johnson Collection 91).

In response to Brandi's concerns, several inpainting techniques have been developed and employed. Some involve merely toning large losses in a neutral color that will allow the lacunae to be perceived as behind the remaining pictorial surface, and other techniques are more complex in both their conception and execution. Many of these techniques vary only in seemingly minor points of philosophy and practice, and all rely on the eye to blend at a distance what is distinguishable as individual colors and brushstrokes at close range.

The technique of *tratteggio* was developed at the Istituto Centrale per il Restauro in Rome during the years 1945–50 and is based on Brandi's ideas (Fig. 1) (Mora, Mora, and Philippot 1984:307, 309):

Reconstruction in *tratteggio* consists of reconstructing losses by transposing the modeling and drawing of a painting into a system of vertical hatchings in pure colors based on the principle of the division of tones. . . . *Tratteggio* is a system of small vertical lines averaging one centimeter in length. The first lines, which indicate the basic tone of the retouching, are placed at regular intervals equal to the width of one line. Next, these intervals are filled with a different colour, and then again with a third colour, in order to reconstitute the required tone and modeling by means of the juxtaposition and superposition of colours which are as pure as possible.

Of course, not all types of loss can be dealt with solely by means of *tratteggio*. The technique is inappropriate when the loss consists merely of wear to patina or a glaze or where the losses are so large that vibrations caused by the hatching serve to cause confusion rather than resolution of the form (Mora, Mora, and Philippot 1984:310).

The technique as developed and practiced by Umberto Baldini and Ornella Casazza in Florence is similarly based, but the colored hatchings are not limited to the vertical direction and instead follow the dynamic flow of the image (Stoner 1985).

*Chromatic abstraction* was also developed in Florence by Baldini and Casazza in the 1960s. Its theoretical basis was devised for the *Cimabue Crucifixion*, which had been seriously damaged in the Florence flood. They felt strongly that it was inappropriate to leave this extremely important work as a mere fragment, and yet they were unwilling to deceive the viewer into thinking that the work was undamaged. Chromatic abstraction was their answer to this dilemma. Chromatic abstraction is formulated on the idea that three dominant tones can be abstracted from any painting. These colors, combined in the losses in small strokes that follow the dynamic flow of the image, and in the correct proportions, create the neutral color that blends most perfectly with the painting, making the losses the least distracting without inpainting them imitatively. By the 1980s, with the benefit of hindsight, Casazza did not feel that the technique had been entirely successful (Stoner 1985).

In each of these approaches, the purpose is at least twofold. Obviously, each of these techniques ensures that any reconstruction can be readily differentiated from the original, in the same way as a different typeface may be used in a printed text to distinguish the translator's interpretation or conjecture about missing or illegible text. The second purpose is more complex and less realized. The writings suggest a great reliance on technique to prevent or filter, "through the mechanical nature of the system, any personal expression of the restorer in the spontaneous continuity



of the modeling, brushstroke or the line” (Mora, Mora, and Philippot 1984:309). The assumption that any technique will produce uniform, unprejudiced, and even impersonal reconstructions based solely on the objectivity imposed by the technique is well intentioned but, in this author’s view, naive. Can the imposition of a rigorous, technical process such as *tratteggio* be relied on to filter out the conservator’s personality more effectively than an effort by that conservator to exactly match the original surrounding paint? Even the use of such abstracted methods as developed by the Italians results in part from a twentieth-century, post-Pointillist aesthetic. Although the Moras suggest that when reconstruction of the missing areas becomes hypothetical, the loss should not be reconstructed, they reject the “radical refusal of any intervention on lost areas,” stating that “aesthetic reality lies entirely in the appearance of the work of art and its understanding cannot be dissociated from the presentation of the work. . . . Moreover, non-intervention, which also affects the appearance and legibility of the image, is thus in itself a form of presentation” (Mora, Mora, and Philippot 1984:303, 310, 302). Clearly, this statement can easily be applied to whatever form or level of aesthetic reconstruction is employed.

Paul Philippot, however, in one of his essays in *Pénétrer l’art, restaurer l’oeuvre*, acknowledges that the judgment and sensitivity of the restorer are critical to a reconstruction despite any inherent problems (Philippot 1990:414).

Critical interpretation clearly cannot be limited to a verbal judgment; it must take shape in the concrete act, the execution of the retouching, and must be realized according to the imaginary plan in which one intuitively reconstructs the form. This is where restoration is essentially a work of art requiring practical cultivation of the visual imagination. Despite its critical nature, it cannot, in the final analysis, be divided between pure intellectual decision and pure technical execution. This is where the peril, the drama of the restorer, is revealed. It is necessary that the intuitive reconstitution remains essentially critical; that is to say, it suppresses as much of the practitioner’s personality as possible, something all the more difficult for a sensibility as acute as it must be for this task.

Philippot also acknowledges that lacunae alone are but one of the several types of loss a painting may suffer. He notes that depending on the nature and the style of the work, the loss of even a thin film can confuse modeling. Interruption of the craquelure or the enamel of the paint can cause as much disruption in a Dutch interior as a large gap in an architectural drawing or primitive fresco. Given the nature of the disruption, he makes the radical statement that a subtle glaze or disrupted craquelure should be replaced and that, at times, imitative inpainting is the most appropriate choice (Philippot 1990:413–414, 415).

In English-speaking countries and most of the rest of Europe, invisible inpainting, or inpainting that seeks to visually replicate losses as closely as possible, has become the normal practice, and the ability to do so has become a measure of competency or excellence. As the Italians do not want the distractions of the lacunae, others have no tolerance for the more obvious tracks of the restorer that interfere with their aesthetic experience. Rather than desiring immediate, visual assessment of what is original and what is reconstruction, we rely on “before-compensation”

photographs and ultraviolet light examination to detect inpainting and to identify excessive retouching not confined to areas of lost paint. Imitative or invisible inpainting, ethically practiced, answers the aesthetic requirements of most illusionistic paintings, but does it meet the needs of painted utilitarian objects?

---

### Some Critical Differences between Paintings and Painted Furniture: Issues of Formal Analysis

When the literature is searched for an appropriate criterion for inpainting the various types of loss found on painted utilitarian objects, a rationale based on the problems of illusionist painting may not be entirely relevant. First, the formal differences between traditional, illusionist painting and utilitarian, three-dimensional painted decorative arts objects are profound. The two-dimensional format of a painting is part of the tension of the illusion of three dimensions, a virtual space. With painted furniture, its three-dimensional form is part of the decorative scheme rather than being at odds with it.

As with paintings, two major issues of damage to painted furniture can be addressed with retouching: wear to the surface and severe loss. Brandi's premise that lacunae become a dominant pattern, if not literally a foreground, is as true of painted furniture as it is of paintings. Therefore, with regard to wooden objects, although some might choose to leave older lacunae with oxidized wood below (because they may show age and use without being visually distracting), there are few who would choose to leave lacunae with bright grounds and hard edges untouched. Is there a logic in this? Unless lacunae on painted furniture are so massive as to subsume the object, they are not likely to cause the same kind of disruption that one experiences in a painting. No illusion is destroyed, and the three-dimensional form—as well as the decorative paint scheme—is likely very comprehensible, especially when the design is symmetrical and repetitive. Paint flake loss may even reflect patterns of manufacture. Loss may be indicative of the materials from which the piece was made. (For example, a crest rail made from a piece of wood that contains tangentially as well as radially cut wood might exhibit flaking paint only over the tangentially cut area because it is more reactive to changes in relative humidity than the adjacent radially cut piece.) Or acute loss may be the result of a period in which the piece was not valued and was kept in a poor environment. The problem is one of the ability to interpret the meaning from the loss. Although acute loss may have some relevance to the piece, it is not as direct and comprehensible a correlation as one sees with wear. Devoid of meaning, losses of this nature are distracting; therefore, conservators usually do their best to minimize, if not eliminate, them.

Wear and abrasion present different issues with painted furniture than with paintings. Abrasion to a painting is usually a sign of damage or overcleaning. It is detrimental, in that even the slightest loss of glaze or patina can change a color relationship or destroy the illusion of space. Leaving evidence of wear from intended use on three-dimensional decorative, utilitarian pieces, by contrast, has much to recommend it. Many people like the idea that these objects are old and have a history, as long as the damage caused by that history is confined to the edges or has softly abraded high points and niches, leaving a mellowed, "antique" look without severely compromising the design. Leaving this type of wear visible has merit from a formalist point of view, as well; these patterns of loss are less hard-edged than those of acute loss and are therefore less distracting.

Edges and sculptural forms tend to be emphasized, not obscured. The reasons for the loss are usually readily comprehensible as the result of the intended use and subsequent history of the object (Fig. 2). Therefore, formally, even historically and aesthetically, there is justification in some cases for leaving wear without compensation while inpainting acute losses to some level.

---

## Changes in the Conservation Profession



*Figure 2*  
This Windsor chair, shown after retouching, exhibits paint loss due to patterns of use and wear (Winterthur Museum 65.832).

The professionals consulted in the preparation of this article indicated a greater tolerance for, even appreciation for, leaving the visible marks of age and history as part of the object.<sup>2</sup> This trend seems to come from several sources simultaneously, including a broader concept of what conservation means, as influenced by such diverse fields as the conservation of ethnographic objects and that of contemporary art; changes in some methodologies of art history; forces of the art market; and some very practical concerns.

Years of organized thought and shared experience have led to a maturity, and perhaps growing conservatism, in the profession of conservation. There is an increasing dislike for seeing the conservator's tracks on a painting or an object. It is disturbing to be able to survey a body of work or a collection and be able to date a treatment with some accuracy just by looking at it. Conservators have not always been as anonymous or unobtrusive as they hoped or intended to be. Perhaps consequently, there is a greater willingness to let an object speak for itself without professional help.

In ethnographic conservation, there has been a significant change over the past twenty years in the attitude toward inpainting. There is an increasing awareness that one cannot know the cultural significance of a great number of factors and that the safest course is to interfere with the object as little as possible. Today, the trend in ethnographic conservation is to use a fill only when it is structurally required. Inpainting is generally confined to toning a fill to make it less visually distracting and to act as a visual bridge for the viewer; in general, designs are not carried over fills even in the most schematic way. The idea of noninterference is so important that there is even a reluctance to consolidate friable paint if the low binder quality of the paint is original and the problem can be addressed with proper storage. There is a new understanding that the powdery nature of a paint surface needs to be preserved for its aesthetic, and possibly culturally significant, qualities (Little 1994).

Similarly, issues pertaining to contemporary art have, at times, forced conservation professionals to challenge many of their revered notions about what art is, and what the appropriate interaction with it should be. Although these ideas were not new, especially to conservators of modern art, John Richardson's article "Crimes against the Cubists" (1983), and the responses it engendered, brought to the fore some of the issues of the artist's intent and the need for making conservation decisions on an informed aesthetic basis. In this article, Richardson accused conservators of having ruined many Cubist paintings by wax lining and varnishing. He contended that the conservator's ignorance and a single-minded concern for the physical preservation of the object over—or irrespective of—concerns for the artist's intent and the inherent aesthetic properties of the painting are to blame. Although responses to Richardson's article suggested that his accusations were too broad and not entirely informed, the exchange was one of several forces articulating the need for increased

sensitivity to the diverse aesthetic demands of modern and contemporary art. In contemporary art, respecting the intent of the artist may mean allowing some works to fall apart, while keeping others as pristine as possible. Ed Ruscha was dissatisfied with a painting and left it rolled up for years. Upon unrolling it, he decided that the cracks and flaking paint were what the painting needed. He brought the painting to a conservator to have it stabilized in that condition.<sup>3</sup> Some artists have suggested that some of their works be put away rather than tampered with, in the event of damage to a particular surface (Albano 1993:13). Anselm Kiefer, by contrast, suggests that if a piece of paint or straw falls off one of his works, it should just be stuck back on (Albano 1993:12). In some works of art, the surface or exact color are not considered precious by the artist and are meant to be repainted. Consider, for example, some of Calder's industrial pieces. Ellsworth Kelly has, on some occasions, allowed some of his works to be repainted (Albano 1994). The point is that "one must have developed an appropriate aesthetic sense of the art for which you are steward. The past is littered with negative proof of this statement. The idea that conservation problems can all be solved with 'conservation solutions' is naive" (Albano 1994). Making decisions of this nature means being familiar enough with one's specialty to be able to make the aesthetic judgment to accept a certain amount of damage or change in contemporary art as we do in older works. Acknowledging change and damage—even significant change that we may find in paintings by Reynolds, for example—does not negate the experience of the art (Albano 1994).

---

## The Effect of Recent Art Historical Trends

Recent art historical scholarship is showing trends that may also affect inpainting decisions. Although directions in art history today are diverse, and some are more or less appropriate to the topic of this investigation, the work of Jules Prown in setting out the logic and methodology of what he terms *material culture* is perhaps most relevant, and it has been seminal in the development of new approaches to art historical research. Prown (1982:1–2) put forth the argument that "objects made or modified by man reflect, consciously or unconsciously, directly or indirectly, the beliefs of individuals who made, commissioned, purchased, or used them, and by extension the beliefs of the larger society to which they belonged." Prown (1980:197, 200) maintains that "although a society may prevaricate or intentionally distort actuality in its utterances (journalism, propaganda, diplomatic communications, advertising) or in its pictorial statements . . . a society does not bother to deceive itself or others in such mundane things as most buildings or the furniture or pots that it makes for its own use," and that "style is inescapably culturally expressive, . . . the formal data embodied in objects are therefore of value as cultural evidence, and . . . the analysis of style can be useful for other than purely art historical studies." The methodology demands that the scholar of material culture thoroughly describe the object, make deductions based on that description, and finally, speculate on the meaning contained in the object.

So why does this kind of scholarship ask the conservator to inpaint less and leave more evidence of wear and use? The idea is twofold: The first is not to unconsciously interfere with style, not to impose one's own sort of handwriting on the design or the object, because it is just this sort of unconscious evidence that can be so crucial to interpretation. Second, one is not to eliminate signs of use and wear so as not to subtract

use from the analysis of the object. This is a methodology based on the intense scrutiny of the object itself, and the conservator or custodian of the object is responsible for not losing, even unconsciously, any information the object may contain. Seeing the value in this evidence of time and wear, as well as in style or other formalist concerns, has led the way to an aesthetic wherein the two may be appreciated simultaneously.

The discipline of material culture is but one influence that has had the effect of increasing awareness and appreciation for the “lower” forms of art, including folk or country-style decorative arts. It is in the appreciation of folk art, perhaps, that one sees the greatest tolerance, even reverence, for the marks of age and use. With less emphasis on the individual maker, who is often anonymous, objects may be appreciated as a product of culture and the passing of time, not as the end result of a single individual’s conception. Thus, generations of wear and repainting and subsequent wear all may be part of the object’s meaning and aesthetic. The challenges of cleaning and inpainting these objects are similar to those of polychrome sculpture. One must weigh the value of removing newer layers to reveal older, but perhaps less intact, ones against the aesthetic and historical confusion that can result with the surface of a piece as a nonsensical palimpsest of layers. Even in “higher style” painted furniture, it was not uncommon to repaint or regild a piece as it began to look worn or when styles changed, as evident in an advertisement for William Buttre’s Fancy Chair Store, which reads, “A large assortment of elegant, well-made, and highly refined Black, White, Brown, Coquelico, Gold and Eagle Fancy Chairs, Settees, Conversation, Elbow, Rocking, Sewing, Windsor, and Children’s Chairs of every description, . . . *Old Chairs repaired, varnished and regilt* [italics added]” (Fales 1972:167).

---

### The Influence of Market Forces

The level to which one inpaints painted objects has been affected by several market forces. The rapidly increasing value of painted furniture in recent years has led the serious collector to be somewhat suspicious of a piece that looks too perfect. After all, what they are buying really is the painted surface, and they want to know what they are getting without having to peer through the work of the restorer (Colwill 1994). Similarly, the serious folk art collector wants to see the signs of age on an object (Flanigan 1994). One indication of the increasing monetary value placed on painted furniture is the mere fact that conservators are seeing these pieces brought to their studios instead of to the local fix-it, repaint, or strip shop. Nonetheless, the conservation treatment is relatively expensive and, besides the obvious ethical or aesthetic considerations, cost may be a force in keeping treatments conservative.

---

### “Complete” Inpainting on Painted Furniture

On the other end of the spectrum is the philosophy that suggests that painted decorative arts should be inpainted to look as pristine as possible, emphasizing the original aesthetics of the piece and conveying to the viewer, insofar as possible, what the piece was intended to look like when made. There is certainly validity to this point of view. Presenting the object as pristine, without loss or wear or other signs of its age, tells about history in a different way. It conveys information about the object’s makers and intended owners, including matters of taste and the availability and comparative value of materials. This approach is not at all in conflict with

Prown's notion of the study of material culture. The critical question here is, Must the piece look new or nearly new to convey this information? Which is more confusing, and even potentially misleading: looking through age and wear or looking through contemporary eyes at a contemporary restoration or reconstruction? Would it not be possible to extrapolate the same information with a piece that is less restored?

There appears to be general acknowledgment that an old object that is overrestored looks wrong, like a bad face-lift. This is, in part, because one expects some look of age on genuine artifacts; to have all of them obliterated makes the object ring false. Then there is the insidious problem of anachronism. One can often readily detect even a very proficient and skilled Victorian restoration on an eighteenth-century object, or marvel that the Van Meergen forgeries were ever thought to be true Vermeers. Perhaps frighteningly, we can all too often readily spot conservation treatments and reconstructions that date back only thirty years or so. This is a rather humbling experience. Not only are our skills not as fluent as those of period artisans—let alone masters who practiced these painterly and decorative techniques every day—but, as Prown and the Italians would likely acknowledge, conservators bring their own period sensibilities to the work. Furthermore, professionals are faced with a problem not unlike a problem forgers face: care and attention to detail can tend to make fluid expressions mechanical, rigid, and tight. Though these concerns should not keep conservation professionals from their work, or even from inpainting, these issues should inform the work with a certain amount of humility and sense of perspective. The conservator's interventions are but a small chapter in an object's life, and, in the midst of everyone's best efforts, it is all too easy to lose sight of this fact. Whatever level and style of inpainting is chosen—even leaving all signs of age—the conservator must acknowledge that a given decision is but one solution to a particular set of concerns and that future generations will have their own concerns and solutions.

---

### The Purpose of Treatment

Just as conservators come to their work with their own sensibilities and philosophies regarding reconstruction, as well as those of curators, institutions, and clients, in the end individual objects present problems unique unto themselves. Somehow, the actuality of the object and its particular circumstances must be evaluated and integrated into a coherent treatment.

The foremost consideration should be, Why is this object being treated? Is it for a didactic or connoisseurship exhibition, or for the home of a private collector? Where it will be used? If it will be part of a museum gallery setting or period room, what is the level of aesthetic compensation of the room as a whole?

---

### The Role of Style

Most of the people interviewed by the author felt that different styles of painted furniture legitimately had different aesthetics, which called for different approaches to aesthetic compensation.<sup>4</sup> Gregory Landrey, then senior furniture conservator at the Winterthur Museum, gave as an example a pair of high-style, Baltimore-painted klismos chairs (Fig. 3). For these chairs, the artistic intent is found in the detail and finesse of the painting, as well as in the form. To leave the detail illegible would change the intent and meaning of the piece. Likewise, Pre-Raphaelite art furniture is perhaps best inpainted to the same degree as an illusionistic paint-

ing. Such a piece is likely to contain individual, illusionistic paintings, the intention being to present a piece equivalent to fine art. These same concerns may simply not be applicable to a primitive corner cabinet that was meant to be part of the architecture of a room and repainted along with the other architectural elements. Although very interesting, it may not be as critical that the current presentation surface be the same color as the original.

---

## The Condition of the Object

The next consideration is certainly the condition of the object. Time, tastes, and past use have often not been kind to painted furniture. Not only is the conservator of painted furniture likely to uncover many re-coatings, as well as wear or extensive flake losses that may or may not be active, but there will also likely be several layers of extensive overpaint (including several separate applications over the present surface), gouges, stripped or barely extant gilding, oil gilding over water gilding, bronze powder paint of various media over anything, and so on—the list is long. Most damaging are those restorations that involved scraping, sanding, or stripping away all or part of a damaged original surface. Furthermore, decisions regarding compensation cannot be made until the conservator can assess the possibility of safely removing more recent, unwanted coatings or inpainting. Even if it is possible to safely and effectively remove later coatings, the professional must decide if it is sensible to do so based on current understanding of the condition and legitimacy of the layers below, as well as probable budget and time limitations. Only after these issues are addressed can the most appropriate level of aesthetic compensation begin to be assessed.

---

## The Sequence of Inpainting

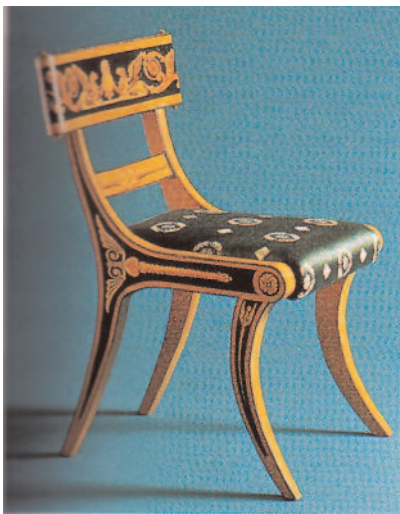

Figure 3  
A finely painted klismos chair from the Baltimore firm of Findlay Brothers, 1815–25 (Winterthur Museum 92.29.1).

In the book *Conservation of Wall Paintings* (Mora, Mora, and Philippot 1984:306–7), it is suggested that lost patina and wear be inpainted before treating acute losses. The author recommends that, on most paintings and painted furniture, the opposite approach be taken. Going so far as to replace patina and wear predetermines the level to which one will need to inpaint the entire object, rather than allowing the piece to speak for itself. It is this predetermined outcome, this inpainting to a preset level, that is likely to give the object a false ring and to result in the application of more restoration paint than is required to visually reintegrate the object. This is truly imposing the idea of the restoration on the reality of the object. To inpaint the subtle traces of wear or lost patina may simply not be appropriate on a particular piece of painted furniture. Accepting the notion that acute losses are extremely visually distracting, it is very difficult to assess the nature of the patina or the subtle nuances of wear while lacunae exist. The author suggests that the largest or most distracting losses should be addressed first, and this may be limited to initially filling and toning those losses. The conservator can then simply continue the process of addressing the most visually distracting losses, working them a little at a time, until the piece reads as a coherent whole.

This is essentially the way in which most paintings conservators address inpainting, the only difference perhaps being the extent of reconstruction required to achieve the coherence and legibility of the object. Certainly there are some tricks that often aid in achieving the legibility of a piece of painted furniture. Restoring disrupted or missing striping or

penciling, for example, can cause otherwise more distracting areas to visually recede into the background. Interrupting a large ring stain or crack to carry out a design element that it has disrupted may suffice to visually eliminate the stain or crack without actually covering it with paint. The conservator may often find that there is a weak link in the chain of the restoration process, so to speak—one material, a layer of paint that cannot be removed, or remnants of gilding that should not be tampered with—that sets the key in which the reintegration will be played (Bigelow 1994).

---

## Conclusion

In attempting to find criteria for the aesthetic compensation of painted furniture, it is clear that there is no entirely satisfactory analogy to be found within the existing disciplines of conservation. Although aspects of painting conservation and ethnographic conservation, as well as issues in contemporary art, may be useful, the utilitarian component and unique character of painted furniture require that it be considered on its own terms. Even within the category of painted furniture, there is great variability. The style of the object, the purpose or audience for which the object is being conserved, and the condition in which it is received all affect the degree or style of inpainting that will best unite the piece visually. To avoid excesses of shortsightedness, conservators must rely on their own cognizance of the role they play and be humbled by their ability to abuse it, even if unintentionally. In the author's opinion, both Brandi and Philippot were correct. Brandi was right in his assertion that each artistic work contains an aesthetic unity and meaning that is greater than the sum of its parts and that that aesthetic unity is present in the fragments of incomplete works. Philippot was astute in his claim that the aesthetic unity of a work can be understood and, in part, restored by the conservator who is skillful as well as knowledgeable, and developed in his or her sensibilities.

---

## Acknowledgments

The author expresses her gratitude to her friend and teacher, Joyce Hill Stoner, for her rigorous mind and her depth of knowledge about the fields of conservation and art history—and in this instance the use of some of her personal journals and recollections—all of which she shares with thoughtfulness and enthusiasm. The author is also indebted to Deborah Duerbeck, student and then colleague, who presented this paper at the Painted Wood Symposium. Over the two years they worked together, Duerbeck's quiet ways, sharp mind, excellent skills, and critical thinking helped the author to develop her own approach to the problems of painted furniture.

The author is deeply indebted to all those who graciously granted interviews in preparation for this article,<sup>5</sup> giving generously of their time, thoughts, and expertise. They are Albert Albano, Gregory Landrey, Margaret Little, and Michael Podmaniczky of the Winterthur Museum; Deborah Bigelow of Deborah Bigelow Associates; Susan Buck of the Society for the Preservation of New England Antiquities; Stiles Colwill, president of Colwill-McGehee; Brian Considine of the J. Paul Getty Museum; Wendy Cooper of the Baltimore Museum of Art; J. Michael Flanigan, Antiques Dealer; Sian Jones, Art Conservation and Technical Services; Frances Safford of the Metropolitan Museum of Art; Joyce Hill Stoner at the University of Delaware; Robert Trent, independent consultant; and Gregory Weidman at the Maryland Historical Society.



---

**Notes**

- 1 *Inpainting* is the term used in conservation to indicate retouching of lost areas of paint. It was coined to specifically convey the notion that retouching by the professional conservator is strictly confined to areas of loss and does not extend over original paint.
- 2 Sixteen individuals professionally involved with the issues of aesthetic compensation from the fields of paintings, furniture, modern art, and ethnographic conservation, as well as curators and dealers, were informally interviewed by the author for this paper (see Acknowledgments). All were interviewed in hopes of gaining insights into relevant issues and alternate points of view. This process was not intended to be either exhaustive or statistically representative of the views of all conservators or related professionals. Most of those consulted felt that signs of age and wear that did not interfere with aesthetic appreciation were appropriate, and each cited several influences, as is noted here.
- 3 The conservator was Denise Domergue.
- 4 Of the sixteen professionals interviewed, two felt that pieces should be made to look as similar as possible to the way they looked at the time they were made. They felt that this was the best way to convey the intent of the piece and the times in which it was made.
- 5 Affiliations of the individuals included in this list are as of the time of this project.

---

**References**

- Albano, Albert**
- 1993 *Metier perdu, mauvaises matières de la prétendue fragilité des oeuvres d'art contemporain. Annales d'Histoire de l'Art et d'Archaeologie* 15:7–24.
- 1994 Conversation with the author. Winterthur Museum, Winterthur, Del.
- Bigelow, Deborah**
- 1994 Telephone conversation with the author.
- Colwill, S.**
- 1994 Telephone conversation with the author.
- Fales, D. A.**
- 1972 *American Painted Furniture, 1660–1880*. New York: E. P. Dutton.
- Flanigan, M.**
- 1994 Telephone conversation with the author.
- Little, M.**
- 1994 Conversation with the author. Winterthur Museum, Winterthur, Del.
- Mora, P., L. Mora, and P. Philippot**
- 1984 *Conservation of Wall Paintings*. Boston: Butterworths.
- Philippot, P.**
- 1990 Le problème de l'intégration des lacunes dans la restauration des peintures [The problem of the integration of lacunae in the restoration of paintings]. In *Pénétrer l'art, restaurer l'oeuvre: Une vision humaniste. Hommage en forme de florilège*, ed. C. Périer-D'Ieteren, 413–19. Kortrijk, Belgium: Groeninghe.
- Prown, J. D.**
- 1980 Style as evidence. *Winterthur Portfolio* 15(3):197–210.
- 1982 Mind in matter: An introduction to material culture theory and method. *Winterthur Portfolio* 17(1).
- Richardson, John**
- 1983 Crimes against the Cubists. *New York Review of Books*. 30(10):32–34.
- Stoner, J. H.**
- 1985 Manuscript and videotape of lectures by Ornella Casazza, the J. Paul Getty Museum, Malibu, Calif., 25, 27 June.

# Conservation of Folk Art: Shelburne Museum's Collection and Approach

Valerie Reich Hunt

**T**HE SHELburne MUSEUM in Shelburne, Vermont, founded in 1947 by the pioneer collector of Americana, Electra Havemeyer Webb, today encompasses some eighty thousand artifacts presented in thirty-seven exhibit buildings and historic structures within a 16.2-hectare (40-acre) park. The museum's extraordinary collection of American folk art includes quilts, weather vanes, decoys, carousel animals, cigar store figures, trade signs, ship carvings, painted furniture, toys, and horse-drawn vehicles. J. Carter Brown (1987:6), director emeritus of the National Gallery of Art in Washington, D.C., has called Shelburne "one of the great combined repositories of American arts, architecture and artifacts."

---

## A Folk Art Collection Is Born

Electra Havemeyer Webb was born into a privileged life. Her parents, H. O. and Louisine Havemeyer of New York, were passionate collectors of European Old Master and Impressionist paintings. Their collection ultimately enriched the Metropolitan Museum of Art. Electra inherited the collecting instinct but quickly developed very different tastes. She purchased her first tobacconist figure at eighteen and had it delivered to the family estate. Although she was immensely proud of her first acquisition, her parents recoiled in horror. When they exclaimed, "What have you done?" Electra Havemeyer replied, "I have bought a work of art" (Havemeyer 1958). Her early interest in folk art grew into a lifelong mission to collect and preserve the art and artifacts of early American life. She married J. Watson Webb of Vermont in 1910 and, as she raised five children, she filled the family home with artifacts, including rugs, painted furniture, and sculpture (Fig. 1). Her children recall that the family indoor tennis court slowly filled with tobacconist figures and other sculpture that could not fit into her house. It was apparent that Electra was destined to build a major museum, and she went about this with the same enthusiasm she had shown at eighteen. She acquired land in Shelburne, Vermont, in 1947 and moved the historic, early-nineteenth-century structures she had collected to this site, where they would house her ever growing collection of Americana.

Electra Havemeyer Webb was clearly one of the first collectors of American folk art who was willing to declare it art. "My interpretation is a simple one," she wrote in *Art in America* (1955:15):

Figure 1

Electra Havemeyer Webb and J. Watson Webb at home in the 1930s with a small collection of folk sculpture. At the far right of the photograph is a tobacconist figure of a Turkish woman, discussed in this chapter.



Since the word “folk” in America means all of us, folk art is that self-expression which has welled up from the hearts and hands of the people. The creators can be rich or poor, professional or amateur, but in America, and particularly in Vermont, they are still known as “folks.” Their work can be exquisitely wrought or it can be crude. Perhaps the creators did not think of it as art, but I am one who has thought so for approximately fifty years.

Unlike most other early folk art collectors, who concentrated on paintings, Electra Havemeyer Webb was strongly interested in sculptural pieces. Her collection is recognized for the large numbers of each type of artifact she acquired.

The museum officially opened in the 1950s and within a decade became the leading visitor attraction in Vermont. A large building, the Stage Coach Inn, built in 1783 and moved to the museum in late 1949, became home to her collection. In her enthusiasm to share the collection with the public, she created exhibit spaces where visitors could wander around the artifacts and have the same intimate contact with them that she had enjoyed in her home. Nearly every folk art object the museum owned was on display, filling the two main floors, the attic, the exterior porches, and the basement of the Stage Coach Inn. In terms of exhibit design, there were few models to follow at the time.

---

## Defining Collection Care: The Early Years

In her museum plans and design, Electra Havemeyer Webb never imagined that visitation would grow to 150,000 annually, and by the 1970s it was obvious that the collection was beginning to suffer. The deteriorated condition of the folk art objects was partially the result of poor environment and less than ideal exhibit practices, which lasted many decades. Fragile painted surfaces were damaged by museum visitors seeking not only a visual experience but a tactile one. During the 1950s and 1960s, the maintenance staff tried their best to care for these objects. Unfortunately, the field of art conservation was in its infancy and museum standards for collection care had not been defined. At Shelburne, painted wooden artifacts were routinely coated with a linseed oil mixture, a popular remedy

that was believed to preserve wood. It also served as a “varnish” that enriched the colors of the paint. In time, however, the oil oxidized and cross-linked, casting a dark film over hundreds of museum pieces. Though well intended, such early attempts at maintenance gradually compromised the condition of the collection.

During the museum’s first two decades, there was also little understanding about proper environments for artifacts. In the early 1960s, an electric baseboard heating system was installed in the folk sculpture galleries at the Stage Coach Inn for the comfort of museum staff and visitors. As heat was turned off and on, the relative humidity in the building fluctuated sharply, which resulted in structural damage—such as splits—and in embrittlement of glues and detachment of painted surfaces. Moisture problems and inadequate ventilation also contributed to deterioration.

A condition survey of the folk art collection was carried out in 1984, and a treatment priority list was developed with the assistance of Shelburne’s curators. The ultimate goal was to restore Webb’s collection to the condition it had been in when it had passed from private ownership to the stewardship of a public institution in the 1950s. In addition, a decision was made to correct any inappropriate restorations that had been done before that time. The condition of the collection was determined through a rating system of 1–5, from excellent to very poor condition. Categorization was based on the degree of deterioration and on whether specific conditions could jeopardize the preservation of the object. For example, severely deteriorated objects with structural and surface problems were listed as in “very poor” condition. If the aesthetic quality was compromised by inappropriate surface coatings or grime, the object was given a “fair” condition rating.

Once the rating was established, museum curators assisted in assigning objects a curatorial assessment of their importance to the collection. The final treatment priority list was a combination of the conservation and curatorial evaluations. For example, a high rating on the treatment priority list was reserved for rare or important objects in extremely poor condition that needed immediate conservation in order to arrest further deterioration. The collaborative examination of numerous objects and the different types of deterioration laid the groundwork for a strategy for treating the collection.

---

## Developing a Conservation Philosophy for Folk Art Objects

A wide variety of folk art was fabricated, modified, and used for functional yet decorative purposes. The landscape of towns during the late nineteenth century was rich with trade signs and shop figures advertising the availability of services and goods; weather vanes sat atop barns and other buildings, monitoring the wind; decoys aided hunters; and carousel figures carried numerous riders. As the examination and treatment of numerous pieces progressed, it became obvious that the collection shared a history shaped by the customs and traditions of nineteenth- and twentieth-century society. Many folk art objects are characteristically worn from their utilitarian function, and also from exposure to such outdoor factors as sun, rain, wind, and extreme temperatures, which have permanently altered the surface appearance of wood, metal, and paint. This is an integral part of their interpretation as historical art objects and should be preserved.

The wear and maintenance history of the paint surfaces of these objects is supported by cross-sectional analysis. Within the paint strata,

numerous layers of brilliant colors are separated by varnish layers and grime. Many cigar-store figures, for example, were routinely freshened with a new coat of paint because shop owners considered them to be an important investment and essential for business (Sanborne 1911:29–30, 42–43). The media and pigments of these paints can be identified with modern analytical techniques,<sup>1</sup> and this provides an accurate record of nineteenth-century paints, as well as of different styles of repainting.

The condition of the painted surfaces can also pertain to how the object was used. The paint surface of a decoy, for example, often holds physical evidence of use in the field: small dents, nicks, and paint abrasions; twine impressions in the paint that show it was once anchored within a rig; gunshot holes; old repainted surfaces; paint soiled from years of use in muddy wetlands; even waterfowl bloodstains. During conservation treatment, every effort should be made to preserve these historically significant characteristics, as they are relevant details of how the object was used (aggressive cleaning attempts can ruin such fragile surfaces).

Structural repairs commonly were made during the utilitarian period of the object. For example, many wooden artifacts were strengthened and repaired with small pieces of sheet metal or iron brackets. These modifications can serve to illustrate the resourceful and frugal nature of people who maintained these objects. They also are historically significant and should be preserved.

Conservation decisions must also take into consideration the artist's original intent. As an example, many carousel animals were painted as intricately as they were carved, exemplifying the fine craftsmanship of the period. The job of the painter in a carousel factory was as highly recognized as that of the important and skilled carver. The animals were painted in the same manner as an oil painting with a ground, base coat, and many colors applied in glazes to give highlights and modeling. To respect the artist's intent, a conservation treatment may involve the removal of degraded original and/or nonoriginal varnishes in order to reveal the true colors of the painted surface.

Occasionally, the preservation of historically significant characteristics may be *in conflict with* the artist's or maker's original intent, and thus with the original aesthetics of the piece. If the entire bill is missing from a beautifully carved decoy because it was gunned over, for example, should the damage be left alone and considered historical, or should the bill be replaced to honor the artist's original intent? Without a bill, the decoy can not be fully appreciated as a piece of folk sculpture. Many decoys were also intricately painted, and these surfaces can be significantly obscured by degraded maintenance varnishes or paint loss as a result of use in the field. The decision of whether or not to intervene by cleaning or filling losses is a complex one that must be arrived at through the collaborative efforts of curators and conservators. Often it is possible to achieve a fine balance between preservation of both the maker's intent and significant historic characteristics.

The approach to the conservation of folk art objects at the Shelburne Museum thus encompasses a strong regard for the artist's original intent, historical use, and basic aesthetic qualities. By combining these ideas in a conservation approach, one can increase the educational value embodied in functional folk art objects by preserving their historic integrity to the greatest possible degree. Concurrently, the aesthetic qualities are preserved.

## The Composite Nature of Painted Folk Art: Treatment Dilemmas

Rarely does one find an art or historic object made from a single material; in general, many components are present. Organic, inorganic, and fabricated materials were used by artists and craftspeople to embody a visual concept. In the production of an object, elements were joined with animal glues, wood dowels, and metal components such as bolts, screws, or nails. Surfaces were coated with one or multiple paint schemes with varying media and pigments. The composite structure of many painted wooden folk objects makes them more susceptible to damage from environmental conditions, as well as from handling and maintenance. The conservator who treats composite objects may be required to address problems associated with the biodegradation of wood, insect infestation, corrosion of metal components, unstable paint layers, chemically reactive or incompatible materials, inappropriate surface coatings, and/or poor restorations.

It is well known that all materials react differently to factors such as light, temperature, humidity, and pollutants in the air. For most objects, there is a weak link—some material that can deteriorate or react, causing damage to other materials within the same structure. The goal of any conservation treatment is to arrest deterioration, but to what extent should a conservator intervene with treatment? Knowledge of folk art materials and history is valuable in assessing types of deterioration for the proposal of treatments. For example, tobacconist figures, trade signs, weather vanes, ship figureheads, and other similar objects were often repainted as part of their maintenance (Fig. 2). This usually involved scraping the surface of loose paint and sanding it in preparation for a new layer; therefore, the condition of underlying layers may be weathered and poor, resulting in weak areas within the paint strata. Microscopic examination of such painted surfaces can reveal many weathered layers with characteristic oxidation and cracks within each layer.

As repainting was frequently done with any type of paint available, this has often resulted in interlayer cleavage caused by paint incompatibility. In some instances, the very materials used to fabricate a paint layer will deteriorate because of inherent problems such as the excessive use of chemical drying agents, resulting in severe “islanding” caused by the inability of the paint to withstand its own contraction during the drying process (Stout 1975:40–41). When such problems jeopardize the physical or aesthetic integrity of an object, a conservator’s intervention is ethically justified.

A conservation treatment can be extremely beneficial to both the stability and appearance of deteriorated folk art objects, but such treatment should not change the basic character of the object. Conservators

Figure 2

Cross section of a painted surface from one of Shelburne Museum’s tobacconist figures from the 1870s. The paint strata show numerous paint layers within the sample.

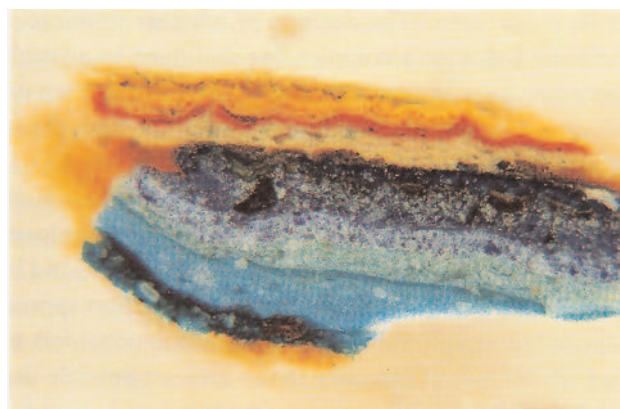

should investigate all treatment options available and assess their promise for rendering the ultimate treatment. In this regard, the choice of materials and methods is an important aspect. For example, painted wooden weather vanes that have endured an outdoor life have a particular appearance that is aesthetically pleasing. The surface appearance also can indicate a history of outdoor use: paint may be lost, and the remaining paint may be oxidized, weathered, and stained, or it may be actively flaking. The exposed wood might be dry and weathered. The application of a synthetic resin, such as Acryloid B72, may effectively consolidate the surface, but such a procedure could darken and saturate areas of weathered wood, significantly changing the appearance of the object. What is described as the *folk art aesthetic*—characteristics of surfaces and materials resulting from use and age—can be ruined by overzealous attempts at conservation and restoration.

Treatments also require consideration of the chemical and physical characteristics of component materials. A problematic combination of materials is wood and iron, a combination commonly found in folk art objects. Ferrous material is damaged by contact with hygroscopic materials such as wood, and the acidity in wood can further accelerate the corrosion process. Paint covering a corroding nail or screw can be stained brown with corrosion by-products. Furthermore, the expansive nature of the corrosion process will eventually cause paint to flake off from a corroding surface. In cases where deterioration of one component is damaging adjacent areas, measures should be taken to stabilize the deterioration while preserving as much as possible of the original materials. What does one do about treating corroding nails, screws, bolts, or other hardware that is buried in the wooden structure? The most conservative approach—that of improving the exhibit or storage environment—would only slow the corrosion process. A more radical approach, for example, may be to excavate the corroding screw, treat the ferrous material separately, and return the screw to the site with a protective coating of synthetic resin. But, should one disturb or sacrifice a small area of the painted surface to accomplish this goal? It is important to fully consider what can be achieved from such intervention. Also, what does one do about disfiguring, brown corrosion stains on a painted surface?

As another example of the need for consideration of the physical characteristics of an object, if a painted wooden trade sign has a history of dimensional movement and associated flaking paint, a conservator should select conservation materials for surface consolidation, filling, and inpainting that will allow some coefficient of expansion. The choice of a synthetic resin for consolidation, a microcrystalline wax mixture for filling, and an acrylic paint for inpainting may be appropriate, as these offer more flexibility than most other conservation materials.<sup>2</sup> One must also consider the eventual exhibit or storage environment of the object when selecting conservation materials. If it is to be exhibited in an uncontrolled environment, will the materials be adversely affected by variations in temperature and relative humidity?

---

## Conservation Treatment Case Studies

The application of ethical decisions and treatment strategies in conservation can be complex. At the Shelburne Museum, past treatments serve as a reference point for current and future conservation decisions, thus establishing a consistent yet flexible approach. The following case studies

illustrate solutions to some of the issues discussed here, including, How much surface cleaning is appropriate? To what level does a conservator inpaint or compensate losses? To what extent does one save historic modifications? Should a conservation treatment change the weathered and deteriorated appearance characteristic of most painted folk art objects?

### *George Washington on Horseback* (painted wood carving, ca. 1780)

Treatment of this Early American folk art carving involved many decisions. First, since the object was decorative and not utilitarian—it was created as a patriotic carving and was probably used as an ornamental piece in a home—the approach to this treatment focused on illuminating the artist’s original intent and improving the appearance of the object.

When it was brought into the lab for treatment, the carving was in poor condition and considered to no longer represent the artist’s original intent (Fig. 3). Although the surface was painted many colors, it appeared dark brown due to a film of aged, cross-linked linseed oil. The physical wear on the object probably was the result of excessive handling. The horse’s ears were missing, as were leather elements from the breastplate and most of the bridle. In addition, the carving had been mounted to a modern wood base with screws.

Initial cleaning tests indicated that the horse was originally white, and a decision was made to remove the linseed-oil coating from the surface. This was done using a solvent mixture of 70% benzine, 20% acetone, and 10% diacetone alcohol, by volume. Complete cleaning revealed an intricately painted surface that was in excellent condition, and revealed, as well, such features as light gray shadows around the saddle blanket and on the horse’s head, where a leather bridle had once been attached. The darkened coating had also masked the brilliant yellow epaulets and buttons on Washington’s uniform and the delicate skin tones on his face. Even if the darkened linseed oil (or “varnish”) layers were original to the object, a decision would have been made to remove them, in the same way that oil paintings are cleaned.

Figure 3

*George Washington on Horseback*, ca. 1780, before conservation treatment. H:54.6 cm; W:17.8 cm; L:50.8 cm. A darkened linseed oil coating obscures the original paint, and physical elements are missing.

Figure 4

*George Washington on Horseback*, after conservation treatment. The artist’s original intent governed the treatment of this decorative folk sculpture.





Varnish layers on paintings and ornamental folk art objects are similar; they were applied to surfaces to protect them and to enhance the appearance of the paint. When such varnish coatings degrade and discolor, they no longer serve these purposes; instead they disfigure the appearance of the original paint. Removal of such coatings is appropriate, but the varnish type should be identified and documented before removal. The decision to remove some historic varnishes may be difficult, as not all degraded varnishes obscure the appearance of painted folk art objects. Certain surface patinas are, in fact, aesthetically pleasing.

Although the initial treatment proposal called for cleaning only, we found it necessary to reevaluate the appearance of the object after cleaning. The darkened oil film had, in fact, unified the appearance of the object, and, through the cleaning process, the painted surface reached a higher degree of preservation than the rest of the object. Other damage, such as the missing bridle and horse's ears now seemed more obvious, and the overall appearance of the object seemed out of balance. This development could not be predicted when the initial treatment was proposed. Accession photographs of the figure provided accurate documentation of its earlier appearance and confirmed that many of the changes could be attributed to handling by museum visitors rather than to age. A decision was made, therefore, to bring all components of the artifact to the same visual state as the painted surface. The addition of missing elements completed the appearance of the carving and were aesthetically important, as they visually reintegrated the horse and rider. By improving the appearance of the object, the artist's original intent was restored (Fig. 4). In this case, the treatment of the painted surface necessitated the conservation treatment of other components.

### **“Luce’s Livery” trade sign (ca. 1870)**

A large double-sided trade sign with the design of a horse in the center and the lettering “LUCE’S.” above and “LIVERY” below, had been in the collection since the 1950s. It was constructed from three pine boards doweled together and framed with wood and iron brackets, from which the sign originally hung. The sign had been displayed for years in the damp basement of the Stage Coach Inn, where seasonal moisture fluctuations had caused dimensional movement of the wood, resulting in extensive areas of flaking paint (Fig. 5). Between 1950 and 1970, an attempt had been made to readhere the paint to the wood with a coat of wax, which only whitened and disfigured the appearance of the sign, and, in 1984, the deteriorating sign was moved to a climate-controlled storage location where active flaking of the painted surface continued. Accession record photographs from the 1950s became a valuable tool for assessing how much damage had occurred over forty years, and they also served as a guide as we attempted to compensate the damage that had occurred at the museum.

Although cross-sectional analysis indicated that areas of the sign had been repainted three times, a decision was made to preserve all the layers and to restore the most recent presentation surface, which probably had been painted sometime between 1870 and 1890. The paint layers contained nineteenth-century distemper paints, which were identified using fluorescence microscopy (Wolbers and Landrey 1987). Working from accession photographs, the conservation team consolidated, filled, and

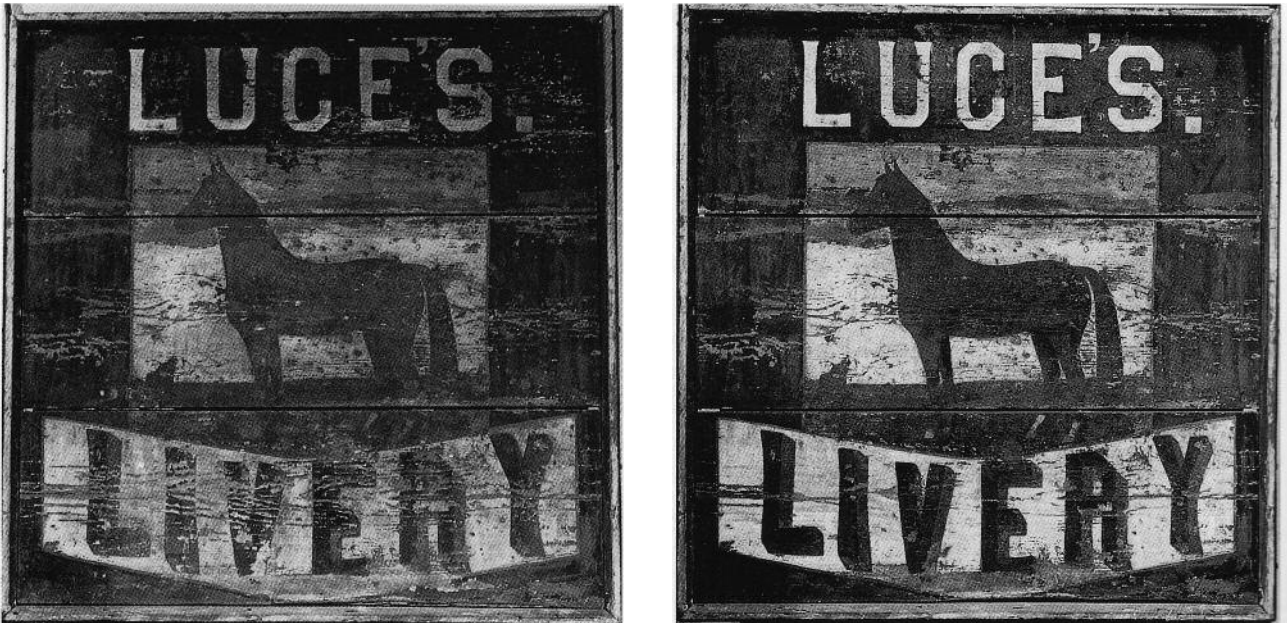

*Figure 5*  
Luce's Livery trade sign, ca. 1870, side 1,  
before conservation treatment. 132.1 cm ×  
132.1 cm. Visible are paint loss in the lettered  
area and a soiled surface.

*Figure 6*  
Luce's Livery trade sign, side 1, after conser-  
vation treatment. The treatment conserved all  
original material and improved the aesthetic  
quality of the sign, while preserving its aged  
outdoor character.

inpainted deteriorated areas until the sign was restored to a semblance of its 1950s accession condition (Fig. 6). Flaking paint was readhered to the substrate with a 15% solution of Acryloid B72 in toluene. As a preventive measure, areas of bare wood were sized with a 10% solution of Acryloid B72 in toluene to help buffer the wooden substrate from relative humidity changes. A small amount of fumed silica was added to the resin to produce a matte appearance, thus maintaining the rather dry surface quality characteristic of most weathered folk art objects.<sup>3</sup>

Once the surface was stabilized, minor surface cleaning and removal of the disfiguring white wax was accomplished with xylene. Wax was chosen as a fill material for losses because it remains somewhat flexible and can withstand some dimensional movement. Where possible, toned wax fills were used to limit the amount of inpainting. The black borders of the sign were originally painted with an oil-based paint, to which sand had been added to create a textured surface; losses in these areas were filled with a combination of wax, black pigment, and sand. Once dry, this material effectively duplicated the color and texture of the border areas.

An attempt was made to visually integrate the important aspects of the sign such as the design or lettered areas; however, older areas of paint loss visible in accession record photographs were not filled and inpainted. While conservators have the technical capability to visually erase all evidence of wear and repair damage, the goal of this treatment was to stabilize and preserve all original material, to interpret the artist's intent, and to improve the aesthetic integrity of the trade sign, while preserving evidence of historic use.

### Tobacconist figure of a Turkish woman (ca. 1860)

Utilitarian folk art objects such as tobacconist figures endured a hard life. The condition of surviving figures was often compromised from the effects of harsh weather, rough handling, and poor storage. To what extent does a conservator intervene? Should large missing elements be replaced? Addressing these and other issues requires careful consideration of the history of tobacconist figures (e.g., initial fabrication by carvers and

painters and historic use in front of tobacco shops) and, ultimately, how the object will be exhibited and interpreted in a museum.

In 1991, treatment was begun on a tobacconist figure of a Turkish woman. It was one of the first items collected by Electra Havemeyer Webb and can be seen in the photograph in Figure 1. The piece arrived in the conservation laboratory in poor condition (Fig. 7). The entire figure was covered with a heavy coating of darkened linseed oil, which totally obscured all original colors and made the surface very shiny. Some areas of the paint were flaking. Most of both feet were missing and the figure listed to one side. It was attached to a wooden base with iron wheels, and an iron bar was attached to the back of the figure for support. There was a large crack down the front, and the proper left forearm was missing.

Cross-sectional analysis of the paint on the cloak showed several similar paint histories; more important, it indicated that there was no original varnish layer on top of the red paint. Instead, the linseed-oil coating applied at the museum in the 1960s lay directly on the paint surface, and it had partially bonded with exposed pigment particles of the red glaze, making cleaning difficult and tedious. A number of different methods had to be used, including mechanical scraping where the film was brittle, a xylene-benzyl alcohol gel,<sup>4</sup> and solutions of organic solvents in varying proportions. The red layer was actually a lightly bound glaze that was extremely sensitive to any cleaning attempt, particularly on the front. The poor condition of this paint surface became more obvious as cleaning progressed—very little remained, perhaps due to a previous cleaning. Extant areas had very little color (the pigment may have been fugitive and therefore damaged by light when the figure was in a shop front). In contrast, most of the red paint on the rear of the figure was intact. The darkened linseed oil had masked this difference in the paint color. A curatorial decision was made to delicately compensate lost areas of red paint on the front to unify the figure's appearance. An isolating varnish layer of semi-matte Liquitex Soluvar varnish was applied to the figure before inpainting with Winsor and Newton acrylic emulsion paints.<sup>5</sup> Since the pale color may have been the result of historical use, the color on this area was not strengthened to the same level as that of the back.

It is unlikely that the damage to the feet resulted entirely from use in front of a tobacco shop. At the turn of the nineteenth century, tobacconist figures became obsolete and shopkeepers turned to new forms of advertising. Many figures were carried off to dumps, burned, or stored in barns. Some were used by early collectors as lawn or porch ornaments. The actual cause of the missing feet on this figure could not be determined; however, for aesthetic and structural reasons, a collaborative decision was made to replace the lost areas so the figure could stand erect without the use of the unsightly iron support bar.

Research into Turkish costume indicated that the figure would have worn a slipperlike shoe with curled tips. Fortunately, the heels were still intact, making it possible to determine the original width, color, and texture of the missing areas. Working from illustrations of this type of traditional dress, much the same way as the carver did, the conservators fabricated the missing front portions of the feet with an inner core of wood and outer core of slow-drying epoxy, bulked with phenolic microballoons.<sup>6</sup> Once hardened, this bulked epoxy was light in weight and could be easily carved with woodworking tools and sanded. The fabricated sections were attached to the figure with liquid hide glue for ease of reversibility, and the

*Figure 7*

Tobacconist figure of a Turkish woman, ca. 1860, before conservation treatment. H:172.7 cm; W:61 cm; D:71.1 cm. The shiny, brown film of linseed oil obscured much of the original paint. Missing feet caused the figure to lean precariously.

*Figure 8*

Tobacconist figure of a Turkish woman, after conservation treatment. The visual interpretation of the surface was improved by removing the linseed-oil varnish and by inpainting and applying a protective varnish. Note the wear areas (paint abrasion, dents, and scrapes) left untouched as evidence of historical use. The reconstructed areas of both feet improve stability and overall appearance.



surfaces of the new areas were textured with acrylic medium and inpainted with acrylic paint to match surrounding areas. The missing forearm and hand were not fabricated because insufficient original material remained. (Although the other hand and forearm were intact and could serve as a prototype, differences in the position of the arms made it impossible to determine the exact design of the missing forearm) (Fig. 8).

In the approach to the treatment of this sculpture, the equal importance of the following factors was acknowledged: the preservation of the aesthetic quality of the artifact embodied in the artist's original intent, its history as a tobacconist figure, and the improvement of its structural stability.

---

## Conclusion

Successful conservation treatments require a carefully considered balance of concerns, including historic evidence of use, the artist's original intent, and aesthetic integrity. In addition, the choice of treatment approach, the methods and materials used, and the anticipated end result of conservation treatment are equally important. In the particular case of folk art treatments, the conservation process becomes a synthesis of these issues.

Furthermore, in any conservation treatment, it is necessary to ask some difficult questions: Is this the best treatment possible? Will the benefits of a proposed treatment outweigh the drawbacks of intervention? Is it possible to wait for better conservation methods to be developed before treating an object?

At the Shelburne Museum, each object is considered within the context of the folk art collection as a whole. Taken into account are the parts of the story the object can offer museum visitors, as well as scholars. Shelburne's large and varied collection of folk sculpture retains a remarkable degree of physical integrity. Although many of these folk art objects lack provenance, they serve as physical documents and contain significant information about materials, manufacture, and historical use. The comprehensive ethical approach to the treatment of painted folk objects discussed in this article ensures the preservation of characteristics unique to this type of art.

---

## Acknowledgments

The author would like to especially thank Eloise Beil, director of collections at Shelburne Museum, for her support and guidance; curators Robert Shaw and Celia Oliver for years of collaborative work, which led to a better understanding of folk art objects; and Valerie Dorge, Painted Wood Symposium program chair, for her encouragement. Over the last decade, many conservation interns and fellows have helped to conserve Shelburne's important folk art collection. The contributions of the following are acknowledged: Catherine Anderson, Keith Bakker, David Bayne, Pamela J. Betts, Nicandra Galper, Rebecca Johnston, Barbara McMurray, Ingrid Neuman, Nancie Ravenel, Annette Ruprect, Mei-An Tsu, Elizabeth Walmsley, and Robyn Woodworth.

---

## Notes

- 1 The work of Wolbers and McCrone, as well as others in the field, has provided the scientific means by which such analysis can be accomplished. See, for example, Wolbers and Landrey 1987; McCrone 1982; and McCrone, McCrone, and Delly 1984.
- 2 Microcrystalline wax is a complex mixture of isoparaffinic and naphthenic hydrocarbons obtained from refining petroleum fractions (see Materials and Suppliers). Winsor and Newton Artist Acrylic Paints are available from most art stores.
- 3 While consolidation of painted surfaces with Acryloid B72 has been used successfully at Shelburne Museum for a decade, many other methods are currently in use or are being developed. Of particular note is the recent work by Hansen, Lowinger, and Sadoff (1993).
- 4 As developed by Richard Wolbers, associate professor in art conservation at the Winterthur/University of Delaware Program in Art Conservation.
- 5 Liquitex Soluvar Picture Varnish can be diluted up to 25% by volume with naphtha. Fumed silica can be added for varying degrees of matte appearance.
- 6 The use of microballoons with epoxy as a fill material is based on the article by Grattan and Barclay (1988). The slow-curing West System Brand 105 epoxy resin and 205 hardener were heavily bulked with West System Microlight 410 filling and fairing additive in the proportion of 1 cup (0.24 l) of filler to 150 ml of mixed epoxy.

---

## Materials and Suppliers

**Acryloid B72**, Conservation Materials, Ltd., 100 Standing Rock Circle, Reno, NV 89511

**West System Brand 105 epoxy resin and 205 epoxy hardener**, Gougeon Brothers, Inc., P.O. Box 908, Bay City, MI 48707

**Liquitex Soluvar Picture Varnish**, available from art stores and from conservation materials suppliers.

**Microcrystalline wax**, Conservation Materials, Ltd.

**West System Microlight 410 filling and fairing additive (microballoons)**, Gougeon Brothers, Inc.

---

## References

- Brown, J. Carter  
1987 *An American Sampler: Folk Art from the Shelburne Museum*. Washington, D.C.: National Gallery of Art.
- Grattan, D. W., and R. L. Barclay  
1988 A study of gap fillers for wooden objects. *Studies in Conservation* 33(2):71–86.
- Hansen E., R. Lowinger, and E. Sadoff  
1993 Consolidation of porous paint in a vapor-saturated atmosphere: A technique for minimizing changes in the appearance of powdering, matte paint. *Journal of the American Institute for Conservation* 32(1):1–14.
- Havemeyer, E.  
1958 Notes from a lecture given at the Antiques Forum, Williamsburg, Virginia, 30 January. Shelburne Museum Archives, Shelburne, Vermont.
- McCrone, W. C.  
1982 The microscopical identification of artists' pigments. *Journal of the International Institute for Conservation—Canadian Group* 7(1–2):11–34.
- McCrone, W. C., L. B. McCrone, and J. G. Delly  
1984 *Polarized Light Microscopy*. Chicago: McCrone Research Institute.
- Sanborne, Kate  
1911 *Hunting Cigar Store Indians in a Taxi Cab*. Boston: Gorham Press.
- Stout, George  
1975 *The Care of Pictures*. New York: Dover.
- Webb, E. Havemeyer  
1955 *Art in America* (May).
- Wolbers, R. C., and G. Landrey  
1987 The use of direct reactive fluorescent dyes for characterization of binding media in cross sectional examination. In *AIC Preprints: 15th Annual Meeting, American Institute for Conservation, Vancouver, British Columbia*, 168–202. Washington, D.C.: AIC.

# Collaborations Past and Present: A Classical Success Story

*Lynne Dakin Hastings and Deborah Bigelow*

**T**HIS ARTICLE ADDRESSES two collaborations that created and conserved an important suite of Baltimore painted furniture for past and future enjoyment. These critical dialogues—between artist and client, curator and conservator—have spanned almost two centuries.

John Ridgely of Hampton and his wife, Eliza, commissioned a suite of painted furniture in 1832 from John Finlay, the most prominent “fancy” furniture maker in Baltimore. The suite is exhibited in the first-story drawing room of the great house Hampton Hall (Fig. 1), constructed in Baltimore County, Maryland, between 1783 and 1790. Hampton was built on the English country-house model, where “show” was considered indispensable. The symmetrical five-part house, a main block with flanking hyphens and wings, served as the heart of an important agricultural, commercial, and industrial complex, with a complementary town house in Baltimore, and another in Annapolis for seasonal use by the family. Hampton was furnished in the grand style, containing a mixture of American, European, and Asian objects.

*Figure 1*

Drawing room, Hampton National Historic Site. Selected pieces from the suite of painted and gilded furniture ordered by John and Eliza Ridgely in 1832. The magnificent sofa with carved and gilded arm supports is unique among furniture documented to the shop of John Finlay of Baltimore and reflects both a Classical derivation and the educated, cosmopolitan taste of the Ridgelys. Featured on the center table is a French silver wine ewer with swan decoration and other Classical design motifs shared with the furniture suite.



*Figure 2*

William Russel Birch, *Hampton the Seat of Genl. Chas. Ridgley [sic], Maryland, 1808*. Engraving of the north side of Hampton, from a painting executed by Birch during a visit in 1803. (Collection of Hampton National Historic Site, HAMP 4645.)



The Ridgelys were a prominent colonial family and part of the ruling hierarchy, but the vast fortune that made Hampton possible was primarily accumulated in the second half of the eighteenth century through industry and trade. In designing his ultimate residence, Captain Charles Ridgely (1733–90) was anxious to reaffirm both his stature and heritage. His stucco-over-stone Georgian countryseat with a dominating octagonal cupola was, prior to the Civil War, the largest house in Maryland (Fig. 2). John Carnan Ridgely (1790–1867) was the third master of Hampton, from 1829 to 1867, having inherited the Hampton estate from his father, Charles Carnan Ridgely (1760–1829).

The 1832 collaboration between Ridgelys and Finlays was the culmination of many years of commercial association, beginning in 1803, soon after the start of the Finlay business. The zenith of Hampton's fortunes, around 1800–1830, corresponded with that of the Finlays' business, resulting in the commission of a suite of furniture upon which John Finlay brought all of his shop's artistic powers to bear.

---

## The Artists

John Finlay (1777–1851) was born in Maryland, and his career flourished between 1799 and 1840.<sup>1</sup> He is listed under a variety of occupations in the Baltimore city directories, beginning his career as a painter, from 1800 to 1801, and last advertised as a chairmaker, from 1835 to 1837. Finlay was also a coach painter, coach and fancy chair manufacturer, and exporter; he owned warehouses and a furniture store, residing and working mostly in the 30–34 block of North Gay Street. For almost half a century, his artistic genius and business acumen helped create a distinguished regional decorative style commonly known as “Baltimore painted furniture.”

Finlay often worked in partnership with his younger brother Hugh between 1803 and 1816, with additional shops at Frederick Street, 60 North Gay Street, and elsewhere. The first known advertisement for the Finlays' partnership was in the Baltimore *Federal Gazette*, on 25 January 1803, listing:



to any pattern, all kinds of  
FANCY and JAPPANED FURNITURE, viz.

Jappanned and gilt card, pier, tea, dressing, writing and shaving TABLES, with or without views adjacent to the city.  
Ditto cane seats, rush and windsor CHAIRS, with or without views.  
Ditto cane seats, rush and windsor SETTEES, with or without views.  
Ditto Window and Recess Seats.  
Ditto Wash and Candle Stands.  
Ditto Fire and Candle Screens.  
Ditto with views.  
Ditto Bedsteads and Bed and Window Cornices, & c.  
Which they warrant equal to any imported.

The Finlays' Classical collaborations began with their successful interpretation of contemporary artistic expression, as well as capable execution of period forms and iconography, which created dynamic partnerships between themselves, other artists, and patrons. The revival of interest in Classical design forms, inspired by archaeological enthusiasm for Greek and Roman antiquities and democratic models, and fueled by reaction against Rococo excess, began with a rectilinear, refined approach known as Neoclassical, moving from Italy to France and England, and thus to America.

By the turn of the century, a more in-depth study of Greek, Roman, and Egyptian furniture forms and household decorations led to designs that more correctly reflected the archaeological evidence promoted by contemporary scholars and designers. These forms assumed greater popularity as the United States emerged as an international power. Because these elements were more directly derivative, they were thought to reflect the ancient Classical and democratic ideals most meaningful to Americans.

The Classical forms were especially popular in Baltimore, which was experiencing phenomenal growth after the American Revolution, just as the fashion emerged. Baltimore, becoming the third busiest seaport in the United States, was a trading mecca, where imports and international designs could be compared and studied. Publications featuring the Classical designs of Robert Adam, George Hepplewhite, and Thomas Shearer, among others, became available in Baltimore libraries.

The Classical style quickly found popularity among the wealthy, whose collections of silver and furniture, whether local or imported, exhibited its influence. Early Neoclassical painted furniture was a prerogative of the wealthy, being comparable in cost to the best mahogany examples. The demand for this style was partially met by English and French imports to major United States ports, reinforcing the fashion. By February 1797, a "Fancy Chairmaker from London" was advertising in the *New-York Gazette and General Advertiser* "all sorts of dyed, jappanned, wangee and bamboo chairs, settees, etc. and every article in the fancy chair line" (Fales 1972:110). Thomas Jefferson introduced the style to the White House, and other examples can be documented up and down the East Coast of the United States. Nowhere in America, however, was it more widely adopted than by Baltimore's wealthy merchant class.

"Fancy" or painted and decorated furniture in the early Neoclassical style provided a light yet elegant alternative to the favored

mahogany with its rich, dark tones, particularly in drawing rooms. Thomas Sheraton extolled the beauty of decorated furniture, whether painted, gilded, or japanned. Not intended to conceal poor or mismatched woods or to be a country cousin to mahogany pieces, high style “chairs of this kind have an effect which far exceeds any conception we can have of them from an uncoloured engraving, or even of a coloured one” (Sheraton 1972:387; 192f., pl. 25). Quality, however, was a function of materials and the skill of the maker; Sheraton’s *Cabinet Dictionary* (1970:427) gave specific instructions for decoration and color, admonishing, “It is to be observed, that in every kind of colour, there is some of a bad, and others of a good quality. Several colours are adulterated, either to reduce the article to a cheap price, or basely to deceive the purchaser.”<sup>2</sup>

The Finlays were the right men in the right place at the right time. They appear to have taken almost immediate advantage of the elite’s desire for painted surfaces, whether on cornices, furniture, or carriages. With the extraordinary talent of their craftsmen, they positioned themselves to meet the demand for painted furniture and, by meeting it brilliantly, created even more of a demand.

The Finlays were in the forefront of the newest fashion. In 1809, the Finlay shop produced a *haute mode* suite of thirty-six chairs, two sofas, and four settees for the drawing room of James Madison’s White House, in the Classical Archaeological style. By 1810, in an effort to consolidate their leading position in the painted furniture genre, Hugh Finlay was abroad, selecting and forwarding “a number of Drawings, from furniture in the finest houses in Paris and London, which enable them [the Finlays] to make the most approved articles in their line,” according to the *Baltimore American and Commercial Daily Advertiser*, 19 December 1810 (Weidman 1993:99). For more than thirty years, Marylanders’ “intense and unceasing devotion to painted furniture” made Baltimore’s Classical Archaeological style furniture “a highly distinct, highly important group of American cabinetmaking” (Weidman 1993:91).

Indicating a growing business on the move, an advertisement in the *Baltimore American and Commercial Daily Advertiser*, 28 October 1813 (Weidman 1993), stated that their former manufactory near Gay and Frederick Streets was five floors, each 28 ft. × 30 ft. (8.53 m × 9.14 m). In 1811, they had five apprentices; all totaled, the Finlays employed eighteen apprentices between 1799 and 1823, split evenly as chair makers and chair, coach, and sign painters (Hill 1967:63). In the second decade of the nineteenth century, the Finlays employed more than sixty-five people.<sup>3</sup>

On 15 July 1816, the *Baltimore American* reported that “John Finlay having declined the Fancy Furniture Business—it will be continued by HUGH FINLEY & CO.” After 1816, when the Finlay partnership seems to have dissolved, John Finlay continued other businesses, including the proprietorship of the “Pavillion Baths” until at least 1841. City directories show him resuming chairmaking by 1827 and coachmaking by 1829. Upon Hugh Finlay’s death, however, John again assumed control of the fancy furniture factory, with the important Ridgely commission coming soon thereafter. By the 1850 census, John Finlay owned more than fifty thousand dollars in real estate.<sup>4</sup> He died in a steamboat accident in 1851 (Hill 1967:257). It is interesting to note that Finlay’s inventory, dated 17 June 1851, did not specifically indicate personal ownership of any painted furniture.

---

## The Clients

Perhaps not by accident, the Finlays' activity corresponded with Charles Carnan Ridgely's already developed interest in this fashionable artistic expression. A well-educated fashion setter and dynamic political leader, he became the second owner of Hampton in 1790 and made it a showplace, surrounded by formal terraced gardens, landscaped parkland, an orangery, and propagating houses. He was said to keep "the best table in America" (Parkinson 1805:vol. 1, 73).

During a trip to New York in the fall of 1797 (Carroll 1797), Ridgely purchased a set of "24 White Japan & Gold Chairs" at 26 shillings each, for a total of £31.4.0. A matching settee cost £1.8.0 (Ridgely 1797). William Palmer (1797), who sold the set to Ridgely, advertised himself as "Japanner/No. 106 Pearl Street." The chairs may have resembled in style and decoration a set of what Sheraton termed "drawing-room chairs."<sup>5</sup> The Ridgely set was one of the earliest introductions of this art to Baltimore. The liberal distribution of stylish painted furniture throughout Hampton included another set of fancy chairs purchased by Ridgely between 1795 and 1800. The original number of chairs is unknown; two of the set remain at Hampton and another was owned by a descendant in 1937.<sup>6</sup> Charles Carnan Ridgely, the wealthiest man ever to be governor of Maryland (three terms beginning in 1815), may have helped to precipitate an enduring fashion.

Purchases of painted furnishings, in both the Neoclassical and Classical Archaeological styles, continued throughout Charles Carnan Ridgely's tenure at Hampton. In 1814 alone, he paid John and Hugh Finlay over one thousand dollars, and John Finlay an additional \$106.52 (Dorsey 1814). Even the parlor of his elegant town house contained "1 Doz Green & Red chairs, 2 Green and red settees, 2 Green & gold pier tables, 2 Green & gold card tables, and 2 Green and gold lamp stands" (Baltimore City Court House 1832–33).

John Ridgely did not emulate his father's dynamic leadership qualities, but preferred instead the retired life of a country squire. On 28 January 1828, he married his second wife, Eliza Ridgely, whose influence on the interior and exterior of Hampton was profound. Eliza Ridgely was an only child, and wealthy in her own right. Very well educated—a student of French and Italian, as well as music and literature—Eliza traveled extensively, spending a considerable amount of time in France, Italy, and England. A devotee of European fashions, and friend and correspondent to the Marquis de Lafayette, she imported furnishings, paintings, and other decorative arts, and altered Hampton's gardens to the prevailing European mode.

Described by contemporaries as "fascinating," Eliza's trend-setting taste brought dramatic changes to Hampton. In addition to importing the latest furnishings and landscaping ideas, Eliza was inclined to purchase from the Finlays, as had her father. She and her husband would have selected the Finlay shop out of habit, but also because it purveyed the finest painted and gilded furnishings.

---

## The Objects

The suite of painted furniture ordered from Finlay in 1832 was intended for the drawing room at Hampton, and survives today in that same room. Recognized as "the greatest documented suite of all Baltimore late Neoclassical furniture" (Weidman 1993:109), befitting one of the grandest

Figure 3

Handwritten bill, John Finlay to John Ridgely Esquire, October 1832, itemizing the suite of painted furniture. Note: Eliza Ridgely paid the bill from her personal account. (Private collection.)

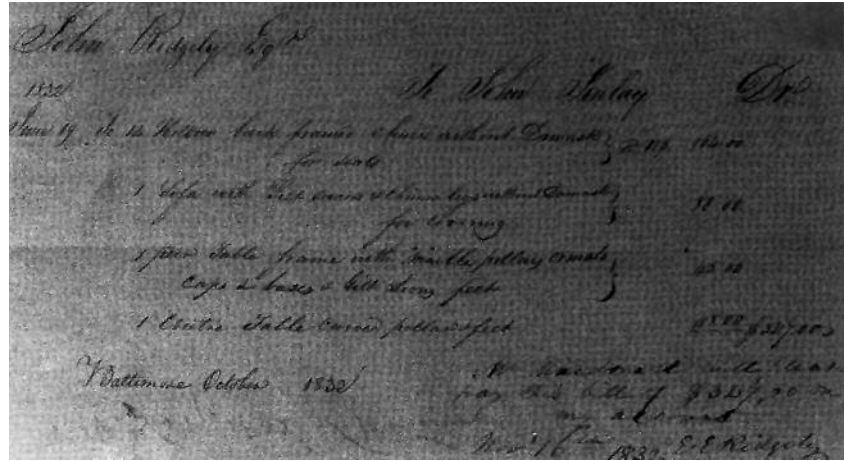

houses in America, much of the form and decoration of individual pieces is unique. The bill of sale for this suite of furniture (Fig. 3)<sup>7</sup> specifies:

- 14 Hollow back framed chairs without Damask for seats
- 1 Sofa with Gilt swans and chimn legs without Damask for Covering
- 1 pair Table frame with marble pillars ormallo caps & bases & Gilt Lions feet
- 1 Centre Table with carved pillar & feet

The cost for this suite was \$327, which excluded scagliola tops for the two tables.<sup>8</sup> The sofa alone, with its carved and gilded swans, cost \$80 without upholstery. The sofa was upholstered over a spring seat, another innovation; “patent spring seat sofas and chairs” of Boston origin were being sold in Baltimore by June 1828.<sup>9</sup> The upholstery was of crimson silk damask, which provided a richly contrasting counterpoint to the black and gold decoration. The fabric’s pattern can be seen in early house photographs. Thread fragments of this crimson hue were discovered during upholstery conservation carried out in 1993 by Mark J. Anderson, furniture conservator at the Henry Francis du Pont Winterthur Museum.

Eliza Ridgely’s cosmopolitan taste combined with the talent and working knowledge of John Finlay and his staff to form the first collaboration, resulting in the manufacture of this suite of furniture. Surpassing all other contemporary Baltimore examples, the sophisticated sofa exhibits a strong French influence, which we can attribute to Eliza Ridgely’s taste. A French silver wine ewer, embellished with swans and other Classical motifs found on the painted furniture, was a gift from the Marquis de Lafayette and may have been the impetus for the furniture’s decoration (Fig. 4). It is interesting to note that the carved and gilded swan arm supports on the sofa are derivative of those on Josephine’s couch at Malmaison, perhaps seen by Eliza during her European travels. The swan, considered “the bird of Venus” (Hope 1807:pl. 54),<sup>10</sup> was adopted by the Empress Josephine as her heraldic emblem. However, similar uses of swan motifs may have been adapted from well-known and repetitive design plates in such popular sources as Thomas Hope’s *Household Furniture and Interior Decoration* (1807), Pierre de la Mesangère’s *Collection des meubles et objets de goût* (1808:pl. 285), George Smith’s *A Collection of Designs* (1808:pl. 152), and various issues of Rudolph Ackermann’s *The Repository of Arts*, which would have been known to the Ridgelys and Finlays.



Figure 4

Detail of gilded stencilwork on splat of Finlay side chair shown in Figure 1, featuring swan and foliate decoration derivative of elements in contemporary design books. See, for example, plates 21 and 40 in Hope 1807.

The Finlay suite remained a feature of the most formal and important room at Hampton throughout five generations of family occupancy, with the exception of six chairs that traveled a half mile to the Hampton farmhouse in 1948, when the Ridgelys left the mansion (these were returned to Hampton's museum collection in 1980). When the Ridgelys left Hampton, they left the sofa behind. It was out of vogue and not comfortable for informal seating. Now, in a museum setting, the suite has resumed importance because it is still intact, in the setting for which it was made, and it is documented by an original bill of sale.

---

## The Preservation Challenges

Painted black, the Hampton suite displays gilded stencils that are given expression by exceptionally fluid black brushwork (Fig. 5). The suite also has, variously, carved and gilded paw feet, swan arms, and palmette or marble columns, scagliola tops, mirrors, and bronze *vernis* mounts. As with any piece representing this genre, the appearance of the decorative surfaces is critical to the interpretation of the object. Conservation treatment that recognized the importance of these surface coatings for future research and interpretation was vitally important.

Despite only limited use by the family, constant display since 1832 accelerated deterioration of many of the pieces. Benign neglect, as fortunes waned and staffing decreased, ironically assisted in preservation during Ridgely family occupancy; housekeeping was infrequent and lax. However, by 1972, when William Voss Elder mounted the landmark *Baltimore Painted Furniture, 1800–1840* exhibition, much of Baltimore's early painted furniture was too fragile to exhibit, and "too many pieces of furniture that were considered . . . were found to have been ruined by needless overpainting" (Elder 1972:16).

A lack of environmental controls also has affected the condition of the Hampton suite. Cold and damp in the winter have been counteracted by heat, supplied first by fireplaces and Franklin stoves, later by a wood/coal-burning "central heat" forced air system, and finally by radiators, introduced around 1910, which still operate today. There is no cooling or ventilating system. Humidity levels in the house during the winter fluctuate between about 10% and 20%, and can reach 100% in the summer.

Housekeeping practices have changed over time, with some cleaning "recipes" hurting rather than helping painted objects.<sup>11</sup> Paint is also vulnerable to chipping and peeling from mechanical damage; vacuum

Figure 5

Detail of foliate and anthemion decoration on the crest rail of HAMP 2890, one of the fourteen side chairs made by John Finlay (1777–1851) of maple, sweetgum, and white pine, with ebonized and gilt decoration. Significant losses to the black paint surround a much better preserved oil-gilded stencil with fine brushwork detail.

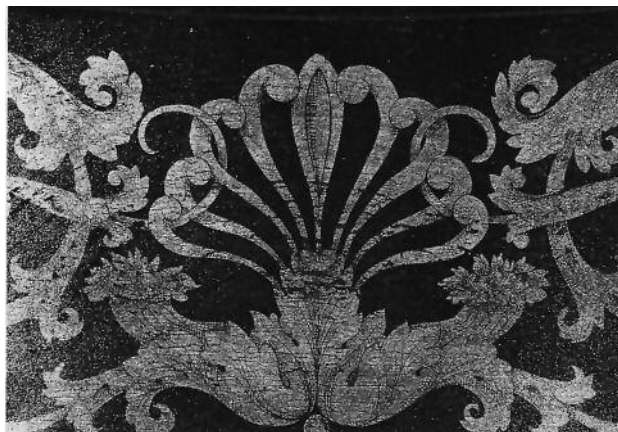

cleaners with attachments, feather dusters, and “elbow grease” have contributed their share of damage to the suite of furniture.

During the present curator’s first few months at Hampton in 1981—almost 150 years after manufacture of the Finlay suite—monitoring showed slow but active deterioration of surface decoration, including flaking paint and darkened gilded surfaces. Immediate efforts were made to obtain funding for conservation treatment, but monies were not available for several years. This delay proved, in one respect, to be fortuitous; in the intervening years, important information was gathered about conservation of painted wooden objects. Smaller projects served as study models for the curatorial staff at Hampton and provided the curator with questions that needed to be answered before embarking on the task of conserving the suite: What is the proper aesthetic for adequate preservation and interpretation of a painted object? When does one begin to lose sight of the original artist’s materials and intent? How much restoration is too much? When does conservation become restoration? And, finally, who dictates conservation—the artist, the conservator, the scientist, the curator, the interpreter, a trustee, or the director?

Reading and studying about both traditional and modern furniture construction, decorative techniques, upholstery methods, alternative cleaning systems, and environmental impacts has assisted in the analysis of the problem: a need exists for long-term preservation of a historically important suite of furniture with elaborately painted and gilded surface coatings—and with wood, marble, metal, and scagliola components—in the context of an unstable environment.

Academic research has provided historical perspectives and has helped to relate the Ridgely suite to other Finlay work now scattered throughout the country. Recognition and appreciation of the suite’s place in history—as a complete set of furniture designed by John Finlay and associates, drawn from European and Classical sources, and influenced by Ridgely preferences—helped secure funding for the latest collaborations to preserve this significant furniture group. The intrinsic and artistic importance of the suite helped to justify the cost of conservation treatment.

By 1987, it was apparent that the deterioration of the furniture was accelerating. Monitoring steps were taken, such as placing white paper under some of the pieces to check for flaking paint. The curator soon realized that the projected cost of having different firms prepare written treatment proposals and quotations would consume most of the conservation budget. Still somewhat tentative about the different treatment options available and various treatment approaches suggested, Hampton’s curator contacted Donald L. Fennimore at Winterthur to discuss these concerns, particularly in light of the advances by Richard L. Wolbers and other scientists on cleaning painted surfaces.<sup>12</sup> The enthusiastic support of curator Don Fennimore during these difficult deliberations led to conversations with the Winterthur Museum team of experts, led by Gregory J. Landrey, furniture conservator.

Related by design to several pieces in the Winterthur collection, the documented Finlay suite at Hampton was mainly unrestored and provided a rare opportunity for complete study and analysis of original decoration and surface coatings. Hampton’s curator and Winterthur’s conservators developed a collaborative agreement: a team of Winterthur conservators and students would prepare the treatment proposal for the

Finlay suite, in return for retention of the findings for Winterthur's educational and research programs.

This teamwork provided Hampton with authoritative analysis and the friendly, dedicated support of Landrey; Anderson; Wendy H. Samet, paintings conservator; and others. Scientists Wolbers, Harry Alden, and Janice Carlson also contributed to the analysis. Each piece was examined by conservators with expertise in wood, surface coatings, and upholstery conservation to determine treatment procedure and cost, and to collect samples of surface coatings for microscopic analysis.

Hampton's curator and the Winterthur team had agreed from the beginning, however, that the Winterthur staff did not have time to carry out the conservation treatment; but they did agree to serve as consultants on the conservation process. Three factors created the context within which treatment would take place: (1) funds for this project were limited, and both curator and conservator were going to have to work together to "stretch" treatment dollars; (2) the curator did not want the final result to look overrestored; but (3) the curator made it clear that even though it was not her primary concern, the furniture had to look better after treatment. Curators often have to justify conservation work to their funding sources and their audience, and a better visual appearance provides helpful support. The curator also wanted the appearance to evoke pride in both patron and maker, providing a focal point for Hampton's and Baltimore's place in American furniture history. In short, we had to make the suite look better within the parameters of a safe and cost-effective treatment.

Deborah Bigelow Associates joined forces with Winterthur Museum conservation staff to prepare an acceptable treatment strategy. A grant from Preservation Maryland, through Historic Hampton, Inc., enabled the project to proceed. A precontract visit by the curator to the conservators' studio forged a mutual trust and confidence. With an innate understanding of the suite's historic significance and its physical fragility, the authors set to work on it piece by piece, beginning with a chair and working up to the great sofa. A second grant from Preservation Maryland enabled the authors to complete treatment of the suite, plus two side tables and two Grecian couches, also made by the Finlays for Hampton—all of which are exhibited in the drawing room.

One of the challenges of treating this suite of painted furniture was to keep the cost reasonable. There were considerable losses to most of the painted surfaces, and, with painting conservation as the model, the authors quickly realized that a meticulous approach to replacing the losses would require many hundred hours and add as much as ten thousand dollars to the cost of treatment for each object. As neither market value nor available funds permitted this methodology, a quicker approach was needed to achieve a stable and visually pleasing final result.

In deciding what to do, the conservation team was aided by two fortunate circumstances. First, most of the gilded stencils were in good condition, and others—although in poorer condition—still provided design definition. Second, there were few previous repairs to the surface coatings, which is a rare and very favorable situation for the conservator.

The conservators were thus able to settle upon a minimal treatment approach to stabilize the structure and surface coatings, remove unwanted previous restoration, limit inpainting and ingilding, and add a final coat of wax. Focusing on stabilization, they saved as much as possible

of the original materials; accepted signs of use (not abuse) as an inevitable, and even welcome, part of the object's history; and introduced a level of visual improvement that was pleasing to all concerned.

Given all the factors, this course of action proved that a minimal treatment can sometimes be a viable option when problems are great and funds are limited.

---

## Examination

The most serious problem on each of the twenty-one pieces of furniture was the friable condition of the paint. Scores of black specks on the floor or on the conservator's fingertips at the gentlest touch, were clear evidence that the paint was crumbling from the surface before one's eyes. Because the paint loss did not correspond with patterns of use, and because the oil-gilded stencils were preserved, while adjacent areas of black paint were completely missing, it was hypothesized that the oil paint was originally mixed with too little binder. It was further surmised that the gilder's application of oil size over the black paint in the process of stenciling had coincidentally added binder into the minimally bound paint. Over time, this process actually saved the gilded stencils, which are the masterpieces of this suite of furniture.

The suite's painted and gilded surface was original; but black over-paint, the remains of old glue, and bronze powder paint marred the original paint in areas where structural repairs had been made, along the stile or at the join of the seat rail with the stile. While the oil-gilded carved elements initially looked to be in fairly good condition, we later realized that they had been regilded. Information provided by ultraviolet light microscopy and X-ray fluorescence analysis confirmed our visual analysis of the suite's painted surface, and our treatment proposal was based on this microscopic information, as well as on our observations and solvent tests.

Paint samples from the chairs served as a model for the suite. The original materials on the chairs fell into two categories: (1) ground preparation and paint layers, and (2) painted and gilded design layers (Table 1). The wood had been primed with a coarse gray oil paint, followed by two layers of black oil paint, and protected with two layers of oil-free varnish. Gold leaf was attached with an oil varnish, and black linework was distinctly visible on top of the gilding. The entire decorative surface was then

*Table 1* Analysis of black paint with gilded stencils from one of the suite's chairs, displaying two areas of original material

Original design layers (painted/gilded)	
Layer 6	varnish (toner)
Layer 5	black paint (design line work)
Layer 4	gold leaf
Layer 3a, b, c	varnish (size)
Original ground preparation and paint	
Layer 2a, b	black paint
Layer 1	gray paint ground



protected or toned with a natural oil-free varnish. Striping on the chairs was gilded on the front and painted on the back.

Based on the information in Table 1, the surface was tested for sensitivity to water by rubbing a distilled water swab on a painted edge worn through to the wood. Since none of the layers reacted with or dissolved in water, a water-based adhesive was chosen to stabilize the paint layers.

The carved and oil-gilded wood also presented a difficult conservation problem because these surfaces had been cleverly regilded with matte gold leaf (Table 2). The authors were eager to remove it and restore the brilliant original gilding. Examination of a cross section of one surface coating (Fig. 6) indicated that the bare wood was brushed with coarse-particulate, yellow oil paint, which could be seen penetrating the wood vessels, and then with a much finer consistency of the same color paint. Finely ground oil varnish with the appearance of brown sugar had been applied next over the ground preparation as a size for the gold leaf. The size had bled into the ground coat and settled out upon drying, with finer particulate on top of coarser; but, most likely, it was applied as one coat of size. Gold leaf was applied on tacky varnish size and protected with shellac varnish, which imparted a warm, translucent appearance to the original leaf.

*Table 2* Analysis of sample of carved and oil-gilded wood from the sofa's swan arms displaying two areas of original and one area of restoration surface coatings

Restoration oil gilding	
Layer 7	varnish (toner)
Layer 6	metal leaf (gold/22k)
Original oil gilding	
Layer 5	varnish (toner)
Layer 4	metal leaf (gold/22k)
Layer 3	varnish (size)
Original ground preparation	
Layer 2b	yellow ground coat (fine)
Layer 2a	yellow ground coat (coarse)
Layer 1	wood

*Figure 6*

Cross section of gilded surface coatings on carved and gilded swan of the sofa in Figure 1, HAMP 1160. The sample indicates that the previous restoration metal leaf was applied directly on top of the original gilding layers. The sample also included part of the wood substrate.

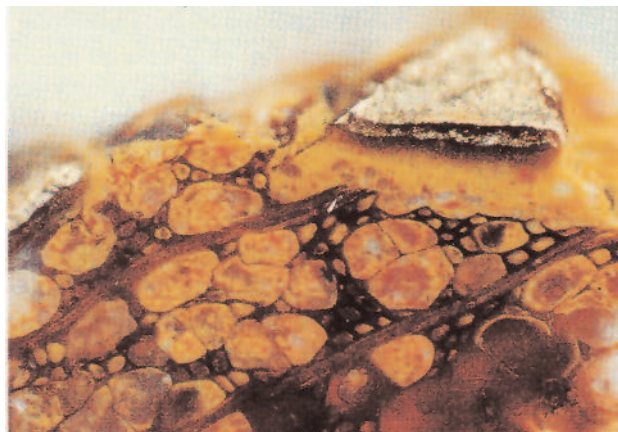

Following X-ray fluorescence analysis,<sup>13</sup> which proved that the restoration gold physically matched the original, it became apparent that the restoration leaf had been applied by brushing solvent on the original shellac toner, laying the gold quickly onto the now sticky shellac, and (when dry) brushing a thin, transparent oil coating over it for protection. On the underside of the swans, a Milky Way pattern of gold particles extending beyond the desired boundary indicated the sloppy application procedure. Working directly on the old, dirty surface, and with little control over drying time, the restorer's results were now dull and coarse to the touch. Solvent tests proved that it would be difficult to remove the overgilding without removing the original shellac. Unwilling to risk this loss, the conservators elected to retain the existing oil gilding from this old restoration and clean it to a more pleasing appearance.

While the provenance of the suite was not in question, the wood was identified to provide more information about the makers' construction decisions. Two chairs were sampled in four areas, and four woods were identified: soft maple, sweetgum, and black gum on the painted units; and white pine on the seat.

---

## Treatment

Conservation treatment spanned a two-year period between July 1989 and August 1991, progressing from groups of three, seven, and four chairs to the center table, pier table, and sofa. Hours spent conserving objects with the same surface coatings fostered a familiarity with the works that resulted in occasional adjustments to the basic treatment (described in detail in the Notes). Decision making was shared between conservator and curator. Technical problems that altered the outcome of the treatment, and thus the object's appearance, were presented to the curator for her decision; technical adjustments within a successful treatment were made in-house by the conservators.

### Stabilization and cleaning

Visual and technical concerns directed the search for the best consolidant. The final surface had to look natural, without the high shine imparted by acrylic resin consolidants. Since introducing a consolidant to stabilize the paint layers would be irreversible, it was important to choose a consolidant that would not interfere with future treatments of the suite. Gelatin answered both these requirements. Soluble in water and relatively color-free, it would not stain or otherwise harm the oil-paint layers. It would be readily absorbed by the underlying wood, thus it would not hinder future treatment (Fig. 7). Excess on the surface could be cleaned without harm, and the final appearance would have a natural sheen. Local cleaning problems were handled on an ad hoc basis.<sup>14</sup>

### Restoration

Because the suite's prerestoration appearance was a remarkably accurate reflection of the makers' intent, for ethical and financial reasons the conservators decided to add as little of their own restoration as possible. Losses were inpainted to continue straight lines or outline stencil designs only on the most visually disturbing areas.

Figure 7

Front seat rail of sofa, HAMP 1160, during conservation to stabilize painted and gilded surface coatings. Gelatin adhesive is applied through small pieces of facing tissue.



Inpainting was carried out using water-based media, which are easy to apply, distinguish, and remove from the original materials and are visually compatible with the existing surface sheen. Using water-based materials also allowed for the application of a final protective coat of wax without dissolving the inpainting or removing it during the buff-out phase of waxing.<sup>15</sup> Wax was used, rather than a synthetic resin, as a final protective coating because it offers good protection from moisture, is easy to care for, and lends a natural and pleasing final appearance to the furniture (see Materials and Suppliers).

This treatment discussion has been limited to the care given the painted and gilded surface coatings. But there were other materials that needed to be treated, as well; and a pleasing final appearance on each piece of furniture depended on the successful treatment of each of its parts. While the chairs and sofa had upholstery, the card table and pier table included metal, marble, and stone components in their assembly, and there was a need for visual compatibility among the elements (Fig. 8). Overshadowed by brightly polished metal mounts, or bleached-white marble columns, an old paint surface looks weary instead of mellow, and the viewer's eye—distracted by the glitter of new surfaces—struggles unsuccessfully to bring the object into focus. The conservation team was determined that this would not be the final appearance of the Hampton suite; in this regard, the treatment was highly successful.

All of this teamwork allowed the conservators to realize their goal: a well-documented preservation treatment that stabilized original materials and left the integrity of Finlay's finishes well protected for interpretation. Working with glue and wax, the conservators hoped to prolong the furniture's life well into the future, envisioning no more danger than the touch of a thoughtless visitor or the humidity of Baltimore's summers. Imagine their astonishment when, in November 1992, a dust explosion created during a construction project engulfed the Mansion's interior. The dust, a mixture of grit and powdery sand, settled over everything. Immediate analysis by Meg Craft and Sian Jones of ACTS, Inc., verified by the National Park Service's Division of Conservation, showed the dust to have a pH level of  $\pm 12$ . Seven months and five full-time cleanup people later, one happy discovery was made: the stabilization and wax coating of the Finlay suite had preserved its surfaces intact.



Figure 8

Pier table, John Finlay for John and Eliza Ridgely of Hampton, 1832. H:94; W:106.8; D:45.7 cm. This extraordinary object illustrates the mixed media that had to be considered during the conservation process, including ebonized and gilded wood, mirrored glass, marble columns, bronze *verniss* mounts, and an imported scagliola top (HAMP 1167).

Conservation is critical to interpretation, and to the preservation and intrinsic value of this suite. As a safeguard, several pieces of painted furniture from Hampton's collection reside at another location, in climate-controlled security with up-to-date fire suppression equipment. This is as close as a conservator or curator will get to keeping the set in a dark and protected place.

---

## Conclusion

The conservators' spirit of camaraderie and patient nurturing of the curator's technical education during the three years of conservation, coupled with the curator's intense academic interest and decision-making authority in the treatment process, epitomized the ideal working collaboration. There was always a committed team effort to control the degradation and minimize the impact of climatic elements by protecting the surface decorations. During the multiyear process, the professional circle was regularly enlarged to include consultation with Winterthur staff and other colleagues. Curators, including Wendy Cooper, who used the Finlay sofa as a focal point in the influential *Classical Taste in America, 1800–1840* exhibition,<sup>16</sup> and Gregory Weidman, a leading authority on the Finlays' work, enhanced the conservation perspective. Mark Anderson designed noninvasive upholstery techniques for the sofa and one chair and worked with an independent upholsterer to achieve laudable results. The suite, which originally sold in 1832 for \$327 and was purchased in 1948 for the National Park Service at less than \$1,500, was preserved at a cost many times that amount. However, this cost was modest in relation to the importance of the objects and their final, stable appearance. The value of this set both to Hampton and to general scholarship is incalculable.

Hampton is a national park, open seven days a week, beset by fluctuating temperatures, immoderate winter dryness, and stifling summer humidity. Light, dust, pollution, and human interaction also contribute to the concern for these objects; the goal has been to minimize the impact of all these factors. The hope is that the current conservation work will be almost invisible fifty years from now, during the suite's bicentennial, and that it will have provided maximum benefit with minimum detriment to the next collaboration in this Classical story.

---

## Notes

- 1 The authors are grateful to William Voss Elder III and Gregory R. Weidman for many of the references about the Finlays. For additional information, see Elder 1972, Weidman 1984, and Weidman 1993.
- 2 A full discussion of colors and techniques may be found in Sheraton (1970:422–28).
- 3 From the 1820 Census of Manufactures. See Weidman (1984:75) for a breakdown of these workers.
- 4 Baltimore, Maryland; 10th Ward, 076.
- 5 For example, no. 60.331 at Winterthur, made in Philadelphia ca. 1800; shown in Montgomery (1966:pl. 92). See also Chris Shelton's chapter herein.
- 6 Chair no. 278, as seen in Miller (1937:vol. 1, 205).
- 7 Bill is owned privately; archival copy retained in the research files, Hampton National Historical Society.
- 8 The tabletops were imported from Italy, decorated in scagliola with polychromed landscape scenes and ornate oak leaf borders, in the manner of Claude-Joseph Vernet.

9 From the 5 June 1828 edition of the *Baltimore American*, as quoted in Weidman 1984.

10 See also plates 21 and 40(2), in Hope 1807. For an excellent, detailed discussion of swan symbolism and its links to both Apollo and Venus, see Cooper (1993:144–49).

11 The accumulation of dirt on fine furniture has been a housekeeping concern for centuries. Catherine E. Beecher, in *A Treatise on Domestic Economy* (1841:343–44), suggests removing it by rubbing on sweet oil and then wiping it off “thoroughly with a silk or linen rag,” or by rubbing in linseed oil, or by applying a mixture of “beeswax in spirits of turpentine, adding a little rosin. Apply with a sponge, and wipe off with a linen rag.” Thomas Sheraton’s *Cabinet Dictionary* (1970:290) suggests “a ball of wax and a brush.” Often these applications actually attracted additional dirt. Robert Roberts, in his 1827 *House Servant’s Directory*, discusses japanned articles, directing that one “take a sponge and dip it in warm water, rub on a little soap, and wash . . . with this; wipe it dry, and if it looks smeary, dust a little flour over it, and polish off with a dry cloth” (Roberts 1977). Modern recipes and commercial products may also be detrimental.

12 See, for example, Wolbers and Landrey 1987 and Wolbers 1990.

13 Janice H. Carlson, a senior scientist at the Winterthur Museum, examined one carved and oil-gilded paw foot from the sofa to determine metal composition of the gold leaf. She also compared the original with the restoration leaf, performing qualitative energy-dispersive X-ray fluorescence analysis, using several different systems (Cd-109 source, Am-241 source, Ag secondary target, and Gd secondary target). She found that both original and restoration gold leaf had concentrations of gold and silver similar to a 22k reference standard, 79.22.3 (91.7% Au, 4.1% Cu, and 4.1% Ag).

14 Warm gelatin (5% in distilled water) was brushed onto small sections of paint and covered with facing tissue, placed smooth side down. Saturated with gelatin, the tissue paper was then pressed flat using a cool tacking iron and silicone-coated polyester film. Twenty-four hours later, the dry glue-hardened tissue and the excess gelatin were removed using distilled water at room temperature.

After stabilization, color was restored on small areas of blanched varnish with a solvent blend of ethanol, acetone, dimethylformamide, and Cellosolve (1:1:1:7), applied sparingly by brush.

Local cleaning problems were treated, as needed, with benzine emulsion, xylene gel, or acetone gel, and a water-based “stock” gel. Small areas of very dark varnish were gradually reduced to the desired appearance with ethanol or acetone swabs, Triton X100 (10% in xylene), or 1-methyl-2-pyrrolidinone (25% in mineral spirits).

The formulations are as follows:

Benzine emulsion: distilled water (20 ml), benzine (50 ml), and enough Triton X100 to make a stable emulsion

Xylene gel: xylene (200 ml), distilled water (4 ml), Ethomeen C12 (30 ml), and Carbopol 954 (4 g)

Acetone gel: acetone (200 ml), distilled water (200 ml), Ethomeen C25 (20 ml), and Carbopol 954 (6 g)

“Stock” water-based gel: Tris/Tris-HCl buffer reagent, pH 8.4 (0.664 g); hydroxypropylmethyl cellulose (1.5 g); Triton X100 (0.1 g), and distilled water (100 g)

15 Raw wood was sealed with a blend of equal amounts of glossy and matte Soluvar varnish. Winsor and Newton gouache and watercolor paints, mixed with gum arabic and Kodak Photo-flo 200 solution, were applied, allowed to dry, and buffed to a sheen compatible with the final appearance.

Before ingilding, areas were isolated with the same Soluvar varnish mixture and sized with three-hour oil size, or twelve-hour oil size when a more durable surface was needed to withstand the patination process. Twenty-two karat gold powder and gold leaf were used for small and large repairs, respectively. Gold powder repairs were toned with watercolors and gouache colors mixed with small amounts of 22 karat gold powder, gum arabic, and Photo-flo 200 solution. The dry surface was then polished with surgical cotton. Gold leaf repairs were patinated with matte varnish to dull the surface and were toned by alternating layers of watercolors, Soluvar varnish colored with Maimeri Restoration Colors, and 22 karat gold powder.

The varnish was a blend of glossy and matte—2:1 for a shinier appearance or 1:2 for a duller appearance. Linework was replicated with Higgins nonwaterproof black India ink.

Renaissance Wax was applied to each piece of furniture by hand and buffed with a soft flannel cloth.

16 For an in-depth discussion related to the Finlay suite, see Cooper 1993.

---

## Materials and Suppliers

**August Ruhl 22 karat gold leaf and powder**, Sepp Leaf Products, 381 Park Avenue South, Suite 1312, New York, NY 10016.

**Carbopol 954**, B. F. Goodrich, Research and Development, 9921 Brecksville Road, Cleveland, OH 44101.

**Cellosolve**, Fisher Scientific Co., P.O. Box 12405, St. Louis, MO 63132.

**Ethomeen C12 and C25**, Conservation Materials Ltd., 100 Standing Rock Circle, Reno, NV 89511.

**Gelatin glue size**, Sepp Leaf Products.

**Higgins nonwaterproof drawing ink**, Pearl Paint Co., 308 Canal St., New York, NY 10013.

**Hydroxypropylmethylcellulose**, Sigma Chemical Co., P.O. Box 14508, St. Louis, MO 63178.

**Kodak Photo-flo 200 solution (CAT 146 4502)**, Eastman Kodak Company, 1205 Scottsville Rd., Rochester, NY 14650.

**LeFranc 3-hour and 12-hour gilding size**, Sepp Leaf Products.

**Maimeri Restoration Colors**, Conservation Materials Ltd.

**Maypon 4C**, Inolex Chemical Company, Swanson and Jackson Streets, Philadelphia, PA 19148.

**Renaissance Wax**, Conservation Materials Ltd.

**Solubar varnish**, Conservation Materials Ltd.

**Trizma-8.4 (Tris/Tris-HCl buffer reagent, pH 8.4)**, Sigma Chemical Co.

**Triton X100**, Sigma Chemical Co.

**Winsor and Newton watercolors and gouache paints**, Pearl Paint Co.

---

## References

- Baltimore City Court House  
1832–33 “Account Sales of the Personal Estate Sale of Charles Ridgely of Hampton Deceased, Which Was Sold at Public Sale . . . Oct 1, 1829 for Cash Late Residence North Gay Street. Baltimore.” Liber D.M.P. No. 14. Photocopy and transcribed copies in the research files of the Museum Services Division, Hampton National Historic Site.
- Beecher, Catherine E.  
1841 *A Treatise on Domestic Economy*. Boston: March, Capen, Lyon, and Webb.
- Carroll, Charles  
1797 Letter to his son, Charles Carroll Jr., in New York City, 13 September. Letter No. 1, MS. 203, Maryland Historical Society.
- Cooper, Wendy  
1993 *Classical Taste In America (1800–1840)*. New York: Baltimore Museum of Art and Abbeville Press.
- de la Mesangère, Pierre  
1808 *Collection des meubles et objets de goût*. Paris.
- Dorsey, Allen  
1814 Allen Dorsey Accounts, 14 January, 11 February, and 13 December. G. Howard White Collection, Hall of Records, Maryland State Archives.

- Elder, William Voss III  
1972 *Baltimore Painted Furniture, 1800–1840*. Baltimore: Baltimore Museum of Art.
- Fales, Dean A., Jr.  
1972 *American Painted Furniture, 1660–1880*. New York: E. P. Dutton.
- Hill, John Henry  
1967 The furniture craftsman in Baltimore, 1783–1823. Master's thesis, University of Delaware.
- Hope, Thomas  
1807 *Household Furniture and Interior Decoration*. London: Longman, Hurst, Rees, and Orme.
- Miller, Edgar  
1937 *American Antique Furniture*. 2 vols. New York: M. Barrows.
- Montgomery, Charles F.  
1966 *American Furniture: The Federal Period*. New York: Viking.
- Palmer, William  
1797 Letter to General Charles Ridgely, 10 October, Ridgely Family Papers, Maryland Historical Society.
- Parkinson, Richard  
1805 *A Tour in America in 1798, 1799, and 1800*. 2 vols. London: n.p.
- Ridgely, Charles Carnan  
1797 Box 6, MS. 692.1, Ridgely Papers, Maryland Historical Society.
- Roberts, Robert  
1977 *House Servant's Directory*. Boston: Munroe and Francis, 1827. Reprint, Waltham, Mass.: Gore Place Society.
- Sheraton, Thomas  
1970 *Cabinet Dictionary*. 1803. Reprint, New York: Praeger Publishers.  
1972 *The Cabinet-Maker and Upholsterer's Drawing-Book*. 1793–1802. Reprint, New York: Dover Publications.
- Smith, George  
1808 *A Collection of Designs*. London.
- Weidman, Gregory R.  
1984 *Furniture in Maryland, 1740–1940*. Baltimore: Maryland Historical Society.  
1993 The furniture of classical Maryland, 1815–1845. In *Classical Maryland, 1815–1845*. Baltimore: Maryland Historical Society.
- Wolbers, R. L.  
1990 Notes for workshop on new methods in the cleaning of paintings and wooden artifacts, Getty Conservation Institute, Los Angeles. Typescript.
- Wolbers, R., and G. Landrey  
1987 The use of direct reactive fluorescent dyes for the characterization of binding media in cross-sectional examinations. In *AIC Preprints, 15th Annual Meeting*, 168–202. Washington, D.C.: American Institute for Conservation of Artistic and Historic Works.

# Applied Aesthetics: Restoring the Original Cornice Decoration at Olana

Deborah S. Gordon

**D**URING THE MID-NINETEENTH CENTURY, the artist Frederic Edwin Church (1825–1900) was celebrated as the outstanding landscape painter of his day. As the popularity of his Romantic style waned and his health deteriorated, he increasingly turned his attention and his artistic energies to the creation of his estate, which he called Olana, located on the Hudson River just south of Hudson, New York. Although Church had the help of an architect, Calvert Vaux, in preparing drawings for his new house, it appears that Church made most of the aesthetic decisions, while Vaux engineered the structure. A rendering by Vaux (Fig. 1) dated 28 May 1870, resembles the home only in its fanciful medievalism. During a trip to Europe and the Middle East in the late 1860s, Church developed an admiration for Islamic domestic architecture, and this had a profound influence on both the spatial organization and the decoration of Olana. Church's direct involvement in every aesthetic choice is evident in his three hundred to four hundred architectural sketches that have survived in the site's archives.

The exterior of the home is stone combined with elaborately patterned brickwork, further enlivened with polychromed tiles and Gothic

Figure 1  
Calvert Vaux, *Study of a House for F. E. Church Esq're at Hudson N.Y.* Pencil, H:25.4 cm, W:34.3 cm. New York State Office of Parks, Recreation and Historic Preservation, Olana State Historic Site, Hudson, N.Y. (OL.1982.1107)





*Figure 2*

James Harvey Van Gelder, photograph of the east elevation of Olana, ca. 1900. Vedder Memorial Library, Greene County Historical Society, Coxsackie, N.Y.

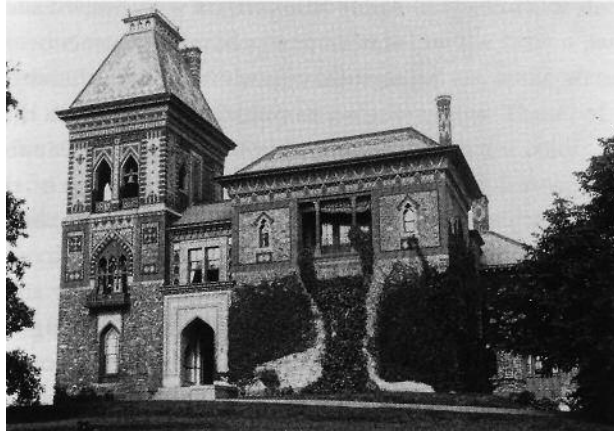

woodwork. To crown this collage, the irregularly massed structure had five separate wooden cornices, each painted and gilded in different patterns and colors (Fig. 2).

Construction on the house began in late 1870; the work, including the decoration, continued at least through 1876. Olana remained in the Church family until its acquisition by New York State in 1966. Since then, there has rarely ceased to be some type of restoration activity going on at Olana in an effort to return the house and grounds to their appearance during the last decade of Frederic Church's life. Several years ago, the New York State Bureau of Historic Sites (BHS) decided to turn its attention to one of the most significant as-yet-unrestored features of the building: its cornices. The decoration, originally accomplished roughly between 1872 and 1876, was maintained over the years until 1955, when Church's daughter-in-law was advised by the caretaker of the estate to paint the cornices a solid color, rather than incur the expense of restenciling.

The decision to restore the cornices was easy; the degree of weathering they had sustained suggested that if something was not done quickly, significant portions of the evidence would be lost. Roughly 20% of the original paint was already lost, and the remainder was in fair to poor condition. The decision to repaint (rather than remove the overpaint to reveal the original stenciling) was made—as many decisions concerning architectural paints are—for practical as well as aesthetic reasons. Exterior paint films, however decorative, are generally considered sacrificial. When subjected to the effects of weathering, a paint film will gradually deteriorate until it can no longer meet its protective or aesthetic function. Even if it were physically possible and financially feasible to reveal the original decoration, a weak and discolored paint film would be exposed.

The decision as to how to restore the cornices was considerably more involved. An interdisciplinary group consisting of site staff, BHS building conservation staff, and management met to discuss options.

---

## Research Methodology

The first need was to identify who would do the research. Because the state's conservation staff was already committed to other projects, the option of contracting with an outside architectural conservator was considered. This would have been expensive but would have had the advantage of getting the research done in one major effort, something that can

rarely be managed with limited site staff. In the end, however, the decision was made to phase the project over several years and to use the BHS architectural conservation staff, thereby capitalizing on the considerable expertise on painted finishes at Olana that has been developed over the years.

Next various possible approaches to accomplishing the research were considered. The position of the cornices—6–15 m above the ground—and the condition of their painted surfaces suggested that it would be virtually impossible to identify the stencil patterns and colors by sampling in the traditional way and examining the samples under a microscope in a lab. A more promising way to proceed seemed to be in situ examination with a field microscope, which would allow the researchers to locate and outline boundaries between fields of color. This also proved unworkable, however, for a variety of reasons. The paint films, particularly the stenciled elements, were so thin and worn that the field microscopes were simply not powerful enough to distinguish between successive layers of paint. Furthermore, the unfavorable physical conditions—the slightly swaying scaffold, inadequate light, working above one’s head, and so on—precluded the most thorough examination. The most satisfactory solution seemed to be to remove one large section of each cornice (containing one full repeat) and take them to the laboratory, where they could be put under the microscope for examination, inch by inch, if necessary.

---

## Conservation of Existing Evidence

The other serious problem was how to preserve the existing paint and at the same time provide a sound and reasonably smooth substrate on which to reproduce the overpainted stenciling. About 30% of the existing paint required consolidation before it could be painted over. Sanding to achieve a smooth surface was undesirable because important paint evidence would be lost in the process. Some kind of filler would have been needed to smooth over the alligatored surface, and a filler has not been found that performs satisfactorily in an exterior location. Furthermore, although an isolating layer is used in conservation practice to ensure reversibility before overpaint is applied to an original surface, it was felt that an isolating layer in an exterior location would act as a moisture barrier and very likely result in more damage than protection by preventing the materials from “breathing.” It seemed that the most secure way of preserving original paint was to remove representative sections of each cornice and keep them in a protected environment. This would permit the preparation of each cornice for repainting (in the same way that other exterior woodwork would be prepared) when the time came to restore the cornice decoration.

Because this approach met both research and conservation needs, sections measuring 1.22–1.83 m (4–6 ft.), from each of the five cornices, were removed and replaced with new wood, which was painted with the same brown paint found elsewhere on the cornices. The removed pieces were reassembled in their original configurations on specially fabricated skeletal frames and were stored in the attic of the house, along with other historic collections.

---

## Archival Evidence

Before discussing the examination of the paint on the cornices, it is important to mention that there were other avenues of research available. The collection at Olana contains many of Church’s sketches for the cornice decoration, many in oil or watercolor. These can be attributed to one cor-

nice or another, based on the shape of the cornice itself and on “ghosts” of the original decoration visible below the brown paint. The archive also contains dozens of the stencils themselves; some were used for the original decoration, some for later restenciling. These, of course, offer the clearest information about patterns and paint colors. The archive also contains pounce patterns (full-scale perforated drawings used for transferring some of the larger or more complicated designs to the cornices), where the designs were painted in by hand.

There are also references to the decoration and maintenance of the house in surviving correspondence between Church and various family members and friends. Although most of these references are somewhat vague, they do give a sense of the pace at which these activities were accomplished, and of Church’s attitudes. For example, in a letter to Martin Johnson Heade dated 22 September 1885, Church wrote:

I undertook to make thorough repairs of my House—nothing of importance in that way having been done since it was built 13 years ago—also some additions and the completion of unfinished parts. . . . I dare not leave home for a day because the workmen call upon me hourly for special directions—I have to superintend the mixing of tints for the painters and make working drawings for the carpenters—&c—

A year later (20 June 1886), Church wrote to his friend Erastus Dow Palmer: “I have a painter at work going over the worn places on the exterior of the House and expect to commence on interior decoration to morrow.”

For a researcher, the archive is a rich source of primary materials, but it is incomplete. Some cornices are amply documented with sketches, stencils, and pounce patterns; some have very little. Even if the record were more complete, the archival evidence is insufficient. Church’s sketches, while they have proved to be invaluable for deciphering certain of the more elusive aspects of the physical evidence, still are only sketches and do not necessarily represent the finished product accurately (Fig. 3). Research on two cornices has shown small variations in design and placement of elements, and some alterations in palette between the sketches and the final work. For one of the as-yet-unresearched cornices, there are several sketches, which show roughly the same patterns but very different color schemes.

Some research had already been done on the stencil collection, which had a direct impact on the work. A report by Van Dolsen (1983)

*Figure 3*

Frederic E. Church, oil sketch for stencil decoration of the stairhall cornice. New York State Office of Parks, Recreation and Historic Preservation, Olana State Historic Site. (OL.1982.753)



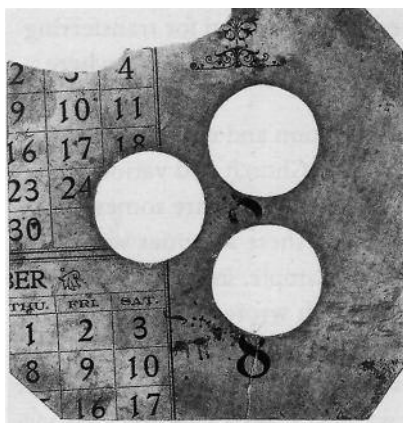

Figure 4  
Stencil cut from a calendar. New York State  
Office of Parks, Recreation and Historic  
Preservation, Olana State Historic Site.  
(OL.1982.1299)

suggests that the cornices were first decorated in the mid-1870s, then restenciled by Frederic Church in the late 1880s. (In keeping with the general policy for interpretation and restoration at the site, which focuses on the last decade of the nineteenth century, this later stenciling would be restored.) Identification of a second stenciling was based on the discovery in the collection of a stencil that the author noticed had been cut from a calendar (Fig. 4). The vertically arranged numbers at the right were interpreted as indicating that the calendar was from the year 1888. This provided evidence that the cornices were probably repainted around this time.

One interesting and humbling aspect of doing this type of research is the realization that the same evidence can support very different conclusions. As part of this project, the previous research was reexamined. A closer look at the stencil cut from a calendar and a consultation with a perpetual calendar<sup>1</sup> showed that the interpretation of this as an 1888 calendar was inaccurate. Because of the particular arrangements of days and months, it could not be from 1888. In addition, evidence was found in Church's correspondence, noted earlier, suggesting that his approach to maintenance was rather sporadic, that he touched things up only when and where he perceived the need. Consequently, it seemed unlikely that the cornices were systematically restenciled, top to bottom, in a single effort.

The report also stated that the stencils could be divided into two groups based on the weight of the paper from which they were cut. Although there is a great deal of variety in the papers used, suggesting that the stencils were made from whatever discarded paper was on hand at the moment, the report noted that there seemed to be two distinctly different weights of paper. The lighter papers are roughly the weight of construction paper. The heavier papers are approximately the weight of the paper used to make manila file folders. The author speculates—and so far, paint analysis has confirmed—that the stencils cut from the lighter weight papers were used in the original decoration of the cornices, whereas those cut from the heavier papers were used in later restenciling.

In addition to this distinction, it has been noticed that, although the number of tack holes in the stencils indicates that they were used many times, those cut from the lighter paper show less accumulation of paint. This suggests that they were used by a highly skilled stencil artist who employed a dry brush and a light touch. The heavier weight stencils, by contrast, show a significant paint buildup, and in some cases one can even see brush marks in the paint. These were apparently used by a less skilled artist, and it explains the need to have the stencils cut from a heavier grade paper. These observations, while they do not specifically help date the stencils, do suggest that the later stenciling work was of lesser quality.

## Results of Paint Analysis

One important benefit of the decision to remove sections of each cornice for research and conservation was that it was possible to X-ray them at the author's conservation facility (Fig. 5). These X rays enormously simplified the task of locating the various elements of the design; however, in the process of microscopic analysis, unexpected stenciled elements were occasionally discovered on the cornice that were not noticed on the X ray.

The results of the physical examination thus far (two of the five cornices have been analyzed) indicate that most elements were painted three times before the 1962 overpainting of the cornice decoration. In the

Figure 5

X-ray mosaic of the removed section of the stairhall cornice. New York State Office of Parks, Recreation and Historic Preservation, Bureau of Historic Sites, Waterford, N.Y.

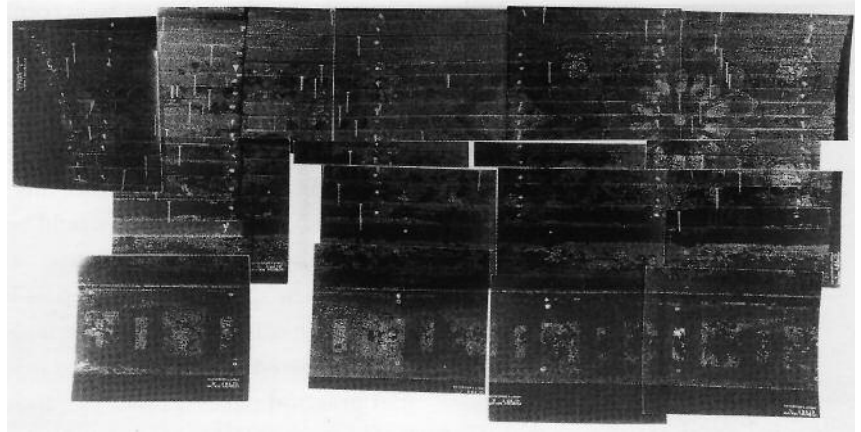

most exposed areas—the lowest boards—an additional layer or two of paint are sometimes found; in protected areas, there are occasionally fewer. This means that they were painted on an average of every twenty-five to thirty years. However, the physical evidence concurs with the documentary evidence in suggesting that the repainting did not take place in distinct campaigns. A comparison of chromochronologies of different elements shows that a paint that appears as the second finish layer in one place may be the third finish layer in another, et cetera. This, in turn, suggests that, while the colors and patterns on the cornices may have been altered over the years, it is unlikely that there was ever a second (or third) consciously developed design that superseded the original one. Since there was no way of knowing exactly when any of the “touching up” was done, or whether it was done by Frederic Church or his son Louis (who inherited the house on his father’s death), it was ultimately decided that it was more appropriate to restore the original decoration. In this way, the conservators could be sure that they were restoring the artist’s intent; they felt reasonably comfortable that that intent had not changed over the last decades of the artist’s life.

As is frequently the case with architectural paints, analysis of the composition of the paints was done only where necessary to reconstruct original colors. Paints used in architectural restorations are usually chosen based on practical considerations (durability, color retention) and general aesthetic qualities (gloss, texture). Rarely does a restoration of architectural paint involve duplicating an original paint exactly. Lead testing did show that the original paints all included some lead, except where the darkness or saturation of the color precluded it. Pigment analysis was done to determine whether a blue paint found at the bottom of one cornice, the area least protected by the roof and hence badly weathered, was in fact the same paint as a darker blue that appeared in a more protected location on the same cornice. This proved to be the case.

Paint analysis also revealed an interesting difference between the techniques used by the original stencil artist and those of later artists. Where one design element was made up of several stencils, using different colors, the original artist frequently applied those colors contiguously, like areas of color in a mosaic, rather than one on top of another—which is how the later artists chose to apply their paints. Presumably the reason for the former was to minimize the buildup of paint. As it turned out, the original artist’s concern was a valid one: the areas of greatest paint loss on the cornices are those specific areas where there is built-up decoration.

---

## Restoration

Given the method chosen to accomplish the research (that is, for the author and coworkers to do it themselves over a period of years), it made sense to train staff painters to do the decorative work, as well. Because of the distance from which the cornices are viewed, precise craftsmanship was less of an issue than it would be, say, on the interior, where the stenciling is at eye level. Therefore, this was a good opportunity for on-the-job training. Additionally, staff would be able to perform whatever maintenance was required in the future.

The question of materials was more complicated. As indicated earlier, the original paints were largely lead-based, and the conservators were prepared to use lead-based oil paints to restore the cornices if they met practical needs. However, modern coatings were also considered in the process of determining what type of paint would be most durable and provide the most permanence of color. A number of paint chemists were consulted—some associated with commercial paint manufacturers. All agreed that the best paint to meet both criteria would be a top quality, commercially available acrylic house paint. On this unanimous recommendation, an acrylic system was chosen. To confirm its effectiveness, a test panel was created in an exposed but inconspicuous spot. Three systems are currently being tested side by side: a homemade, lead-in-oil system; a commercial alkyd-based system; and the acrylic system. This will allow monitoring of their performance relative to one another, and any future approaches to the treatment of the cornices may be modified according to the test results.

---

## Conclusion

Figure 6

Decorative scheme to be restored to the stairhall cornice, CAD-generated drawing (colors are approximate due to the limited number of colors available on the ink-jet plotter). New York State Office of Parks, Recreation and Historic Preservation, Bureau of Historic Sites.

To date, one large but relatively modestly decorated cornice, that of the service wing of Olana, has been restored. Research has been completed on a second cornice, called the *stairhall* cornice (Fig. 6), which is small but richly painted and gilded. It is scheduled to be restored in the fall of 1995.

Although the research on the cornices is far from complete, and it is premature to draw conclusions, some interesting information has come to light about Church's aesthetic vision. The architectural woodwork below the cornice level is painted largely in the colors of the masonry units: brick red and brick yellow, a terra-cotta color, a brown-black (as some of the bricks are painted), and a tan color similar to that of the stonework. These earthy colors are not unusual for houses of this period, and, indeed, they





Figure 7  
Frederic E. Church, *Cotopaxi*, 1862. Oil on canvas, 121.9 cm × 215.9 cm. Detroit Institute of Arts.

appear on the cornices as well. However, on the cornices they are combined with and visually eclipsed by a range of highly saturated primary and secondary colors—orange and red-orange, clear blues and greens—which were unheard of for architectural decoration at that time and were even outside the varied and idiosyncratic color palette that Church used on the interior of the mansion. For color schemes similar to those chosen for the cornices, one must look to Church's work on canvas. The dramatic and richly conceived palettes of sunrises and sunsets—*Twilight in the Wilderness* or *Cotopaxi* (Fig. 7), for example—are not unlike those used on the cornices, although the formal aspects of these paintings and the cornice decoration could hardly be more different. Perhaps Church intended the cornices to reflect and, in their own way, respond to the magnificent celestial displays that nature produced all around his hilltop home.

---

## Acknowledgments

The author wishes to thank Joyce Zucker, paintings conservator at the New York State Bureau of Historic Sites, and Karen Zukowski, curator at Olana, for the benefit of their considerable experience with Frederic Church's oeuvre and for adding their astute observations to this article. The author is also grateful to Mary Betlejeski, assistant paintings conservator, for maneuvering the bulky sections of removed cornice through the X-ray process, and for providing pigment analysis where it seemed warranted. Lastly, the results of this analysis would have been virtually impossible to communicate without James Briggs's meticulous and beautiful graphics.

---

**Note**

- 1 A perpetual calendar is a reference table that can be used to determine the day of the week on which any given date falls.

---

**References**

- Church, Frederic Edwin**
- 1885 Letter to Martin Johnson Heade, 22 September. Olana State Historic Site archives, Hudson, New York.
- 1886 Letter to Erastus Dow Palmer, 20 June. Olana State Historic Site archives, Hudson, New York.
- Van Dolsen, Nancy**
- 1983 An unending process: Frederic E. Church and the stenciling of Olana. Report, Olana State Historic Site, Hudson, New York.



PART SIX

## Scientific Research

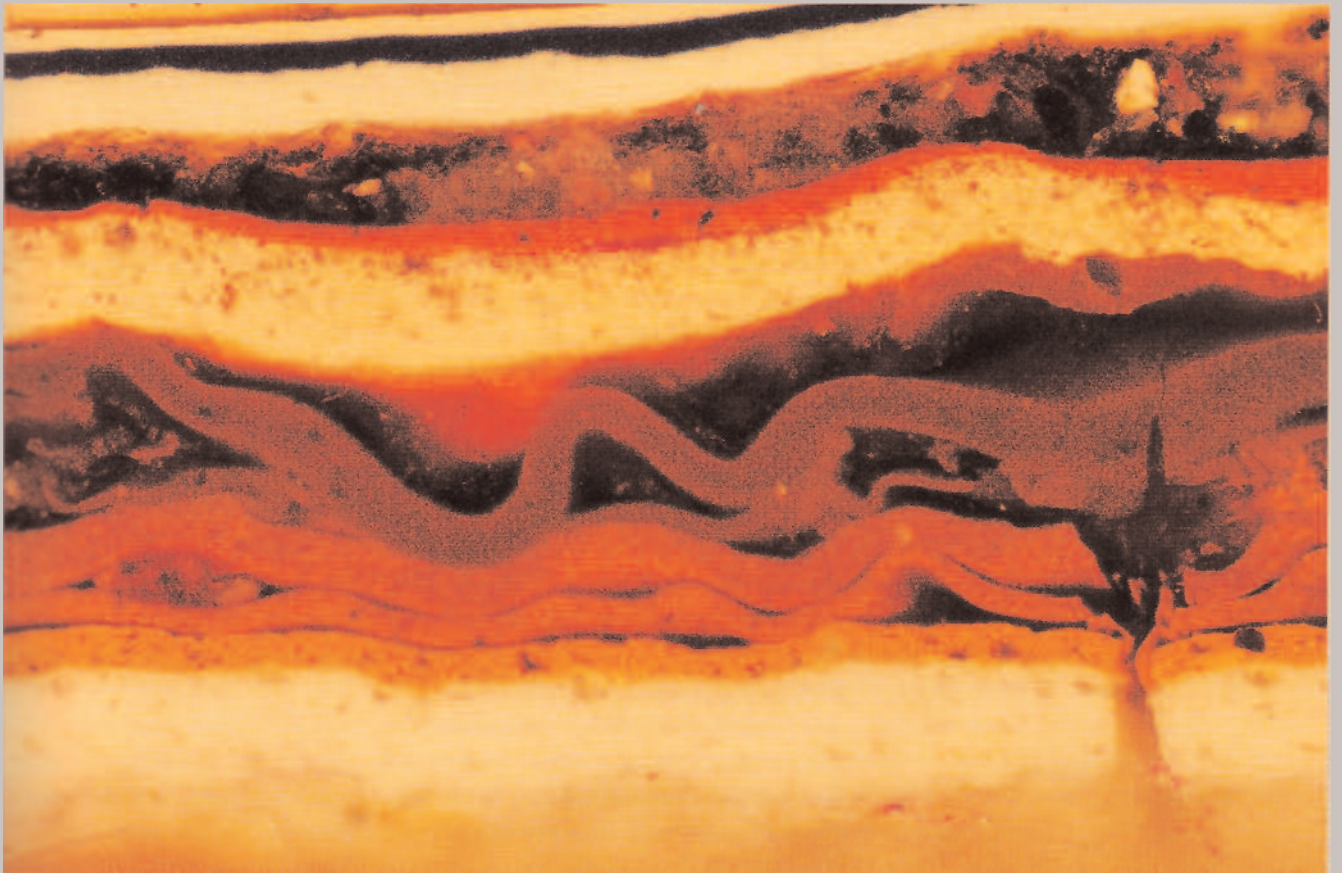

# Structural Response of Painted Wood Surfaces to Changes in Ambient Relative Humidity

*Marion F. Mecklenburg, Charles S. Tumosa, and David Erhardt*

**F**LUCTUATIONS IN AMBIENT RELATIVE HUMIDITY (RH) produce changes in the materials that make up painted wood objects, altering their dimensions and affecting their mechanical properties. The use of wood as a substrate for paint materials presents a particular problem. In the direction parallel to the grain of a wood substrate, applied paint materials are considered to be nearly fully restrained because wood's longitudinal dimension remains essentially unchanged by fluctuations in relative humidity. In the direction across the grain, however, moisture-related movement of an unrestrained wood substrate may completely override the less responsive paint layers. In this situation, stresses induced in the ground and paint layers due to changes in RH are completely opposite to the stresses parallel to the grain.

To quantify the effects of RH fluctuations on painted wooden objects, tests were conducted to determine the individual swelling responses of materials such as wood, glue, gesso, and oil paints to a range of relative humidities. By relating the differing swelling rates of response for these materials at various levels of RH, it becomes possible to determine the RH fluctuations a painted object might endure without experiencing irreversible deformation or actual failure (cracking, cleavage, paint loss) in the painted design layer.

Painted wooden objects are composite structures. They may incorporate varying species of wood, hide glues, gesso composed of glue and gypsum (calcium sulfate) or chalk (calcium carbonate), and different types of paints and resin varnishes. Paint media can include wax, egg tempera, oils, and combinations of these. These materials have differing mechanical properties and varying responses to moisture fluctuations. Painted wood surfaces also vary in complexity. The simplest consist of paint applied directly to wood, but more complex examples, such as early Italian panel paintings in tempera, may have a layer of fabric glued to the wood, a gesso ground to produce a smooth painting surface, paint applied above the gesso, and a clear varnish.

For the past four centuries, oil paint, rather than tempera, has been the most commonly used pigmented coating for wood. Therefore, oil paint on a wood substrate will serve as the focus of this chapter. Hide glue and gesso—materials with distinctive mechanical behavior—will also be included, since they are often incorporated into painted wooden objects. Properties of the individual materials will be discussed here first, followed by aspects of the painted wooden object as a composite structure.

Regarding the effect of RH fluctuations on painted wooden objects, there are three basic conditions of concern. The first, a common construction problem, is built-in restraint that prevents joined wood from naturally swelling and shrinking across its grain in response to RH fluctuations. A variation of this occurs when wood acts as its own restraint (uneven moisture penetration can induce strain into both the dry and wet regions of otherwise unrestrained wood). A second condition of concern is restraint placed on the paint (and any other components of the design layer) by the wooden substrate in the direction parallel to the wood grain (the longitudinal direction). A third and equally important condition involves the RH response of the design layer itself in the direction perpendicular to the grain of an unrestrained substrate. Here, differences in the rate of response of the various materials to changes in ambient RH become especially significant. The following examines these three conditions and identifies the worst cases.

---

## The Wood Support

Over the centuries, many species of wood have been used as paint substrates, with each geographic region favoring certain woods for reasons of fashion, ease of use, and availability. For example, painters from northern Germany and Holland preferred oak while those in southern Germany favored such woods as pine, fir, larch, linden, and ash. In Italy, poplar and cypress were used. American woods, such as cottonwood and mahogany, were imported into Europe for use as supports (Doerner 1962).

Wood responds to moisture by swelling and shrinking with increases and decreases in ambient RH. But wood is anisotropic, meaning that moisture-related dimensional changes vary in its three principal axes—longitudinal (parallel to the grain), radial, and tangential (see Hoadley herein). The most pronounced moisture response is in the tangential direction, where wood may swell up to eighty times as much as in its negligibly responsive longitudinal direction. In the radial direction, wood swells about half as much as it does tangentially (*Wood Handbook* 1974).

If restrained during changes in relative humidity, wood can develop high stresses and strains. If the change in environmental moisture is extreme, the wood may be plastically (permanently) deformed, a condition that can lead to cracking. How much change in relative humidity is necessary to bring about plastic deformation and failure in fully restrained wood and paint materials? The following sections outline experimentation and analysis designed to answer this question.

---

## Mechanical Testing of Woods

Recent research into the response of wood to changes in RH examined the cross-grain mechanical properties of tangentially sawn wood samples of several species (Mecklenburg, Tumosa, and McCormick-Goodhart 1995). Using this testing program, the yield point (the amount of strain necessary to produce permanent plastic deformation) and strength (the amount of stress necessary to cause breakage) of each wood sample could be established. Figure 1a, b shows the stress-strain plots of different samples of cottonwood and white oak, tested at a range of relative humidities. The samples were all incrementally loaded across the grain, and tests were conducted allowing 30 seconds of stress relaxation at each loading point. In this way, time-dependent variations in behavior were greatly reduced. Disparities in the starting points of the tests reflect changes in cross-grain

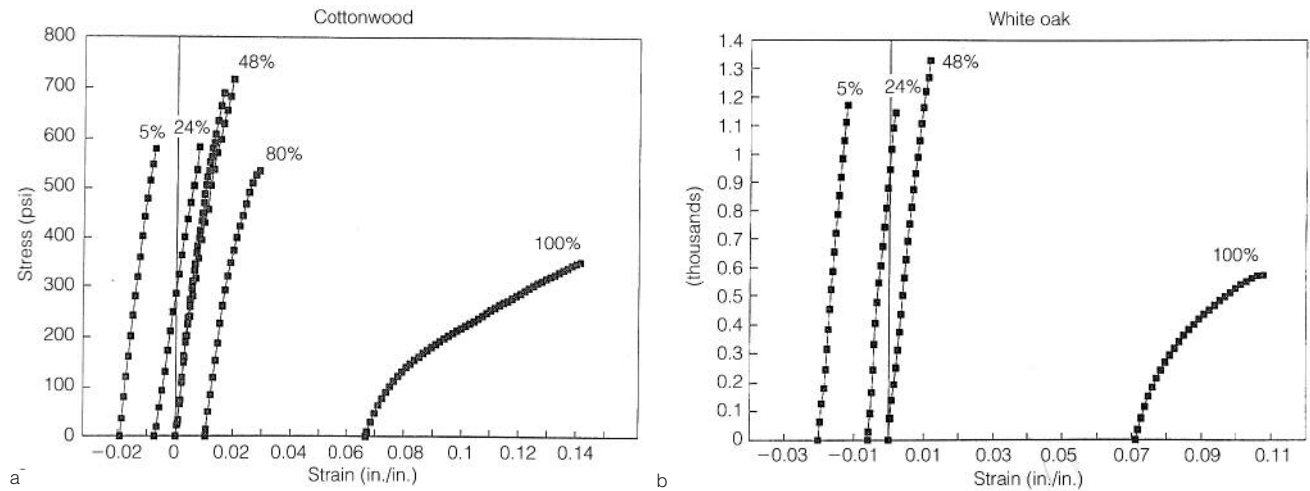

Figure 1a, b  
The stress-strain curves for cottonwood (a) and white oak (b), tested at various relative humidities. The space between each plotted test relates to stress-free dimensional change in the sample when the ambient RH is raised or lowered.

dimension, due solely to RH-dependent differences in the moisture content of the wood. The test temperature was approximately 22 °C in all cases. The strengths of the woods are the stresses noted at failure—the end point of each test. Cottonwood, white oak, and American mahogany are strongest at around 50% RH. White oak has the highest strength at around 1340 pounds per square inch (psi).<sup>1</sup>

The amount of strain required to go beyond the elastic (reversible) region to the plastic (irreversible) region can be determined by unloading the specimen at different strain intervals. Testing shows that the yield point of most polymers, including wood, is about 0.004. Figure 2 shows that cottonwood has an initial yield point of 0.004 but, when strain-hardened, it stretches farther.

## Environmentally Induced Strains

One can easily recognize that if a hygroscopic material is restrained and desiccated it will experience an increase in stress. What is not so evident is that there is an increase in strain. Too often strain is associated with external deformation when, in fact, no external movement is necessary for strain to occur. Consider a hygroscopic specimen that is allowed to shrink freely from an initial length ( $L_i$ ) to a final length ( $L_f$ ) when desiccated from a high relative humidity ( $RH_h$ ) to a low relative humidity ( $RH_l$ ). If, under

Figure 2  
The stress-strain plot of cottonwood that is loaded beyond its yield point of 0.0045 at around 48% RH. After unloading, this specimen exhibits a plastic deformation strain of approximately 0.0014. Reloading indicates an increased yield point of 0.0071.

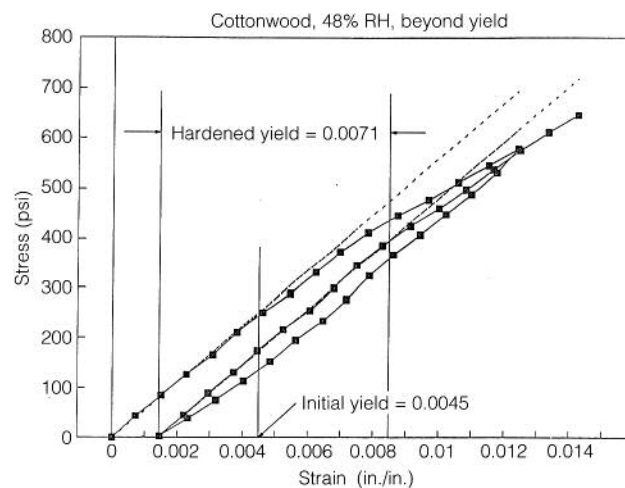

equilibrium conditions, the specimen is now stretched back to its original length ( $L_i$ ) it will clearly undergo an increase in stress and strain. It is, however, at the lower relative humidity ( $RH_i$ ). This new state of stress, strain, and relative humidity is no different from that of a specimen restrained at  $L_i$  and  $RH_h$ , then desiccated to  $RH_i$  without being allowed to shrink (Mecklenburg and Tumosa 1991). The specimens reach identical states following the two different experiments, ending with the same cross-grain dimension and the same relative humidity. The restrained test specimen does not exhibit dimensional change, although it was subjected to an increase in strain. Now it is necessary to determine the amount of change in RH that will cause strains approaching the yield point when a material is fully restrained. If the yield point is not exceeded, then a fully restrained specimen may be subjected without damage to strain induced by variations in RH.

---

### The Swelling Isotherm and the Moisture Coefficient of Expansion

The amount a material swells or shrinks can be expressed as strain (a ratio of the dimensional change of the material to its initial dimension) versus RH. This simply entails holding the temperature constant, measuring the cross-grain dimension ( $L_{RH}$ ) of a specimen at different RH levels, then establishing an initialized length ( $L_o$ ), usually the dry length. The strain ( $\epsilon$ ) is calculated as

$$\epsilon = (L_{RH} - L_o) / L_o \quad (1)$$

This form of displaying the dimensional response of a material to changes in moisture is useful in relating dimensional properties to mechanical properties of materials. Figure 3a shows the swelling isotherm (at 22 °C) of cottonwood in the tangential direction. This plot shows significant dimensional response to moisture at the extremes of the RH scale and relatively little response to moisture in the region bounded by 30% and 70% RH. The implications are that moisture changes will have the greatest structural effect at extreme low and high RH levels and the least effect in the central RH regions.

It is necessary to determine the allowable RH fluctuations for cottonwood in any ambient RH environment: the RH changes that will not strain the wood beyond its yield point. To do this, one may use the swelling isotherm and simply measure the change in RH that will cause a strain no greater than 0.004 inch (0.01 cm) of dimensional change per inch of initial dimension (the yield point for cottonwood determined in Figure 2). Alternatively, one may determine the rates of dimensional change ( $d$ ) experienced by a material across the entire range of RH from a polynomial fit of the swelling data. These rates, hereafter known as moisture coefficients of expansion ( $\alpha$ ) are calculated as

$$\alpha = d\epsilon / dRH \quad (2)$$

The moisture coefficients of expansion for cottonwood are plotted in Figure 3b. Most texts on the swelling of wood report the moisture coefficient as a constant, but Figure 3b demonstrates that this is not the case. This figure also shows that the lowest values of the coefficient of expansion correspond to the flattest portion of the swelling isotherm, namely from 30% to 70% RH.

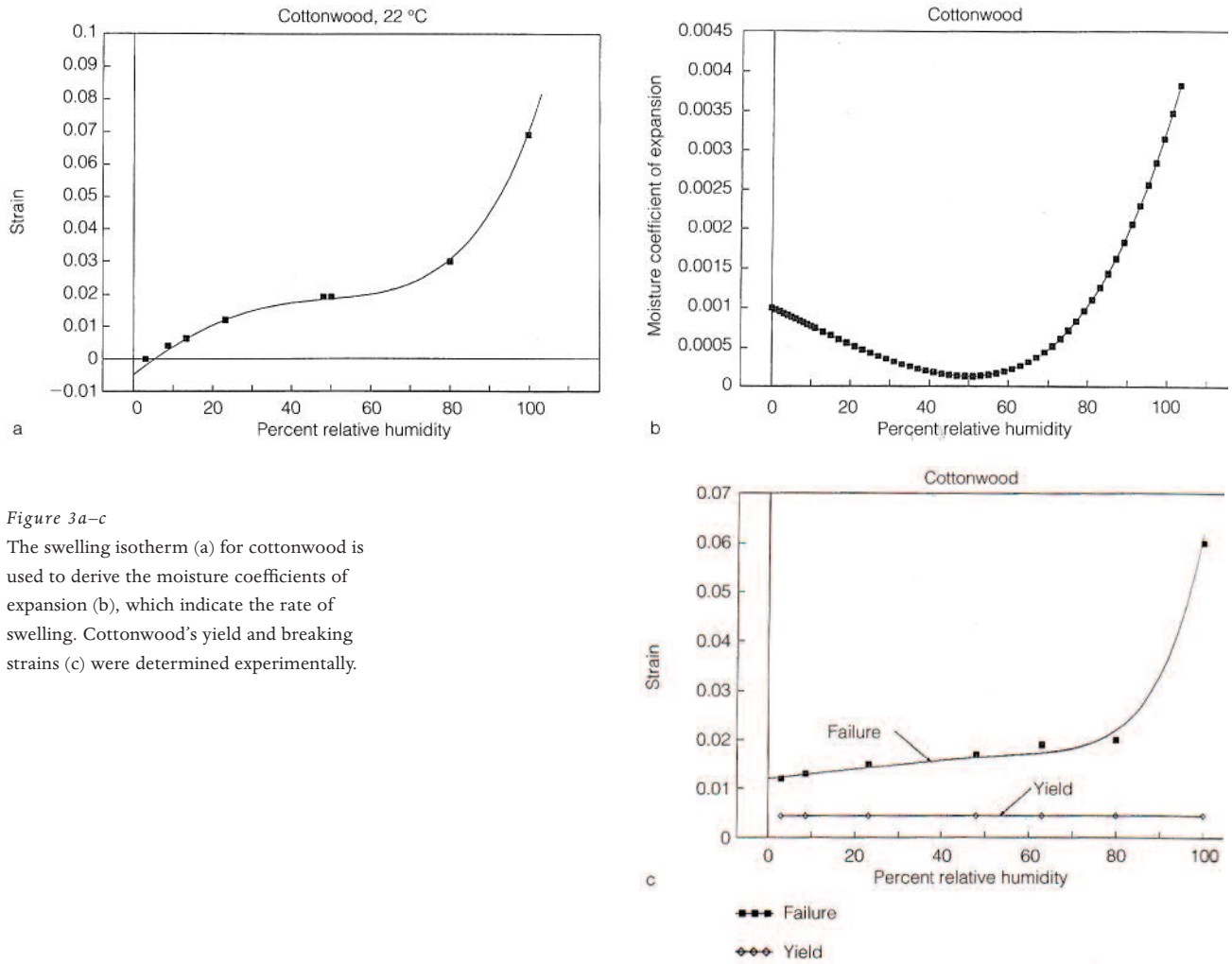

Figure 3a-c  
The swelling isotherm (a) for cottonwood is used to derive the moisture coefficients of expansion (b), which indicate the rate of swelling. Cottonwood's yield and breaking strains (c) were determined experimentally.

Using equation 2, the strain change ( $\Delta\epsilon$ ) for any RH change can be calculated as

$$\Delta\epsilon = \int \alpha \, dRH \tag{3}$$

where  $\alpha = d\epsilon/dRH$ .

To determine the effect of a given strain change on cottonwood, one must know the wood's yield point and the amount of strain necessary to cause it to break. These values are determined experimentally and are shown in Figure 3c. The yield point for new cottonwood is about 0.004 at all RH levels, and its breaking strains increase with increasing RH.

Integrating equation 3 allows one to determine the change in RH that will produce a particular change in strain. One assumes a starting RH of 50% and integrates to another RH level associated with the strain change in question. In the case of cottonwood in the tangential direction, at 50% RH the yielding strain is 0.004, and the breaking strain is 0.017 (Fig. 3c). The associated RH changes required to induce these strains for a sample of cottonwood restrained in the tangential direction (Fig. 4a) are from 50% to 30% RH for yielding in tension, 50% to 67% for yielding in compression, and 50% to 14% for complete failure in tension. No line for complete compression failure is shown in Figure 4a, as compression failures take different forms, from the crushing of the cell walls to buckling

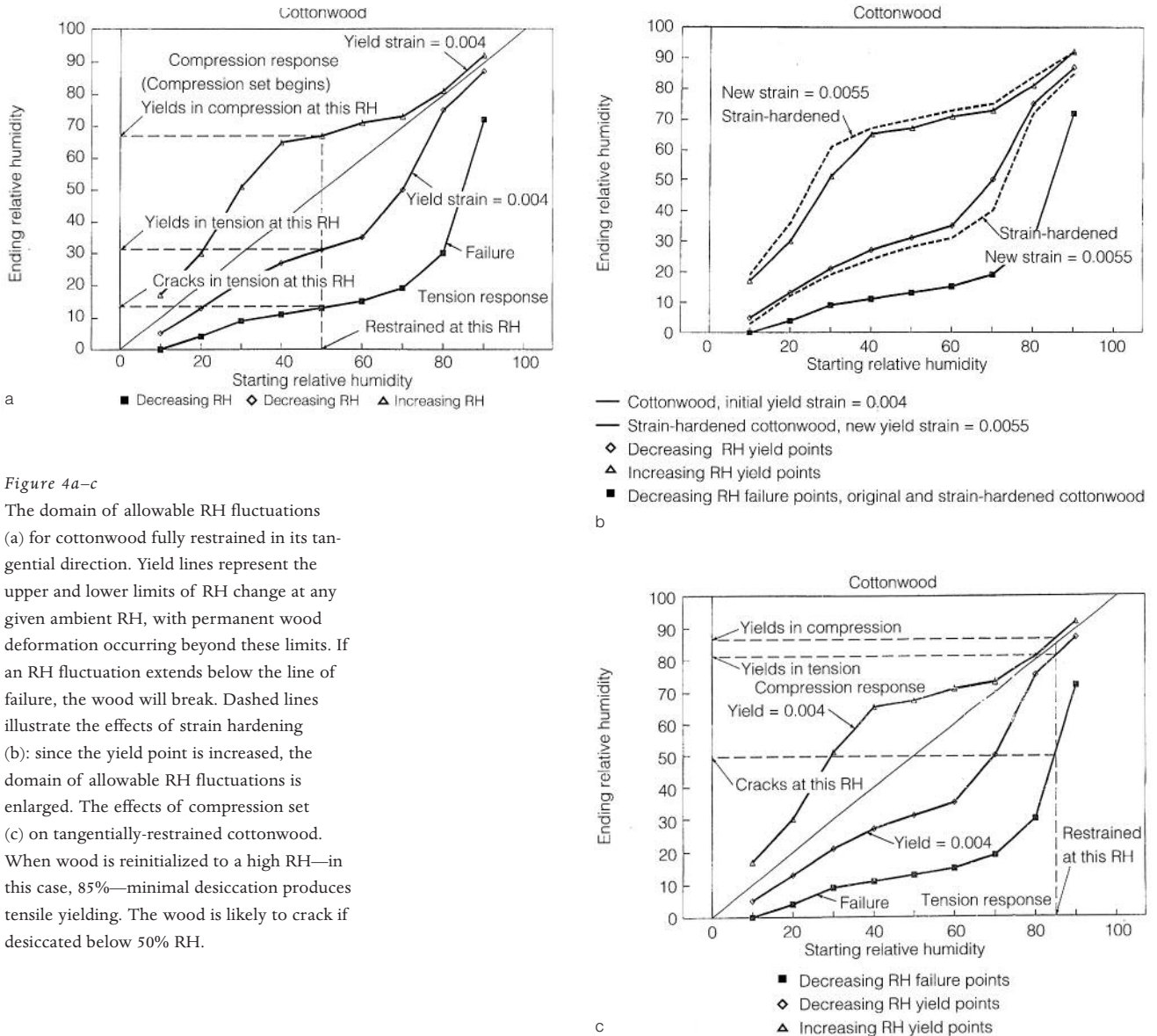

Figure 4a-c

The domain of allowable RH fluctuations (a) for cottonwood fully restrained in its tangential direction. Yield lines represent the upper and lower limits of RH change at any given ambient RH, with permanent wood deformation occurring beyond these limits. If an RH fluctuation extends below the line of failure, the wood will break. Dashed lines illustrate the effects of strain hardening (b): since the yield point is increased, the domain of allowable RH fluctuations is enlarged. The effects of compression set (c) on tangentially-restrained cottonwood. When wood is reinitialized to a high RH—in this case, 85%—minimal desiccation produces tensile yielding. The wood is likely to crack if desiccated below 50% RH.

of the panel itself. Buckling is influenced by the geometry (thickness) and restraint (boundary conditions) of the panel.

### Allowable RH Fluctuations

Figure 4a effectively establishes the allowable RH fluctuations cottonwood restrained in the tangential direction may sustain without damage. The tension and compression yield lines set the RH limits (ending RH) from which the ambient RH (starting or equilibrium RH) can deviate. The area between these lines can be viewed as the allowable RH zone. Since the data relate to the wood’s tangential direction, this represents the worst-case condition for cottonwood. If the wood were tested in the radial direction, the allowable RH fluctuations would be greater. This is because the yield point is still at least 0.004, but the moisture response of cottonwood in the radial direction is about half that in its tangential direction.

If the wood were wholly unrestrained, Figure 4a would not be pertinent, but in real-world conditions one assumes there is restraint. Restraint may result from basic construction techniques (e.g., wood

components are often securely joined with grains mutually perpendicular). Bulk wood also experiences internal restraint when the exterior responds more quickly than the interior to an RH change. Battens and locked cradles on the backs of panels restrain them from freely expanding and contracting. Even under the worst structural circumstances, however, the tests indicate that cottonwood can endure significant RH fluctuations if the ambient RH is centered between 35% and 60%. At higher or lower RH the allowable fluctuations are dramatically reduced. Cottonwood forced beyond the allowable range will experience yielding. If the excursion is severe enough, it is possible that the material cannot return to the central zone without breaking.

If the wood has been strain-hardened, which is probably the case for all old woods, the RH change required to reach the yield point increases. Figure 4b shows the plots for tension and compression when the yield points have increased from 0.004 (solid lines) to 0.0055 (dashed lines). In effect, the allowable elastic or reversible RH fluctuations have been increased. It is important to point out, however, that neither the breaking strength of the material has changed, nor the associated change in RH sufficient to cause cracking.

If a cottonwood sample is restrained at 50% RH and the humidity is increased to 85% RH, the wood will experience plastic deformation in compression, or *compression set*. The wood now has been effectively shortened, and upon desiccation from 85% it begins to experience tension. In effect, the wood has been reinitialized to a restrained condition at 85% RH. Figure 4c shows that, upon desiccation from 85% to about 81% RH, the sample has already attained yield in tension. Upon returning to 50% RH, the sample will most likely crack. This illustration explains why restrained wooden objects subjected to very high humidities or stored outside in equally humid environments often suffer damage when brought into a well-controlled museum environment. The degree of control of the museum environment is thus not the issue. The substantial change from the high humidity to a moderate environment is the cause of failure.

Since wood is most dimensionally responsive in its tangential orientation, tangentially restrained wood is the most vulnerable to RH-induced strain development. Therefore, if one wishes to set a criterion for the allowable RH fluctuations for a restrained panel, one should examine strain development in the tangential direction as the worst case condition. Figure 5 shows the allowable fluctuation plots for white oak in the tangential direction. It is quite similar to the cottonwood plot (Fig. 4a).

---

## The Effects of Wood Variability within a Single Species

Wood samples of the same species can vary considerably in their mechanical properties. It is of interest to know how this variability affects the material's response to fluctuations in the environment. Samples of spruce obtained from two different sources were tested mechanically, with respect to their dimensional response to moisture. The difference in their mechanical behavior was substantial. In Figure 6a, results from tensile tests are plotted as stress-strain curves conducted at 50% RH and 22 °C. The sample A spruce was 4.5 times as stiff and twice as strong as sample B. This difference was more or less consistent over the whole RH range. The yield points for new samples of both woods were 0.004, but the breaking strains were substantially different, as shown in Figure 6b. Even though sample A was stronger, it broke at strains one-third as great as those for sample B, over the entire RH



Figure 5  
The domains of allowable RH fluctuations for white oak, fully restrained in their tangential directions.

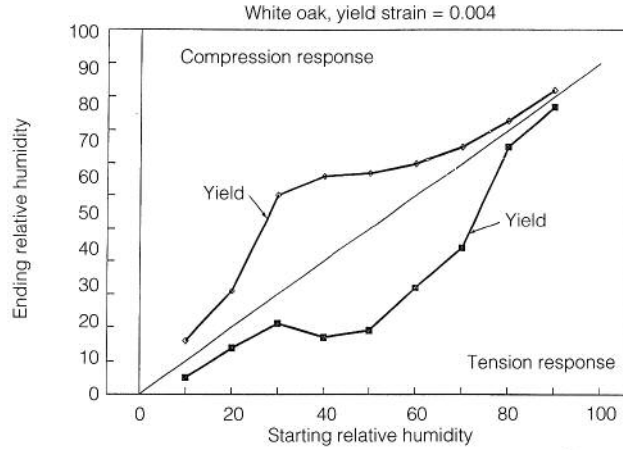
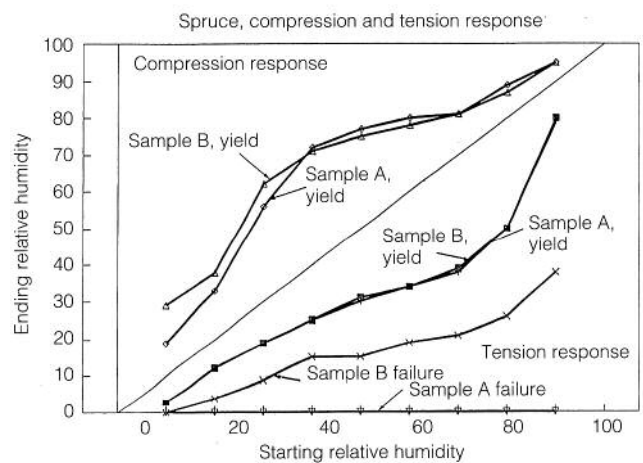
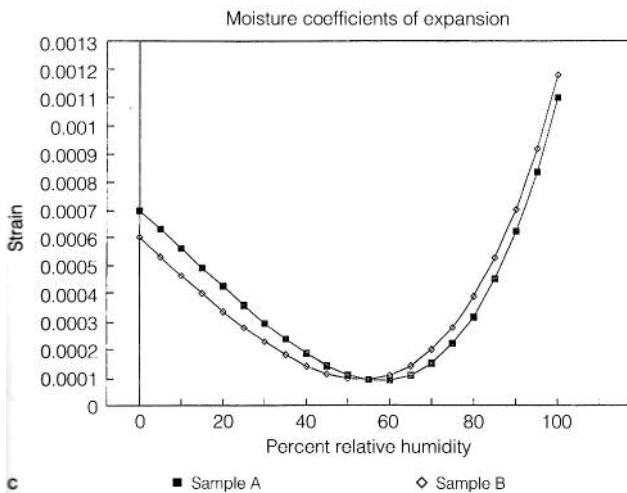
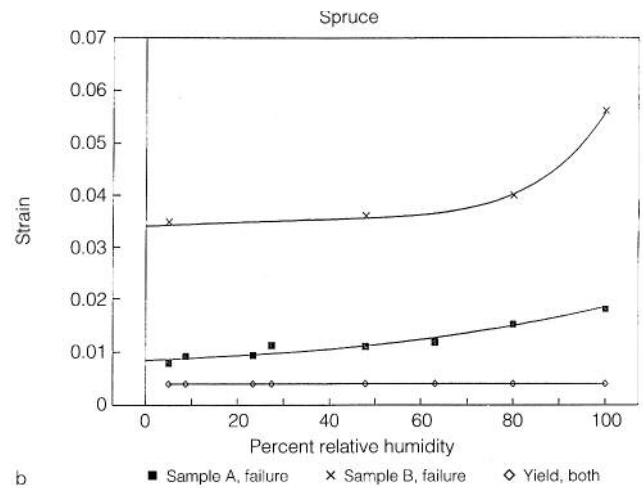
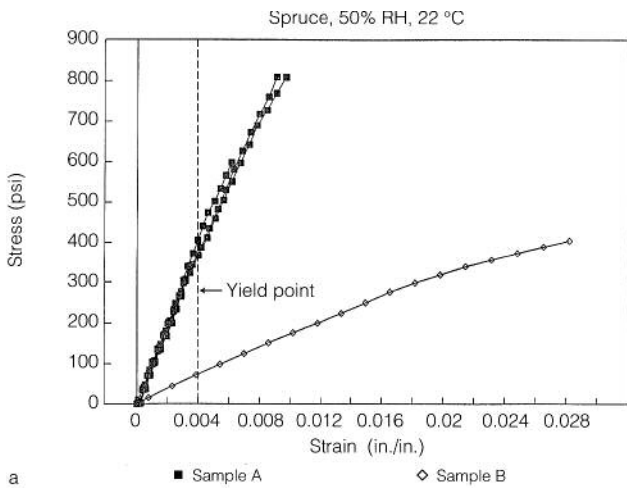

Figure 6a-d  
The stress-strain plots (a) and the experimentally measured yield and breaking strains (b) for two samples of tangentially-restrained spruce show substantial variations in mechanical properties. However, the moisture coefficients of expansion (c) and the domains of allowable RH fluctuations (d) are nearly identical.

range. When measuring the swelling behavior, the two materials showed little difference, and the moisture coefficients of expansion were quite similar (Fig. 6c). Computing the RH fluctuations that are required to induce yield strains (Fig. 6d) in either compression or tension showed insignificant differences. In addition, these RH fluctuations were greater than those for woods discussed previously in this article. Differences occurred in the RH fluctuation that was required to cause failure in tension. Sample B acted quite



similarly to the three previous woods, while sample A is difficult to break with any RH change. The interesting aspect of this comparison of two samples of spruce is that mechanical properties, such as stiffness and strength, do not necessarily influence the restrained specimen's yield points (the amount of RH-induced strain required to cause plastic deformation). By contrast, stiffness and strength do influence the restrained specimen's points of failure (the amount of RH-induced strain required to break the sample).

## Hide Glue

Hide glue is a material often associated with painted wooden objects, whether used to join the components, to size the surface prior to painting, or as an ingredient in gesso applied to prepare a smooth painting surface. Hide glue is one of the materials most dimensionally responsive to moisture. The swelling isotherm for a particular type of hide glue (rabbit-skin glue) was developed from two separate samples of the same material (Fig. 7a). The newly cast material shrinks freely when initial high RH levels are reduced (Mecklenburg and Tumosa 1991). The total shrinkage can be as much as 6% when desiccating from 90% to 10% RH.

Over short time spans—days to weeks—one can measure a yield point of about 0.004 to 0.005 for rabbit-skin glue (the breaking strains are measured at approximately 3% to 4%—strains of 0.03 to 0.04—in extremely slow tests). For changes in RH that occur within these short periods, it is possible to determine the RH fluctuations that will induce yield strains in restrained hide glue (Fig. 7b). In effect, at 50% RH, the short-term RH fluctuations may range  $\pm 11\%$  before yield point is reached. Since hide glue has no covalent cross-links, it is prone to stress relaxation over periods ranging from six to twelve months, depending on the RH level (Mecklenburg and Tumosa 1991). Therefore, over a long period of time any induced stresses may relax. If subjected to excessive RH (over 85%), however, the glue reactivates; as the reactivated glue desiccates with decreases in RH, extremely high stresses develop.

Figure 7a, b

The swelling isotherm for rabbit-skin glue (a) and the domain of allowable RH fluctuations for fully restrained rabbit-skin glue (b) at any given ambient RH.

## Hide glue response when attached to an unrestrained wood support

Theoretically, rapid extreme changes in RH could cause significant damage to objects sized with glue, due to the resulting high stresses. While such

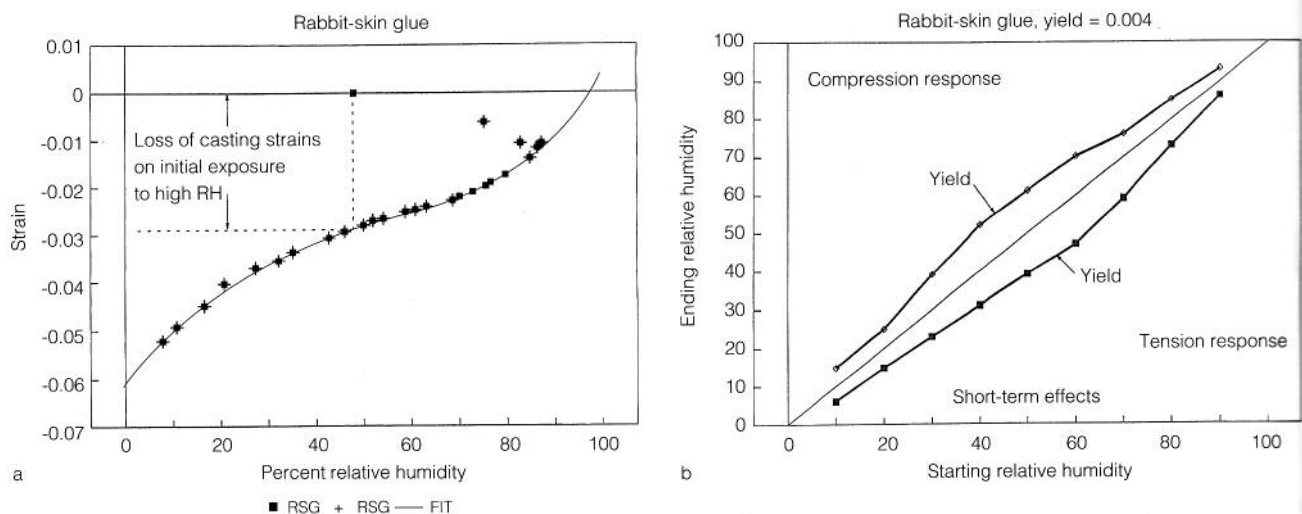

damage is common in paintings on sized canvas, the mass of the substrate in a glue-sized painted wooden object provides substantial resistance to stresses developing in the relatively thin layer of glue. Since wood has a very small dimensional response to moisture in its parallel-to-grain (longitudinal) direction, wood in this axis essentially serves as a full restraint for all materials attached to it—glues, fabrics, gessoes, and paint.

Across its grain, unrestrained wood will change dimensionally with RH changes. If the moisture coefficients of expansion of all materials attached to a wood substrate were the same as the wood, then RH changes would induce no cross-grain stresses in the attached layers. In reality, the expansion coefficients of the different materials vary considerably, but by comparing them it is possible to explore the effects of RH changes in the cross-grained direction of an unrestrained painted panel. Figure 8a compares the expansion coefficients of cottonwood and hide glue. At approximately 70% the plots intersect: at this RH, both wood and glue swell or shrink at the same rate. In the RH range from 35% to 60%, the glue attempts to swell or shrink at a slightly higher rate than the wood substrate. In this region, glue applied to cottonwood will develop stresses, but only a fraction of those that result from full restraint, since the shrinking or swelling of the wood approximates that of the glue. This is an example of partial rather than full restraint. In effect, the wood’s movement provides greater RH tolerances for the hide glue. The strains in the glue can be calculated using the following equation:

$$\Delta\epsilon_G = [(1 - \int\alpha_s dRH) - (1 - \int\alpha_G dRH)] / (1 - \int\alpha_s dRH) \tag{4}$$

where  $\alpha_s$  is the coefficient of expansion of the substrate, and  $\alpha_G$  is the swelling coefficient of the hide glue.

This equation can be used for any material applied to any substrate in any direction. For example, assume that the coefficient of expansion for the substrate is zero. In that case, Equation 4 simplifies to Equation 3. In the examples to follow, cottonwood will be the substrate since it is one of the most dimensionally responsive woods.

The calculated increase in RH tolerance for hide glue size on a wood substrate is illustrated in Figure 8b. Here, the hide glue is applied to an unrestrained cottonwood support, and the glue strains are plotted

Figure 8a, b  
A comparison of the moisture coefficients of expansion (a) for hide glue and cottonwood. Using Equation 4, these values enable one to determine the strain interaction of the glue with the cottonwood substrate (in both tangential and longitudinal directions) over the complete range of RH (b).

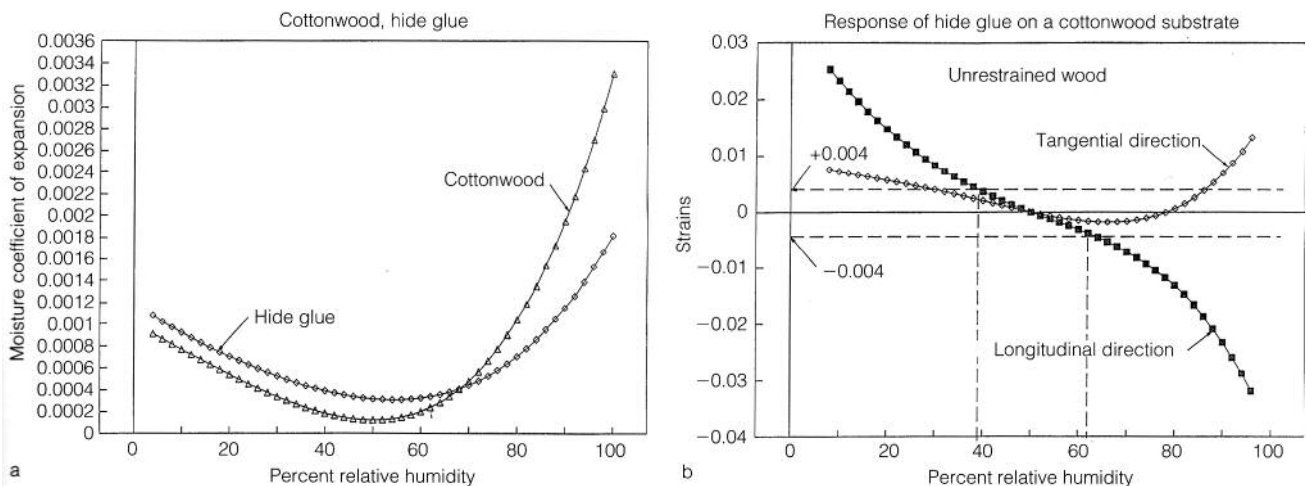

against RH in both the tangential and longitudinal directions. The longitudinal direction, in which the glue is essentially fully restrained (the wood's coefficient of expansion in that direction is assumed to be zero), is plotted by integrating Equation 4 from 50% RH going in both increasing and decreasing directions. The strains are as one would expect for fully restrained glue: high in tension (positive values) upon desiccation, and high in compression (negative values) upon increases in humidity. To determine the strains in the glue in the wood's tangential direction, Equation 4 was integrated again, now using cottonwood's tangential coefficients of expansion, shown in Figure 8a. In this direction, the wood substrate and the glue respond similarly to the moisture changes, significantly reducing the strains in the glue layer. With desiccation, the glue strains are in tension but are less than half those in the longitudinal direction. This is because from 50% to 0% RH, the glue coefficient is greater than that for the wood. Increasing the humidity from the 50% RH starting point produces different results. At about 68% RH, the wood coefficient becomes greater than the glue; the swelling of the wood actually overrides that of the glue, and the wood begins pulling the glue layer into tension.

Regarding allowable RH fluctuations, the strains upon glue in wood's fully restrained, longitudinal direction are the most severe, but it is clear that severe desiccation could cause cracking in the glue in both of the wood's directions. In addition, extreme humidification simultaneously subjects the glue to significant tension in the wood's tangential direction and severe compression in its longitudinal direction—both strains potentially leading to failure. Similar diagrams will be used to examine the response of gesso and paint layers attached to wood substrates.

---

## Gesso

Gesso is a mixture of a hide glue and gypsum or ground chalk, used to prepare a smooth, paintable surface on wood. Sometimes other inert materials, such as zinc white and clay, are incorporated. The ratio of inert solids to hide glue has a dramatic influence on the mechanical and dimensional properties of the gesso. This ratio can be expressed in the pigment-volume concentration (PVC). The higher the concentration of inert filler (higher PVC), the weaker, stiffer, and less dimensionally responsive to ambient moisture a gesso becomes, due to the smaller relative amount of glue. Figure 9a plots the dimensional response against RH for two gesso mixtures: PVC = 58.3, and PVC = 81.6. The lower PVC gesso has a maximum change of about 1.5% (strain = 0.015) over the entire RH range. The higher PVC gesso changes only about 0.6% over the same RH range, which is about one-tenth that of pure hide glue (in effect, PVC = 0) which swells as much as 6%. With the increased PVC, gesso will reach yield point and experience failure at dramatically lower strains, and the reasons for this were discussed in a recent study (Michalski 1990). Figure 9b shows the difference in the moisture coefficients of expansion for the two gessos. Both show lowest values (representing the lowest rates of dimensional response) between 50% and 60% RH.

As with all the materials examined, RH affects the mechanical properties of gesso. Tensile testing of one of the gessos (PVC = 58.3) shows a dramatic loss of strength with increasing RH (Fig. 9c). Here the low RH strains for the gesso tested are actually higher than those determined in the midrange RH tests. The yield strains are about 0.0025, and

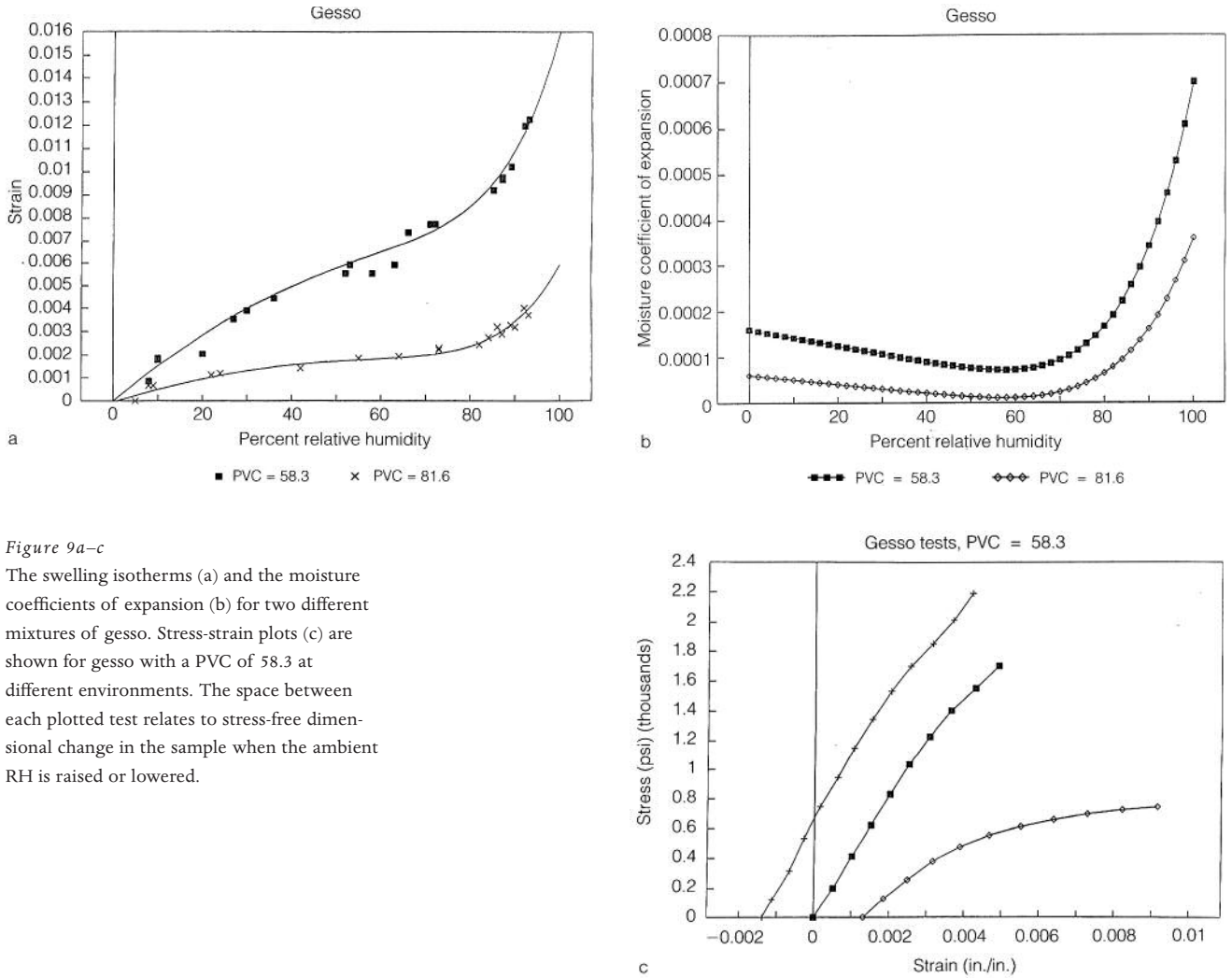

Figure 9a-c The swelling isotherms (a) and the moisture coefficients of expansion (b) for two different mixtures of gesso. Stress-strain plots (c) are shown for gesso with a PVC of 58.3 at different environments. The space between each plotted test relates to stress-free dimensional change in the sample when the ambient RH is raised or lowered.

the breaking strains again vary with RH but are generally lower than those for other materials associated with painted wood.

In spite of its low yield and breaking strains, gesso can be subjected to greater RH changes than most of the other materials under consideration before reaching its yield points. Figure 10a shows the RH changes required to induce yield and cracking in gesso (PVC = 58.3) fully restrained in the longitudinal orientation of a wood substrate. For example, beginning at an ambient RH of 50%, fully restrained gesso can desiccate to 26% RH before attaining yield in tension. The RH can go as high as 76% before yield is reached in compression. This is a direct result of the gesso's low moisture coefficient of expansion.

Figure 10b compares the swelling coefficients of gesso with those for cottonwood in its tangential direction. Here, the swelling coefficients of the cottonwood and the gesso are not only very low but nearly identical in the 40–60% RH range. This means that an unrestrained cottonwood panel and its applied gesso are swelling and shrinking very little and at almost exactly the same rate in this RH region; there is effectively little structural interaction.

Deviation from the mid-RH zone, however, has quite dramatic effects. Equation 4 was again integrated in order to explore the composite

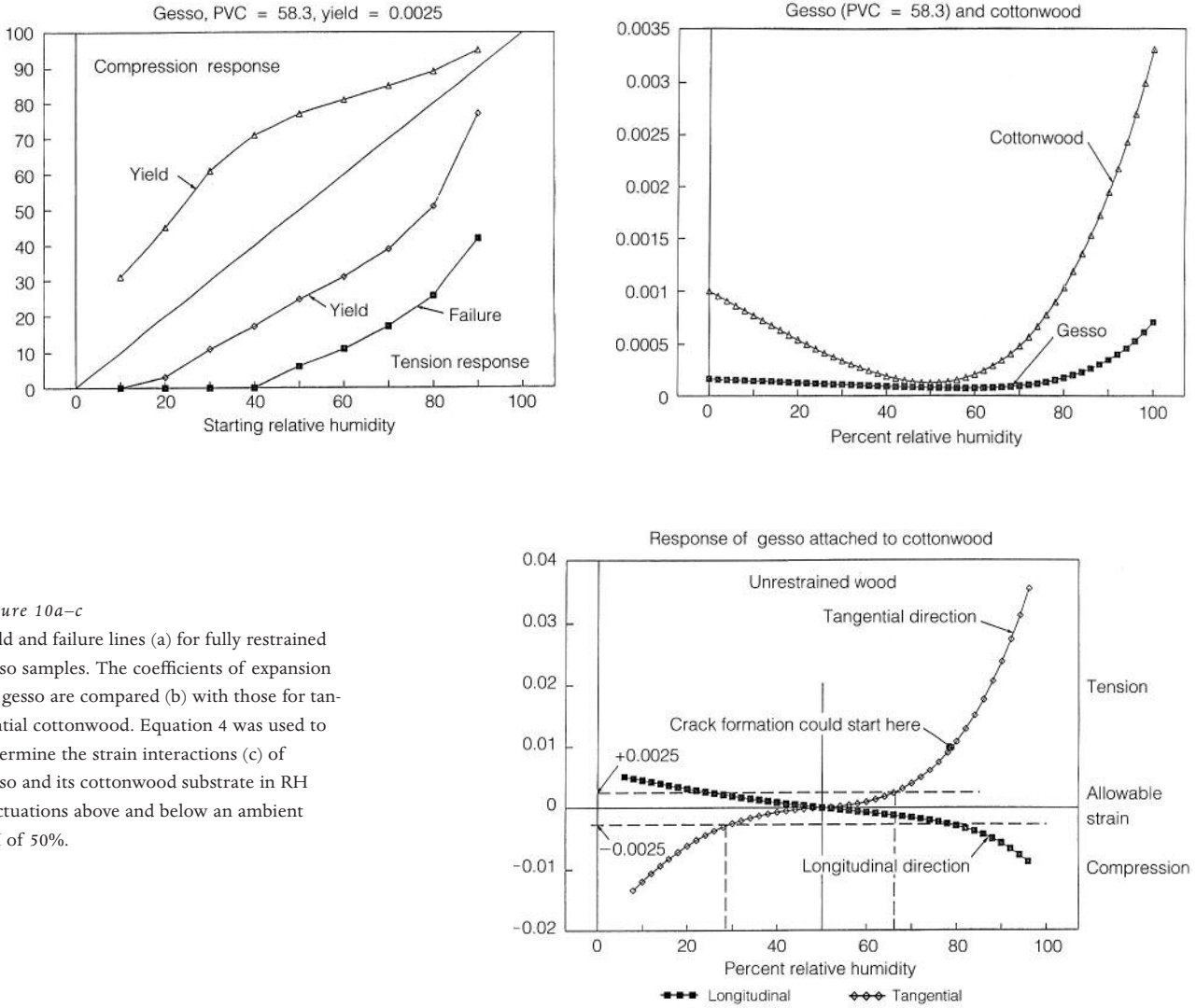

Figure 10a-c  
Yield and failure lines (a) for fully restrained gesso samples. The coefficients of expansion for gesso are compared (b) with those for tangential cottonwood. Equation 4 was used to determine the strain interactions (c) of gesso and its cottonwood substrate in RH fluctuations above and below an ambient RH of 50%.

effect when the gesso is bonded to a cottonwood panel, using a starting point of 50% RH. The results of this analysis are illustrated in Figure 10c, where gesso strains associated with both the tangential and longitudinal directions of the wood support are plotted against RH. In the longitudinal direction, full restraint is again assumed, and the RH fluctuations needed to induce yielding are quite large—from 50% to 26% RH in tension upon desiccation and from 50% to 76% RH in compression upon humidification. In the tangential direction, the mismatch of swelling coefficients for the wood and the gesso worsens dramatically as the high and low extremes of the RH range are approached (Fig. 10b). Consequently, Figure 10c demonstrates that desiccation will induce severe compressive strains in the gesso layer (which can cause cleavage and buckling), while raising the RH from 50% to 80% can actually cause the gesso layer to crack. Thus, the range of allowable RH fluctuation is more limited for the tangential direction than for the longitudinal direction. Nonetheless, from a starting point of 50% the RH can range downward to 28% or upward to 66% without causing the gesso to yield in the tangential direction. Even in this worst-case example, the gesso/wood composite can survive significant fluctuations in RH.

## The Paint Layers

To study stiffness, strength, and response to relative humidity fluctuations, mechanical tests were carried out on fifteen-year-old oil paints under true equilibrium conditions (several weeks of stress relaxation occurred prior to any subsequent incremental loading). Figure 11a, b shows the tensile test results for two of these paints. Although the yield points for nearly all the paints remained at about 0.004 throughout the tests, the breaking strains varied from one paint to another when tested at the same RH and temperature. For example, at 48% RH and 22 °C, flake white in safflower oil attained a breaking strain of 0.02 (Fig. 11a); titanium dioxide in safflower oil broke at 0.01 (Fig. 11b). When the same paints were tested at different relative humidities, it became apparent that RH plays a considerable role in modifying the mechanical properties. Flake white in safflower oil is a fairly flexible paint that was not seriously affected by the change in RH from 48% to 5% (Fig. 11a). Meanwhile, titanium dioxide in safflower oil lost nearly all its stiffness and strength when the RH was raised from 48% to 80% (Fig. 11b). In general, increasing the RH decreased the strength of a paint but increased its breaking strain, while lowering the RH increased its strength but lowered the breaking strain.

Typically, oil paints are far less dimensionally responsive to moisture than are hide glues or wood. Flake white in safflower oil, for instance, shows a total change in length of only about 0.5% when the RH is raised from 20% to 90%. A plot of the moisture coefficients of expansion (Fig. 12) demonstrates that this is one of the least dimensionally responsive materials presented in this discussion.

## Effects of solvents on paint

Leaching out the soluble components of oil paints has a dramatic effect on the mechanical properties. Two fifteen-year-old paints, cadmium yellow in safflower oil and cadmium yellow alkyd artist's paint, were soaked in toluene for a week, then allowed to dry for eight weeks. Figure 13a, b shows results of equilibrium tensile tests before and after toluene treatment for the oil and alkyd paints, respectively. Surprisingly, the yield points of the toluene-treated paints were no different than those for the untreated paints. After treatment, however, each paint experienced a

Figure 11a, b  
The equilibrium stress-strain plots at different environments for flake white (a) and titanium dioxide (b), both in safflower oil.

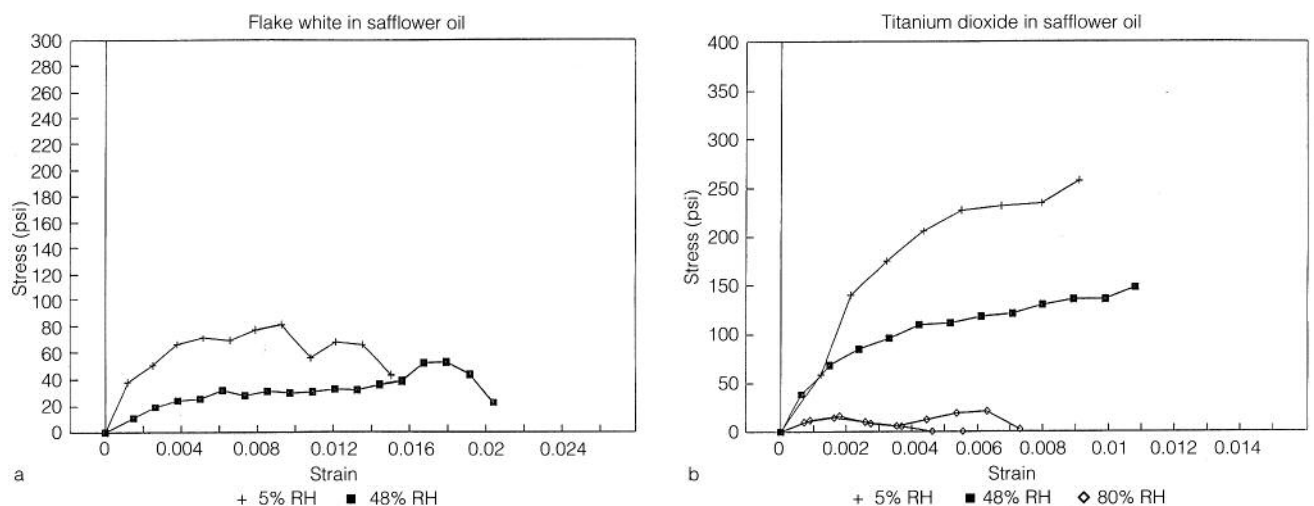

Figure 12

The moisture coefficients of expansion for flake white in safflower oil are the lowest of any included in this study.

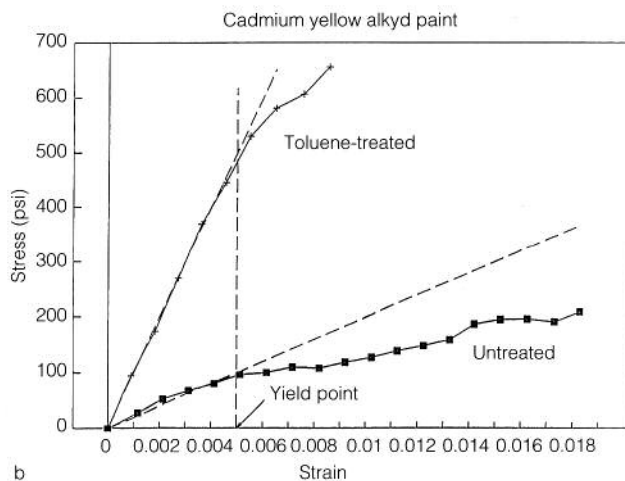
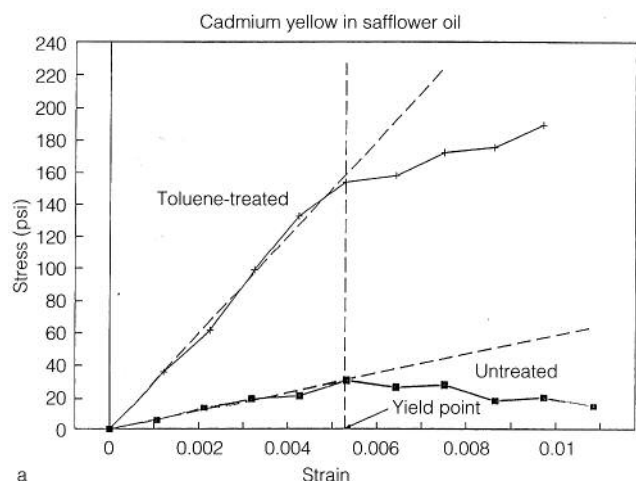
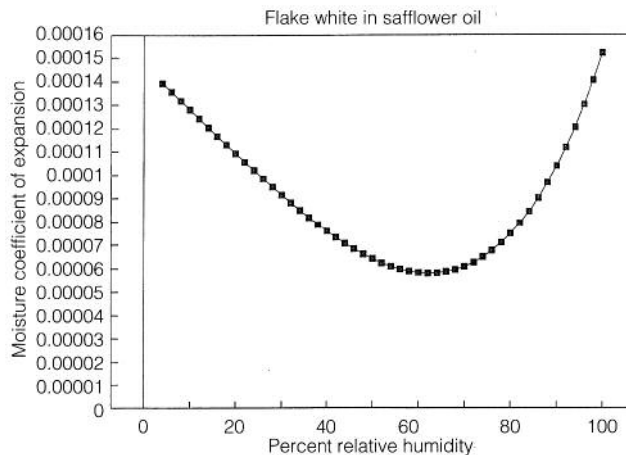

Figure 13a, b

The equilibrium stress-strain curves for cadmium yellow in safflower oil (a) and in alkyd (b), before and after soaking in toluene for one week.

fivefold increase in stiffness and at least a threefold to fourfold increase in strength. Obviously, the soluble components leached out by the toluene had been acting as plasticizers. Solvent leaching simulates one of the possible aging processes of oil paints that results in increased stiffness and strength: the slow evaporation of free fatty acids and other volatile, low molecular weight components (Michalski 1990; see also Erhardt herein).

There is no difference in the swelling characteristics of the treated and untreated paints. The moisture coefficients of expansion in treated oils and alkyds do not change from their untreated values (Fig. 14a, b).

Using the strain-to-yield values and integrating the expansion coefficients for the paints tested, it is possible to establish the allowable RH fluctuations for several restrained paints. Figure 14c shows the acceptable ranges for cadmium yellow in oil (toluene-treated and untreated), cadmium yellow in alkyd (treated and untreated), flake white in oil, and titanium dioxide in oil. Since the toluene treatment altered neither the yield points nor the expansion coefficients of the paints tested, the allowable RH fluctuations are no different for treated and untreated paints. The difference, if any, will be reflected in any changes in strain to break caused by the solvent.



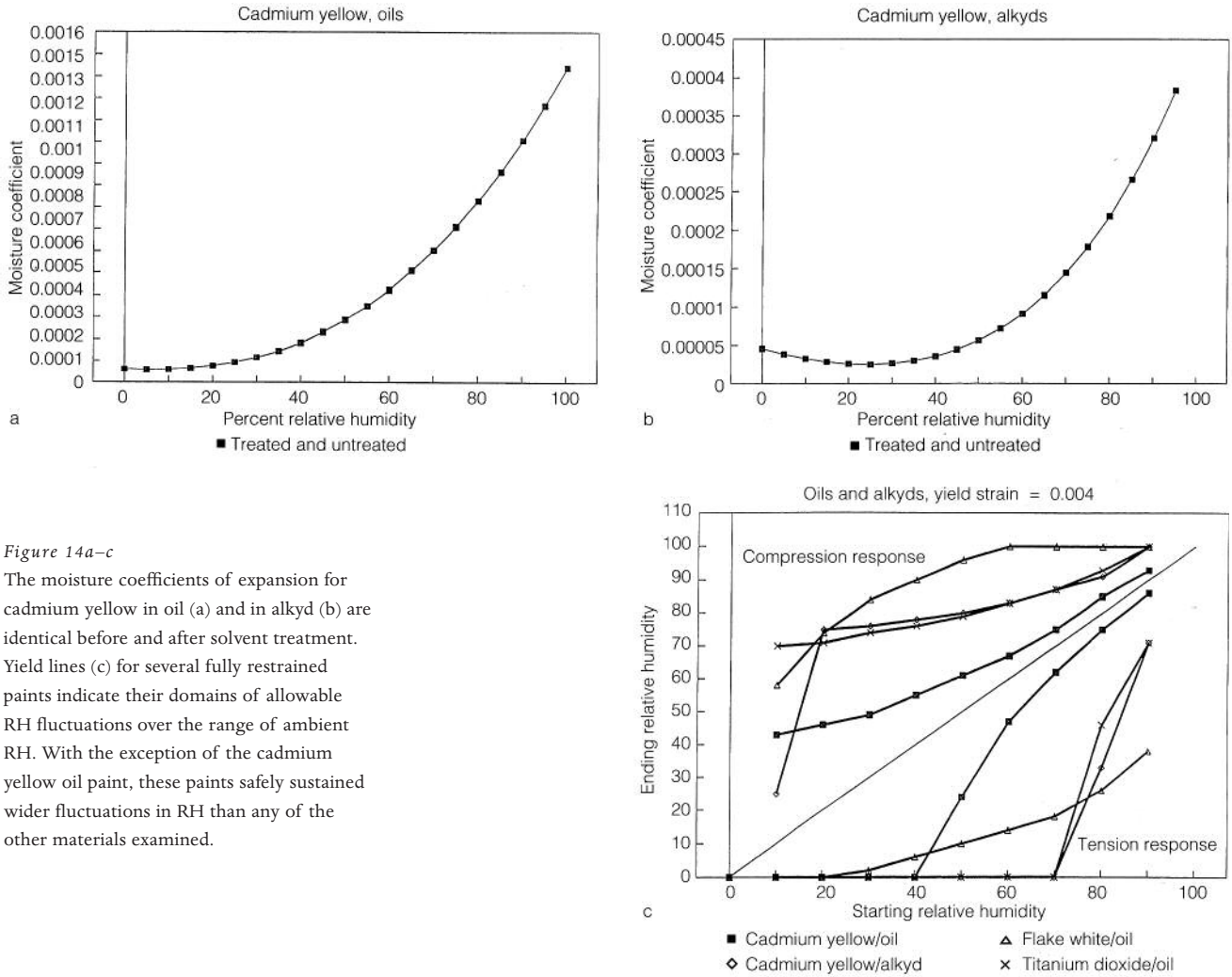

Figure 14a-c The moisture coefficients of expansion for cadmium yellow in oil (a) and in alkyd (b) are identical before and after solvent treatment. Yield lines (c) for several fully restrained paints indicate their domains of allowable RH fluctuations over the range of ambient RH. With the exception of the cadmium yellow oil paint, these paints safely sustained wider fluctuations in RH than any of the other materials examined.

### Response of a composite painted wood surface

For purposes of comparison, the moisture coefficients of expansion for cottonwood, hide glue, gesso, and flake white oil paint are plotted in Figure 15a. The very low coefficients of oil paint and gesso are almost identical, except the coefficients for gesso rise a bit in the range from 70% to 100% RH, while those for the paint stay nearly flat. As with the gesso, the paint—when applied to an unrestrained wood substrate—will experience a serious swelling mismatch outside of the midrange RH. This mismatch can be demonstrated by using equation 4 to calculate the strains expected in a composite of cottonwood, and flake white in oil. Figure 15b shows the flake white strains initialized at 50% RH. In the longitudinal direction, the allowable fluctuations for the paint are quite large. With desiccation from 50% RH, the RH can drop to about 10% before the paint reaches yield point. With humidification above 50%, the RH can rise safely to about 95% RH. In the tangential direction, desiccation to 26% RH will cause compression yielding; beyond that, buckling and cleavage can occur. Increasing the RH to 70% will cause yielding in tension, with possible cracking at extremely high RH levels.

## Flaking and the Adhesion of the Design Layers

Normally, the physical separation of the design layer from the support (i.e., peeling, curling, or flaking) manifests after a crack has occurred. There are occasions, however, when the paint layer separates from the wooden support without an associated crack. In art conservation this is usually referred to as *blind cleavage*, while the paint industry calls it *blistering* of the paint. On exterior painted wooden (and metal) surfaces, blistering may result from the solar heating of soft, freshly painted surfaces, from the penetration of excessive amounts of moisture, or from the generation of a gas beneath the paint layer (Hess 1965:102–4; *Wood Handbook* 1987:16–21; Houwink and Salomon 1967:51; Van Laar 1967). In all probability, poor preparation of the substrate also contributes to interlayer or blind cleavage caused by exposure to excessive moisture. Lean (insufficient glue) gesso grounds are particularly susceptible to blind cleavage because of the low cohesive and adhesive strength of the material.

A great number of causes have been proposed for the flaking of a previously cracked paint film. Exterior paints may flake because of exposure to frequent cycles of wetting (by rain) and drying. Too little oil binder may cause poor adhesion of the paint, as may contamination of the prepared surface with dirt, wax, fats, nondrying oils, or grease. Cold temperatures may also cause flaking. As Hess states (1965:242):

It is widely known that elasticity, adhesion, and shock resistance of most paints and varnishes, even those of very long-oil length, suffer badly during cold weather. The temperature need not necessarily be below freezing point and susceptibility already exists for some coatings at about 50 °F (10 °C). As long as the films are on rigid structures and do not crack the failure does not become permanent and is hardly apparent at all.

Figure 15a, b

A comparison of the moisture coefficients of expansion (a) of cottonwood, gesso, hide glue, and flake white oil paint. Equation 4 was used to determine the strain interactions (b) of flake white in oil and its cottonwood substrate in fluctuations above and below an ambient RH of 50%. At extreme low RH, the paint endures simultaneous compressive strain in the wood's tangential direction and tensile strain in the longitudinal direction. These strains are reversed at extreme high RH.

Certain woods accept and hold paint better than others. Cedar, cypress, and redwood are excellent woods for painting, while red and white oak, elm, chestnut, and butternut are considered poor choices. In fact, many of the woods historically used as paint substrates for art objects, such as cottonwood, basswood, and yellow-poplar, are not recommended as suitable for exterior painted finishes in the *Wood Handbook* (1987:16–21), one of the standard industrial texts. One of the factors affecting the permanence of a painted surface is moisture-related dimen-

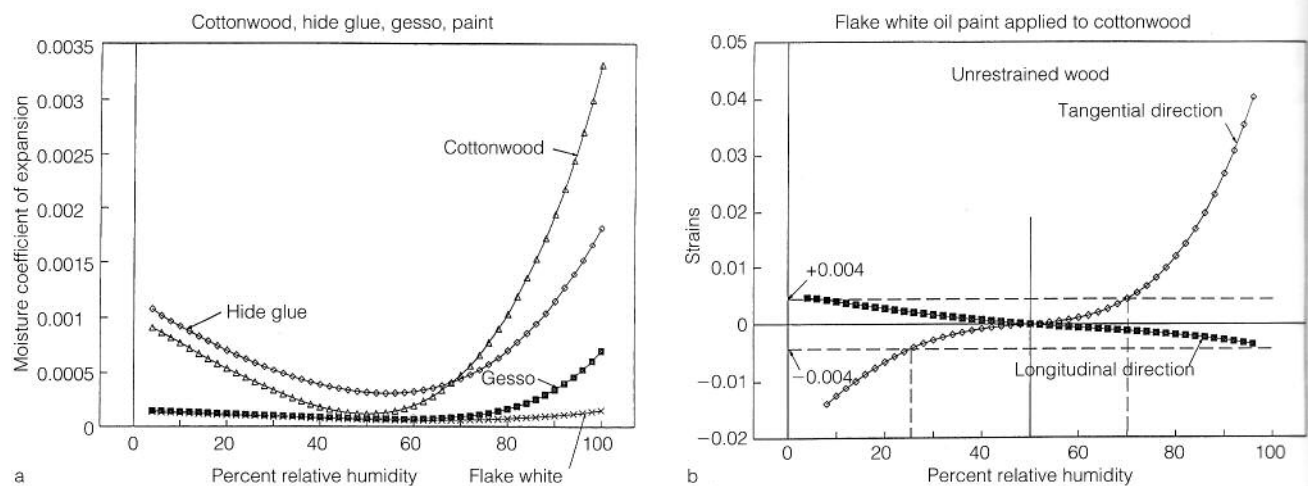

sional stability, and woods that retain paint well tend to be the most dimensionally stable. Obviously, this is the reason radially sawn boards hold paint better than tangentially sawn boards. Other than dimensional stability, density seems to be the chief factor in wood's ability to retain paint, with less dense (more porous) woods likely to be better paint substrates. This explains the tendency for paint to adhere better to earlywood in species with pronounced earlywood-latewood differences; the lower density and greater porosity of the earlywood helps it to retain paint (Marian 1967). This correlation of wood density with paint adhesion suggests that the wood-paint bond is largely mechanical.

Nonetheless, there are convincing arguments that van der Waals forces contribute significantly to the adhesion of paints to wood (Marra 1980; Salomon 1967; Kaelble 1971:45–82; Pocius 1986; Parker and Taylor 1966). Current theory suggests that the adhesion mechanisms are a combination of chemical bonding and mechanical attachment. While increasing the porosity (or surface texture) of a substrate may encourage a better mechanical grip, it is also true that more chemical bonding sites are exposed. Whether or not the adhesion is mechanical or chemical, both bonding mechanisms are seriously affected by wood's affinity for water. While moisture can seriously affect an existing paint-wood bond line, fracture testing of bonded joints suggests that the presence of moisture in the wood at the time of paint application can also seriously weaken the resulting bond (Kousky 1980).

Moisture represents one of the most important factors in the delamination of a paint film, glue size, or gesso ground. High moisture content disrupts the adhesion bond, and subsequent desiccation separates the materials physically. High moisture content in wood can result from liquid sources such as rain, condensation on walls, or groundwater from wet foundations. It may also result from a vapor source (persistent high relative humidity).

---

## Conclusion

Fluctuations in relative humidity cause strains in the materials used to construct a cultural object. Quantifying the moisture response of each of the materials permits one to determine the allowable RH fluctuations—the RH changes an object can safely endure. In the example presented in this study (a painted panel composed of cottonwood, hide glue, gesso, and oil paint), several conditions were examined to assess the RH-related behavior. Theoretically, the hide glue size was found to be the material limiting the allowable RH fluctuations of the panel. Because of its low yield point and its great capacity for expansion in response to moisture, the glue should limit the panel to an allowable RH fluctuation of  $50\% \pm 11\%$ . Because glue stresses relax over time, however, the glue actually has little influence on the overall response of the panel.

The maximum allowable RH fluctuation for a particular object is ultimately determined by examining the independent RH response of each of the materials making up an object, determining the effects of the composite nature of the object on each material's response, then adopting the composite worst-case responses as the factors that truly limit the allowable RH fluctuations. Assuming that an ambient RH of 50% is desirable, the painted panel can endure maximum allowable RH fluctuations of 16% above 50% RH (the tension yield point for the tangential wood substrate)

and 22% below 50% RH (the compression yield point for gesso in the wood's tangential direction). As a structure, then, the panel may endure considerable fluctuations in the environment.

Equally important, the research shows the *type* of damage most likely to occur, given a particular set of circumstances. For example, cracking is most likely in the gesso and paint layers when a panel is expanding in response to a severe increase in RH. These cracks will run parallel to the grain of the substrate (longitudinally). Cracking might also occur in the gesso and paint under extreme desiccation, but these cracks will run perpendicular to the grain of the substrate (across the grain). During severe desiccation, the gesso and paint layers may even suffer compression cleavage and ridging, but the ridges will invariably run parallel to the substrate's grain.

The research also shows that if a painted panel becomes equilibrated at an extreme high or low RH, it cannot be returned to the moderate RH regions without damage. This is because the domain of allowable RH fluctuation narrows at extreme high or low levels of ambient RH, permitting very little RH change without yielding and failure.

From the standpoint of structural stability, the optimal environmental baseline for most objects is in the middle RH region (45% to 55%), since nearly all materials experience their lowest rates of RH-induced dimensional response (i.e., their lowest moisture coefficients of expansion) in this region.

---

## Note

- 1 Because the authors' tests were performed in pounds per square inch and the graphs provide data in the same units of measure, conversions to kilograms per square centimeter were not done.

---

## References

- Doerner, M.  
1962 *The Materials of the Artists and Their Use in Paintings . . . With Notes on the Techniques of the Old Masters*. New York: Harcourt, Brace, and World.
- Hess, M.  
1965 *Paint Film Defects*. 2d ed. New York: Reinhold.
- Houwink, R., and G. Salomon, eds.  
1967 *Adhesion and Adhesives*. Vol. 2. Amsterdam, N.Y.: Elsevier.
- Kaelble, D. H.  
1971 *Physical Chemistry of Adhesion*. New York: Wiley-Interscience.
- Kousky, J. A.  
1980 Recent results on fracture toughness of bonded wood. *Proceedings of 1980 Symposium, Wood Adhesives—Research, Application, and Needs*, 189–94. Madison, Wis.: U.S. Forest Products Laboratory.
- Marian, J. E.  
1967 Wood, reconstituted wood and glue laminated structures. In *Adhesion and Adhesives*, vol. 2, ed. R. Houwink and G. Salomon, 167–70. Amsterdam, N.Y.: Elsevier.
- Marra, G. G.  
1980 The role of adhesion and adhesives in the wood products industry. In *Proceedings of 1980 Symposium, Wood Adhesives—Research, Application, and Needs*, 1–8. Madison, Wis.: U.S. Forest Products Laboratory.

- Mecklenburg, M. F., and C. S. Tumosa  
 1991 Mechanical behavior of paintings subjected to changes in temperature and relative humidity. In *Art in Transit: Studies in the Transport of Paintings*, ed. M. F. Mecklenburg, 173–216. Washington, D.C.: National Gallery of Art.
- Mecklenburg, M. F., C. S. Tumosa, and M. H. McCormick-Goodhart  
 1995 A general model relating externally applied forces to environmentally induced stresses in materials. In *Materials Issues in Art and Archaeology IV, Materials Research Society Symposium Proceedings*, vol. 352, 285–92. Pittsburgh, Pa.: Materials Research Society.
- Michalski, S.  
 1990 A physical model of the cleaning of paint. In *Cleaning, Retouching and Coatings: Preprints of the Contributions to the Brussels Congress, 3–7 September 1990*, ed. J. S. Mills and P. Smith., 85–91. London: International Institute for Conservation of Historic and Artistic Works.
- Parker, R. S. R., and P. Taylor  
 1966 *Adhesion and Adhesives*. Oxford, N.Y.: Pergamon Press.
- Pocius, A. V.  
 1986 Fundamentals of structural adhesive bonding. In *Structural Adhesives, Chemistry and Technology*, 33–75. New York and London: Plenum Press.
- Salomon, G.  
 1967 Adhesion. In *Adhesion and Adhesives*, vol. 1, ed. R. Houwink and G. Salomon, 1–128. Amsterdam, N.Y.: Elsevier Publishing.
- Van Laar, J. A. W.  
 1967 Adhesion and paint technology. In *Adhesion and Adhesives*, vol. 2, ed. R. Houwink and G. Salomon, 459–64. Amsterdam, N.Y.: Elsevier.
- Wood Handbook: Wood as an Engineering Material*  
 1974 Agricultural Handbook No. 72. Madison, Wis.: Forest Products Laboratory, U.S.D.A.  
 1987 Agricultural Handbook No. 72. Madison, Wis.: Forest Products Laboratory, U.S.D.A.

# Factors Affecting the Re-Treatment of Previously Consolidated Matte Painted Wooden Objects

*Eric F. Hansen and Mitchell Hearn's Bishop*

**C**ONSOLIDATING POROUS, FRAGILE MATTE PAINT without affecting the appearance of an object is considered by ethnographic conservators to be one of the most challenging conservation treatments. Today, due to a greater knowledge of preventive conservation and an increasing consideration of ethical issues, consolidation treatments are not so readily or routinely attempted as in the past. But many objects have been treated in the past, and conservators are often required to re-treat them. This chapter considers some factors affecting the choice of procedures and materials for re-treatment of painted wood objects in which a previous consolidation treatment produced an undesirable change in appearance or insufficiently strong consolidation.

This discussion is based on the authors' previous reviews and evaluations of treatment methods and materials. One major difficulty encountered is ascertaining what materials and methods have been used in prior conservation treatments, due in a large part to a lack of documentation. Therefore, another purpose of this chapter is to emphasize the need for a comprehensive history of the materials used in the consolidation of painted objects.

---

## Matte, Porous Paint and Its Treatment

Some research conducted at the Getty Conservation Institute over the past five years has focused on the problems associated with the consolidation of painted wooden ethnographic objects, particularly those with matte, friable surfaces. A number of studies conducted in support of this research have been published (Hansen, Sadoff, and Lowinger 1990; Hansen et al. 1993; Hansen, Lowinger, and Sadoff 1993; Hansen and Volent 1994), along with a topical review and an extensive annotated bibliography (Hansen, Walston, and Bishop 1993) published as a special supplement to volume 30 of *Art and Archaeology Technical Abstracts (AATA)*. The topical review, presented as an introduction to the AATA supplemental bibliography, includes an overview of the historical occurrence and the variety of technologies and materials used in the production of matte, porous paint, along with a discussion of analytical methods useful for the identification of the range of organic binders.

Matte, porous paint can be found on wooden objects in a wide variety of cultural contexts. This type of paint is ubiquitous in indigenous painted wooden objects from Oceania, Africa, and the Americas, including bark paintings of Australian Aborigines, masks and sculpted figures from

Africa, and painted objects from the American Southwest (such as kachina dolls). Inorganic pigments, such as red iron oxide, yellow iron oxide, calcium carbonate, and various black minerals predominate, and charcoal also was readily available as a black colorant.

Although the color palette is somewhat restricted in many examples of ethnographic painted wood objects, a plethora of organic binders is encountered due to the general use of locally available plants or animals. Thus, the types of binders encountered reflect the geographic and temporal variation of plant and animal species. Binders that have been cited repeatedly include acacia gum, pine resins, orchid juice, and animal glue (Hansen, Walston, and Bishop 1993:xix–xx).

The emphasis of this overview of matte paint requiring consolidation centered on ethnographic and archaeological objects because of the frequency with which their paint problems have been reported in the literature; however, similar problems are also found with matte paints used in architecture, folk art, modern and contemporary art, and many other forms of applied art. Some outstanding examples are Netherlandish Tüchlein distemper paintings and medieval German panel paintings, illuminated manuscripts, North American Colonial period house paints, and nineteenth- and early-twentieth-century pastel drawings.

It is interesting to note that in the first three of this last set of examples matte paint requiring consolidation can be associated with the historic use of proteinaceous binders such as animal glue (gelatin). More recently, problematic matte paint requiring consolidation is seen to be the result of the formulation of paint with an unusually low ratio of the volume of a synthetic polymer binder—such as poly(vinyl acetate)—to the volume of pigment in order to achieve a matte surface for a particular aesthetic effect. Examples are works by artists such as Yves Klein, Mark Rothko, Barnett Newman, and Ed Ruscha (Hansen, Walston, and Bishop 1993:xxvii–xxviii).

However, the primary purpose of the topical review was to assess current information on the properties of paint that is in need of consolidation and to explain how such information might be used to develop treatment strategies. The following is a brief summary of the authors' findings on the reasons for the "success" or "failure" of consolidation treatments in adequately consolidating paint while minimizing changes in appearance. It serves as an introduction to the focus of this article: factors to be considered in the re-treatment of paint whose previous consolidation altered the appearance to an unacceptable degree or failed to obtain cohesion of the paint and adhesion of the paint layer to the substrate (in this case, wood).

The friable or flaking porous condition of a painted surface is often due to an insufficient amount of binder in the paint formulation, whether from an intentional or unintentional act on the part of the artist or artisan. Paints with a high ratio of pigment to binder are described in the coating industry as a "high pigment volume concentration coating." For the purposes of this discussion, high pigment volume concentration paints have two important properties: low strength and extendability; and low gloss (a light, matte color). When a consolidant is introduced in the usual manner, through spray or brush application of a solution, void spaces are filled. While filling of void spaces binds pigment particles together, this may also result in a reduction of scattered light from air-pigment interfaces, which causes darkening. If there are localized high concentrations of consolidant at the surface, there may also be an

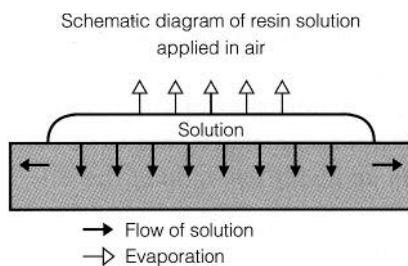

Figure 1  
 Schematic diagram of resin solution applied in air. The direction of solution flow is indicated by the solid black arrows; evaporation is indicated by the open arrows (after Hansen, Lowinger, and Sadoff 1993).

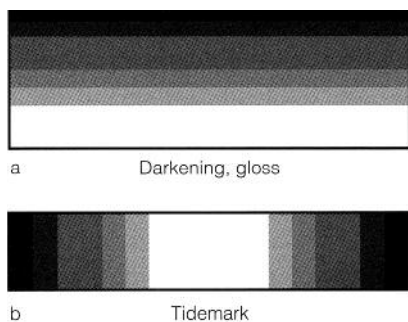

Figure 2a–b  
 Possible concentration profiles of resin solution applied in air, shown in cross section; darker areas indicate relatively higher concentrations of resin (after Hansen, Lowinger, and Sadoff 1993).

increase in the gloss. Additionally, noticeable *tidemarks* may appear at the edge where a consolidant solution flowed, if the entire surface has not been covered.

The aim, therefore, when consolidating porous, matte paint, is to use a consolidation system that distributes the consolidant in a manner that minimizes changes in appearance by introducing the minimum quantity necessary to achieve effective cohesion of the paint and adhesion of the paint to the substrate, while maintaining long-term compatibility with the paint and support materials.

Two distinct classes of paint have been previously considered: powdering porous paint, and flaking porous paint. In the case of flaking porous paint, consolidants used to adhere flakes may wick into the flakes and cause darkening. In the AATA topical review, a schematic arrangement of possible treatment options was split into two categories based on their utility in consolidating a particular paint type (Hansen, Walston, and Bishop 1993:xlvi). The primary strategy employed for the first category—powdering paint—is to use various methods to maintain a low viscosity of the consolidant solution as a means of maximizing penetration and equal distribution. (This may be achieved by means of low volatility solvents, suppression of solvent volatility, or multiple applications of dilute solutions.) The primary strategy employed for the second category—flaking porous paint—is to use various methods that minimize penetration into a flake by an adhesive. (Methods include highly viscous solutions, spray techniques, and pretreatment with solvents immiscible with the consolidant solution.) Another strategy employed for both types of paint is to use methods that discourage leveling of the consolidant solutions, and thus promote conformity of the solid consolidant on the surface to the roughness of the paint film.

Thus, for high pigment volume concentration paint, “successful” treatment options are those that achieve the desired distribution of a consolidant. “Unsuccessful” treatment options are those that create unfavorable resin distribution and placement within the paint layer, which causes darkening, the formation of *tidemarks*, or insufficient cohesion of the pigment particles and poor adhesion to the substrate.

Figure 1 illustrates the flow of a solution into a paint layer, shown in cross section, while solvent is simultaneously evaporating from the surface. Because the concentration of the solution flowing into the paint increases with time as the solvent evaporates, the final consolidant concentration (a darker area indicates a greater concentration of resin) may be greater at the surface (Fig. 2a), causing darkening, possibly increased gloss, and low concentrations at the substrate-paint interface. By contrast, *tidemarks* may result from deposition of materials originating from solubilization of resins in the wood, from dirt or products of biodeterioration, or from the physical redistribution of pigment particles (particularly when there is a large particle size distribution) as a result of solution flow. However, *tidemarks* may also result from the deposition of consolidant. As a solution flows outward from its applied area, solvent is evaporating, increasing the concentration and viscosity of the solution with time. The result may be a resin distribution (Fig. 2b), where greater concentrations of resin at the edge result in darkening from greater filling of void spaces or from changes in surface reflection.<sup>1</sup>



## General Considerations in Re-Treatment

As stated earlier, the primary reason for re-treatment is that previous consolidation treatment(s) (1) resulted in an unacceptable change of the surface of the painted object (i.e., the surface was originally lighter and more matte but is now darker, grayer, or glossier); (2) failed to impart the required strength of cohesion and adhesion to prevent further paint loss; or (3) failed in both respects. The specific aim of re-treatment of matte paint is to minimize change in the original appearance of the object and to stabilize a now unstable or deteriorating surface. Although the ethical goal of using reversible treatments may have little practical applicability, the use of materials and procedures that are amenable to future manipulations (such as future solubility), whether applied in the past or in use today, allow for the possibility of re-treatment.<sup>2</sup>

Differences in the reflection of light between surfaces must be avoided if treated and untreated areas are to match in appearance. This phenomenon (which has long been recognized in the coatings industry), where two colors appear to match at one angle but no longer match if the viewing angle is changed, is termed *geometric metamerism* (Johnston 1967). The diagram of geometric metamerism reproduced in Figure 3 shows the effect of pigment protruding from a film on the scattering of light, and it explains why in some instances a tidemark can be detected only by rotating the plane of the paint in relation to the eye. Therefore, a further treatment, or re-treatment, that either removes excess consolidant from the surface of the paint layer or (as is generally more practical for the systems discussed) redistributes a consolidant into the desired concentration throughout the paint layer will minimize discoloration and increase cohesion and adhesion.

The most important factors affecting re-treatment of matte painted wood objects are

1. the chemical and physical nature of the consolidant, which either promotes or discourages solubilization and redistribution in the future;
2. the parameters of methods for solubilizing previous consolidants to allow removal or redistribution without disrupting or damaging a fragile paint layer;

Figure 3  
Geometric metamerism (after Johnston 1967).  
The colors of a and b will appear to match.  
The colors of c and d will be different.

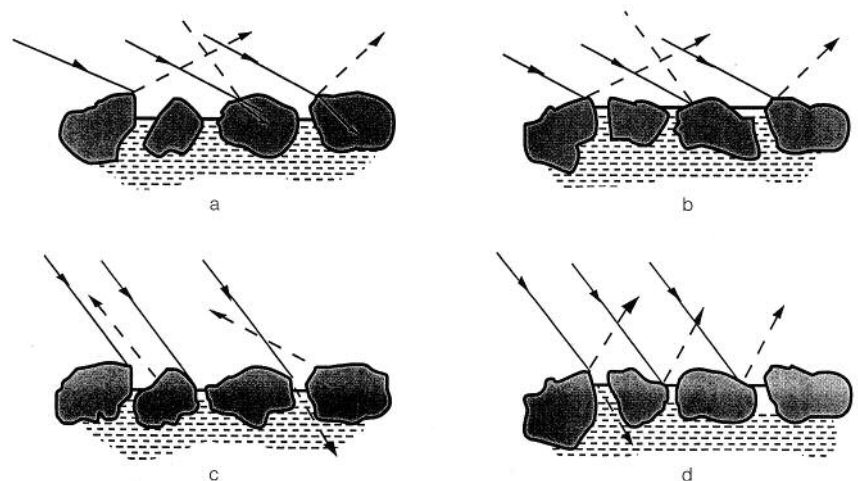

3. the condition of the wood substrate and possible ground layer(s), and the potential effect of added solvents and materials upon the substrate and ground (both immediately and in the long run).

Evaluation of these three factors requires knowledge of past treatment—in particular, the materials used and their aging properties.

In reference to the wood substrate, it may be quite deteriorated and may have been previously consolidated prior to, or during, the consolidation of the paint. One must also consider the effects of solvents (used to deliver the consolidant) on the wood, as well as the penetration of the consolidant solution (and therefore added resin to the wood), resulting both from the original treatment(s) and from subsequent corrective re-treatment.

---

## Conservation Materials

### Identification of methods and materials used in previous treatments

When re-treating an object, an attempt is made to determine what substances may have been applied in the previous treatment. If some form of treatment documentation exists, it may be possible to find the information. Unfortunately, this is rarely the case for early treatments. If any documentation on previous treatments does exist, it may not be accessible to the conservator, or it may be sketchy and inadequate since it may date to a period prior to the codification of conservation documentation.

When it is not possible to find documentation of previous conservation materials and application methods, two alternatives for identification may be used. The first is the analytical approach. A number of methods ranging from optical microscopy to chromatographic techniques and a variety of instrumental methods may be used to determine what materials may have been applied. These analyses can be strengthened by a knowledge of materials that were *likely* to have been used during a given time period.

If no conservation documentation exists, literature from a given period can give some idea of the methods and materials that were in use. Until a definitive work on the history of conservation materials is published, it will be necessary to rely on literature such as published conservation texts and articles from the relevant period. Some of this information can be found in *Materials for Conservation* (Horie 1990) and in compilations such as *Early Advances in Conservation* (Daniels 1988). *Dégradation, conservation et restauration de l'oeuvre d'art* (Marijnissen 1967) contains an important and extensive discussion of the history of conservation that has been cited by others (Keck 1977; Keck 1984), but it has yet to be translated into English. Further sources include oral histories (such as those found in the Foundation of the American Institute for Conservation Archives or the Archives of American Art of the Smithsonian Institution).

A systematic review of materials cited in early treatises, works on artists' techniques, and early conservation literature waits to be undertaken, along with a consideration of the dates that many of the synthetic polymers were likely to have been introduced into conservation. For example, it is possible to make a comparison between the methods and materials advocated by Alfred Lucas in his publications, and the actual treatment

documentation for the objects from Tutankhamen's tomb that were treated in the late 1920s. In *Antiques: Their Restoration and Preservation* (1924), Lucas describes the preparation of conservation materials he recommends. He suggests three materials for consolidation: paraffin wax, a solution of celluloid in amyl acetate or acetone, and a solution of cellulose acetate in acetone. He proposes the use of a spray atomizer or a camel-hair brush for application. Lucas also suggests a re-forming technique in the following remarks in a reference to the treatment of "black lacquer" Egyptian wooden funerary objects (1924:96):

This is not a paint, but a kind of varnish, consisting of a natural black resin of a lacquer-like character, such as is found and used in India, China and Japan at the present day. . . . [B]eing a resin it is soluble in alcohol and acetone, and if sprayed with either of these solvents, should it show signs of flaking off, it softens at the edges and adheres again. The spraying makes the surface very glossy, but in many instances this was the original appearance.

Reference to the actual treatment records left by Lucas verifies that in fact consolidants used on painted wood objects from Tutankhamen's tomb did involve paraffin wax, celluloid solution in amyl acetate, celluloid solution in acetone, cellulose acetate in amyl acetate and acetone, and cellulose acetate in acetone (Piqué 1994). Methods of application involved pouring of the melted paraffin wax, and spraying and brushing on of the celluloid and cellulose acetate solutions. Such information should be confirmed whenever possible by analytical means before proceeding with a re-treatment program because many objects (especially those judged the most important objects in a collection) may have been given multiple treatments.

### Aging and solubility of conservation materials

An abbreviated list of materials used for the consolidation of paint in the twentieth century is given in Table 1, roughly in order of their introduction. Of primary importance for this discussion is the stability of the

Table 1 Materials used for the consolidation of paint on objects

Wax
Natural products (drying oils, gums)
Gelatin
Cellulose nitrate
Cellulose acetate
Poly(vinyl acetate)
Poly(methyl methacrylate)
Poly(vinyl alcohol)
Poly(butyl methacrylate)
Acryloid B72
Poly(vinyl butyral)
Soluble nylon
Cellulose ethers
Thermosetting polymers (e.g., epoxies)

---

materials in reference to environmentally introduced chemical modifications that decrease solubility, such as cross-linking of polymer chains. Arguably, the most stable synthetic polymers are poly(vinyl acetates), poly(methyl methacrylate), and Acryloid B72 (an acrylic copolymer), when they are supplied as a solid resin alone or dissolved in an organic solvent. (These materials may be supplied in the form of aqueous emulsions formulated with a variety of additives; in some cases, they may have undesirable aging properties, as well as often undesirable working properties.) Paraffin wax—as opposed to a variety of plant and animal waxes processed by various methods—is also relatively resistant to oxidation; therefore, painted objects previously treated with wax might be re-treatable (although wax introduces several other problems, discussed below, that may render it inappropriate for use as a consolidant).

Paint consolidated with such materials may possibly be re-treated by removal or redistribution. However, less stable materials, such as butyl methacrylate or cellulose nitrate, offer less possibility for re-treatment, depending on the severity of environmental extremes to which the consolidated objects have been exposed and the length of time that has lapsed since consolidation.

Of particular interest—and the point of this discussion—is the fact that a greater potential exists for the re-treatment of some objects treated with materials in very early time periods—for example, objects treated with poly(vinyl acetates) in the late 1930s and 1940s, or even with paraffin wax in the 1920s—than for objects treated with some of the materials introduced later—especially those consolidated in the 1960s and 1970s with soluble nylon or poly(vinyl acetate) and poly(vinyl alcohol) emulsions.

The authors have previously discussed the possibility of using thermosetting polymers in low concentrations to consolidate matte paint, based on the consideration that greater strength of consolidation could be gained by introducing smaller amounts of thermosetting resins (such as epoxies) than with thermoplastic resins, thus minimizing the potential for undesirable changes in appearance (Hansen and Agnew 1990). Additionally, it has often been considered that the solubility characteristics of aged material are of little relevance because of the very unlikely chance that a material could be removed in the future from a very fragile surface such as porous, powdering paint (Horton-James, Walston, and Zounis 1991). In light of the factors affecting re-treatment presented here, the use of thermosetting polymers should be more carefully reviewed, along with the argument that future solubility of consolidation materials is not an important working consideration.

---

## Re-Treatment of Wood

One of the most common early treatments for consolidating painted wood objects, particularly when the wood itself was in need of consolidation, was the application of, or immersion in, molten wax (Rosen 1950). Hatchfield and Koestler (1987) used scanning electron microscopy to evaluate the microstructural appearance of archaeological wood that had been subjected to consolidation with wax, followed by subsequent removal of wax, and then a further consolidation with an acrylic resin. It was found that, even though wax removal was incomplete after successive immersions in toluene, subsequent consolidation by the addition of an acrylic resin in toluene resulted in improved strength and appearance of the

wood. When a similar wood was consolidated with the acrylic resin alone, subsequent removal of the acrylic resin by solvent immersion was more complete but appeared to cause more damage. In fact, the greatest damage was observed when the wood was immersed solely in toluene without any consolidation treatment.

This study not only illustrates the possibility for re-treating painted wood objects originally treated with wax, but also suggests that residual amounts of a consolidant may reduce the amount of disruption to a fragile surface when it is re-treated, while still allowing for the introduction of a new consolidant. The presence of paint on wood considerably complicates the problems associated with consolidation, particularly when it is necessary to find a consolidant procedure or procedures for both wood and paint (systems that differ both in respect to their structure and to the materials present). Even when the wood substrate does not necessarily need consolidation, one must consider the possible effect on the wood when the paint is consolidated. The creation of a barrier coating through consolidation of the paint might affect the equilibrated moisture content of the wood at different relative humidities (i.e., a change in the dimensional response of the wood substrate with fluctuations in relative humidity might affect flaking or loss of adhesion—particularly in respect to adjacent treated and untreated areas). However, this may be of little concern because, by definition, successful treatments introduce the smallest possible amount of material, leaving the porous paint as close to the original porosity as possible to retain the object's initial appearance.

One further factor to be considered is resin migration in wood that has been treated with a consolidant. Schniewind and Eastman (1994) found that samples of wood that had been completely saturated with a consolidant by an immersion treatment subsequently had an uneven distribution of the consolidant when dry, with some indication of a tendency to increase concentration toward the end surfaces as a result of migration of the consolidant resin with solvent evaporation. As previously mentioned, the authors have not found reverse migration to be a viable phenomenon in highly porous or powdering paint; rather, the localized surface concentrations in the paint layer are the result of lack of penetration due to solvent loss through evaporation. However, the dynamics of distribution of the consolidant in the wood substrate as a result of penetration into the wood by the consolidant used for the paint, and the subsequent evaporation of solvent through the porous paint, are not as well understood. Hence, questions persist as to how the consolidant remains distributed in the wood, and what effects this might have on the wood substrate (both in relation to the original consolidation treatment and to subsequent re-treatment methods, including those for removal, redistribution, or reintroduction of consolidants).

---

### Examples of Removal or Redistribution of a Previously Applied Consolidant

#### Removal of an unwanted varnish layer on matte paint

One successful re-treatment involved the removal of an undesired coating (originally applied as varnish layers) from an easel painting that was in such a fragile state that a preconsolidation treatment was required. The varnish had added undesired gloss and darkening to the originally matte surface, and a new consolidant was added to stabilize the fragile, porous

paint layer, allowing removal of a previous consolidant. Although on first consideration this example of the conservation of an easel painting may seem to be somewhat removed from the problems associated with painted wood, it should be stressed that very few treatments of paint on any substrate to remove past materials specifically to return the surface to a matte appearance are known to the authors. Of particular interest is the newly developed technique of using solvent gels to clean painted surfaces. These methods may have potential for the removal of unwanted consolidants from the paint on wood surfaces.

*The Adoration of the Magi*, attributed to Andrea Mategna (active in the fifteenth century), is in the collection of the J. Paul Getty Museum. In the Tüchlein technique, the medium is distemper (glue based) and results in a lucid, matte surface that was the desired aesthetic intention, as opposed to that later associated with the more saturated and glossy surface of drying-oil paints that were subsequently varnished. Over the centuries, layers of grime had built up on the thin and very porous paint surface. Varnishing to revive the surface had resulted in further darkening. The purpose of the conservation treatment was to remove the varnish, as well as the grime, and not to revarnish the painting (Rothe 1992:85).

The paint—which was porous, fragile, and showed lifting of numerous small flakes—was first consolidated with several applications of dilute aqueous gelatin solutions. All attempts to remove the varnish with organic solvent mixtures produced extensive blanching. However, preliminary tests with solvent gel formulations and procedures developed by Richard Wolbers of the University of Delaware/Winterthur Museum Art Conservation Program specifically for this application allowed varnish removal without blanching (Rothe 1994). These particular solvent gels were formulated with polymers of acrylic acid that can be used to thicken both aqueous and organic solvent solutions. Gelled solutions can be used to control solvent evaporation rate, extend contact time with the surface, and, to some extent, control the degree that a solution permeates into a surface.<sup>3</sup> Two solvent gel formulations were used: one formulated with acetone, water, and benzyl alcohol, and another with ethanol, xylene, water, and Triton X-100, in addition to the thickening agent. The gels were removed with Shellsol 71 (now called Shell Odorless Mineral Spirits) after application to one small section of the painting at a time. The majority (but not all) of the varnish could be removed from the entire surface in this manner.

Thus, not only in principle but in practice, it is possible in some instances to remove an unwanted consolidant from a fragile paint layer. In this case, the varnish had penetrated into the porous paint and was not completely removed because a satisfactory appearance had been achieved. The formulations of the solvent gels are mentioned not to suggest any recipe for removal of commonly encountered picture varnishes, such as dammar or mastic, but rather to underscore the fact that the blanching associated with organic solvents was diminished, presumably because the penetration of the solution into the paint was reduced. Solvent gels may be effective in the removal of any number of synthetic and natural products due to the wide choice of applicable solvents. Additionally, this example may be of interest to some ethnographic conservators in Europe, where, although the practice of using natural products such as dammar to consolidate paint is rarely encountered today, such was not the case in the past few decades (Hansen, Walston, and Bishop 1993:lvii).

Achieving satisfactory results in the removal of varnish from matte paint requires an inordinate amount of skill and experience on the part of the conservator, specifically in regard to avoiding effects such as geometric metamerism of successively treated adjacent areas of the paint (as shown in Figure 3, where a similar appearance of two paints is shown to be dependent on a similar depth of protrusion of pigment particles from the paint surfaces).

Regarding the use of solvent gels, some concern has been raised that the gels are either not totally effective against capillary action—allowing moisture penetration through cracks and into size layers (Southall 1989)—or (in the case of aqueous systems, such as resin soaps) that the residues of nonvolatile components may affect properties of paint films, such as oil paints (Erhardt and Bischoff 1993).

As stated earlier, a great majority of matte painted wood objects are ethnographic objects from Oceania (including Australia) and Africa that are executed with little paint binder and in which the use of a limited palette of inorganic pigments (particularly red and yellow iron oxide) was extensive. In many instances, there may be little potential for problems associated with the use of solvent gels or resin soaps in the re-treatment of ethnographic objects, particularly if the paint can be treated with a consolidant (such as gelatin) prior to attempts at removing a resin. However, because ethnographic objects are often produced using locally available colorants and binders, the diversity of materials encountered can be much greater than that usually found in traditional Western easel paintings. In such cases, the potential for interaction effects might increase.

### Redistribution of a previously applied consolidant

The second example is that of the successful redistribution of a consolidant that had caused darkening of a light, fragile matte paint layer (formulated without the addition of a binder) when originally applied. As stated in the previous example, reasons for paint discoloration may be the uneven distribution of resin. Localized surface concentrations may add gloss or fill void spaces, causing darkening. Localized concentrations may also define the extent to which a solution flowed over and through the paint, appearing as tidemarks. Therefore, re-treatment methods that successfully redistribute the consolidant may reduce these changes in appearance, while still maintaining sufficient cohesion of the paint and adhesion to a substrate, or even improving the cohesion and adhesion.

Hansen, Lowinger, and Sadoff (1993) treated a number of wood blocks, which were painted with red iron oxide and yellow iron oxide on a white kaolin ground, in two different ways: in an atmosphere open to the environment, and in an atmosphere saturated with the solvent used to make the consolidant solutions. The pigments were applied from an aqueous slurry with no added binder, which resulted in a very powdery surface.

The blocks were treated in 1989 with 5% solutions of poly(vinyl acetate) AYAF<sup>4</sup> in acetone, ethanol, toluene, and xylene, and a similar concentration of Acryloid B72 in the same solvents, along with a solution in diethylbenzene. The center area of the blocks were left untreated so that a visual comparison of an untreated and a treated area could be evaluated, along with the formation of tidemarks. Color images (Hansen, Lowinger, and Sadoff 1993:9) illustrated that the darkening that occurred in an open

atmosphere (when acetone, toluene, and xylene were used as solvents) was not apparent when the consolidant solutions were applied in a saturated atmosphere.

In late 1994, working on the assumption that these two polymers should be soluble in the future, the blocks were re-treated by spot treatments with solvent alone. Acetone could not be delivered to the previously consolidated painted surface by brush techniques without removing pigment; however, acetone could be delivered from an eyedropper without disturbing the surface. The discolored areas of four blocks, two previously treated with Acryloid B72 in toluene and two previously treated with poly(vinyl acetate) in acetone, were treated by spot application of acetone in a vapor-saturated atmosphere. (When treated with one to three applications of acetone in an open atmosphere, the discoloration was undiminished.)

One block of each consolidant type was placed in a glove bag containing open pools of acetone for thirty minutes, then treated while still in this environment. Discoloration of red and yellow areas disappeared, but was still quite noticeable in white areas. However, two other blocks that had remained in this environment for two hours were treated with three applications of acetone; after removing these blocks from the glove bag (allowing residual solvent to evaporate), it was not possible to visually discern where the consolidant had been applied. It was, however, possible to distinguish the areas that had been previously consolidated from the central unconsolidated area because pigment could be removed from the center by touching it lightly with the finger. Previously consolidated areas re-treated with acetone still retained their resistance to pigment removal.

This example illustrates the possibility for re-treatment of a previously consolidated object, either to eliminate darkening or to remove tidemarks that are assumed to be the result of uneven consolidant distribution, if the original consolidant is not expected to become insoluble. Such a method is less complicated than attempted removal of a consolidant, and in this instance no preconsolidation was required. However, it has been noted (Hansen and Volent 1994) that when solvent evaporation is retarded, and the solvent allowed to remain in contact for longer periods of time, greater potential exists for solvent interactions with sensitive materials present in the paint layer, ground, or substrate. Solvent interaction tests done in an open atmosphere may not be adequate to readily determine suitable solvent systems for use in a saturated atmosphere; solvent interaction tests must be done under the conditions in which they will be used.

---

## Conclusion

The re-treatment of matte painted wood objects requires both a knowledge of the materials and methods that were used in the past, and an understanding of the reasons why the original treatment may have been unsuccessful. For many objects treated before—or without—the systematic documentation of procedures and materials, ascertaining specific re-treatment options may be difficult even if requisite analytical support is available. Another requirement is a knowledge of how the materials (including solvents) were used and how compatible the properties of the consolidated paint layer are with the wood substrate, an area that has not been extensively studied.

Where specific documentation does not exist, a general knowledge of available materials and techniques during specific time periods



and in specific geographic areas may be of help. A definitive summary or review does not now exist, but an initial compilation could begin with teaching texts and "handbooks" for conservation treatments, articles describing case studies, treatment reports on file in museums or other institutions, and also with oral histories. In addition to identification of the materials that have been used, designing re-treatment strategies requires a knowledge of the expected aging characteristics of individual materials, particularly in regard to solubility.

For those materials that remain soluble, and when the discoloration or lack of consolidation is a result of uneven consolidant distribution (and not of "staining" or other solvent interactions, including physical disruption of the surface due to the consolidation procedure), several possibilities for re-treatment exist. One possibility is removal of a previous consolidant, which may require another consolidation procedure prior to removal. Another possibility is to remove excess consolidant while leaving enough residual consolidant to maintain cohesion and adhesion. It may also be possible to redistribute the consolidant in a manner that reduces the final concentration but does not contribute to glossiness or darkening.

In regard to the first possibility, newly developed techniques for cleaning varnishes may have great potential for the treatment of painted wood objects. Regarding the redistribution of previous consolidants, the use of a saturated vapor atmosphere to inhibit solvent volatility has been discussed (and may be particularly important for the removal of tide-marks). However, other methods that work on a similar principle (such as using a low-volatility solvent) also have potential.

It has been suggested in the conservation literature that future solubility is not a requirement when the original paint surface is highly fragile, because it is not likely that a resin can be removed from such a surface. It has also been suggested that thermosetting resins may have possible applications because they might be used in very small quantities. Since it is now apparent that re-treatment of fragile surfaces may be possible, these approaches should be reconsidered.

---

## Acknowledgments

The authors would like to thank Andrea Rothe for allowing them to discuss his treatment of the *Adoration of the Magi*; John Griswold for re-treating the object facsimiles in a saturated vapor atmosphere; and Michele Derrick for comments and suggestions in preparing this manuscript.

---

## Notes

- 1 Alternative explanations for darkening encountered in the conservation literature have been based on either the differences in the refractive indexes of pigment particles and consolidants, or *reverse migration* of a consolidant solution to the surface as a result of solvent evaporation. The reasons these phenomena have been considered by the authors to have minimal relevance in the consolidation of porous paint have been extensively discussed by Hansen, Lowinger, and Sadoff (1993) and Hansen, Walston, and Bishop (1993:xlvi–xlix).
- 2 See Appelbaum (1987:67) for a more general discussion of internal consolidation and re-treatability in relation to the concept of irreversible treatments.
- 3 See Stavroudis (1990) for more detailed comments on the use and formulation of gelled solvents.
- 4 PVA AYAF is a molecular weight grade of poly(vinyl acetate).

---

## Materials and Suppliers

**Acryloid B72**, Rohm and Haas Co., Independence Mall Street, Philadelphia, PA 19105.

**PVA AYAF**, Conservation Materials, Ltd., 100 Standing Rock Circle, Reno, NV 89511.

**Shell Odorless Mineral Spirits**, A. G. Layne, 4578 Brazil St., Los Angeles, CA 90039.

**Triton X-100**, Sigma Chemical Company, P.O. Box 14508, St. Louis, MO 63178.

---

## References

- Appelbaum, Barbara
- 1987 Criteria for treatment: Reversibility. *Journal of the American Institute for Conservation* 26(2):65–74.
- Daniels, V., ed.
- 1988 *Early Advances in Conservation*. London: British Museums Publications.
- Erhardt, D., and J. J. Bischoff
- 1993 Resin soaps and solvents in the cleaning of paintings: Similarities and differences. In *ICOM Committee for Conservation, 10th Triennial Meeting, Washington, D.C., USA, 22–27 August 1993, Preprints*, vol. 1, ed. J. Bridgland, 141–46. Paris: ICOM Committee for Conservation.
- Hansen, E. F., and N. Agnew
- 1990 Consolidation with moisture-curable isocyanates: Polyureas and polyurethanes. In *ICOM Committee for Conservation, 9th Triennial Meeting, Dresden, German Democratic Republic, 26–31 August 1990, Preprints*, vol. 2, ed. K. Grimstad, 557–62. Los Angeles: ICOM Committee for Conservation.
- Hansen, E. F., M. H. Bishop, P. Volent, and R. Lowinger
- 1993 The conservation of matte paint surfaces in ethnographic and contemporary art. In *Postprints of the Paintings Specialty Group Session, 21st Annual Meeting of the AIC, Denver, 1993*, 67–71. Washington, D.C.: American Institute for Conservation of Historic and Artistic Works (AIC).
- Hansen, E. F., R. Lowinger, and E. Sadoff
- 1993 Consolidation in a vapor-saturated atmosphere: A technique for minimizing changes in the appearance of matte, powdering surfaces. *Journal of the American Institute for Conservation* 32(1):1–14.
- Hansen, E. F., E. Sadoff, and R. Lowinger
- 1990 A review of problems encountered in the consolidation of painted ethnographic objects and potential remedies. In *ICOM Committee for Conservation, 9th Triennial Meeting, Dresden, German Democratic Republic, 26–31 August 1990, Preprints*, vol. 1, ed. K. Grimstad, 163–68. Los Angeles: ICOM Committee for Conservation.
- Hansen, E. F., and P. Volent
- 1994 Technical note on solvent sensitivity testing of objects for treatment in a vapor-saturated atmosphere. *Journal of the American Institute for Conservation* 33(3):315–16.
- Hansen, E. F., S. Walston, and M. H. Bishop, eds.
- 1993 *Matte Paint: Its history and technology, analysis, properties, and conservation treatment with special emphasis on ethnographic objects*. Marina del Rey, Calif.: Getty Conservation Institute.
- Hatchfield, P. B., and R. F. Koestler
- 1987 Scanning electron microscopic examination of archaeological wood microstructure altered by consolidation treatments. *Scanning Microscopy* 1(3):1059–69.
- Horie, C. V.
- 1990 *Materials for Conservation*. London: Butterworths.

- Horton-James, D., S. Walston, and S. Zounis  
1991 Evaluation of the stability, appearance, and performance of resins for the adhesion of flaking paint on ethnographic objects. *Studies in Conservation* 36(4):203–21.
- Johnston, R. M.  
1967 Geometric metamerism. *Color Engineering* (May/June).
- Keck, C. K.  
1977 *Lining Adhesives: Their History, Uses and Abuses*. Washington, D.C.: AIC.
- Keck, S.  
1984 Some picture cleaning controversies: Past and present. *Journal of the American Institute for Conservation* 23:73–87.
- Lucas, A.  
1924 *Antiques: Their Restoration and Preservation*. London: Edward Arnold and Co.
- Marijinessen, R.  
1967 *Dégradation, conservation et restauration de l'oeuvre d'art*. Bruxelles: Editions Arcade.
- Piqué, F.  
1994 Conversation with the author. The Getty Conservation Institute, Marina del Rey, Calif.
- Rosen, D.  
1950 The preservation of wood sculpture: The wax immersion method. *Journal of the Walters Art Gallery* 13–14:45–71.
- Rothe, A.  
1992 Mantegna's painting in distemper. In *Andrea Mantegna*, ed. J. Martineau, 80–93. London: Olivetti.  
1994 Conversation with the author. The J. Paul Getty Museum, Malibu, Calif.
- Schniewind, A. P., and P. Y. Eastman  
1994 Consolidant distribution in deteriorated wood treated with soluble resins. *Journal of the American Institute for Conservation* 33(3):247–55.
- Southall, A.  
1989 Wolber's corner. *Conservation News* 39:11–12.
- Stavroudis, Chris  
1990 Carbopol 934, Ethomeen C25, Ethomeen C12, Armeen. *Newsletter (Western Association for Art Conservation)* 12(2):13–14.

# The Ultrasonic Mister

## Applications in the Consolidation of Powdery Paint on Wooden Artifacts

*Stefan Michalski, Carole Dignard, Lori van Handel, and David Arnold*

**P**OWDERY MATTE PAINT is a paint layer with little or no binder between the pigment particles; it can therefore transfer easily when there is contact with another surface, or it can detach if it is submitted to vibration. In the consolidation treatment of powdery paints, the aim is to improve both the cohesion of the pigment particles and their adhesion to the substrate, while minimizing the effect of the consolidation on the appearance of the paint layer (Michalski and Dignard 1997).

Often, improvements in handling, storage, packing, and transportation procedures offer a viable alternative to consolidation treatment (Guillemard and Renard 1992). However, there can be instances when the choice is either consolidation or acceptance of paint loss—for example, when a powdery object cannot be physically secured to prevent losses from normal building vibration, air movements, or vertical orientation. Static charge also can cause losses. In those rare instances where there is lack of control over access, handling, or dust protection, consolidation may be the safest preservation option. If consolidation is required, ultrasonic misting, with its advantages and limitations, should be considered as an option. This chapter will present a discussion of the method, tests performed on powdery painted wood samples, and use of the treatment method for two wooden objects of very different provenance and history. Construction of the ultrasonic mister will be described, in the hope that other conservators will experiment further with this new technique.

---

### The Ultrasonic Mister: General Description

To atomize a consolidant solution into a mist, a dilute solution (for example, 0.5% Acryloid B72 in ethanol; 0.5% gelatin in water; or 0.25% methyl cellulose, 400 centipoises, in water) is placed in a bottle positioned over the ultrasound oscillator of an ultrasonic humidifier (Fig. 1). An air pump connected to the bottle forces the mist out through tubing to a nozzle and onto the object. Some of the mist will penetrate into the porous layer, but some will bounce off and could potentially deposit on adjacent areas of the object. To avoid this, the treatment is performed in a fume hood; alternatively, a local extraction system using a vacuum cleaner and voltage regulator can be used to suck up excess mist. Figure 1 shows the ultrasonic mister, as originally developed by Michalski,<sup>1</sup> and Figures 2 and 3 show details of the handpiece and various nozzles. Complete details on the equipment, setup, and method are given in the appendix to this article.

Figure 1

The ultrasonic mister: (1) ultrasonic humidifier; (2) water in the reservoir; (3) low-density polyethylene squeeze bottle, "Boston" type; (4) dilute consolidant in bottle; (5) wooden retainer to stabilize bottle; (6) air pump; (7) valve to control quantity and velocity of mist; (8) tube carrying air from pump into bottle; (9) tube carrying mist from bottle to nozzle; (10) handpiece; (11) copper pipe slot nozzle, out of which mist is projected; (12) tube carrying extracted excess mist; (13) vacuum cleaner extracting excess mist; (14) speed control for extraction force.

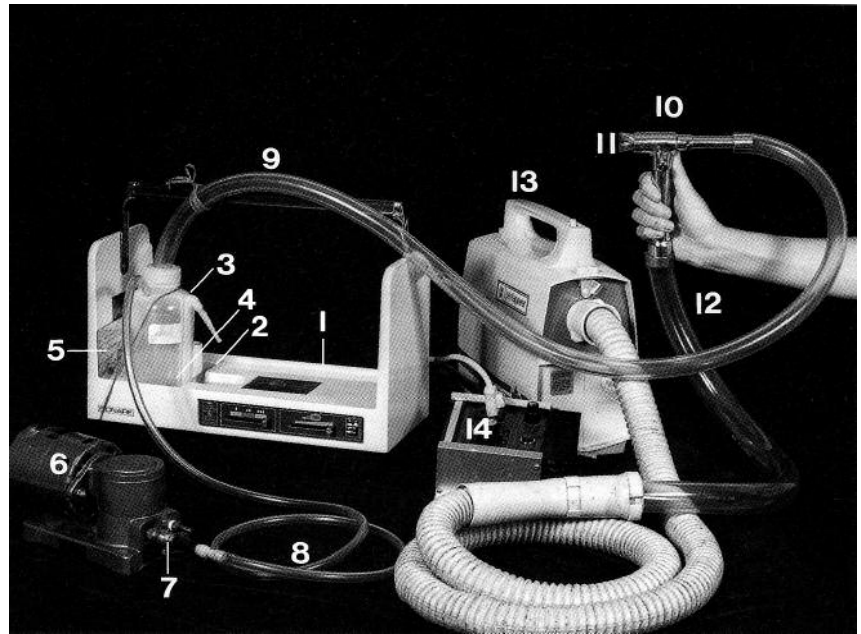

When misting a powdery paint, the consolidant solution must penetrate the full thickness of the pigment layer down to the substrate; otherwise, incomplete consolidation will result. If too much solution is applied, it could dry on the surface and cause skinning or glossiness and may also hinder further applications. The mist flow can be reduced or increased by using the air-pump valve. The flow remains as narrow as the aperture of the nozzle, so it can be directed with precision. The nozzle

Figure 2

The ultrasonic mister handpiece (Fig. 1, no. 10), consisting of a copper pipe slot nozzle, a copper reducing tee, and a handle. Insets: a coin is inserted in the copper pipe and pinched in a vise to create a slot nozzle.

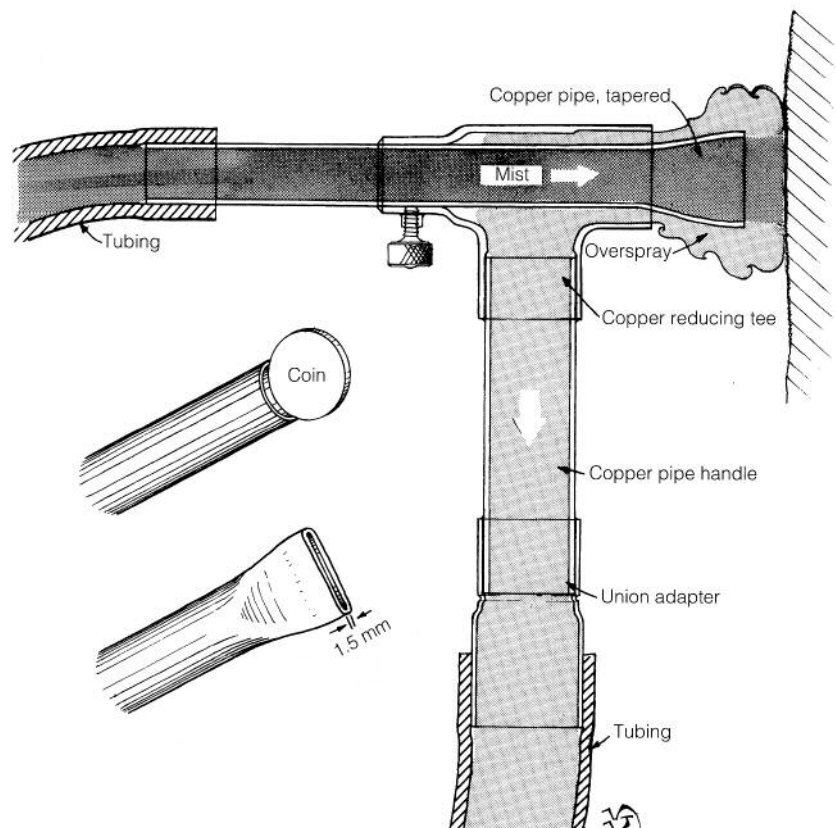
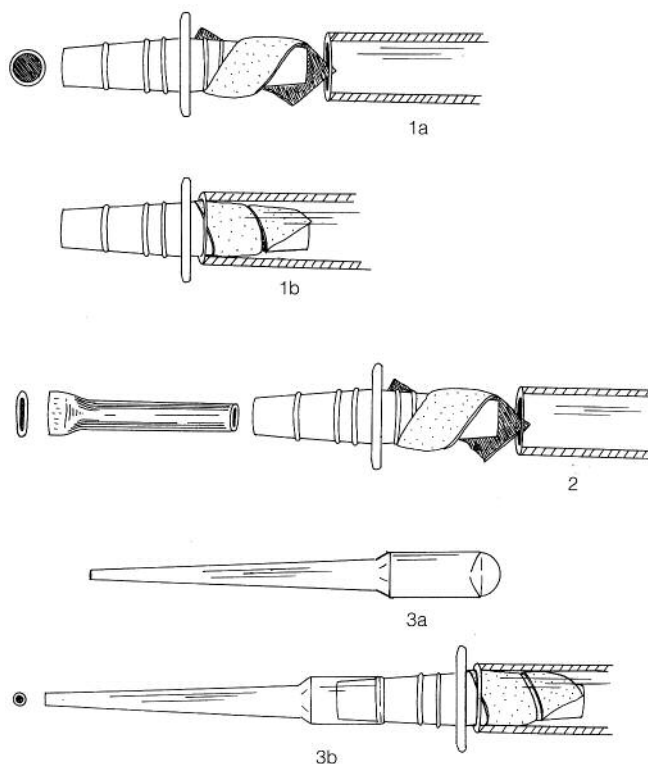

Figure 3

Various nozzle configurations: (1) quick-disconnect fitting (dimensions 6.4–7.9 mm) with (a) blotter paper wrapped around it, and (b) inserted into tubing; (2) Nalgene quick-disconnect configuration with addition of miniature copper tube (6.4 mm outside diameter); (3) disposable, plastic pipette, (a) before incorporation and (b) after it has had the end cut off and been added to Nalgene quick-disconnect configuration.



must be held within a few millimeters of the object and kept stationary for as long as the mist is seen to wick into the paint layer (it will wick until it fills all the pores, to the bottom of the layer). During preliminary testing, penetration to the bottom of the paint layer was verified by misting various consolidant solutions onto pigments applied to a transparent glass substrate (Michalski and Dignard 1997). When the surface being misted is thoroughly wetted, a shiny appearance indicates that the porous layer is saturated with solution. The nozzle should then be moved to the next area. When the solvent evaporates, it will leave only a small quantity of solid consolidant distributed within the pores. Consolidation using this device may require several applications of the dilute solution.

---

## General Problems Encountered in Consolidation

Conservators have often encountered poor results with consolidation methods for powdery pigments—for example: (1) darkening, glossiness, or skinning due to poor penetration; (2) darkening due to color saturation; and (3) smearing. These problems are often linked to the fact that too much consolidant is being used, at concentrations that are too high. In this respect, the application technique is important. Ultrasonic misting has some advantages over other techniques such as pneumatic spraying and drop applications. (The use of vapor-saturated environments is an option independent of application technique [Hansen, Lowinger, and Sadoff 1993].) Also, the choice of both the resin and the solvent are important factors, as they can affect viscosity, wetting, evaporation rate, strength of bonding, and degree of color change (Michalski and Dignard 1997).

### Lack of penetration

Lack of penetration is the most common problem in attempts at consolidation. The effects are darkening, transparency, glossiness, or skinning.

Problems with penetration can occur if the consolidant is too viscous to penetrate the small capillaries between the pigment particles, if the solvent evaporates faster than the solution's wicking time, if wetting is poor, or simply if too much consolidant is applied and it pools on the surface. The last point is a serious drawback to both drop application and pneumatic spraying, as the amount of consolidant delivered cannot be finely controlled. The minimum used in these techniques is one macroscopic drop, which for some paint layers can be too much at once. Depending on the consolidant penetration rate in the paint layer and on the evaporation rate of the solvent, a drop may take too long to penetrate and may end up drying on the paint surface. (Consolidation within vapor-saturated environments is a means of eliminating evaporation so that even complete wicking can take place in due course.)

Ultrasonic misting is a different approach, whereby dilute solutions of low viscosity are gradually applied locally and in small, controllable quantities; pooling can thus be avoided. Furthermore, because the mist is applied very close to the object, little evaporation takes place during application; the droplets are delivered in an airstream saturated with solvent, at a concentration very close to the concentration of the original solution. In contrast, pneumatic spray drops undergo rapid evaporation in the ambient air before reaching the object, to the point of becoming too viscous to penetrate.

### Darkening

Darkening due to color saturation occurs when the addition of a consolidant within a porous layer reduces the void volume, and thus also reduces the air-solid interfaces that scatter light. Colored pigments become more saturated. If the pigment has a refractive index well over that of the consolidant (for most consolidants, it is about 1.5), then at least the pigment remains fairly opaque. Pigments with an index of refraction near that of the consolidant will not only saturate in color, but they will gain transparency.<sup>2</sup> If very little original binder is present, however (as should be the case if the surface is powdery), a significant color change can be avoided if a consolidant is applied sparingly and it is evenly distributed.

In contrast to pneumatic spraying and drop application, ultrasonic misting allows application of a flow of very small droplets of consolidant in controllable quantities. By treating the object with successive applications of a mist of dilute consolidant, the treatment can be assessed gradually, and consolidation can be stopped before the surface color becomes noticeably different.

### Smearing

Smearing can occur with both pneumatic spraying and drop application because of the size and velocity of the drops hitting a delicate, powdery surface. Excess solution on the surface can also run, which can displace particles. Ultrasonic mist droplets are two to one hundred times smaller than pneumatic spray droplets.<sup>3</sup> Mist droplets typically range from 1 to 5  $\mu\text{m}$  in diameter, comparable to average pigment particle sizes, which range from 0.1 to 10  $\mu\text{m}$ . The mist velocity can be fine-tuned by a valve on the air pump, down to a minimum flow.

Precision of application is also greater with ultrasonic misting. The stream of mist comes straight out of the fine nozzle, with little flare,

allowing precise control as to where the consolidant is applied; with pneumatic spraying or drop application, the minimum surface area that can be consolidated is much larger.

---

## Limitations of the Ultrasonic Mister

While the ultrasonic mister can reduce or control the three problems noted, the following can be limitations or shortcomings to its use:

1. The machine must be assembled and fine-tuned before being operative.
2. Drops may accumulate in the tubing and nozzle and could fall on the object if the nozzle is directed downward. Blotter liners can control most of this problem (Fig. 3).
3. Since the solutions are misted in narrow bands, there can be an overlap in application of consolidant if the first band is dry when the adjacent one is applied, thus doubling the consolidant; there is concern that this may cause a pattern of lines on the object. As much as possible, adjacent bands should be butted when wet to avoid this problem.
4. The process of consolidation is relatively slow. This is a consequence of the slow delivery of solution and of the incremental application of dilute solutions.
5. Ultrasonic misting is generally not effective as a treatment for flaking, cleaving, or cupping paint because the concentration of the consolidant is inadequate to bridge the gap between flake and substrate. Also, the flake may cup on drying. Even with a very slow mist velocity, it is difficult to avoid dislodging flakes; however, tiny flakes can be consolidated by misting, as in the case of flaking gouaches (Weidner 1993; Dignard et al. 1997). Paint that is both flaky and powdery can be delicately misted to increase cohesion and to relax the shape of flakes before they are repositioned and fixed to the substrate by other means.

The limitations are discussed further in the following case studies.

---

## Tests Performed on Painted Wood Samples

The following observations were gathered from ultrasonic misting tests, using aqueous solutions of gelatin, methyl cellulose, or solutions of Acryloid B72 in ethanol. The tests were performed on various dry pigments that had been applied as a slurry with no binder onto wood planks.

1. Individual pigments have different bonding requirements. For example, the pigment particles of green earth, red ochre, and raw umber formed cohesive layers even though no binder was present; therefore, in practice, such pigments may not need consolidation. Others such as calcium carbonate, chrome yellow, ivory black, and ultramarine were found to be much more powdery. Similarly, the improvement in bonding for a given consolidant can vary from pigment to pigment. Each pigment requires a treatment tailored to its physical cohesive strength and its propensity to change color when the consolidant is applied.



2. Solvents alone can change the color of some pigments. Distilled water applied on green earth and red ochre darkened their surfaces, while ethanol on ultramarine caused lightening of the surface (Michalski and Dignard 1997).
3. Natural resins in unaged wood can migrate and stain when the painted wood is wetted during treatment. Consolidation tests using 0.5% Acryloid B72 in denatured ethanol, applied on new pine planks painted with various pigments, caused the wood resins to migrate and stain the pigment surfaces in dark streaks. This problem is expected with solvent-based consolidants and on all softwoods, especially if new. For water-based consolidants, resin migration was rarer, but it did occur in one instance.
4. End grain will wick up the consolidant more quickly than will radial or tangential surfaces, which makes it difficult to know when enough consolidant has been applied. It may be necessary to establish the speed of application on radial or tangential sections, and then to retain this speed on end-grain surfaces.
5. The problem of dust on a powdery paint is a concern. Dust was simulated by sprinkling the painted wood samples with fine dust from a vacuum cleaner, and exposing them to thirty minutes of cigarette smoke in a chamber. Misting did not reveal any dirt migration, such as tidemarks; however, in practice, the authors still view dirt and dust as potential problems to the consolidation process and to the final visual appearance of the paint. Preliminary tests on the object are essential.
6. Mist is applied to an object in adjacent bands; where the bands overlap, the quantity of consolidant will be double; therefore, the color change could be more significant. To avoid this, each band is butted closely while avoiding overlap and, most important, the band is applied before all the solvent in the previous band evaporates. The wet consolidant can then wick into and blend with adjacent areas. Also, successive coats of consolidant are applied in bands at right angles to those of the previous coat. In practice, overlap was found to be a problem mostly after four applications of ethanol-based solutions (0.5% Acryloid B72), which evaporate faster than aqueous solutions.
7. Brushstrokes, which form a pattern of long, raised ridges on some painted surfaces, often need additional consolidation because of their greater thickness. They can be selectively treated, using a narrow slot nozzle designed to focus the mist stream along their length. Striping or other superimposed decoration may also require further misting, with care taken to prevent the mist stream from flooding adjacent areas of the base coat.

---

## Case Studies

### Egyptian painted coffin panel

This polychromed panel is one of six that are a part of a Middle Kingdom, Twelfth Dynasty coffin excavated around 1915 at the Deir el-Bersheh site on the east bank of the Nile about 175 miles south of Cairo, and now in the collection of the Museum of Fine Arts, Boston (Fig. 4). The panel

*Figure 4*

Consolidation of Egyptian painted coffin panel (Middle Kingdom, Dynasty 12) using the ultrasonic mister. Notice the Nalgene quick-disconnect nozzle and the blotter between the nozzle and the tubing. Museum of Fine Arts, Boston (acc. no. 1915-5-532).

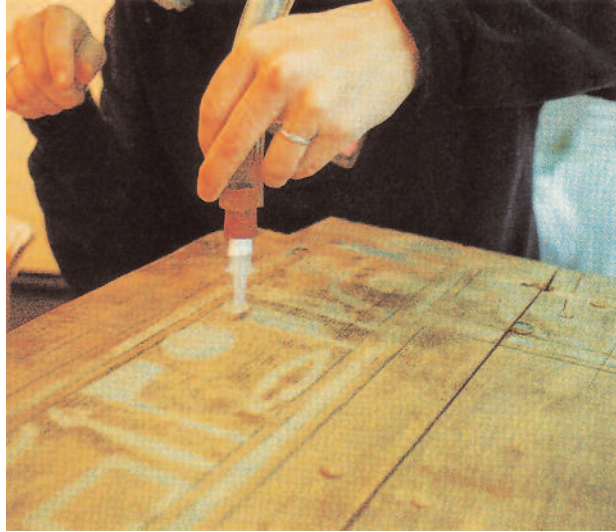

serves as an end piece and was detached from the rest of the coffin during excavation and subsequent shipping. Coarse calcium carbonate gesso fills knot holes and joints, and the panel is covered with an ochre-tinted calcium carbonate ground. The painted surface is a faint band of polychromy that follows the contour of three sides of the coffin end: Egyptian blue hieroglyphs are outlined in white, and there are traces of orpiment in negative spaces of the design. Black and white border and outline the design.

#### Condition

The Lebanese cedar substrate consists of four thick boards that are fitted together with wooden pegs, tenons, and bands of copper. One plank is split, and the piece is detached from the rest. There are many areas of abrasion and loss to the calcium carbonate ground. The panel was stored, transported, and treated in a horizontal orientation to avoid any further loss of pigment. Prior to treatment, most areas of the painted design were poorly bound and extremely powdery. In several areas, pigment particles had previously been displaced, but the design was generally intact and legible. The Egyptian blue pigment was the most powdery and was easily transferred with surface contact. The orpiment, which is of large particle size, and the ochre ground were equally fragile. The white was relatively well bound; however, microscopic examination revealed a minute craquelure pattern. The black appeared to be fairly well bound to itself but was detached completely from the substrate. Dirt, dust, and fiber particles covered most of the surface.

#### Treatment considerations and objectives

The coffin will eventually be reassembled for exhibition; the end-piece panel will be displayed in its original vertical position. Due to the fragility of the decorative layer, consolidation was the primary treatment procedure. Prior to consolidation, surface dirt and fibers were removed with tweezers and the touch of a small, soft, damp sable brush.

Technical analyses to identify binding media used in the polychromy were performed on samples by the staff of the Department of Objects Conservation and Scientific Research at the Museum of Fine Arts, Boston. It was possible to distinguish minute quantities of an animal

binder using high-performance liquid chromatography (HPLC), following a technique described by Halpine (1992).

Since staining of the ground and/or wood substrate is a frequent side effect when using aqueous consolidants (Hatchfield 1988), and since earlier tests indicated that staining by migration of wood resins through the pigment layer was also a threat when using solvent-borne consolidants, solvent tests were performed on non-accessioned, painted cedar fragments of similar coffins provided by the museum's Department of Ancient Egyptian, Nubian, and Near Eastern Art. Water, denatured ethanol, toluene, and acetone were applied by dropper to the surface of both bare and painted wood and allowed to evaporate. These tests indicated that, in this case, water stains were the biggest problem. A solution of 0.5% Acryloid B72 in 97% ethanol and 3% toluene was tested and chosen as the least interfering consolidant.

### Consolidation

The panel was the first object treated by the authors—van Handel and Dignard—using the ultrasonic mister, and several modifications to the mister's original setup and method were found most practical. For instance, although the copper nozzle was used to consolidate broad areas of design, the Nalgene quick-disconnect nozzle (Figs. 3 and 4) was most often used because it allowed smaller local applications and could be finely directed with the fingertips. To prevent drops from forming inside the nozzle, blotter paper was inserted into the space between the quick-disconnect fitting and the tubing (Fig. 3). The blotter paper strip was changed at regular intervals; several nozzles prelined with blotter paper were used in succession to speed up the treatment. The overspray extraction unit, consisting of the reducing tee tubing, and vacuum cleaner, shown in Figure 1 (see also the appendix to this article), was not used because treatment took place in a fume hood. The consolidant was applied following the design of the object, or following the wood grain when it could be seen through the paint. In total, four coats of Acryloid B72 were applied; no color change could be perceived, and there was no evidence of lines caused by overlapping bands. Bonding was improved but it was still weak, especially in the thicker layers of the coarse Egyptian blue pigment; however, pigment particles could no longer be displaced through surface contact.

### Pennsylvania-German low post bed

This painted single bed is unique because of its decorative footboard, seen in Figure 5. While similar motifs are commonly associated with early Pennsylvania chests, it is exceedingly rare to find a bed with such a decorative treatment. The painted Fraktur script includes the name of the bed's owner, Katarina Barbara Luckenbillin, and the date, 1789. Colors in the scribed design areas were applied directly to the bare wood, and the surrounding blue was carefully painted around them. The pigments include Prussian blue, lead white, and cinnabar. The rest of the bed parts were painted with a mixture of lead white and Prussian blue.

### Condition

The bed parts are composed of both white pine (*Pinus strobus*) and tulip poplar (*Liriodendron tulipifera*), and include headboard and footboard assemblies and two side rails. For many years, the headboard and

*Figure 5*  
Footboard of Pennsylvania-German low post bed, 1789, with painted design. Philadelphia Museum of Art (acc. no. 1992-10-1).



footboard had been stored on end, each with a post in direct contact with an earthen floor. Both posts became rotted and suffered some deformation and/or loss of material as a result. Prior to treatment, the paint was generally very unstable. Most areas were powdery and some areas had lost all of the paint. Thickly applied paint in the designs was especially friable. The pine boards have suffered paint losses directly over latewood portions of the wood growth rings.

Treatment began with the consolidation of the powdery paint. Once the surface was stabilized, the disfigured turnings of the posts and other losses could be restored, and areas of major paint loss could be color-compensated. The bed is now reassembled and stands in the permanent Pennsylvania-German exhibition at the Philadelphia Museum of Art.

#### Technical analysis

Technical analyses to identify binding media and to confirm pigment identification were performed in the Philadelphia Museum's analytical laboratory. All paint samples prepared for binder analysis with Fourier-transform infrared (FT-IR) spectroscopy were too lean to be conclusive, but the infrared spectra indicated the possible presence of a proteinaceous binder (animal glue, or possibly casein).

Besides ultrasonic misting, two other treatment options were considered. Pneumatic spray application with Acryloid B72 in diethylbenzene (Welsh 1980) was rejected as much for its lingering noxious smell as for a concern that the high-velocity output of a spray gun might dislodge paint particles. Also, a vapor-saturated atmosphere (Hansen, Lowinger, and Sadoff 1993) was rejected because consolidation within a bag was judged to be too difficult to perform and assess practically; there was also lack of laboratory space.

#### Consolidation

An aqueous consolidant was chosen for the pine headboard and footboard to avoid resin staining. Tests performed on samples of painted tulip poplar plaques indicated that the solution would perform equally well over the tulip poplar substrates. Some good results have been reported on producing a mist from a 0.5% solution of Dow Methocel A4C methyl cellulose in water (Dignard et al. 1997); however, consistent results could not be obtained with the Philadelphia Museum apparatus at this concentration, which is almost too viscous to mist. A 0.25% solution was generally

used, although some success was experienced using concentrations as high as 0.375%.

Several modifications to the original Canadian Conservation Institute–designed apparatus were made. A pinhole was made in the shoulder of the consolidant bottle so the fluid level could be easily maintained with periodic additions by syringe of dilute consolidant. The air-input tube was modified, as shown in Figure 6 and described in the appendix under the heading “Modifying the plastic bottle.” This modification is intended to direct the incoming air around the inner walls of the bottle and thus minimize disturbance of the rising consolidant mist. For convenience, a burette stand and a pair of adjustable clamps were used to independently hold both the output tube and the neck of the consolidant bottle in place. An overspray collector was fabricated, but it was not used because a good-quality voltage regulator was not available. The inexpensive one used for the treatment caused the vacuum cleaner to surge, resulting in an inconsistent, and thus unsatisfactory, performance. Despite this omission, no color change or banding could be perceived when consolidation was completed. Because of the low concentration used, eight coats of methyl cellulose (0.25%) were applied, approximately equivalent to the quantity of consolidant in one application of 2.0%. No color change or signs of overlapping can be perceived by eye.

---

## Conclusion

The cohesion of pigment particles has been significantly improved with the ultrasonic misting technique, even in the design areas where pigments were applied thickly.

*Figure 6*

The air-input assemblage inserted into the shoulder hole in the LDPE bottle. The quick-disconnect fitting is hotmelted to the bottle. Inset: as viewed from above, showing air movement created by opposing 3–5 mm holes in tube.

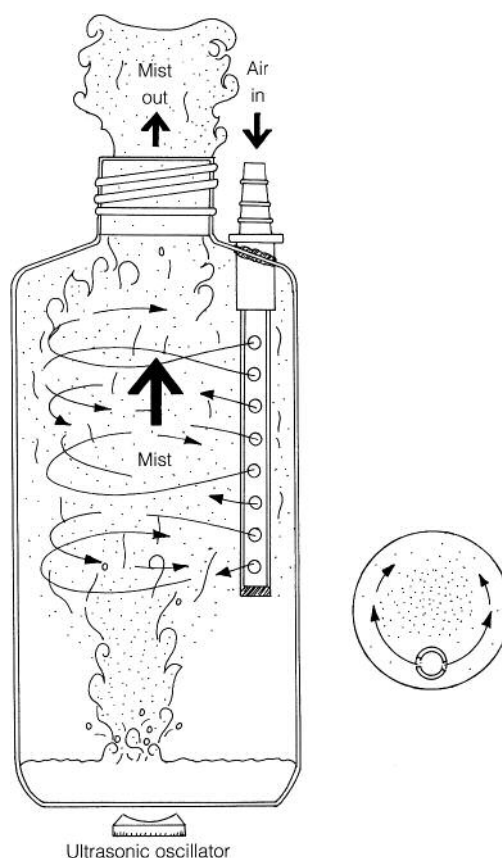

Consolidation through pneumatic spraying, vapor-atmosphere, or drop applications was not possible in the case studies of two wooden objects with powdery painted surfaces; but ultrasonic misting was successful. The equipment is relatively easy to assemble and use, and the method offers several advantages over other application methods: small droplet size; low mist velocity; a narrow, easily directed nozzle and stream of mist; and control of the quantity and concentration of consolidant applied. Incremental applications of a dilute, nonviscous solution of consolidant mist allow one to find a compromise between minimum color change and maximum bonding.

---

## Acknowledgments

The authors acknowledge the assistance of many colleagues: Bob Barclay, who helped to make the original mister handpiece; Janet Mason, Carl Schlichting, Anita Henry, Charles Hett, Martha Segal, Lisa Mibach, David Lee, Denis Guillemard, Julie Dennin, and Nancy Odegaard, who communicated their comments on ultrasonic misting. Thanks also to Peter Newlands, Gregory Young, Bob Barclay, Robyn Douglas, Sherry Guild, and Wanda McWilliams at the Canadian Conservation Institute; Caroline Marchand at the Canadian Museum of Civilization; and Susanne Gänsicke at the Boston Museum of Fine Arts, who experimented, or assisted with, the mister for various treatments. Appreciation is extended to Carl Schlichting, who drew some of the illustrations; Beth Price and Richard Newman for analytical services; and Arthur Beale, David DeMuzio, Tom Stone, and the Andrew W. Mellon Foundation, who facilitated this cooperative effort.

---

## Appendix: Ultrasonic Mister Equipment, Setup, and Method

The following is a detailed procedure for adapting a household humidifier for use as an ultrasonic mister (Fig. 1). Except for the voltage regulator, all the equipment is available from hardware stores, aquarium supply shops, and plastics distributors (see Materials and Suppliers). If a conservation lab owns a voltage regulator, a vacuum cleaner, and an air pump (or has a compressed air source), the approximate cost is Can\$125 (US\$100). Only the handpiece may need to be custom-built, using simple materials and tools.

It is important to note recent research, undertaken subsequent to the development of the modified ultrasonic humidifier, which explored two devices used in respiratory therapy that adapt more readily for use as consolidant delivery systems (Arnold 1996:102). When tested over the entire range of mist-producing consolidant concentrations, a pneumatic nebulizer and an ultrasonic nebulizer both produced mist particles with mean diameters of 0.7 to 1.1  $\mu\text{m}$ . Both devices also generated mists using solutions at significantly higher concentrations than the converted humidifiers, and the ultrasonic nebulizer demonstrated superior control and precision. Although the pneumatic nebulizer is the least expensive means for producing consolidant mists (if a compressed air source is available), an ultrasonic humidifier, modified according to the following directions, remains a less expensive alternative to an ultrasonic nebulizer.

### Equipment and setup

#### Modifying the plastic bottle

Numbers shown in parentheses in the following paragraphs refer to Figure 1. A plastic squeeze bottle (3) for containing the consolidant

solution must be modified for use within the reservoir of the ultrasonic humidifier. Large, low-density polyethylene (LDPE) “Boston” design squeeze bottles allow the ultrasound to pass through and create a mist of consolidant inside the bottle (PVC and high-density polyethylene bottles do not work). Cut or melt a hole in the lid of the bottle, and one on the shoulder, to fit the lengths of tubing leading to the handpiece/nozzle and pump, respectively.

An optional step is to modify the air-input tube (8) and to secure it to the bottle in the following manner: cut a 10 cm length of 6 mm internal diameter (ID) tube, and seal it at one end with hot-melt glue; then, cut a series of 3–5 mm holes in opposing sides of the tube (about six holes, spaced evenly along the length of the tube). Insert the unsealed end of the tube into a Nalgene quick-disconnect fitting that has been hotmelted to the bottle. Figure 6 shows this modified air-input assemblage inserted into the shoulder hole in the LDPE bottle.

### Small air pump and tubing

An air pump (6) of at least 200 l hr<sup>-1</sup> output without resistance, is connected by a 6 mm ID tube (8) to the bottle. The pump blows air into the bottle and forces the mist out into the nozzle tubing. The air pump may be connected to a variable transformer to regulate the air flow, or simply to a valve (7) to control the quantity and velocity of mist coming out. A standard compressed air source can be used.

### Nozzle and tube

The mist travels along clear 16 mm ID tubing (9) to the nozzle. Tubing walls 4 mm thick should be used to avoid kinks or sharp bends. Because some of the consolidant will collect on the tubing walls and drain to the lowest point, try to keep the tubing lower than the nozzle to ensure that the solution does not inadvertently drain out of the nozzle onto the object.

A circular nozzle (Fig. 3) was found useful in practice because it is small and lightweight, and it can be finely handled to direct the mist where required. Nalgene quick-disconnect fittings (6.4–7.9 mm) were found to be most useful. Nozzles with low-angle tapers are best, as they reduce the formation of droplets. Use blotters, as shown in Figure 4 and as discussed in the treatment of the Egyptian panel, earlier.

A nozzle with a slot aperture (11) can be useful for applying an even, uniform quantity of consolidant when it is moved across a surface. A slot aperture 20 mm long by 1.5 mm wide was found to be most practical. To make this, follow these steps:

1. Taper or flatten one end of a 15 cm length of copper pipe with a 13 mm ID (Fig. 2), by holding a large coin partway into one end of the copper pipe while squeezing the pipe in a vise until the pipe walls re-form against the coin faces. The taper angle should not be too abrupt or droplets of consolidant will form inside the nozzle.
2. Make the faces of the aperture parallel to each other.
3. File the inside lips of the aperture to make them smooth (burrs or irregularities will act as nucleation sites for droplets, which may fall on the object).

4. Droplets will still form; therefore avoid pointing the nozzle downward, and frequently wick up any droplets forming by slipping a blotter in the nozzle aperture during use.

Copper pipe was chosen to make the slot nozzle because it is readily available and easily worked. After two years of intermittent use, no corrosion products formed on the prototype, which was rinsed and blow-dried after use. If copper impurities are a concern, use polycarbonate (Lexan), which is inert and transparent, but more difficult to form. Since the nozzle is easily replaced, other nozzle shapes and sizes can be created to suit particular needs, as seen in Figure 3.

#### **Overspray extraction system**

Some of the mist that reaches the object is absorbed into the object, and some stays in the deflected airstream as overspray. There was concern that overspray settling on adjacent surfaces might cause glossiness or hinder future penetration of the consolidant. There was also concern regarding the serious health risk that consolidant mist can pose, even with aqueous solutions. An overspray extraction system using a copper reducing tee and handle (10), a vacuum cleaner (13), and speed control (14) is most effective. Unlike a fume hood, it is a mobile system, which works locally and allows the suction to be varied as needed. However, with flammable solvents, the fume hood must be used instead, since a flammable mist drawn through a vacuum cleaner motor can ignite and cause an explosion. With toxic, nonflammable solutions, the reducing tee extractor can be used in the fume hood.

**Reducing tee and handle.** Assemble the reducing tee and handle (10) as follows:

1. Slip a copper reducing tee over the nozzle, with the larger diameter encircling the nozzle aperture.
2. Connect the bottom part of the tee, through a pipe (the handle) and tubing, to the vacuum cleaner. To do this, screw or solder a 19 mm copper pipe to the tee to provide a handle, and a 19–25 mm reducing coupler to the bottom of the handle to fit the 25 mm ID vacuum cleaner tubing.
3. Screw the tee to the nozzle before use.

When assembled as shown in Figure 2, a 6 mm vacuum collar encircles the nozzle aperture, capturing overspray from the periphery of the nozzle. The force of the extraction is adjusted by changing the distance between the collar and the tip of the nozzle, or by the vacuum speed control.

**Vacuum cleaner, tubing, and speed control.** The vacuum cleaner (13) provides the force of extraction. Connective tubing (12) of the same diameter as the vacuum cleaner's normal hose, usually at least 25 mm, should be used. A wet/dry vacuum cleaner is recommended, if available. Normal vacuum cleaner suction must usually be reduced to less than 10%, using either a controlled leak in the vacuum cleaner hose or tubing, or a variable speed control (14)—either a solid-state speed control or a variable transformer of appropriate amperage.



## Method

### Filling the reservoir and installing the plastic bottle

Add enough tap water to the recessed reservoir (2) of the humidifier to maintain the manufacturer's recommended operating level once the bottle is in place. Center the bottle (3) over the ultrasound oscillator, making certain no air bubbles are trapped beneath it. Secure the bottle with a wooden retainer (5), a twist tie, or a metal clamp and support.

### Quantity and concentration of solution in the bottle

For water-based solutions, use the same height of consolidant in the bottle as in the water reservoir (i.e., 2–3 cm of solution in the bottle). Ethanol-based consolidants require between 0.5 and 1 cm of solution, with the bottle raised 1 cm from the oscillator, using a ring. Viscous solutions will not mist. Use very dilute solutions—for example, 0.5% aqueous or ethanol solutions.

### Adjusting the stream of mist

Keeping the humidifier controls at their maximum levels, adjust the mist velocity, using the valve on the pump (7), so that the mist moves fast enough to impinge on the surface, but not so fast as to disturb loose particles.

### Distance between object and nozzle

Hold the nozzle 5 mm or less from the surface and perpendicular to it. At this distance, the mist remains in a narrow jet, and no significant evaporation of solvent will occur before it hits the object.

### Quantity of solution applied during each application

As mentioned earlier, the consolidant solution must penetrate the full thickness of the pigment layer being consolidated, through to the substrate; otherwise, incomplete consolidation will occur. If too much solution is applied, it will dry on the surface and may cause skinning or gloss and hinder further applications. Control the application as follows:

1. Adjust the stream of mist to a slow, delicate flow.
2. Keep the nozzle stationary above the object and apply the solution as long as it is seen to wick into the paint layer. The solution will wick until it fills all the pores within the layer, to the bottom of the layer.
3. When the wet surface being misted begins to appear shiny, indicating that the porous layer is now saturated with solution, move the nozzle away to let the consolidated layer dry: the solvent will evaporate, leaving only a small quantity of solid consolidant distributed within the pores. *Do not move the nozzle back and forth in the rapid sweeping motion typical of spray painting; this will cause skinning.* In practice, all of this occurs fairly rapidly, so the nozzle is slowly moved across the object as the region under the nozzle is observed to be saturated but not yet flooded.
4. Butt adjacent bands closely, before they dry, and avoid overlap.

**Effective concentration of consolidant applied to the object**  
Complete the treatment as follows:

1. Allow the solvent to evaporate completely between each application.
2. Assess the color change and improvement in bonding between each application.
3. Apply successive coats of consolidant to increase, in increments, the final consolidant concentration on the object.

---

## Notes

- 1 This technique was originally demonstrated by Michalski in a workshop titled "The Consolidation of Painted Ethnographic Objects," presented in 1990 by the Getty Conservation Institute, Marina del Rey, California.
- 2 For example, a thin layer of ultramarine on a white background will change from a pale opaque blue to a transparent deep blue glaze. White calcium carbonate on a dark surface will change from an opaque white to a dark gray, or disappear completely.
- 3 For ultrasonic nebulizers, the drop range is between 1 and 5  $\mu\text{m}$  (Shoh 1979:469). For common air (pneumatic) sprayers, mean drop size between 10 and 100  $\mu\text{m}$ , with the smaller droplets, is possible only at very high air flows and pressures (Fair 1979:479). For airless (hydraulic) sprayers or spritzers, the drop range is 200–4000  $\mu\text{m}$  (Fair 1984).

---

## Materials and Suppliers

**From local hardware stores:** ultrasonic humidifier; wet/dry vacuum cleaner; 6 mm ( $\frac{1}{4}$  in.) vinyl tube; screw and bolt.

**From aquarium or pet shops:** Wisa 120 air pump (120 l  $\text{hr}^{-1}$  in water, 200 l  $\text{hr}^{-1}$  in air); air-pump valve.

**From plumbing supply stores:** copper pipe, 13 mm ( $\frac{1}{2}$  in.) in diameter; copper pipe, 19 mm ( $\frac{3}{4}$  in.) in diameter; copper T piece, 19 mm  $\times$  19mm  $\times$  13 mm ( $\frac{3}{4}$  in.  $\times$   $\frac{3}{4}$  in.  $\times$   $\frac{1}{2}$  in.).

**From plastics supply houses:** flexible PVC tubing, 25 mm (1 in.) ID and 28 mm ( $1\frac{1}{8}$  in.) outside diameter (OD); clear flexible PVC tubing, 16 mm ( $\frac{5}{8}$  in.) ID and 24 mm ( $\frac{15}{16}$  in.) OD; low-density polyethylene ("Boston") bottle, 500 ml size; high-density polyethylene Nalgene quick-disconnect pieces, 6.4–7.9 mm ( $\frac{1}{4}$ – $\frac{5}{16}$  in.) or various sizes; Lexan tube, 13 mm ( $\frac{1}{2}$  in.) ID and 16 mm ( $\frac{5}{8}$  in.) OD.

**From electric supply houses:** Powerstat speed control 3PN116B voltage regulator, single phase, 120 V, 50/60 Hz, 10 A—from Electro Sonic Inc., 1100 Gordon Baker Road, Willowdale, Ontario, Canada, M2H 3B3; or

Staco variable transformer no. 09-521-110, 120 V, 0–120–140 V, 50/60 Hz, 10 A; or Minitrol Power Control no. 11-472-75, 120 V, 13 A—both from Fisher Scientific, 2761 Walnut Ave., Tustin, CA 92781.

**From chemical suppliers:** Acryloid B72 acrylic resin (methyl acrylate/ethyl methacrylate copolymer), Rohm and Haas, Independence Mall West, Philadelphia, PA 191052; or Manse Road, West Hill, Ontario, Canada M1E 3T9.

---

## References

- Arnold, David  
1996 Recent advances in mist consolidation of powdery surfaces. In *Abstracts of the AIC 24th Annual Meeting, Norfolk, Virginia, June 10–16, 1996*. Washington, D.C.: American Institute for Conservation of Historic and Artistic Works (AIC).

- Dignard, Carole, Robyn Douglas, Sherry Guild, Anne Maheux, and Wanda McWilliams  
1997 Ultrasonic misting, part 2: Treatment applications. *Journal of the American Institute for Conservation* 36(2).
- Fair, J.  
1984 Liquid-gas systems. In *Perry's Chemical Engineers Handbook*, 6th ed., 18–52. New York: McGraw Hill.
- 1979 Sprays. In *Kirk Othmer Encyclopedia of Chemical Technology*, 3rd ed., vol. 21. New York: Wiley and Sons.
- Guillemard, D., and A. Renard  
1992 Les peintures ethnographiques: Question de pulvéulence. *Conservator* 16:18–22.
- Halpine, S. M.  
1992 Amino acid analysis of proteinaceous media from Cosimo Tura's *The Annunciation with Saint Francis and Saint Louis of Toulouse*. *Studies in Conservation* 37(1):22–38.
- Hansen, E. F., R. Lowinger, and E. Sadoff  
1993 Consolidation of porous paint in a vapor-saturated atmosphere: A technique for minimizing changes in the appearance of powdering, matte paint. *Journal of the American Institute for Conservation* 32:1–14.
- Hatchfield, P.  
1988 The use of cellulose ethers in the treatment of Egyptian polychromed wood. In *Conservation of Ancient Egyptian Materials*, ed. S. C. Watkins and C. E. Brown, 71–78. London: United Kingdom Institute for Conservation, Archeology Section.
- Michalski, S., and C. Dignard  
1993 Consolidation of powdery paint using the ultrasonic mister. Poster session abstract in *Preprints of the ICOM-CC 10th Triennial Meeting, Washington D.C., 22–27 August 1993*, ed. J. Bridgland, 900. Paris: ICOM Committee for Conservation.
- 1997 Ultrasonic misting, part 1: Experiments on appearance change and improvement in bonding. In *Journal of the American Institute for Conservation* 36(2).
- Shoh, A.  
1979 Ultrasonics (high power). In *Kirk Othmer Encyclopedia of Chemical Technology*, 3d ed., vol. 23. New York: Wiley and Sons.
- Weidner, Marilyn Kemp  
1993 Treatment of water-sensitive and friable media using suction and ultrasonic mist. In *The Book and Paper Group Annual*, vol. 12, comp. Robert Espinosa, 75–84. Washington, D.C.: AIC.
- Welsh, E. C.  
1980 A consolidation treatment for powdery matte paint. In *The American Institute for Conservation of Historic and Artistic Works Preprints of Papers Presented at the Eighth Annual Meeting, San Francisco, California, 22–25 May 1980*, 141–50. Washington, D.C.: AIC.

# Poly(2-Ethyl-2-Oxazoline): A New Conservation Consolidant

Richard C. Wolbers, Mary McGinn, and Deborah Duerbeck

THE DOW CHEMICAL COMPANY received, in 1977, the first of a series of patents for a new tertiary amide polymeric material based on the monomer 2-ethyl-2-oxazoline.<sup>1</sup> It was quickly discovered that the new polymer exhibited some unusual physical and chemical properties. Poly(2-ethyl-2-oxazoline) (PEOX) was soluble in a wide range of solvents, including water, and it was miscible with a wide range of common polymeric materials. Even in blends with other miscible polymers, single glass transition temperatures (the temperature at which the mechanical properties of a glassy material begin to change) were often observed. As a miscible polymer, it was expected that PEOX might enhance the adhesion of other polymers to a wider range of substrate materials. PEOX also had the potential for being heat sealable, with a glass transition temperature of 55 °C. As a water-soluble material with a heat-sealing capacity, such applications as a biodegradable adhesive for packaging or cartons were initially suggested. The first comprehensive review of the physical and chemical properties of PEOX was published by Chiu and coworkers (Chiu, Thill, and Fairchok 1986).

## Summary of Properties of PEOX

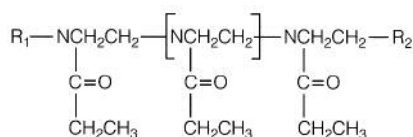

Figure 1  
The structure of poly(2-ethyl-2-oxazoline)  
(PEOX), trade named Aquazol.

The structure of PEOX is given in Figure 1. The polymer is essentially prepared by a cationic ring-opening polymerization of the monomer 2-ethyl-2-oxazoline. Chiu and coworkers (1986) used this synthetic route to produce the polymer in quantities sufficient to physically and chemically characterize its properties. They measured the density of the polymer as 1.14 g cm<sup>-3</sup>. The refractive index was determined to be the same as glass (1.520). Melts of the polymer appeared to be relatively shear stable; that is, when subjected to shearing or mechanical forces for prolonged periods, very little breakdown in viscosity was noted. This resistance to viscosity loss or breakdown seemed to suggest an unusual mechanical stability. When compared to other water-soluble polymers, solutions of PEOX appeared to be several orders of magnitude less viscous at comparable concentrations than the other polymers tested. PEOX was also found to be thermally quite stable (up to 380 °C in air, 400 °C in nitrogen). As mentioned above, the solubility data for the polymer suggested that a broad range of solvents would be useful solubilizers; solubility data from Chiu and coworkers is reproduced in Table 1 for convenience.

Dow licensed production of the polymer in the early 1990s to Polymer Chemistry Innovations, who began producing it on a limited

Table 1 Solubility of Aquazol

$\delta$ (solubility parameter)	Solvent	Solubility
7.0	n-pentane	p
7.4	diethyl ether	p
7.8	diisobutyl ketone	p
8.5	n-butyl acetate	p
8.9	toluene	p
9.3	perchloroethylene	p
9.3	dibutyl phthalate	p
9.3	chloroform	s
9.3	methyl ethyl ketone	s
9.5	ethylhexanol	s
9.6	methyl acetate	s
9.7	methylene chloride	s
9.9	acetone	s
10.0	dioxane	s
11.9	acetonitrile	s
12.7	nitromethane	s
12.7	ethanol	s
13.3	propylene carbonate	s
14.4	methanol	s
23.4	water	s

p = solubility of 2% or less by weight

s = solubility of 25% or more by weight

(from Chiu, Thill, and Fairchok 1986)

scale under the trade name Aquazol, in molecular weight ranges of 50 K, 200 K, and 500 K. To date, the polymer has found limited use as a hot-melt adhesive, and in some pressure-sensitive adhesive preparations. Additionally, it has gained acceptance as a greenware binder because of its clean burnout and nonionic nature. Aquazol has been approved by the FDA for use as an indirect food additive (adhesive).

## Scope of the Present Study

The wide solubility range of PEOX is a potentially attractive property for conservation uses. The possibilities of application or removal of residue using a wide variety of solvents could be a valuable asset in the treatment of complex painted surfaces. Another attractive feature of the polymer is its heat sealability, which takes place in a temperature range (around 55 °C) close to that of a number of synthetic resins currently in use in conservation (BEVA 371, poly[butyl methacrylate], poly[vinyl acetate] mixtures, etc.). As a conservation material, however, questions as to its stability needed to be raised and evaluated experimentally. Was it stable to light aging? Was its appearance altered on exposure? Did it cross-link? Would it oxidize or be difficult to redissolve in time? What were its handling properties? The purpose of this article is to present the results of accelerated

light-aging tests on the resin and to describe a series of test applications to a selected group of painted objects.

---

## Materials and Methods

### Sample preparation and light aging prior to testing

Samples of Aquazol 50 and Aquazol 500 were obtained as dry granular powders.<sup>2</sup> Solutions of each were prepared in deionized water (20% w/v, given as number of grams of solute per 100 ml of solvent), and poured over standard borosilicate glass plates (6.35 cm × 20.32 cm). The cast films obtained on drying were measured for average thickness with a caliper micrometer and determined to be 0.036 mm for Aquazol 500, and 0.037 mm ± 0.005 mm for Aquazol 50 (ten repeat measures). The films were allowed to dry for one week, and then were exposed to accelerated light aging in an Atlas Ci35 Weather-Ometer at a constant 50% relative humidity, 63 °C black panel temperature, under a water-cooled xenon arc lamp (fitted with a type S borosilicate inner filter and a soda lime glass outer filter). The cast films were exposed to a 72-hour lamp "on" period, followed by a 72-hour dark period, and then a second 72-hour lamp "on" period. The total radiant exposure received was estimated to be 280 kJ m<sup>-2</sup>. This value was estimated from the discoloration (yellowing) of a standard polystyrene chip,<sup>3</sup> measured as the increase in the *b* value, or coordinate, of its CIE L\*a\*b color measurement before and after exposure against a standard white background plate, as per SAE J1960 and SAE J1885, industry standard methods for exposure and dosimetry of automotive exterior and interior materials, using water-cooled, xenon-arc-controlled irradiance devices.<sup>4</sup> SAE J1960 specifies a constant irradiance of 0.55 W m<sup>-2</sup> at a wavelength of 340 nm (1.1 W m<sup>-2</sup> at 420 nm) for the xenon arc lamp. Under normal museum exposures (light sources that produce irradiances at UV wavelengths of 75 mW m<sup>-2</sup> or less) (Thomson 1978:23), the total exposure obtained was equivalent to approximately twenty-four years of natural aging.

### Size-exclusion chromatography

As an aid in determining the molecular weights of the Aquazol 50 and 500 materials before and after light aging, a size-exclusion chromatography (SEC) experiment was performed. A column was constructed from a 50 ml glass burette fitted with a Teflon stopcock. A small piece of glass wool was inserted in the burette above the stopcock to retain the exclusion gel slurry. A slurry of Sepharose CL-6B (20% in ethanol) was introduced into the column. Once the column was filled with the slurry, a 1 l reservoir of 0.1 M phosphate buffer (pH 7.5) was attached to the column head, and the buffer allowed to flow by gravity through the column until approximately three column volumes of buffer were passed through it. The flow rate of buffer eluent through the column after this initial equilibration stage was 0.36 ml min<sup>-1</sup>. The void volume of the column (*V*<sup>o</sup>) was determined by measuring the amount of eluent that passed through the column until a standard molecular weight compound, Blue Dextran—which was completely excluded because of its high molecular weight—was eluted. The elution volumes (*V*<sup>e</sup>) for three other standard compounds were determined, to calibrate the column.<sup>5</sup> Column fractions were monitored at a wavelength of 280 nm for the standard compounds with a UV-VIS spec-

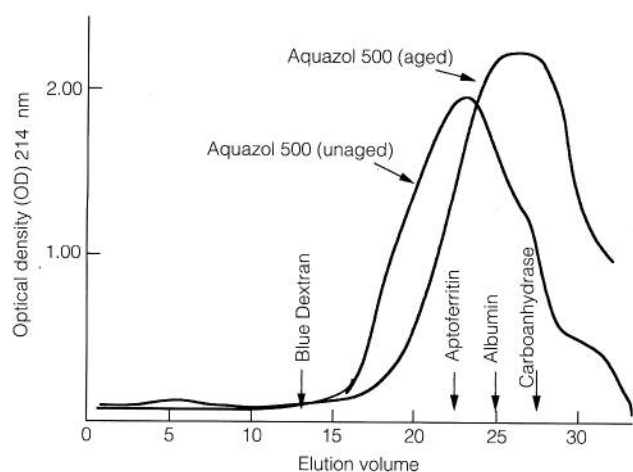

**Figure 2**  
Size exclusion chromatography of aged and unaged samples of Aquazol 500 on a column filled with 500 Sepharose CL-6B.

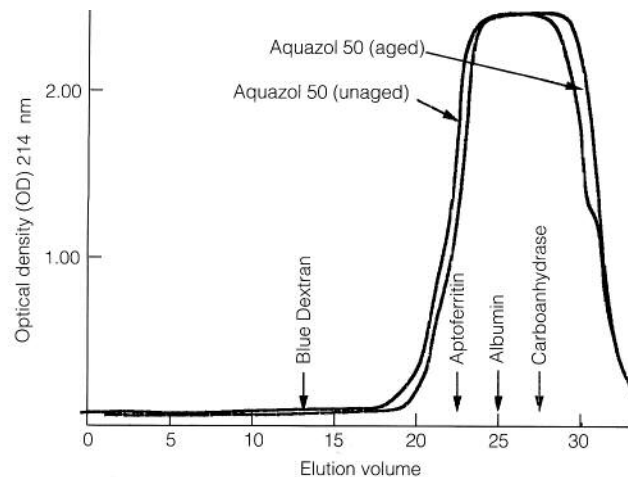

**Figure 3**  
Size exclusion chromatography of aged and unaged samples of Aquazol 50 on a column filled with 500 Sepharose CL-6B.

trophotometer.<sup>6</sup> The expected linear plot of  $\log MW$  versus  $(V^e/V^0)$  was obtained for the standard molecular weight compounds used, thereby confirming that the column was properly calibrated.

Samples of both aged and unaged Aquazol 50 and Aquazol 500 were applied to the calibrated column to determine their molecular weights by exclusion chromatography. The Aquazol samples were applied in 2 ml aliquots of the phosphate buffer and glycerol mixture used for the standard compounds, and at a concentration of  $5 \text{ mg ml}^{-1}$ . Both of the light-aged Aquazol materials appeared to be completely re-soluble in the phosphate buffer and glycerol mixture used for loading them on the SEC column. Their elution volumes ( $V^e$ ) were tracked at a wavelength of 218 nm (the optimal absorption wavelength) with the UV-VIS spectrophotometer. The data obtained are plotted in Figures 2 and 3 for the unaged and aged Aquazol 500 and 50 materials, respectively, as a function of absorbance (optical density units) and of  $V^e$ .

### pH measurements

The pH measurements were performed on 5% (w/v) aqueous solutions of Aquazol 500 and Aquazol 50 in deionized and degassed water, before and after light aging, to check the neutrality of the starting materials in each case and to determine if light aging had produced any ionizable functional groups on the polymers.<sup>7</sup> The pH meter and electrode were recalibrated with standard buffer solutions prior to measurement of the test solutions. A blank pH measurement was initially determined for the deionized and degassed water that was used to dissolve the tested polymers. Three replicate pH measurements were made for each polymer solution type. Results of the pH measurements appear in Table 2.

**Table 2** Results of pH measurements of Aquazol 50 and 500 before and after light aging

	pH before light aging	pH after light aging
Aquazol 50	6.4 (0.1)	6.2 (0.1)
Aquazol 500	6.4 (0.1)	6.2 (0.1)

Values in parentheses indicate standard deviations of measurements.

### Thermogravimetric analysis and differential thermal analysis

In an effort to repeat the observations of Chiu and coworkers regarding the thermal stability of Aquazol 500, and as a way of evaluating its thermal stability after light aging, thermogravimetric analysis (TGA) was performed on three 1 mg samples of unaged and light-aged Aquazol 500,

under nitrogen in glass capillary tubes, at a heating rate of  $10\text{ }^{\circ}\text{C min}^{-1}$ . Results are plotted in Figure 4, as average curves derived from the replicate runs, for the unaged and light-aged samples.<sup>8</sup>

Differential thermal analysis (DTA) was performed on samples of unaged and light-aged Aquazol 50 and 500, in an effort to look for changes in such fundamental polymer characteristics as glass transition temperature ( $T_g$ ), degrees of crystallinity, or specific decomposition patterns or pathways. By looking at any endothermic or exothermic transitions that might occur at elevated temperatures, fundamental structural changes in the polymer after light aging might be inferred. Observed increases in  $T_g$ , for instance, might suggest increased cross-linking in the polymer after light aging. DTA was performed on approximately 1 mg samples of aged and unaged Aquazol 500 and Aquazol 50, in triplicate, in glass capillary tubes under nitrogen, using a DuPont 900 thermal analyzer—at a heating rate of  $5\text{ }^{\circ}\text{C min}^{-1}$ —and standard Chromel Alumel Thermocouples—with the instrument calibrated against gypsum. Results are plotted in Figures 5 and 6, as average curves derived from the replicate runs, for unaged and light-aged samples.

### Re-solubilization tests

In an effort to evaluate the rates of re-solubilizing cast films of Aquazol 50 and 500 in various solvents before and after light aging, a novel solubility test was devised. Typically, past re-solubilization tests have been largely empirical; that is, solvent-laden cotton swabs were rolled or rubbed over test films by hand, and the re-solubilization rates of tested materials judged subjectively. In an attempt to avoid the subjective pitfalls of past testing methods (differential solvent evaporation rates, hand-pressure variations in rubbing or rolling, etc.), a new method was devised, as follows: casting troughs were made from lengths of poly(tetrafluoroethylene) bar stock ( $3.1\text{ mm} \times 25.4\text{ mm} \times 30.5\text{ cm}$ ), each notched lengthwise with a V-shaped trough approximately 1 mm in aperture and 1 mm in depth. One end of each trough was blocked with microcrystalline wax; the opposite end of the bar stock was elevated 12–13 mm to form a slanted, closed-end groove. Each trough was then loaded with a single line of borosilicate

Figure 4  
Thermogravimetric analysis of Aquazol 500  
before and after aging.

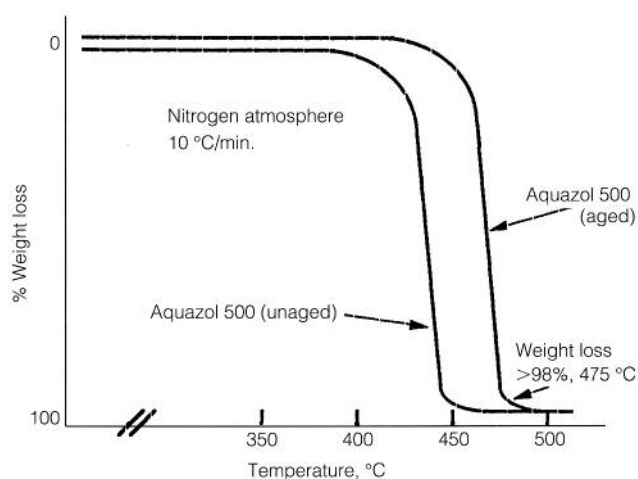



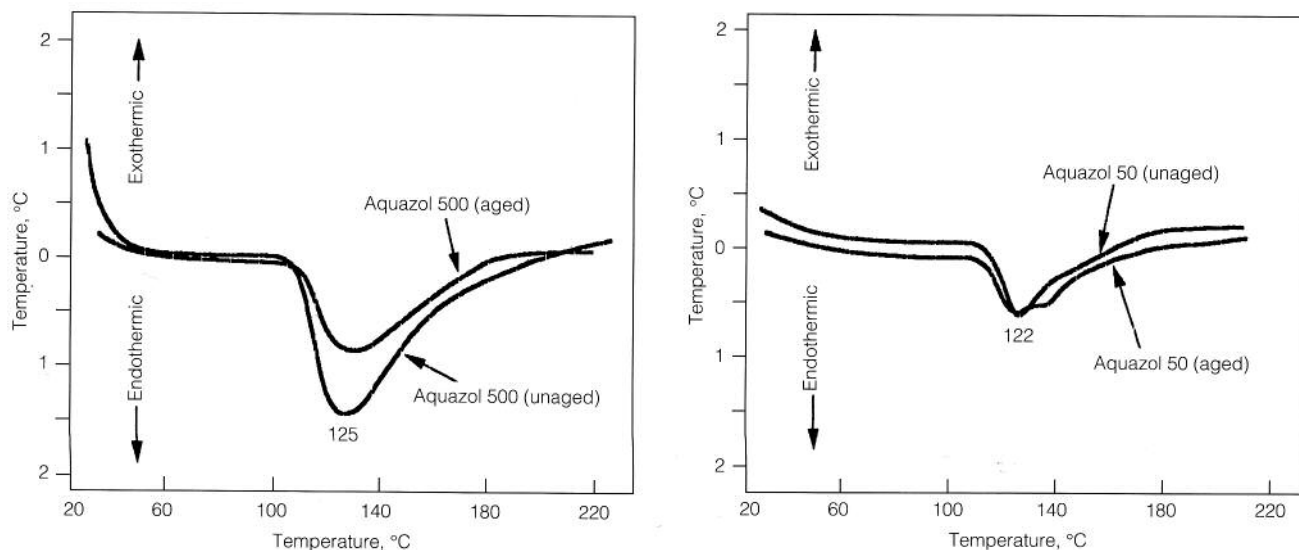

Figure 5  
Differential thermal analysis of aged and unaged samples of Aquazol 500.

Figure 6  
Differential thermal analysis of aged and unaged samples of Aquazol 50.

glass spheres<sup>9</sup> that just touched one another and were held in contact by gravity. Over the lines of arranged glass beads, 10% solutions of unaged Aquazol 50 and 500 in deionized water were applied with a disposable pipette. Excess solution was drawn off by pipette, leaving a thin, uniform coating on the beads and at the points of contact between them. The coated beads were allowed to air dry on the slanted forms for three days at 25 °C to form "strings" of adhered beads. Half of the coated strings of beads were light aged under the conditions described earlier in "Sample preparation and light aging prior to testing."

For this test, pairs of coated, unaged or light-aged beads were removed from the longer strings, and were then ready to be used as test substrates in re-solubilization tests. A pair of beads would be held in a given solvent solution (100 ml reagent grade) by clamping one bead of the pair with a pair of Rankin forceps.<sup>10</sup> The suspended pair of beads was immersed in the test solvent and stirred on a magnetic stirring plate<sup>11</sup> at a speed setting of 4; the time they took to separate (one bead falling free from the clamped bead) was recorded in minutes. The test was repeated five times in each solvent for these time-to-separation measurements. Results for both unaged and light-aged Aquazol 50 and Aquazol 500 are summarized in Figure 7, in the form of histograms indicating the time-to-separation ranges for the five tests in each category.

### Viscosity measurements

A Brookfield viscometer, model LVT, equipped with spindle no. 1, was used to measure the viscosity of test Aquazol solutions at 25 °C, before and after light aging. Viscosity measurements were performed to help determine the molecular weights of the light-aged Aquazols; using the Mark-Houwink equation previously determined for the polymer by Chiu and coworkers (1986), viscosities that were measured after light aging could be useful to suggest whether the polymers were increasing or decreasing in molecular weight after aging. Only two replicates were performed during these viscosity measurements on each polymer sample, due to the relatively large amounts of material required to make up the test solutions. Results are recorded in Figure 8 and Table 3.

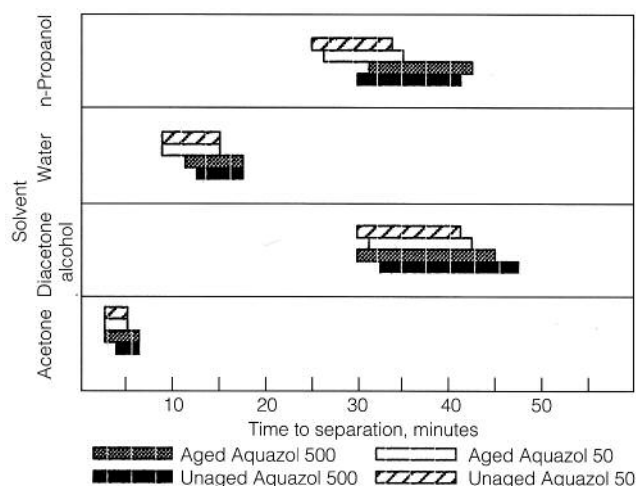

Figure 7  
Time to separation (resolubility) of Aquazol 50 and 500, both aged and unaged.

Figure 8  
Aqueous solution viscosity vs. concentration of Aquazol 500 at 25 °C, before (○) and after (□) aging.

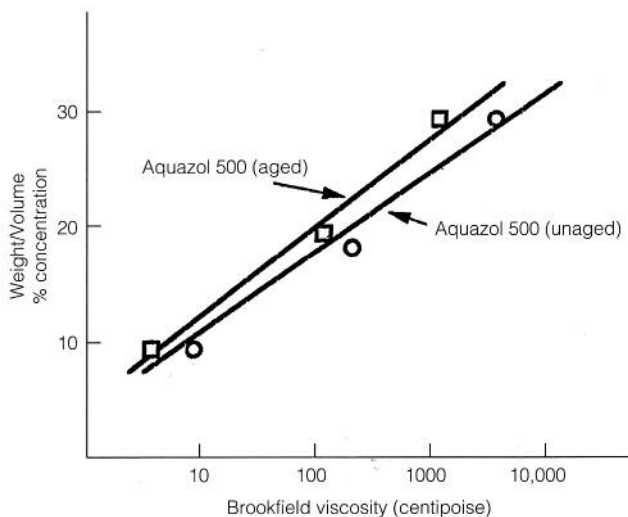

Table 3 Estimated molecular weights of Aquazol preparations before and after aging

Sample	Intrinsic viscosity [ $\eta$ ] dl/g	Calculated molecular weight
Aquazol 50	0.3	50,000
Aquazol 50 (aged)	0.27	44,000
Aquazol 500	0.83	300,000
Aquazol 500 (aged)	0.68	210,000

Estimates were made using the Mark-Houwink equation derived by Chiu and coworkers:  $[\eta] = 6.5 \times 10^{-4} M^{0.56}$ .

## Color measurements

Color measurements were performed on cast films of Aquazol 50 and 500 (described in the section “Sample preparation and light aging prior to testing”) on glass backed with a standard white reference plate, before and after light aging in the Weather-Ometer. Color coordinate values (five replicate measures for each resin type) were measured and calculated using a Minolta C100 Chroma Meter (a tristimulus colorimeter) equipped with a DP100 microprocessor unit. Results are summarized in Table 4.

## Infrared spectroscopy

In an effort to establish whether any gross chemical changes might have occurred in the polymer preparations after light aging (e.g., oxidation, deamination, etc.), Fourier-transform infrared (FT-IR) spectra were obtained for Aquazol 50 and Aquazol 500 before and after light aging.<sup>12</sup> The unaged and light-aged Aquazol samples were dissolved in chloroform and cast as thin films before their spectra were run.

## Tensile strength measurements

Tensile strength measurements were performed on 25 mm-wide strips of cast films ( $0.450 \text{ mm} \pm 0.005 \text{ mm}$ , five replicates) of 20% solutions of Aquazol 500 in acetone, on silicone release Mylar sheets.<sup>13</sup> Samples of the films were preconditioned in closed chambers over saturated salt solutions (KOH,  $\text{MgCl}_2 \cdot 6\text{H}_2\text{O}$ , and  $\text{NaNO}_3$ ) for twenty-four hours, prior to testing, to equilibrate them to a variety of relative humidity (RH) conditions. The samples were removed from their conditioning chambers and immediately tested on the Scott apparatus in an environmentally controlled testing room conditioned to ASTM standard D1776 (70 °F, 65% RH).<sup>14</sup> Results are summarized in Table 5.

## Results and Discussion

The test films were remarkably unchanged visually after light aging. Color measurements before and after light aging indicated no significant difference in terms of discoloration (Table 4). Specifically, no positive increases were noted in the measured *b* coordinate values ( $L^*a^*b$  notation)

Table 4 Color measurements on aged and unaged films of Aquazol 50 and 500 on glass

Sample	CIE L*a*b color coordinates		
	L	a	b
Aquazol 500	96.97 (.09)	20.97 (.05)	-8.60 (.02)
Aquazol 500 (aged)	96.87 (.09)	20.80 (.02)	-8.34 (.05)
Aquazol 50	96.71 (.15)	20.97 (.05)	-8.63 (.08)
Aquazol 50 (aged)	96.49 (.10)	20.93 (.03)	-8.27 (.08)

Standard deviations for each value are given in parentheses.

Table 5 Tensile strength data for Aquazol 500 conditioned to various RH levels

RH	Elongation to yield $\epsilon_y$ (%)	Yield stress $\sigma_y$ ( $\text{kg m}^{-1}$ )	Elongation to break $\epsilon_B$ (%)	Breaking stress $\sigma_B$ ( $\text{kg m}^{-1}$ )
8%	12	44.62	380	53.57
33%	25	40.17	450	49.10
73%	50	17.85	550	26.78

that would indicate yellowing of the materials. (By way of reference, the standard polystyrene chip that was included as a dosimetry measuring device in this experiment *did* yellow on light aging, to a pale transparent yellow color, equivalent to 13.5 *b* coordinate units.) The exposed samples remained essentially transparent. Again, any decrease in transparency would have been indicated by a decrease in the measured *L* values over the standard white plates. It should be noted, however, that after light aging, the Aquazol 50 samples exhibited a distinct surface-texture change, a kind of surface reticulation (“orange peel”), that was not present on the unaged films. This effect was attributed to local water spotting and a concomitant re-forming of the test film surfaces during light aging (water droplets were blown up onto the test films from a water reservoir bath at the bottom of the aging chamber by a circulating fan in the chamber).

The FT-IR data obtained on the Aquazol samples before and after light aging were essentially unchanged. As expected for a complex aliphatic tertiary amide, major absorption bands were noted at  $2998\text{ cm}^{-1}$ ,  $2950\text{ cm}^{-1}$ , and  $2890\text{ cm}^{-1}$  ( $-\text{CH}_2-$ ,  $-\text{CH}_3$ ), along with a sharp band at  $1660\text{ cm}^{-1}$  (tertiary amide). Several minor bands ( $1250\text{ cm}^{-1}$ ,  $1209\text{ cm}^{-1}$ , and  $769\text{ cm}^{-1}$ ) were present as well, suggesting the presence of an aromatic sulfonic acid, or sulfonate ester. Chiu and coworkers indicated that methyl tosylate was used in the original preparation method for PEOX as an initiator (in ratios as high as 200:1, monomer to initiator), and it may be that this material was utilized in the preparation of the present polymeric materials. It is conceivable that methyl tosylate or its hydrolysis product, *p*-toluene sulfonic acid, could account for the added absorption bands noted in the FT-IR spectra (but this can only be surmised at this point). In any event, the infrared (IR) spectra before and after light aging, for both Aquazol 50 and 500, were virtually identical. Following exposure, no

additional absorption bands that might be indicative of oxidative processes, or other gross deteriorative processes, were noted in the IR spectra. In particular, the characteristic carbonyl absorption band at approximately  $1740\text{ cm}^{-1}$  was not present before or after the light aging; the appearance of such a band after aging might have been taken as indicative of the growth of oxidation products in the polymer.

The pH of solutions of Aquazol 50 and 500 made prior to light aging were identical ( $6.4 \pm 0.1$ ). This value appears to be consistent with the nonionic character of the polymer. The pH of solutions made from aged films of the Aquazol 50 and 500 materials essentially yielded the same value ( $6.2 \pm 0.1$ ). The contribution to the pH from atmospheric  $\text{CO}_2$  in both cases was minimized experimentally by making up all solutions in degassed and deionized water.

The DTA data for both Aquazol polymer preparations tested yielded similar plots before and after exposure (Figs. 5 and 6). Under a nitrogen atmosphere, Aquazol 500 exhibited a single endothermic peak at  $125\text{ }^\circ\text{C}$ ; the Aquazol 50 material exhibited a single peak centered at  $122\text{ }^\circ\text{C}$ . Presumably, the loss of sorbed water and a concomitant crystalline fusion reaction in the polymer in both cases account for these generally observed, single, broad peaks that begin just above  $100\text{ }^\circ\text{C}$ . It is interesting to note that in both cases the endothermic peaks broaden somewhat on exposure, or resolve themselves into trailing peaks. This broadening is more pronounced with the Aquazol 50 material, which nearly resolved itself into two trailing peaks under the applied temperature gradient. Drops in the molecular weight of the polymers might account for these observed endothermic phenomena. In any event, no exothermic peaks were noted with either of the Aquazol preparations, and there were no signs of decomposition up to the maximum test temperature of  $220\text{ }^\circ\text{C}$ . The extrapolated  $T_g$ 's derived from the DTA plots remained at or below the value reported by Chiu and coworkers ( $55\text{ }^\circ\text{C}$ ) for samples cast from aqueous solutions of the polymer—which suggests, at least, that no increases in molecular weight were likely to have occurred during exposure. The TGA analysis performed on the Aquazol 500 material after aging confirmed the thermal stability of the polymer (Fig. 4). The data of Chiu and coworkers suggested a stability of the polymer to greater than  $400\text{ }^\circ\text{C}$ ; the light-aged material appeared, if anything, to be more stable against thermal decomposition:  $20\text{ }^\circ\text{C}$  higher than the value reported for the unaged material.

When standard solutions of unaged and light-aged Aquazol 500 were compared, solution viscosities did appear to drop on light aging (Fig. 8). If the Mark-Houwink equation for the polymer, deduced by Chiu and coworkers, is correct, then the intrinsic viscosity of the exposed samples of both Aquazol 50 and Aquazol 500 appears to decrease, suggesting drops in molecular weight in both cases on aging.

Size exclusion chromatography experiments (Figs. 2 and 3) also tended to indicate that both Aquazol preparations dropped in molecular weight (MW) after light aging. In the case of the Aquazol 50 material, the molecular weight drop was only slight; however, the molecular weight drop of the Aquazol 500 was substantial. The elution position for the Aquazol 50 material, both before and after light aging, was as expected for a polymer with a molecular weight of about 50 K, when compared to standard protein markers run over the same column. The unaged Aquazol 500 material appeared to have an MW closer to 300 K initially; the bulk of it appeared to elute just after the standard marker apoferritin (MW = 443 K).

On light aging, a substantial portion of the Aquazol 500 material appeared to drop in molecular weight to approximately 50 K, and eluted just after the albumin marker (MW = 66 K). With light-aged samples of both Aquazol 50 and Aquazol 500, no insoluble matter (gel fraction) was evident in the material applied to the column heads, and no material was eluted with the breakthrough, or excluded, column fraction. (The nominal exclusion limit for the Sepharose CL-6B used to pack the column is an MW of 1.5 M.)

These results tend to suggest that, under the light-aging conditions imposed, both Aquazol preparations seemed to decrease in size, rather than cross-link or increase in size. In the case of the Aquazol 500, the drop from an initial 300,000 daltons to around 50,000 indicates a chain scission (if that is what is occurring) at a frequency of 1:600 monomer units. This same frequency of chain scission seemed to be occurring in the SEC data from the Aquazol 50 (and is reflected in the only slight drop detected in its molecular weight on aging). It is also interesting to note that, at 218 nm (the wavelength used to detect the eluting polymer), end groups on the polymer may be responsible, in particular, for the increased absorption seen during the SEC experiments. After light aging, the lower molecular weight of the Aquazol 500 gave an overall stronger molar absorption than for the same weight of unaged material on the column.

Re-solubilization tests (Fig. 7) revealed essentially two important features. First, on light aging, both of the Aquazol preparations remained essentially re-soluble in the same solvents in which they were initially soluble. Second, the rates of re-solubility, surprisingly, were not ordered or determined by solvent polarity alone. Water turned out to be a slower (and therefore "poorer") re-solubilization agent for both Aquazols than acetone, for example, which turned out to be the best (fastest) re-solubilization agent tested. It should be noted that during the tests it was observed that, in general, the slower a particular solvent was at redissolving the Aquazol materials, the wider or broader the range of time-to-separation measurements. Nevertheless, the test method was acceptable because predictable film thicknesses could be generated over and between the glass beads (an inert support) used for the test. More important, the traditional tests for re-solubility, based on the subjective application of solvents with the swab test and hard-to-control variables, could be avoided. The only pressure exerted on the coated test-bead pairs was from the agitation of the test solvent itself by the magnetic stirring apparatus; stirring rates could be easily controlled. Clear end points were always marked by a separation of the two beads that composed the test pair, so there was never a question as to when a certain amount of material had dissolved.

While Chiu and coworkers presented data comparing adhesive properties of Aquazol 500 on various substrates with poly(vinyl pyrrolidone) (PVP) and poly(vinyl alcohol) (PVOH) polymer preparations (the so-called Scotch Tape test), the tensile strength measurements done in association with this study revealed two other important working properties of Aquazol. Since Aquazol is a water-soluble polymer, its moisture absorption—as a function of the ambient relative humidity—could potentially affect its strength as a material. Although films of the polymer were tested at only a few specific RH levels (Table 5), the data indicated that a family of stress/strain curves were generated as a function of RH. Generally, Aquazol exhibits a Young's modulus characteristic of an extremely plastic material. Yield stresses ( $s_y$ ) were quite low, varying from

17.85 kg m<sup>-1</sup> at 73.8% RH to only 44.62 kg m<sup>-1</sup> at 8% RH. Concomitant elongation to yields ( $e_y$ ) were small, varying from 50% at 73.8% RH, to 12% at 8% RH. Replicate measures suggested that yield stresses and strains did change with RH, and generally increased slightly with decreasing RH. Nevertheless, the Aquazol films were extremely plastic materials even at low RH levels. Elongation-to-break values ( $e_b$ ), even at 8% RH, were enormous (380%) at only slightly increased breaking stresses. In comparison with other adhesive materials traditionally used for paint consolidation on wooden substrates, this retention of plastic character, even at low RH levels, makes it a much better choice than, for example, a traditional hide glue which may have an elongation-to-break of only 2–3% at similar low RH values.

---

## Case Studies

In an effort to evaluate the less tangible, but equally important, practical working or handling properties of Aquazol 50 and 500 solutions as consolidants, three painted wooden objects from the Winterthur collection were chosen for testing. These objects had decorative materials that needed consolidation. Only small areas on each object received treatment with the Aquazol preparations; the majority of the surfaces requiring consolidation are to be treated with more conventional materials.

**Settee** (Winterthur 57.0957). This piece is part of a set with side chairs, originally belonging to Governor and Mrs. Joseph C. Yates of New York. It was constructed sometime between 1800 and 1810, possibly in the Albany area. The piece exhibited pinpoint flake losses over most of the decorative surfaces; generally, these losses closely followed the grain pattern of the wood substrate. The immediate need was for consolidation of the flaking paint and preservation of the design materials. Additionally, however, once the design materials were stabilized, there was a curatorial interest in cleaning the grime-laden paint surface. The goal of the conservation treatment, therefore, was to consolidate the massive amount of flaking paint with a material that would not interfere with or complicate later stages of restoration (i.e., cleaning).

**Armchair** (Winterthur 57.0973). This armchair is believed to have been constructed in New York City, between 1810 and 1820. Localized areas of paint cleavage were obvious over the surface of the armchair; the losses seemed to be associated more with acute damage to the armchair, along with a history of rough use, rather than an incipient cleavage problem. As with the settee previously mentioned, the immediate conservation need was to consolidate existing design materials. The consolidant would have to be “gap-filling” or sufficiently substantial to secure the loose design materials because of the rather thick, or heavy, off-white paint layer. The curatorial goal at this point was stabilization only; however, cleaning, compensation, and limited inpainting might be attempted at some later point. Whatever the material introduced, it would be difficult to reverse; moreover, it would have to allow for, and be compatible with, future compensating and inpainting materials.

**Carved wooden eagle** (Winterthur 59.2354). The immediate conservation need for this object—attributed to Wilhelm Schimmel, Carlisle, Pennsylvania, between 1865 to 1890—was consolidation of paint that was poorly adhered to underlying paints; no restoration beyond stabilization was planned. The need for a consolidant that would penetrate effectively between paint layers was paramount. Since no further restoration work

would be done on the object, its surface appearance after consolidation was critical to its representation in the collection.

### Summary of test consolidation treatments

Solutions of Aquazol 50 were prepared in working concentrations that varied from 10% to 25% (w/v) in water. Solutions were also made in the same weight percentage ranges with water and ethanol blends of up to 10% solvent (v/v). Aqueous solutions of Aquazol 500 were also evaluated at working concentrations of 10–20% of the polymer in water only, and in water-ethanol blends of up to 10% solvent (v/v). Initial consolidation tests were done by applying the polymer solutions by brush, allowing the consolidated areas to dry for a day, and then probing these areas to gauge the effectiveness of the treatment. At this point, no reactivation or heat-sealing properties of the polymers were exploited; only their effectiveness as direct consolidants was evaluated. Initially, a numerical “rating” system was used to evaluate the effectiveness of the various test solutions in each of four specific categories pertaining to working characteristics; ability to flow and penetrate; ability to “relax” flakes; overall security on drying; and visual effect on surrounding design materials.

In summary, it was noted that solutions of Aquazol 50 and 500 in water alone actually penetrated less effectively than aqueous solutions of the polymers that contained small amounts of ethanol. Apparently, the slight decrease in surface tension effected with the added alcohol was useful in allowing for a more complete penetration on the two objects with primarily paint-to-wood adhesion problems (i.e., the settee and the armchair). A 20% solution of Aquazol 500 in a 1:10 ethanol-water blend gave the best results on all three objects. The addition of the alcohol was required for the Schimmel eagle to maximize the penetration into and consolidation of the areas of paint-to-paint cleavage.

The widespread paint cleavage on the settee necessitated that the most friable areas be consolidated by brushing this mixture over both paint and loss areas. After allowing the treated areas to dry, the excess consolidant was successfully removed with water only, even to the point of removing surface grime without any apparent loss of consolidation. The use of a water-soluble consolidant in this way suggests that follow-up aqueous cleaning methods can be used over surfaces consolidated with Aquazol without immediately undoing the consolidant.

In general, it was also noted that more than one application of the Aquazol 50 solutions was required to secure thick paint layers onto the porous wood substrate materials (e.g., the armchair). The initial solutions apparently soaked into the porous wood substrate on application and did not fill the gap between loose paint and the wood; thus, additional applications were required to effect a satisfactory consolidation. The solutions containing Aquazol 500 fared much better in this regard; they generally achieved an effective consolidation with a single application, regardless of the substrate.

---

### Conclusion

The experimental results seem to confirm the observations made by Chiu and coworkers (1986) as to the thermal stability of poly(2-ethyl-2-oxazoline). Viscosity, thermal, and SEC data after light aging suggest that the polymer may tend toward depolymerization rather than cross-linking. The

SEC data seem to be the most telling indicator of this tendency in the present study. From the standpoint of reversibility, or ease in re-solubilization, this tendency may still recommend the polymer as a potential adhesive in conservation. When compared to the aging properties of Acryloid B72 (a standard polymer already used in conservation as a coating or adhesive material) and its tendency to cross-link on aging (Feller 1977), polymers such as Aquazol that tend toward depolymerization may pose less risk in terms of becoming insoluble with age.

However, if the observed chain scission frequency is correct (1 in 600), then preparations of the polymer much greater than 50,000 to 60,000 daltons, used in adhesive situations, may suffer failures concomitant with even this low depolymerization rate. From the tensile strength data, Aquazol appears to be a weak adhesive and may only lend itself to applications where weak forces are at work on adhesive joints. In the present context, the material seemed to perform well as a paint consolidant on wood or paint substrates. Tensile strength data seemed to suggest that, even at low RH levels, the polymer remained very plastic in character. This lack of sensitivity to RH compares favorably with traditional natural consolidants (e.g., hide glue) that may embrittle at low RH levels.

Other characteristics of the polymer that are promising for conservation are the lack of discoloration in the light-aged samples, the water-soluble nature of the resin from a toxicity and safety standpoint, and the absence of a solvent smell.

Certainly, more experimentation should be pursued with this new material. Future directions for research could include evaluating its stability and performance in the context of materials commonly found in painted artifacts. Another avenue of research could (and should) be obtaining and evaluating preparations of the polymer that are methyl tosylate free.

---

## Acknowledgments

The authors gratefully acknowledge the help of Jose Alvarez in the Analytical Department of the Winterthur Museum; Robert Trent, former curator of furniture at the Winterthur Museum; and Fran Mayhew at the University of Delaware, Textile Science Department.

---

## Notes

- 1 Chamberlin, T. A. 1977. Madison N.L. U.S. Patent 4 001 160.
- 2 Aquazol 50 from lot no. 930330; Aquazol 500 from lot no. 930325 (see Materials and Suppliers).
- 3 Polystyrene chips, 50 mm x 89 mm, from lot no. 1 (see Materials and Suppliers).
- 4 Society of Automotive Engineers, Inc., 400 Commonwealth Drive, Warrendale, PA 15096. Report, issued June 1989, as SAE J1960: Accelerated Exposure of Automotive Exterior Materials Using a Controlled Irradiance Water-Cooled Xenon Arc Apparatus; Chevrolet-Pontiac-Canada Group, Headquarters, General Motors Corporation, 30001 Van Dyke Avenue, Warren, MI 48090-9020. Report issued December 1989 as SAE J1885: Polystyrene Reference Plastic Exposure Data.
- 5 Standard molecular weight compounds were obtained in kit form (see Materials and Suppliers). The column was calibrated with the Blue Dextran (2 mg ml<sup>-1</sup>, MW 2,000,000), apoferritin (10 mg ml<sup>-1</sup>, MW 443,000), albumin (10 mg ml<sup>-1</sup>, MW 66,000), and carbonic anhydrase (3 mg ml<sup>-1</sup>, MW 29,000) provided in the kit. Aliquot solutions (2 ml) of these compounds in the eluting phosphate buffer were applied individually to the column (with the addition of 5% glycerol as a loading aid, as per Sigma Technical Bulletin no. GF-3), and their elution profiles were tracked.



- 6 A Perkin Elmer (Lambda 4C CUV-3) scanning spectrophotometer was used.
- 7 A Corning (model 125 Digital) pH meter equipped with a Corning general purpose combination electrode (model no. 476531) was used to measure the pH of test solutions.
- 8 Analyses were done on a DuPont 950 thermogravimetric analyzer. The capillary tubes used were DuPont, no. 900302, 2 mm diameter.
- 9 The glass spheres (which were 5 mm in diameter) were acid washed, rinsed, and air dried prior to use.
- 10 The forceps were 15.87 cm in length (Fisher Scientific, Inc., cat. no. 13-812-45).
- 11 A Corning (model PC-353) magnetic stirrer was used in this study, with a 12.7 mm × 7.9 mm octagonal Teflon-coated stir bar (Fisher Scientific, Inc.).
- 12 An Analect (model RFX-65) FT-IR microscope, equipped with a diamond anvil sample cell, was used (Spectratech model no. 0042-444, Stamford, CT).
- 13 A Scott CRE-500 tensile strength tester was used for the strength measurements in this experiment (GCA/Precision Scientific Co.).
- 14 American Society for Testing and Materials, 1916 Race Street, Philadelphia, PA 19103.

---

## Materials and Suppliers

**Aquazol 50 and Aquazol 500**, Polymer Chemistry Innovations, Inc., 1691 West College Ave., State College, PA 16801.

**glass spheres** (cat. no. 11-312C), Fisher Scientific, Inc., 711 Forbes Ave., Pittsburgh PA 15219-4785.

**molecular weight compounds kit** (cat. no. MW-GF-1000), Sigma Chemical Co., St. Louis MO 63178.

**polystyrene chips**, Test Fabrics, Inc., P.O. Box 420/200 Blackford Avenue, Middlesex, NJ 08846-0414.

**Sepharose CL-6B** (cat. no. CL-6B-200), Sigma Chemical Co.

---

## References

- Chiu, T. T., B. Thill, and W. J. Fairchok  
 1986 Poly(2-ethyl-2-oxazoline): A new water and organic soluble adhesive. In *Water Soluble Polymers*, ed. J. E. Glass, 426–33. Advances in Chemistry no. 213. Washington, D.C.: American Chemical Society.
- Feller, R. L.  
 1977 Stages in the deterioration of organic materials. In *Preservation of Paper and Textiles of Historic and Artistic Value*, ed. C. Williams, 314–35. Washington, D.C.: American Chemical Society.
- Thomson, G.  
 1978 *The Museum Environment*. London: Butterworths.

# Contributors

**David Arnold** received his B.A. in American studies from Michigan State University. He has worked as an intern at the Henry Ford Museum, the Detroit Institute of Arts, the Society for the Preservation of New England Antiquities, Houston Museum of Fine Art (Bayou Bend Collection), and the Philadelphia Museum of Art. Arnold specialized in the conservation of joined wooden objects at the Winterthur Museum/University of Delaware Art Conservation Program, where he received his master's degree in art conservation in 1994. He was a J. Paul Getty intern in furniture conservation at Colonial Williamsburg in 1995 and joined the Society for the Preservation of New England Antiquities as conservator of furniture in 1996.

**Christopher C. Augerson** received his M.A. in art conservation from the State University College at Buffalo in 1992. From 1992 to 1993, he was an advanced intern in the conservation of traditional European polychrome sculpture at the Fine Arts Museums of San Francisco and, from 1994 to 1995, in objects conservation at the Saint Louis Art Museum, where he focused on the conservation of European and Oceanic painted wooden artifacts.

**Cristina Avila** received her B.A. in history from the Federal University of Minas Gerais, a specialized degree in Baroque culture and art from the Federal University of Ouro Preto, and her M.Sc. in history from the University of São Paulo. She has worked as an art historian for several state and private organizations responsible for cultural property in Minas Gerais. She is currently working as an art history consultant. She is also currently the president of the Center of Studies of the Baroque in Minas Gerais and the editor of the Journal *Barroco*, published by the Center.

**Jennifer Baker** received her Master of Arts degree in furniture conservation from the Smithsonian Institution's Furniture Conservation Training Program. After completing an internship and a Kress Fellowship in the conservation laboratory of Shelburne Museum, Vermont, she established a private conservation practice in Burlington, Vermont. Baker is an associate member of the American Institute for Conservation.

**Margaret J. Ballardie** completed four years of study in painting and sculpture, and three years in the conservation of easel paintings. In 1976, she joined the Conservation Department at the City and Guilds of London Art School as a tutor and, from 1981 to 1984, was head of the department. She is currently working on private commissions and is continuing research into the history and methods of the decorative arts, including gesso work, gilding, *verre églomise*, lacquer, and japanning.

**Deborah Bigelow** earned her graduate degree in furniture restoration from the London College of Furniture and, returning to New York, established Deborah Bigelow Associates in 1981, a company that has since developed a distinguished practice in the conservation treatment of decorative furniture finishes, consulting for major museums and private collections across the United States. Bigelow was the project director for the AIC's 1991 proceedings volume, *Gilded Wood: Conservation and History*, based on the 1988 Gilding Conservation Symposium.

**Mitchell Hearn Bishop** studied painting, photography, and ethnobotany. He joined the staff of the J. Paul Getty Museum in 1979 and has worked in several of the entities of the J. Paul Getty Trust. Currently, he is a research coordinator for the Documentation Program of the Getty Conservation Institute. He has a long-standing interest in the ethnobotany of material culture and in the history of conservation.

**Ian C. Bristow** is an architect who specializes in the repair of historic buildings. He developed expertise in historic architectural color in the United Kingdom, through a research project at the University of York from 1975 to 1978, and since then has been in private practice advising on the investigation and re-creation of historic color schemes of seventeenth-century and later dates.

**Susan L. Buck** is a Ph.D. candidate in art conservation research at the University of Delaware. While she was conducting this research she was furniture conservator at the Society for the Preservation of New England Antiquities (SPNEA) Conservation Center in Waltham, Massachusetts. She received her M.S. from the University of Delaware/Winterthur Program in Art Conservation, her M.B.A. from Boston University, and her B.A. in studio art from Williams College. She is particularly interested in understanding and treating painted and gilded objects, using the information provided by cross-sectional microscopy paint analysis and pigment identification.

**Marie-Claude Corbeil** received her B.Sc. in chemistry from Université de Montréal. She then specialized in inorganic chemistry and completed, at the same university, a master's program in 1984 and a Ph.D. program in 1987. She has worked in the Analytical Research Services Division of the Canadian Conservation Institute (CCI) since 1988, performing analyses of museum objects, and is currently a senior conservation scientist. She was CCI's coordinator for the Ursuline Chapel project and was the CCI representative on the project advisory committee.

**Carole Dignard** graduated from the University of Ottawa, receiving her B.Sc. degree in physics and Italian in 1981 and an honors B.A. degree in Classical studies in 1983. She received her master's degree in art conservation from Queen's University in 1986, specializing in the conservation of objects. She has been working in the Objects Section of the Canadian Conservation Institute since 1988 and is now senior assistant conservator.

**Valerie Dorge** has worked as a coordinator in the Training Program of the Getty Conservation Institute since 1992. She has organized a variety of training activities for the Institute nationally and internationally and has contributed conservation expertise to GCI projects in Benin, Mexico, and Belize. From 1980 to 1992, she was a wooden objects conservator at the Canadian Conservation Institute, with a special interest in painted surfaces. She is currently coordinator of the Furniture and Wooden Objects Group of the ICOM Committee for Conservation, is a professional associate of the AIC, and was program chair of the AIC Wooden Objects Group's 1994 symposium, *Painted Wood: History and Conservation*, on which this publication is based.

**Deborah Duerbeck** received her M.S. degree in art conservation from the Winterthur/University of Delaware Program in Art Conservation in 1993. She is an assistant conservator at Art Conservation and Technical Services in Baltimore, Maryland.

**David Erhardt** holds a bachelor's degree in mathematics and chemistry from the University of Miami (1972) and a Ph.D. in organic chemistry from the University of Maryland (1977). He was a medical research associate at George Washington University from 1978 to 1979. He joined the Conservation Analytical Laboratory of the Smithsonian Institution in 1979, and is currently a senior research chemist.

**Merri M. Ferrell** is the curator of the Carriage Collection at the Museums at Stony Brook, New York, where she has worked since 1982. She is an advocate for the preservation of original finishes and materials of horse-drawn vehicles and has supervised the conservation of numerous vehicles and several hundred documents and drawings related to the carriage industry in the collection. She is an associate member of the American Institute for Conservation.

**Andrea M. Gilmore** is the director of the New England regional office of Building Conservation Associates. She is a graduate of the Historic Preservation Program at the Graduate School of Architecture, Planning and Preservation at Columbia University. She is the former director of Architectural Services at the Society for the Preservation of New England Antiquities (SPNEA) Conservation Center. Prior to joining SPNEA, she worked for eight years as an architectural conservator at the National Park Service North Atlantic Historic Preservation Center. She specializes in the study of architectural paints, and her paint studies include the Old South Meeting House in Boston, Massachusetts; the Old State House in Hartford, Connecticut; the Maine State House in Augusta, Maine; Sagamore Hill in Oyster Bay, New York; and Sheldon Library at Saint Paul's School in Concord, New Hampshire.

**Renate Gold** studied art history, ethnology, and archaeology at the University of Würzburg from 1978 to 1986. She studied in Florence in 1982, and in 1986 completed her master's thesis on Historic Photography. From 1986 to 1993, Renate was a scientific staff member at the Germanic National Museum, Nuremberg. Since 1993, she has worked on her doctoral dissertation, "Bismuth Painting," at the University of Würzburg.

**Deborah S. Gordon** has worked as a restoration coordinator and architectural conservator for the New York State Bureau of Historic Sites for more than fifteen years. During this time, she has done extensive analysis of both interior and exterior finishes at the Olana estate.

**Eric F. Hansen** is an associate scientist who joined the Getty Conservation Institute in 1985. He received his M.S. in organic chemistry from the University of California, Irvine, and is currently pursuing studies of architectural sculpture of the Ancient Maya at the University of California, Los Angeles, as a C.Phil. in archaeology. His research interests include the deterioration of natural materials, the factors affecting the treatment of painted objects, and the properties of polymers used in conservation. He was chair of the American Institute for Conservation of Historic and Artistic Works (AIC) subgroup on Research and Technical Studies in 1993 and became a fellow of the AIC in 1992.

**Mark A. Harpainter** began restoring furniture in 1975, apprenticing with a private dealer of antiques in California. He received his B.F.A. from the California College of Arts and Crafts in Oakland, California, in 1978, and a graduate degree in furniture restoration from West Dean College in England in 1982. He has operated a private furniture conservation practice in Berkeley, California, from 1983 to the present.

**Colombe Harvey** completed her bachelor's degree in history of art and archaeology at Université Laval, Quebec City, in 1975. For five years, she was involved in the restoration of ceramics and glass for the archaeological service of Quebec's Department of Cultural Affairs, then set up her own team of conservators. Since 1986, she has carried out sculpture conservation at the CCQ. She was senior conservator on the Ursuline Chapel project.

**Lynne Dakin Hastings** received her B.A. from Emory University, with additional training in decorative arts and cultural resource management from the Henry DuPont Winterthur Museum, Smithsonian Institution, Museum of Early Southern Decorative Arts, Colonial Williamsburg, and the National Park Service. An Albright-Wirth and Attingham Fellow, Hastings has been the curator and chief of Museum Services at Hampton since 1981. She also serves as a consultant to several area museums, as well as other National Park Service sites, and conducts study tours for the Smithsonian and National Trust. Hastings has published on the subjects related to Hampton, architectural and social history, American decorative arts, and museum collections management.

**R. Bruce Hoadley** holds a B.S. degree in forestry from the University of Connecticut, and Master of Forestry and Doctor of Forestry degrees in wood technology from Yale University. He is a senior technical advisor to the Architectural Woodwork Institute and is a professor in Wood Science and Technology at the University of Massachusetts at Amherst, with his principal focus in the areas of anatomy and fundamental properties of wood. Bruce Hoadley is the author of two books, *Understanding Wood* (1980) and *Identifying Wood* (1990).

**F. Carey Howlett** is senior conservator and conservator of furniture at the Colonial Williamsburg Foundation Williamsburg, Virginia. He is a graduate of Davidson College and of the Smithsonian Institution's Furniture Conservation Training Program. He has served as chair of the Wooden Artifacts Group of the American Institute for Conservation and on the board of directors of the Virginia Conservation Association. His research, lectures, and articles have addressed such topics as the study and conservation of Thomas Jefferson's 1786 plaster model for the state capitol of Virginia, the identification of plant materials used in historic upholstered furniture, the development of techniques to reduce warpage in wooden objects, and the conservation of American painted furniture.

**Anna C. Hulbert** obtained her degree in the history of art in 1966 from the Courtauld Institute, University of London, where she subsequently studied the conservation of easel paintings under S. Rees-Jones Sr. Following work for Pauline Plummer and for E. Clive Rouse, and further study at the Fortezza da Basso, Florence, and the Bayerisches Landesamt für Denkmalpflege, Munich, she established her own conservation practice, specializing in English medieval ecclesiastical polychromy and wall paintings.

**Valerie Reich Hunt** received her B.A. in art history from Vassar College in 1980. She studied chemistry at the State University of New York at Stony Brook and, as technical collaborator, studied analytical analysis at Brookhaven National Laboratory. In 1986, she received her M.A. and Certificate in Advanced Study in Conservation from the Art Conservation Department, State University College at Buffalo. Since 1984, she has developed a speciality in the conservation of painted and composite folk art, as the objects conservator at Shelburne Museum, Shelburne, Vermont.

**Laurence Libin** is the Frederick P. Rose Curator in Charge, in the Department of Musical Instruments at the Metropolitan Museum of Art in New York.

**Michele D. Marincola** is an associate conservator for The Cloisters, the Sherman Fairchild Center for Objects Conservation, the Metropolitan Museum of Art, New York. From 1990 until 1995, she was an assistant conservator at the museum. She received her B.A. from Brown University in 1981, and her M.A. and Certificate of Conservation from the Institute of Fine Arts, New York University, in 1990. Her advanced training in the investigation and conservation of polychrome sculpture took place at the Bayerisches Nationalmuseum, Munich; at a private conservation studio in Florence, Italy; and at the Metropolitan Museum of Art.

**James S. Martin** received his M.S. from the Winterthur/University of Delaware Program in Art Conservation in 1989. He is director of Analytical Services and Research and associate conservator of paintings at the Williamstown Art Conservation Center. He also lectures on scientific analysis of works of art at Williams College and the Conservation Analytical Laboratory. His research interests focus on analysis of painted and coated surfaces. Among his publications are an analytical study of fourteen paintings by Grant Wood, the microscopic analysis of painted silk textiles, the role of scientific analysis in the conservation and interpretation of works of art, and the Center's *Analytical Services Bulletin*.

**Mary McGinn** received her M.S. degree in art conservation in 1994 from the Winterthur/University of Delaware Program in Art Conservation. She is currently working under contract at the Pennsylvania Academy of Fine Arts.

**Marion F. Mecklenburg** received his B.S., M.S., and Ph.D. from the University of Maryland. Prior to joining the Smithsonian Institution in 1987, he worked as a paintings conservator for twenty years. Currently, he is a research scientist investigating the effects of the environment on the mechanical properties of cultural materials.

**Stefan Michalski** graduated in 1972 with an Honors B.Sc. in Physics from Queen's University, Kingston, Ontario. From 1977 to 1979, he trained as an artifacts conservator in the Master of Art Conservation Program of Queen's University. He joined the Canadian Conservation Institute in 1979 and is currently a senior conservation scientist in the Environment and Deterioration Research Services Section. He is a consultant to Canadian museums on architectural, mechanical,

and display case aspects of environmental control. He is currently carrying out research on response of paintings to relative humidity, solvents, and temperature.

**Elizabeth Moffatt** received her Bachelor of Science degree from Memorial University of Newfoundland in 1975 and her Master of Science degree in organic chemistry from the University of Ottawa in 1977. She has worked in the Analytical Research Services Division of the CCI since 1978 and is currently a senior conservation scientist.

**Robert Mussey Jr.** is a partner in the private furniture and upholstery conservation laboratory of Robert Mussey Associates. He was the founder and, for eight years, chief furniture conservator of the Furniture Conservation Laboratory, the Society for the Preservation of New England Antiquities, Boston, Massachusetts. He has authored numerous articles on the history of furniture finishes and on Boston bombé furniture of the eighteenth century. He is currently working on major studies and publications on Boston cabinetmakers John and Thomas Seymour and on the furniture of the Caribbean and West Indies.

**Richard Newman** has been research scientist at the Museum of Fine Arts, Boston, since 1986. Prior to that, he served as sculpture/conservation scientist and assistant conservator of objects at the Harvard University Art Museums. Among his publications are several on identification of materials used in stone sculpture of the Indian subcontinent and chapters in two major books on the painting materials and techniques of Diego Velazquez. Among his current projects focused on paintings are an analytical study of paint binders and varnishes used on ancient Egyptian artifacts and a collaborative investigation of the binding media of the twentieth-century American painter Arthur Dove.

**Nancy Odegaard** has been the conservator for the Arizona State Museum since 1983. She received her B.A. with Distinction Honors from the University of Redlands, her M.A. from the George Washington University, specializing in anthropological conservation, and a certificate of conservation training from the Smithsonian Institution. In 1977, she was awarded the Ph.D. in Applied Science from the University of Canberra, specializing in cultural heritage conservation studies. She is a member of the faculty at the University of Arizona, where she directs interns and teaches. She has also participated in conservation training initiatives in China, Central America, and the United States, and is the coauthor of *A Guide to Handling Anthropological Museum Collections and Training for Collections Care and Maintenance: A Suggested Curriculum, Volume 1*.

**Rick Parker** is currently the senior conservator and owner of Parker Restoration and Conservation Services in Gentry, Arkansas. He is also the senior conservator of American Conservation Consortium's Midwest Conservation Laboratory. Parker is a professional associate of the American Institute for Conservation of Historic and Artistic Works and served as the chairman for the AIC's Wooden Artifacts Group during 1991 and 1992. He has been a faculty member of the Smithsonian Institution's Furniture Conservation Training Program and holds a B.A. degree from John Brown University.

**Claude Payer** completed his master's degree in art conservation in 1982 at Queen's University, Kingston, Ontario. He also studied art history at Université Laval, Quebec City, and trained for two years in the restoration of polychrome sculpture at the Institut Royal du Patrimoine Artistique in Brussels. Since 1986, he has headed the sculpture lab at the Centre de conservation du Québec (CCQ). He was in charge of the Ursuline Chapel project.

**Hans Portsteffen** worked in several conservation workshops for five years, then studied conservation at the Kunsthochschule Stuttgart, Institut für Technologie der Malerei and received his diploma in 1986. Until June 1994, he had his own workshop in Munich, specializing in sculpture conservation and doing on-site conservation, as well as studio work. Presently, he is teaching at the Fachhochschule Köln, Fachbereich Restaurierung von Kunst-und Kulturgut.

**Nancie C. Ravenel** received her Master of Science degree in 1992 from the Winterthur/University of Delaware Program in Art Conservation. She was a contract conservator in the Frame Conservation Department at the National Gallery of Art, Washington, D.C., from 1993 until 1996.

**Stephen L. Ray** received his Bachelor of Fine Arts degree from Virginia Commonwealth University in 1972. He then enrolled as a special graduate student in the preconservation program at Virginia Commonwealth University. After apprenticing with a conservator who specialized in paintings and polychromed wood sculpture, he worked as a contract conservator specializing in gilded wood. He joined the staff of the Department of Conservation at the Colonial Williamsburg Foundation in 1986 and assisted with the establishment of a Historic Area Conservation Technician program. Until his death in 1997, he was the conservator of objects at Colonial Williamsburg.

**Julie A. Reilly** received her B.A. from Towson State University, Towson, Maryland, in 1979, and her M.A. in anthropology from the George Washington University. She later worked as an archaeological conservator for the American University in Washington, D.C. In 1986, she joined the Colonial Williamsburg Foundation as conservator of objects and also was responsible for development and implementation of the Historic Area Conservation Technician Program. From 1991 to 1995, she was conservator of objects at the Winterthur Museum and Gardens, where she also served as associate adjunct professor in the Winterthur/University of Delaware Program in Art Conservation. She is now director of the Gerald Ford Conservation Center in Omaha, Nebraska.

**Frances Gruber Safford** is associate curator in the Department of American Decorative Arts at the Metropolitan Museum of Art in New York. American furniture of the seventeenth and early eighteenth centuries has long been a major focus of her research.

**Wendy Hartman Samet** is the former paintings conservator at the Winterthur Museum, where she worked from 1988 to 1997 and taught at the Winterthur/University of Delaware Program in Art Conservation. She received her B.F.A. in painting from the Kansas City Art Institute, was trained at the University of Pittsburgh in art history and chemistry, and received her M.S. from the Winterthur/University of Delaware program. She studied at the Barnes Foundation, where she was later paintings conservator, and completed a Mellon Postgraduate Fellowship at the Walters Art Gallery. She was the conservator in charge of the conservation of Whistler's Peacock Room at the Freer Gallery of Art (1988–92). She is a fellow of the American Institute for Conservation of Historic and Artistic Works, is a past chairperson of the Painting Specialty Group, and serves on the editorial board for the Paintings Catalogue, where she is compiler for the "Varnish" chapter.

**Elizabeth Howard Schmidt** received her B.A. and M.A. in art history from Virginia Commonwealth University. Her thesis, "Giovanni di Ser Giovanni: His Oeuvre Reconsidered," discusses the works attributed to this quattrocento Italian furniture painter. She held the position of curator of collections at Agecroft Hall for ten years until she retired in January 1994. During her tenure there, she conducted research each year in England and Scotland on the decorative arts of the sixteenth and seventeenth centuries.

**Myriam Serck-Dewaide** received her degree in the history of art and archaeology from the University of Louvain. She was a pupil of Agnes Ballestrem and is now head of the sculpture conservation workshop of the Institut Royal du Patrimoine Artistique in Brussels. She also teaches at the Institut de Formation des Restaurateurs d'Oeuvres d'Art in Paris and at the Ecole des arts visuels de la Cambre in Brussels. She is the author of more than fifty articles on polychrome sculpture.

**Chris A. Shelton** graduated from the University of Delaware with a B.A. in the Technology of Artistic and Historic Objects and received his M.S. from the Winterthur/University of Delaware Program in Art Conservation. He interned in furniture conservation at the Colonial Williamsburg Foundation and, since 1992, has worked as the associate furniture conservator for the Bayou Bend collection of the Museum of Fine Arts, Houston.

**Peter L. Sixbey** is conservator and museums coordinator for the Arkansas Department of Parks and Tourism in Little Rock. He worked with Robert F. McGiffin and supervised the decorative arts and wooden objects conservation labs at the Kansas Museum of History in Topeka. He has worked at the Kansas City Museum and the Nelson-Atkins Museum in Kansas City, Missouri; at Western Paintings Conservation in Denver; and at the Wyoming State Museum in Cheyenne.

**Jack Soutanian** received his M.A. in the history of art and Certificate in Conservation from the Institute of Fine Arts, New York University, in 1977. The same year, he joined the staff of the Isabella Stewart Gardner Museum, Boston, as a senior conservator of objects and, from 1980 until 1986, served as the museum's chief conservator. Since 1987, he has been both a conservator at the Metropolitan Museum of Art and The Cloisters, New York, responsible for the conservation of European sculpture, and an adjunct professor of conservation at the Conservation Center, Institute of Fine Arts, New York University.

**Luiz A. C. Souza** completed his B.S. (1986) and M.Sc. (1991) in chemistry at the Federal University of Minas Gerais, Brazil. The research for his M.Sc. was performed at the Institut Royal du Patrimoine Artistique, Brussels, in 1987–88. Since 1989, he has been teaching and conducting research at the Center for Conservation and Restoration of Cultural Movable Properties (CECOR) of the Federal University of Minas Gerais. During 1992–93, Luiz undertook a two-year research fellowship at the Scientific Program of the Getty Conservation Institute, working with materials and techniques of Baroque polychromed sculptures in Brazil.

**Jonathan Thornton** attended graduate school in art conservation at Cooperstown, New York, after an earlier career as an independent craftsman. He completed an internship at the Victoria and Albert Museum in London and began teaching at Cooperstown in 1980. He continues to teach object conservation in the same graduate program, which has since moved to Buffalo State College in Buffalo, New York. He is presently a full professor.

**Andrew Todd** is a sculpture conservator based in Vancouver, British Columbia, Canada. He has been in private practice since 1982, first in Calgary and for the past ten years in Vancouver. During this time, treatment projects have been conducted within major institutions, including, most recently, the Sculpture Conservation Laboratory of the National Gallery of Canada. Prior to establishing this practice, he spent seven years with Canada's two major conservation facilities: Parks Canada and the Canadian Conservation Institute. His Vancouver practice in conservation has given him the opportunity to provide treatment for a diverse variety of historical and artistic objects, both in the region and in many locations around the world.

**Charles S. Tumosa** received his Ph.D. in chemistry from Virginia Polytechnic Institute and State University. From 1972 to 1989, he was head of the Criminalistics Laboratory in Philadelphia. In 1989, he joined the Conservation Analytical Laboratory of the Smithsonian Institution, first as head of Analytical Services and then as a senior research chemist. His areas of interest are the analysis of trace materials and the effects of environment on material properties of cultural materials.

**Lori van Handel** received her B.A. in Art History from the University of Washington, Seattle. She specialized in conservation of painted objects at Queen's University, Kingston Ontario, where she received her master's degree in art conservation. She has had internships in the conservation of painted objects at the Detroit Institute of Arts, the M. H. de Young Memorial Museum in San Francisco, and the Shelburne Museum in Vermont. Prior to joining the Williamstown Art Conservation Center as assistant conservator and director of field services, she was an Andrew W. Mellon Fellow in the Department of Objects Conservation and Scientific Research at the Museum of Fine Arts, Boston.

**Marianne Webb** has been the decorative arts conservator at the Royal Ontario Museum since 1982. She specializes in organic and mixed materials, with a particular interest in oriental lacquer. After completing her B.A. in fine art at the University of Toronto in 1976, she worked several years at the Art Gallery of Ontario. She graduated from the Art Conservation Programme at Sir Sandford Fleming College in 1982. She has studied various aspects of lacquer and japanning for more than ten years and has lectured widely on the subject both in her home base of Toronto and around the world. She is presently the coordinator of the ICOM-Committee for Conservation Interim Working Group on Lacquer, now called the Working Group on Lacquer and Furniture.

**Elizabeth White** studied modern history at Oxford University before joining the curatorial staff of the Victoria and Albert Museum, London. She worked initially in the Department of Textiles and Dress, and later in the Furniture and Woodwork Department, specializing in the seventeenth- and



eighteenth-century British collections. Since 1984, she has taught history of applied art at the University of Bristol. In 1990, she published *The Pictorial Dictionary of British Eighteenth Century Furniture Designs*, and has assisted at the American Museum in Britain in the study of the influence of British designers on American furniture.

**Marc A. Williams** is president of American Conservation Consortium, Ltd., of Fremont, New Hampshire, which provides preservation consultation and treatment of furniture, wooden objects, and horse-drawn vehicles. He received his Masters of Science in furniture conservation, with a minor in painted wood, from the Winterthur/University of Delaware Program in Art Conservation, and served an internship at the Museum of Fine Arts, Boston. He is the former chief wooden objects conservator at the Smithsonian Institution and served as the founding director of the Smithsonian's Furniture Conservation Training Program. He is a fellow of the American Institute for Conservation.

**Richard C. Wolbers** is an associate professor in the Art Conservation Department, in the Winterthur/University of Delaware Program in Art Conservation. He received his M.S. degree in art conservation from the University of Delaware in 1984.

**James Yorke** is assistant curator in the Furniture and Woodwork Collections at the Victoria and Albert Museum, London. He is responsible for the furniture archives and library. He has published two books, *English Furniture* (Bison Books 1990) and *Portugal's Gift of Silver to the Duke of Wellington* (Academic Press 1992), and a number of articles on furniture and interiors. He was elected a fellow of the Society of Antiquaries in March 1997.

# Illustration Credits

## Part One

**Opening page:** Courtesy of the Museum of Fine Arts, Boston.

**Newman** *Tempera and Other Nondrying-Oil Media*

Figures 4, 9: Courtesy of the Museum of Fine Arts, Boston.

## Part Two

**Opening page:** Courtesy of the Institut Royal du Patrimoine Artistique, Brussels.

**Serck-Dewaide** *Support and Polychromy of Altarpieces*

Figures 1, 3–7, 8a–b: Courtesy of the Institut Royal du Patrimoine Artistique, Brussels.

**Ravenel** *Painted Italian Picture Frames*

Figure 1a–b: Courtesy of the Samuel H. Kress Foundation Collection, National Gallery of Art.

Figures 3, 5, 6, 8: Courtesy of the Samuel H. Kress Foundation Collection, National Gallery of Art. Photographs by Philip Charles.

**Yorke** *Royal Painted Furniture in King Charles I's England*

Figures 1, 3–5: Courtesy of the Board of Trustees of the Victoria and Albert Museum, London.

Figures 2, 6: Courtesy of the Public Record Office, London.

**White** *Perished Perches*

Figures 1–6: Reproduced courtesy of the Antique Collectors' Club, England.

**Buck** *Shaker Painted Furniture*

Figures 1, 3: Courtesy of Hancock Shaker Village, Pittsfield, Massachusetts. Photographs by Paul Rocheleau.

## Part Three

**Opening page:** All rights reserved, The Metropolitan Museum of Art, Gift of Mrs. J. Insley Blair, 1948. (48.158.11)

**Portsteffen** *Form and Polychromy*

Figure 1: Photograph courtesy of Bayerisches Landesamt für Denkmalpflege, Munich. Figures 2, 3, 5: Photographs by the author. Figure 4: Photograph courtesy of A. Bunz, Munich. Figure 6: Drawing by C. Blänzendorf. Figure 7: Drawing by the author. Figure 8: Photograph courtesy of H. Huber, Stuttgart.

**Gold** *Reconstruction and Analysis of Bismuth Painting*

Figure 1: Reproduced courtesy of Germanisches Nationalmuseum, Nürnberg. Figures 2, 3: Reproduced courtesy of Bayerisches Nationalmuseum, Munich.

**Libin** *Painted Harpsichords*

Figures 1, 2, 4: Reproduced courtesy of The Metropolitan Museum of Art, New York. Figures 3, 6, 7: Photographs courtesy of Sheridan Germann.

**Safford** *Floral Painting on Early Eighteenth-Century American Furniture*

Figures 1–5, 7: All rights reserved, The Metropolitan Museum of Art. Figures 6, 8: Drawings by Edward Di Farnecio.

**Shelton** *Short Primer on White-Painted Furnishings*

Figures 1, 2: Courtesy of Winterthur Museum. Figure 3: Courtesy of The Museum of Fine Arts, Houston; The Bayou Bend Collection, Museum purchase with funds provided by the Theta Charity Antiques Show.

**Mussey** *Verte Antique Decoration on American Furniture*

Figure 2: Anonymous collection. Photo by the author. Figure 3: Courtesy of Randall Scrimshar. Photo by David Bohl.

**Odegaard** *Investigation of the Nature of Paint on Wood Objects*

Figures 3 and 4: Courtesy of Arizona State Museum, The University of Arizona.

**Harpainter and Augerson** *Painted Furniture and Wooden Decorative Arts*

Figures 1, 3, 5: Courtesy of the Oakland Museum of California, Gift of the Concours d'Antiques, The Art Guild. Photos by Harrington and Olson. Figure 2: Courtesy of the Oakland Museum of California, Gift of Mrs. Margaret R. Kleinhans. Photo by M. Lee Fatheree. Figures 4, 6: Courtesy of the Oakland Museum of California, The Art Guild. Photo by M. Lee Fatheree.

**Part Four**

**Opening page:** Photo by Michel Elie and Jacques Beardsell, Centre de conservation du Québec, May 1993.

**Marincola and Soutanian** *Monochromy, Polychromy, and Authenticity*

Figures 1–5: Courtesy of The Metropolitan Museum of Art, The Cloisters Collection, 1975.

**Hulbert** *Conservation of the Fourteenth-Century Ceiling at St. Helen's Church*

Figures 1, 3–6, 8: Reproduced by kind permission of Anthony Burrett and of the Rector and Churchwardens of St. Helen's Church, Abingdon. Photos by Anthony Burrett. Figure 2: Adapted from a Herbert Read working drawing by kind permission of Richard Stanley. Figure 7: Reduced from tracings by the author with kind permission of the Rector and Churchwardens of St. Helen's Church, Abingdon.

**Payer et al.** *Interior Decor of the Ursuline Chapel*

Figure 2: Photo by Michel Elie, Centre de conservation du Québec (CCQ), May 1993. Figure 3: Photo by Michel Elie and Jacques Beardsell, CCQ, February 1994. Figure 4: Photo by Michel Elie, CCQ, September 1991. Figure 5: Private collection, Winnipeg. Figure 7: Photo by Michel Elie, CCQ, January 1993. Figures 8–9: Photo by Michel Elie and Jacques Beardsell, CCQ, June 1993.

**Schmidt** *Painted Tester Bedstead at Agecroft Hall*

Figures 1–3, 5: Courtesy of the Agecroft Association. Figure 4: Courtesy of Victory Chinnery. Figure 6: Courtesy of Wiltshire County Council Library and Museum Service; and Victory Chinnery.

**Gilmore** *Hunnewell Cottage*

Figure 1: Photograph courtesy of Jane Hunnewell. Figures 3–4: Photo by D. Bohl.

**Ferrell** *Importance of Conservation to Research*

Figures 1–2, 4–6: Photo by Lynton Gardiner. Figure 3: Photo by Carol Warner.

**Ray and Reilly** *Treatment of Painted Wooden Folk Art*

Figures 1–8: Courtesy of The Colonial Williamsburg Foundation.

**Parker and Sixbey** *Jeffrey: Horse of a Different Color*

Figures 1–3: Courtesy of Friends of the Carousel Archives.

#### **Part Five**

**Opening page:** Photograph by Andrew Todd.

**Samet** *Philosophy of Aesthetic Reintegration*

Figure 1: Courtesy of the Philadelphia Museum of Art, Conservation Department. Figures 2, 3: Courtesy of the Winterthur Museum.

**Hunt** *Conservation of Folk Art*

Figures 1–8: Courtesy of the Shelburne Museum, Shelburne, Vermont.

**Hastings and Bigelow** *Collaborations Past and Present*

Figure 1: Courtesy of Alex Jamison Photography, Arlington, Virginia. Figures 2–3: Courtesy of Hampton National Historic Site.

**Gordon** *Applied Aesthetics*

Figures 1, 3: Courtesy of New York State Office of Parks, Recreation and Historic Preservation, Bureau of Historic Sites. Figure 2: Courtesy of Greene County Historical Society, Vedder Memorial Library, Coxsackie, New York. Figure 7: Founders Society Purchase with funds from Mr. and Mrs. Richard A. Manoogian, Robert H. Tannahill Foundation Fund, Gibbs-Williams Fund, Dexter M. Ferry Jr. Fund, Merrill Fund. Photograph © The Detroit Institute of Arts.

#### **Part Six**

**Opening page:** Photomicrograph from Parker and Sixbey (Fig. 6) herein.

**Michalski et al.** *The Ultrasonic Mister*

Figure 1: Courtesy of the Canadian Conservation Institute. Photo by Carl Bigras. Figure 2: Courtesy of the Canadian Conservation Institute. Illustration by Carl Schlichting. Figure 3: Illustration by Lori van Handel. Figure 4: Courtesy of the Museum of Fine Arts, Boston. Photo by Susanne Gänsicke. Figure 5: Courtesy of the Philadelphia Museum of Art. Photo by Joe Mikuliak.

