

True scale when printed on 8-1/2" x 11" sheet.

<b>SEISMIC RETROFITTING PROJECT</b> The Earthen Architecture Initiative 	Building:	CATHEDRAL OF ICA Ica, Perú	Drafted By:	William Sarmiento	Date:	October 2011
	Sheet Title:	Structural Prospections IS-1, IW-1, and IW-2	Supervisor:	Arch. Mirna Soto	Scale:	As Noted
			Facilitator:	Universidad Católica Sedes Sapientiae	Sheet No.:	
			Edited and Translated By:	Jabdiel Zapata		<b>IC-P-1</b>



IW-2



IS - 1B  
(CENTER OF WALL)



IS - 1A and IS-1B



IW-1



IW-2 and IS-1

### IW-1

THIS OPENING IS LOCATED INSIDE THE CHURCH, BETWEEN THE FACADE WALL AND THE ADJACENT PILASTER. ONE CAN OBSERVE THE BRICK WALL AND THE "QUINCHA" PILASTER CONNECTION DETAILS. IT SHOWS THE HORIZONTAL WOOD ELEMENTS HAVE A MINIMUM EMBEDMENT OF 50 TO 70 mm INTO THE BRICK WALL. THIS IS TO ENSURE THE CONTINUITY OF THE GYPSUM FINISH COAT.

### IS-1 - IW-2

THIS OPENING (IS-1A) IS LOCATED ON THE FLOOR, BETWEEN THE LATERAL WALL AND THE BASE OF THE BELL TOWER, WHICH HAS A PILASTER ATTACHED TO IT. AFTER REMOVING THE FLOOR TILES, LOOSE AND DAMP SOIL WAS OBSERVED UNDERNEATH THEM. THE FOUNDATION OF THE LATERAL WALL OF THE CHURCH IS COMPOSED OF ANGLED STONES WITH A SAND AND LIME MORTAR. THIS FOUNDATION IS 0.43 m DEEP, AND IT RESTS ON COMPACTED SOIL.

THE BASE OF THE PILASTER HAS THE FOLLOWING COMPOSITION: A BRICK MASONRY AND LIME MORTAR BASE TO A DEPTH OF 0.30 m BELOW FINISH FLOOR LEVEL; AND A 1.00 m DEEP STONE MASONRY AND LIME AND SAND MORTAR FOUNDATION, OFFSET 0.15 m FROM THE FACE OF THE BRICK BASE.

THIS OPENING (IS-1B) IS AT THE WALL NEXT TO THE PREVIOUS FLOOR OPENING (IS-1A). IT IS LOCATED AT THE RIGHT SIDE OF THE ALTAR PIECE OF SANTA ROSA DE LIMA. THE LATERAL WALL IS CONSTRUCTED WITH STONE MASONRY AND A SAND AND LIME MORTAR, INTERSPERSED WITH COURSES OF BRICK, TO A HEIGHT EXCEEDING 3 m. TOWARDS THE CENTER THE SAME WALL, IN ANOTHER OPENING, STONE IS NOT FOUND - ONLY BRICK. AT A THIRD OPENING, LOCATED TO THE FAR LEFT, ADOBE WAS OBSERVED.

THIS OPENING (IW-2), ON THE LEFT SIDE OF THE ALTARPIECE OF SANTA ROSA DE LIMA, ALLOWS ONE TO OBSERVE THE STONE MASONRY "SOBRECIMIENTO" SET IN A SAND AND LIME MORTAR. IT HAS A HEIGHT OF 0.43 m. ABOVE THIS BASE THERE IS A 0.90 m HIGH BRICK MASONRY WALL WITH A SAND AND LIME MORTAR. FINALLY, ABOVE THIS IS THE ADOBE WALL.

AFTER SEEING ALL OF THESE OPENINGS, ONE CAN CONCLUDE THE FOLLOWING: THE BASE OF THE BELL TOWER HAS A SOLID STONE MASONRY FOUNDATION WITH A LIME AND SAND MORTAR. THIS FOUNDATION IS DEEPER AND HIGHER AS COMPARED TO THE REST OF THE FOUNDATIONS IN THE BUILDING. THE TRANSITION FROM STONE MASONRY TO ADOBE MASONRY IS ACCOMPLISHED BY PLACING A BRICK INTERFACE IN THE VERTICAL DIRECTION. THE INTERFACE IS ALSO IN THE HORIZONTAL DIRECTION, BETWEEN THE STONE "SOBRECIMIENTO," 0.90 m OF BRICK, AND THE ADOBE ABOVE. THIS CONSTRUCTION TECHNIQUE IS ALSO EXTANT IN A CHURCH LOCATED TWO BLOCKS AWAY FROM THE CATHEDRAL OF ICA AND CONSTRUCTED DURING THE SAME PERIOD.

True scale when printed on 8-1/2" x 11" sheet.

**SEISMIC RETROFITTING PROJECT**  
The Earthen Architecture Initiative



The Getty Conservation Institute



Building:  
**CATHEDRAL OF ICA**  
Ica, Perú

Sheet Title:  
**Structural Prospections**  
IS-1, IW-1, and IW-2

Drafted By:  
William Sarmiento

Supervisor:  
Arch. Mirna Soto

Facilitator:  
Universidad Católica Sedes Sapientiae

Edited and Translated By:  
Jabdiel Zapata

Date:  
October 2011

Scale:  
As Noted

Sheet No.:

**IC-P-2**

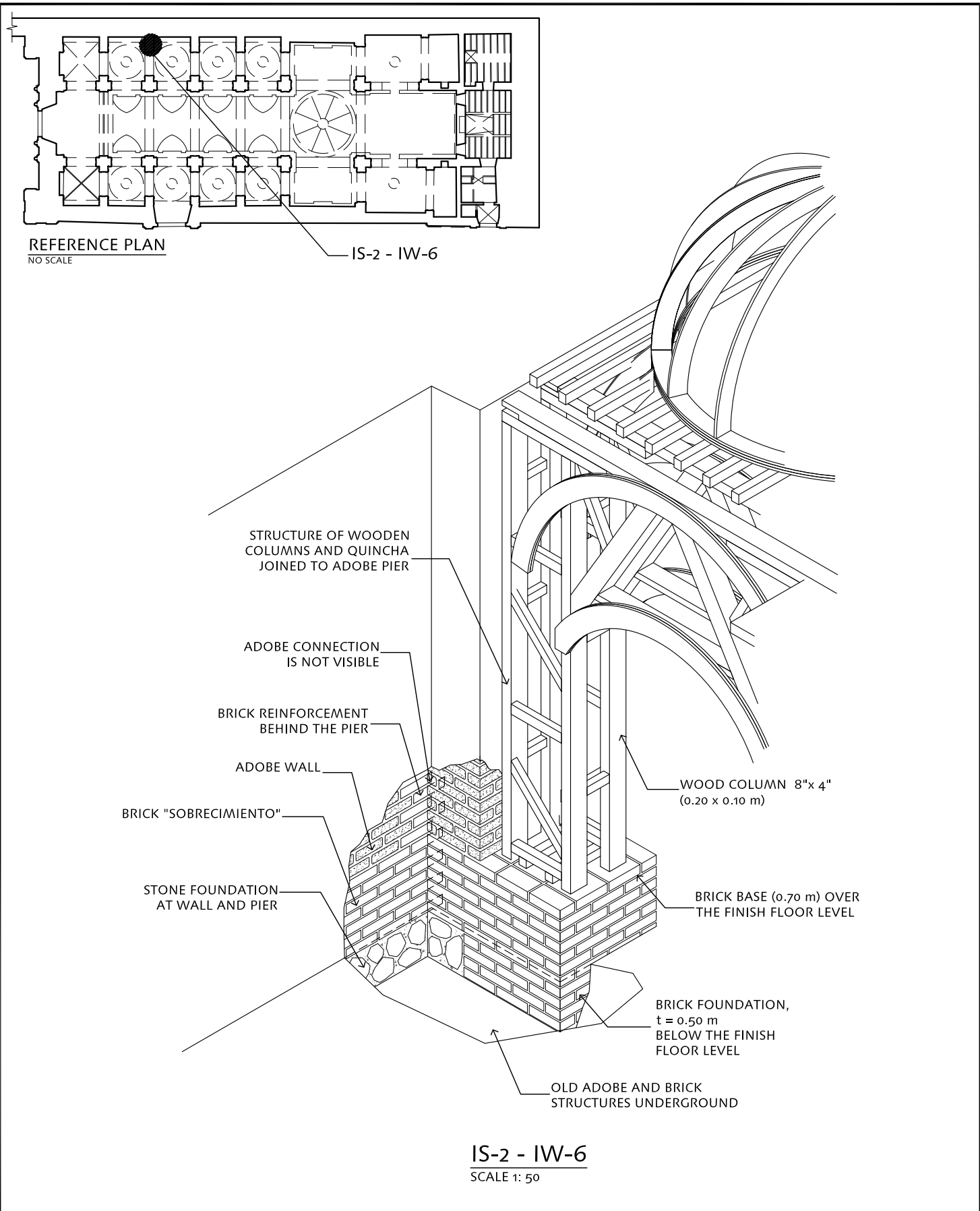

True scale when printed on 8-1/2" x 11" sheet.

**SEISMIC RETROFITTING PROJECT**  
The Earthen Architecture Initiative



The Getty Conservation Institute



Building:

**CATHEDRAL OF ICA**  
Ica, Perú

Sheet Title:

**Structural Prospections**  
IS-2 and IW-6

Drafted By:

William Sarmiento

Supervisor:

Arch. Mirna Soto

Facilitator:

Universidad Católica Sedes Sapientiae

Edited and Translated By:

Jabdiel Zapata

Date:

October 2011

Scale:

As Noted

Sheet No.:

**IC-P-3**



IS-2



IW-6

### IS-2

THIS OPENING LOCATED ON THE SOUTH LATERAL WALL OF THE CATHEDRAL ALLOWS US TO OBSERVE THE CHARACTERISTICS AND DIMENSIONS OF THE FOUNDATIONS. AFTER LIFTING THE FLOOR TILE AND REMOVING THE COMPACTED SOIL WE WERE ABLE TO SEE THE FOUNDATION, WHICH IS THE SAME WIDTH AS THE WALL ABOVE AND IS CONSTRUCTED WITH ANGULAR STONES AND A LIME MORTAR. THE ADJOINING PILASTER FOUNDATION IS CONSTRUCTED WITH FIRED BRICK BONDED WITH A LIME MORTAR. AS WE CONTINUED DIGGING, AT 0.48 m BELOW THE FINISH FLOOR, WE FOUND A HIGHLY COMPACTED LAYER COMPOSED OF LEVEL BRICKS AND SOIL. THE BRICKS WERE SO DETERIORATED BY HUMIDITY THAT WE WERE UNABLE TO MOVE OR TOUCH THEM WITH OUT BREAKING THEM. WE WERE ABLE TO REMOVE THE SOIL AND SOME OF THESE BRICKS AND FOUND ANOTHER BRICK WALL UNDERNEATH. APPARENTLY, AND AS IS COMMON IN THESE TYPES OF RELIGIOUS STRUCTURES, THIS SUBTERRANEAN BRICK CONSTRUCTION IS A TYPE OF CATACOMB, WHICH IS ALSO SEEN IN THE CLOISTER OF THE ADJACENT JESUIT COLLEGE WHICH IN THE PAST WAS PART OF THE SAME RELIGIOUS COMPLEX AS THE CATHEDRAL. WE WERE UNABLE TO CONTINUE DIGGING BECAUSE IT WOULD REQUIRE A LARGER STUDY OF AN ARCHAEOLOGICAL NATURE.

### IW-6

THIS OPENING IS ALSO LOCATED ON THE SOUTH LATERAL WALL OF THE CATHEDRAL, WITH THE PURPOSE OF ANALYZING THE "SOBRECIMIENTO." THE ADOBE WALL HAS A 0.60 m HIGH SOBRECIMIENTO CONSISTING OF SEVEN BRICK COURSES BONDED WITH A LIME MORTAR AND SET DIRECTLY OVER THE STONE FOUNDATION BELOW. THIS IS DIFFERENT FROM PROSPECTION IW-2 (NORTH LATERAL WALL), WHERE STONE WAS PRESENT IN THE SOBRECIMIENTO.

BETWEEN THE SOUTH LATERAL WALL AND EVERY WOOD-FRAMED PILASTER AT THE SIDE AISLE THERE IS AN ADOBE PIER OR BUTTRESS. THE WOOD-FRAMED PILASTER IS CONNECTED DIRECTLY TO THE ADOBE PIER, WHICH IN TURN IS CONNECTED TO THE LATERAL WALL. FINALLY, IT IS IMPORTANT TO NOTE THAT THE PORTION OF THE LATERAL WALL IN CONTACT WITH THE PIER IS BRICK. THE WALL IS PLASTERED WITH MUD AND HAS A GYPSUM FINISH COAT.

True scale when printed on 8-1/2" x 11" sheet.

**SEISMIC RETROFITTING PROJECT**  
The Earthen Architecture Initiative



The Getty Conservation Institute



Building:  
**CATHEDRAL OF ICA**  
Ica, Perú

Sheet Title:  
**Structural Prospections**  
IS-2 and IW-6

Drafted By:  
William Sarmiento

Supervisor:  
Arch. Mirna Soto

Facilitator:  
Universidad Católica Sedes Sapientiae

Edited and Translated By:  
Jabdiel Zapata

Date:  
October 2011

Scale:  
As Noted

Sheet No.:  
**IC-P-4**

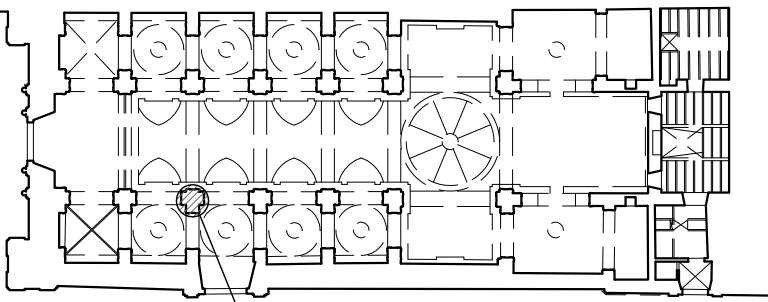

**REFERENCE PLAN**  
NO SCALE

IW-3

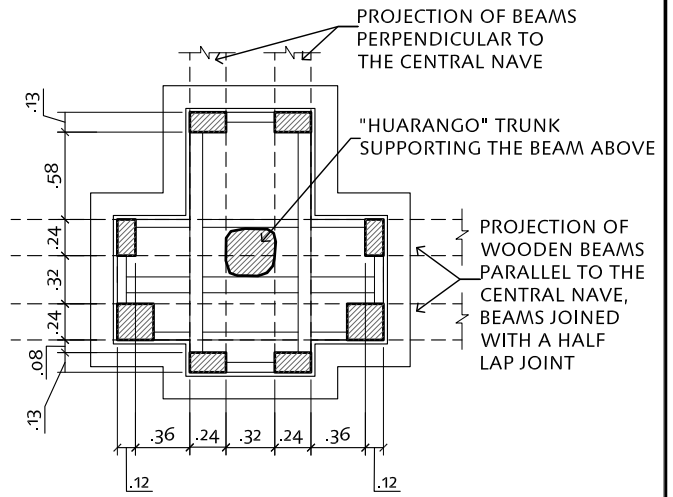

**FLOOR PLAN**

SCALE: 1: 50

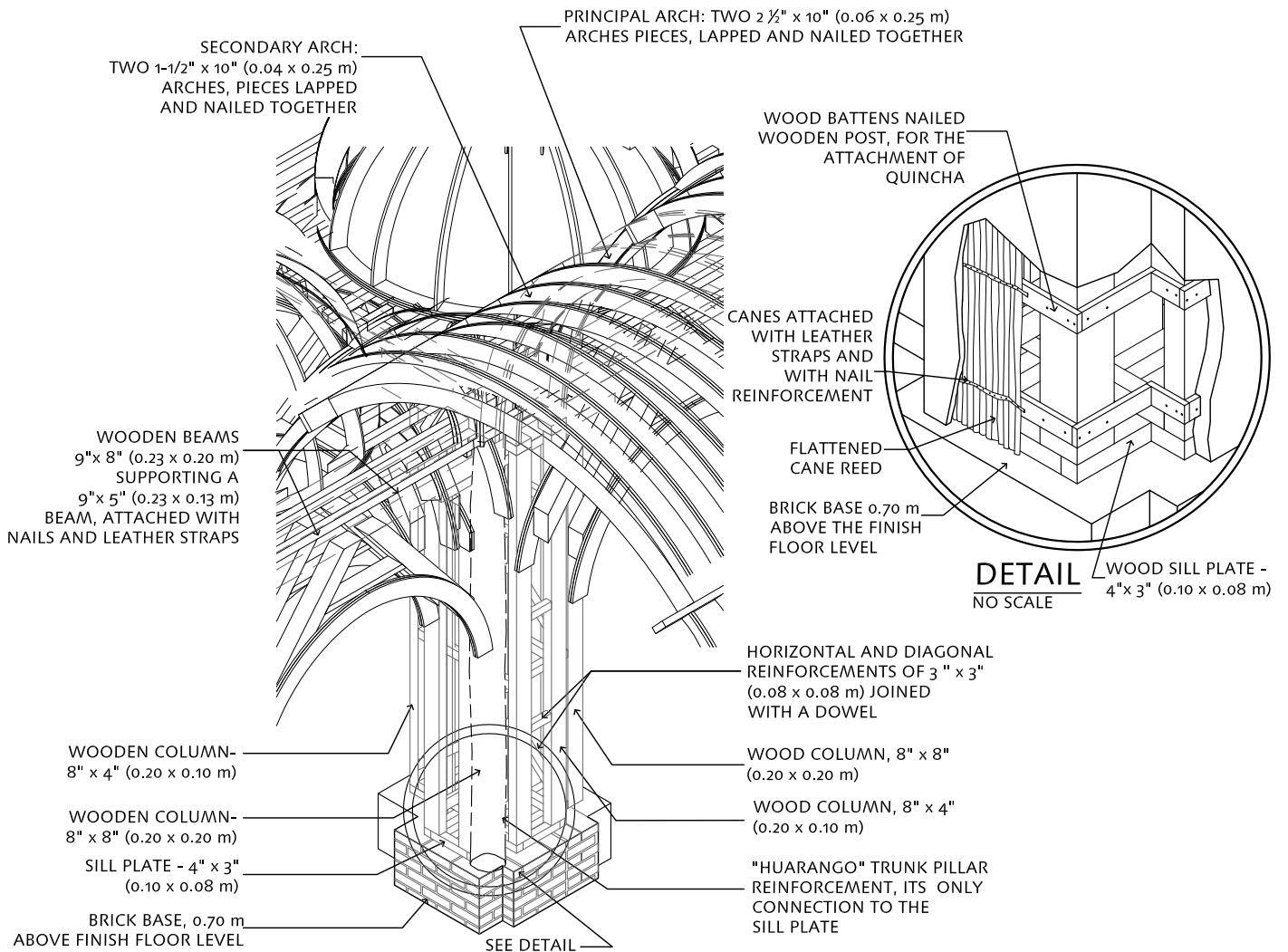

**IW-3**  
SCALE 1: 75

**DETAIL**  
NO SCALE

WOOD SILL PLATE - 4"x 3" (0.10 x 0.08 m)

True scale when printed on 8-1/2" x 11" sheet.

**SEISMIC RETROFITTING PROJECT**  
The Earthen Architecture Initiative



The Getty Conservation Institute



Building: **CATHEDRAL OF ICA**  
Ica, Perú

Sheet Title: **Structural Prospection**  
IW-3

Drafted By: **William Sarmiento**

Supervisor: **Arch. Mirna Soto**

Facilitator: **Universidad Católica Sedes Sapientiae**

Edited and Translated By: **Jabdiel Zapata**

Date: **October 2011**

Scale: **As Noted**

Sheet No.:

**IC-P-5**

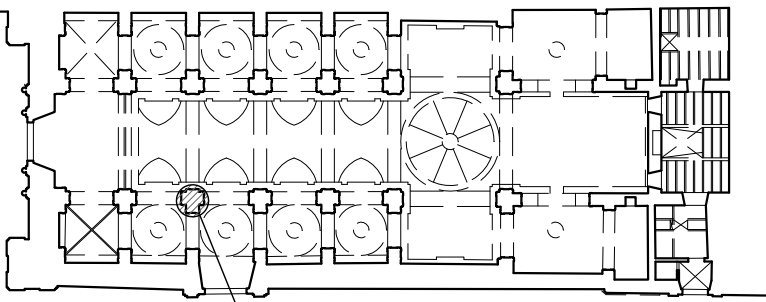

REFERENCE PLAN  
NO SCALE

IW-3

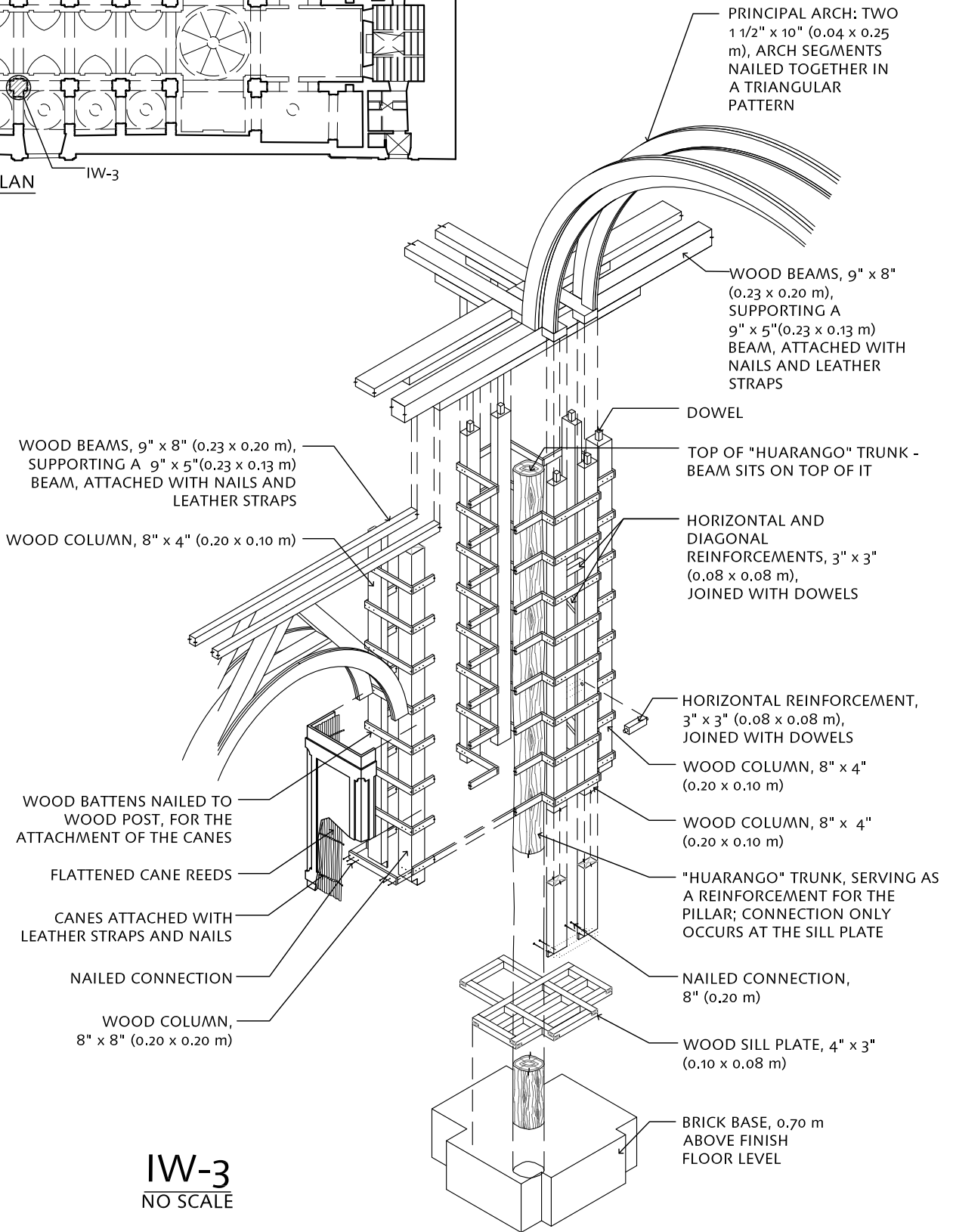

IW-3  
NO SCALE

True scale when printed on 8-1/2" x 11" sheet.

SEISMIC RETROFITTING PROJECT  
The Earthen Architecture Initiative



The Getty Conservation Institute



Building: CATHEDRAL OF ICA  
Ica, Perú

Sheet Title: Structural Prospection  
IW-3

Drafted By: William Sarmiento

Supervisor: Arch. Mirna Soto

Facilitator: Universidad Católica Sedes Sapientiae

Edited and Translated By: Jabdriel Zapata

Date: October 2011

Scale: As Noted

Sheet No.:

IC-P-5A



IW-3



IW-3

IW-3

THIS OPENING IS LOCATED AT ONE OF THE PILLARS OF THE CENTRAL NAVE. IT HAS A BRICK MASONRY BASE WITH A LIME AND SAND MORTAR. THIS BASE IS 0.70 m ABOVE THE FLOOR LEVEL. THE PILLAR IS COVERED WITH PLASTER MOLDINGS. UNDER THIS PLASTER LAYER ARE FLATTENED CANE REEDS ATTACHED WITH LEATHER STRAPS AND FORGED IRON NAILS TO THE WOODEN COLUMNS THAT FORM THE PILLAR. THE DIMENSIONS OF THE WOODEN COLUMNS ARE 8" x 8" (0.203 x 0.203 m) AND 8" x 4" (0.203 x 0.101 m) THESE WOODEN COLUMNS ARE EMBEDDED IN THE BRICK BASE AND JOINED AT THE BOTTOM BY A SILL PLATE WITH FORGED IRON NAILS. ALL OF THIS SILL PLATE IS COVERED WITH BRICKS LAID IN A LIME MORTAR. IN THE CENTER OF THE PILLAR THERE IS A "HUARANGO" TRUNK WORKING AS A SUPPORT FOR THE BEAM ABOVE.

True scale when printed on 8-1/2" x 11" sheet.

<b>SEISMIC RETROFITTING PROJECT</b> The Earthen Architecture Initiative 	Building: <b>CATHEDRAL OF ICA</b> Ica, Perú	Drafted By: William Sarmiento	Date: October 2011
	Sheet Title: <b>Structural Prospection</b> IW- 3	Supervisor: Arch. Mirna Soto	Scale: As Noted

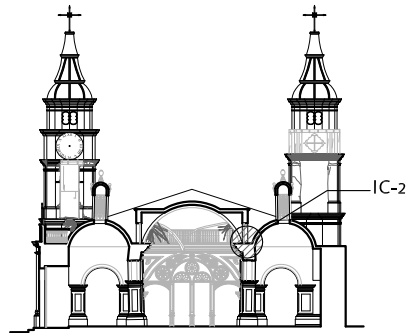

REFERENCE SECTION  
NO SCALE

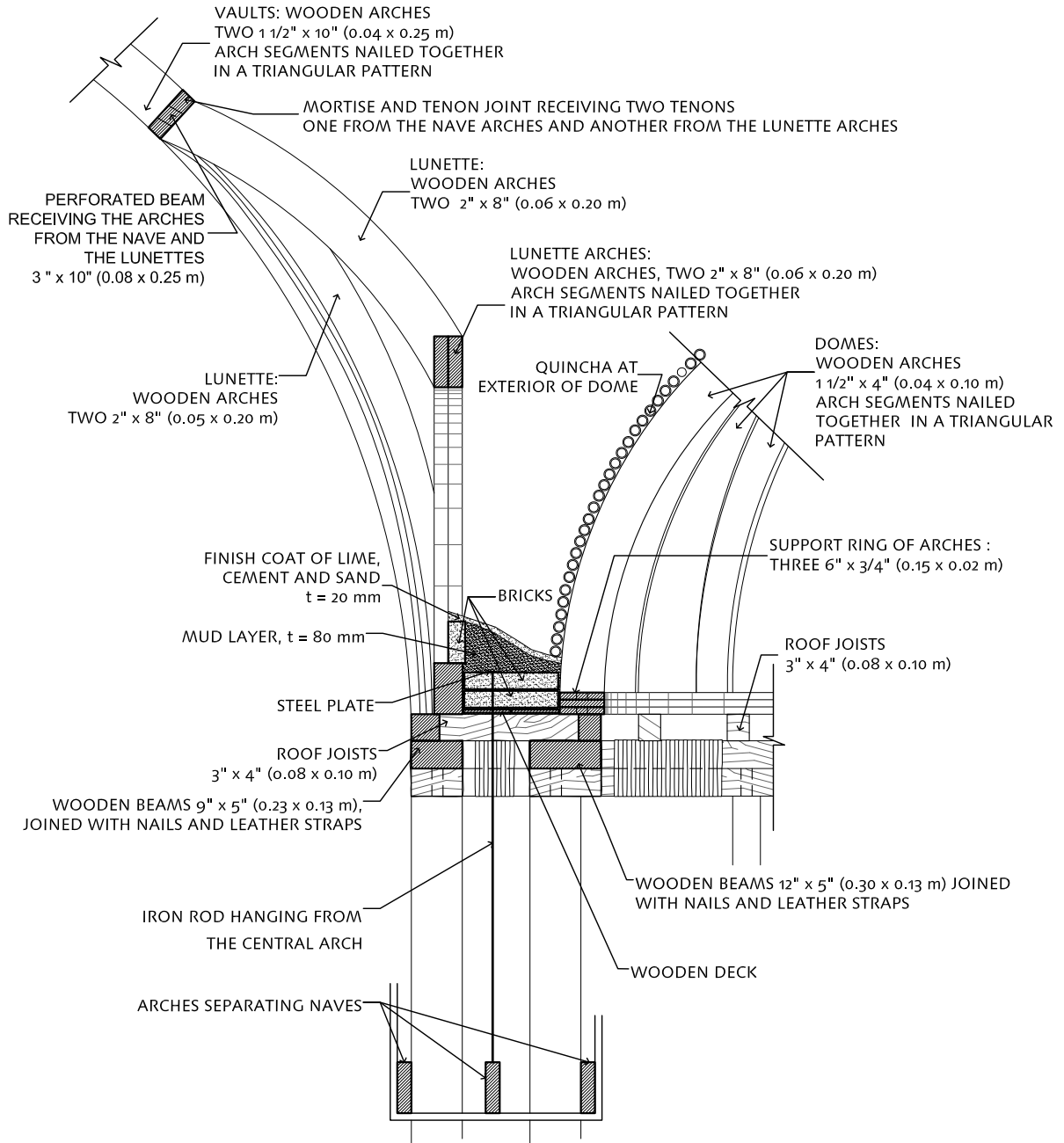

IC-2  
SCALE 1: 75

SEISMIC RETROFITTING PROJECT  
The Earthen Architecture Initiative



The Getty Conservation Institute



Building: CATHEDRAL OF ICA  
Ica, Perú

Sheet Title: Structural Prospection  
IC-2

Drafted By:  
William Sarmiento

Supervisor:  
Arch. Mirna Soto

Facilitator:  
Universidad Católica Sedes Sapientiae

Edited and Translated By:  
Jabdiel Zapata

Date:  
October 2011

Scale:  
As Noted

Sheet No.:

IC-P-7



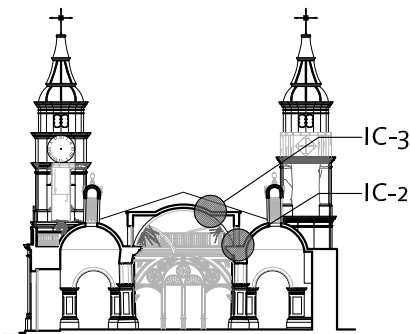

**REFERENCE SECTION**  
NO SCALE

**DETAIL IC-3**  
NO SCALE

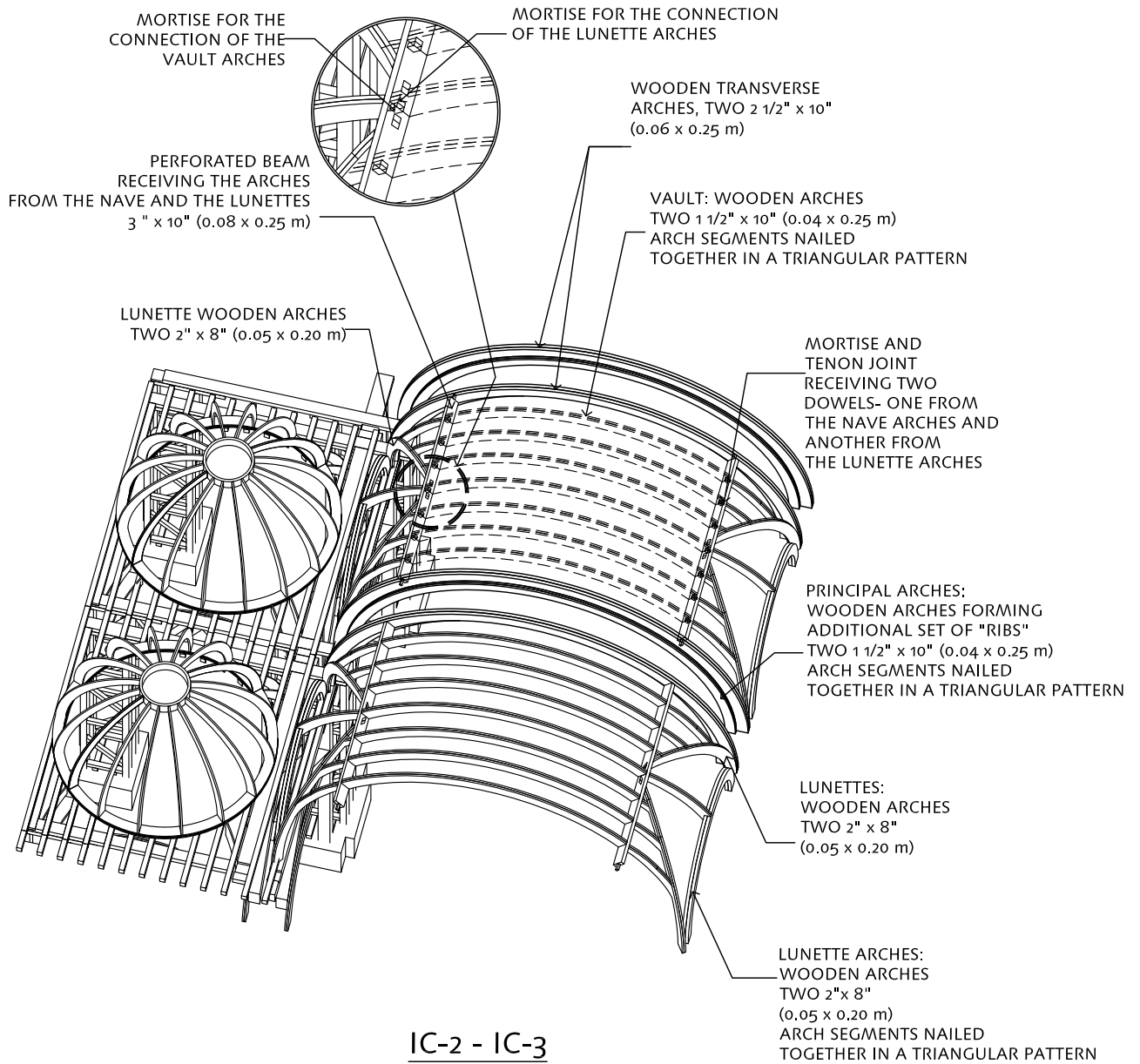

**IC-2 - IC-3**  
SCALE 1: 50

True scale when printed on 8-1/2" x 11" sheet.

**SEISMIC RETROFITTING PROJECT**  
The Earthen Architecture Initiative



The Getty Conservation Institute



Building: **CATHEDRAL OF ICA**  
Ica, Perú

Sheet Title: **Structural Prospections**  
IC-2 and IC-3

Drafted By: **William Sarmiento**

Supervisor: **Arch. Mirna Soto**

Facilitator: **Universidad Católica Sedes Sapientiae**

Edited and Translated By: **Jabdiel Zapata**

Date: **October 2011**

Scale: **As Noted**

Sheet No.:

**IC-P-8**



IC-3



IC-2

IC-2

THE MAIN ELEMENT OF THIS CONNECTION IS A BEAM (OR ARCADE PLATE) WHICH RUNS ALONG OF THE CENTRAL NAVE. THIS BEAM CONSISTS OF TWO WOOD ELEMENTS MEASURING APPROXIMATELY 9" x 5" (0.23 x 0.13 m) AND 12" X 5" (0.31 X 0.13 m). ABOVE THE BEAM ARE 3" x 4" (0.08 x 0.10 m) ROOF JOISTS COMING FROM THE SIDE AISLE. ON ONE SIDE OF THE JOISTS THERE IS A WOODEN RING WHICH SUPPORTS THE SMALL DOMES, AND ON THE OTHER SIDE THERE IS A WOODEN BEAM THAT SUPPORTS THE LUNETTE WINDOW. THE SPACE BETWEEN THE DOME AND WINDOW IS COVERED BY A WOOD DECK WHICH EXTENDS ACROSS THE WIDTH OF THE SIDE AISLE. COVERING THE TOP OF THE DECK ARE TWO ROWS OF BRICK BONDED WITH A CLAY MORTAR FOLLOWED BY A LAYER OF MUD. FINALLY THERE IS A LAYER OF LIME, SAND AND CEMENT MORTAR WHICH COVERS THE ENTIRE ROOF OF THE SIDE AISLE.

ABOVE THE LUNETTE SUPPORT BEAM IS THE WINDOW GLASS ITSELF. THE MUD, LIME AND SAND MORTAR AT THE ROOF IS RAISED AND SLOPED IN FRONT OF THE WINDOW SILL IN ORDER TO PREVENT RAIN WATER INFILTRATION.

THIS PROSPECTION ALSO REVEALED THE PRESENCE OF A SMALL METAL PLATE ON THE BRICK THAT SECURES THE IRON ROD THAT RUNS VERTICALLY THROUGH THE ARCH SEPARATING THE CENTRAL NAVE FROM THE SIDE AISLE. IT IS POSSIBLE THAT THIS ROD HELPS TO SUPPORT THE SOFFIT OF THE ARCH.

IC-3

THIS OPENING IS LOCATED AT THE TOP OF THE LUNETTE. THERE IS A WOODEN BEAM RUNNING ALONG THE NAVE WHICH RECEIVES THE TENONS FROM ALL THE NAVE ROOF ARCHES. THIS BEAM ALSO SERVES AS THE TOP CONNECTION POINT FOR THE TENONS OF THE LUNETTE ARCHES. THEREFORE, THIS BEAM HAS MANY MORTISE HOLES AND RECEIVES AT LEAST TWO TENONS; ONE COMING FROM OF THE CENTRAL PART OF THE NAVE AND THE OTHER FROM THE SIDE PART OF THE NAVE OR LUNETTE. HOWEVER, IN THE AREA CORRESPONDING TO THE APEX OF THE LUNETTE, FOUR TENONS CONVERGE CLOSE TO ONE OTHER; ONE FROM THE NAVE, TWO FROM THE CORNERS OR EDGES OF THE LUNETTE, AND A LAST ONE FROM THE CENTER OF THE LUNETTE. THEREFORE THIS HORIZONTAL BEAM PROVIDES CROSS BRACING BETWEEN THE ROOF ARCHES. CONSEQUENTLY, THESE BEAMS ARE STRUCTURALLY IMPORTANT AND MARKED THE BREAKING POINT BETWEEN THE COLLAPSED AND THE REMAINING PORTIONS OF THE VAULT FOLLOWING THE 2007 EARTHQUAKE.

True scale when printed on 8-1/2" x 11" sheet.

**SEISMIC RETROFITTING PROJECT**  
The Earthen Architecture Initiative



The Getty Conservation Institute



Building:

CATHEDRAL OF ICA  
Ica, Perú

Sheet Title:

Structural Prospections  
IC- 2 and IC- 3

Drafted By:

William Sarmiento

Supervisor:

Arch. Mirna Soto

Facilitator:

Universidad Católica Sedes Sapientiae

Edited and Translated By:

Jabdiel Zapata

Date:

October 2011

Scale:

As Noted

Sheet No.:

IC-P-9

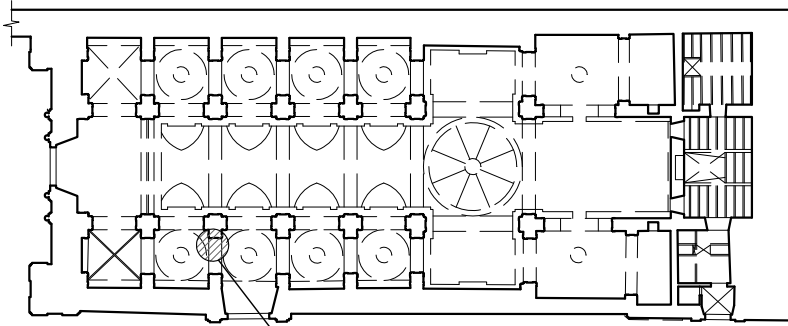

REFERENCE PLAN  
NO SCALE

IC-11

DOMES: WOODEN ARCHES  
1 1/2" x 4" (0.04 x 0.10 m)  
ARCH SEGMENTS NAILED TOGETHER  
IN A TRIANGULAR PATTERN

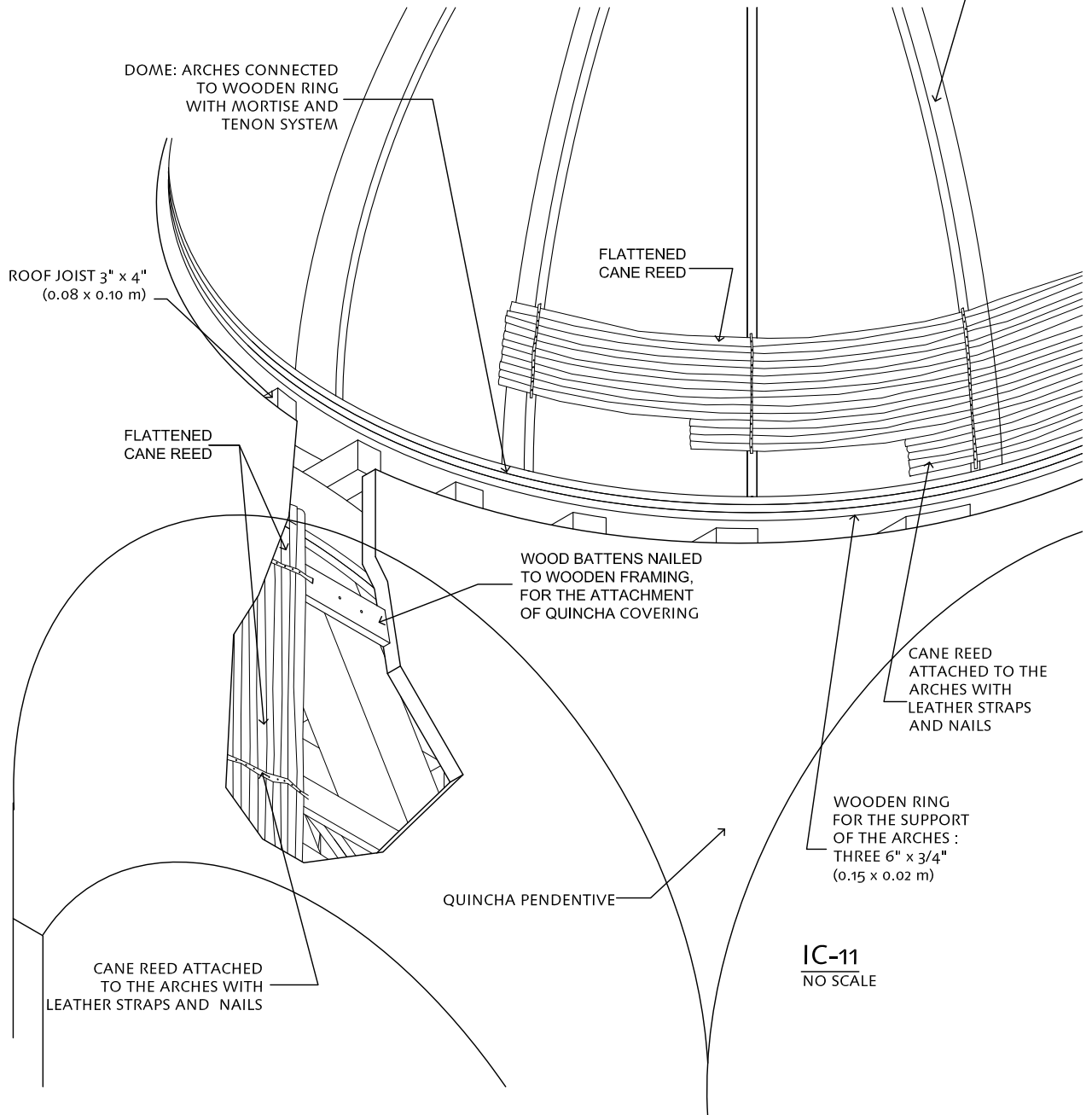

DOMES: ARCHES CONNECTED  
TO WOODEN RING  
WITH MORTISE AND  
TENON SYSTEM

ROOF JOIST 3" x 4"  
(0.08 x 0.10 m)

FLATTENED  
CANE REED

FLATTENED  
CANE REED

WOOD BATTENS NAILED  
TO WOODEN FRAMING,  
FOR THE ATTACHMENT  
OF QUINCHA COVERING

CANE REED  
ATTACHED TO THE  
ARCHES WITH  
LEATHER STRAPS  
AND NAILS

WOODEN RING  
FOR THE SUPPORT  
OF THE ARCHES :  
THREE 6" x 3/4"  
(0.15 x 0.02 m)

QUINCHA PENDENTIVE

CANE REED ATTACHED  
TO THE ARCHES WITH  
LEATHER STRAPS AND NAILS

IC-11  
NO SCALE

True scale when printed on 8-1/2" x 11" sheet.

SEISMIC RETROFITTING PROJECT  
The Earthen Architecture Initiative



The Getty Conservation Institute



Building: CATHEDRAL OF ICA  
Ica, Perú

Sheet Title: Structural Prospection  
IC-11

Drafted By:  
William Sarmiento

Supervisor:  
Arch. Mirna Soto

Facilitator:  
Universidad Católica Sedes Sapientiae

Edited and Translated By:  
Jabdiel Zapata

Date:  
October 2011

Scale:  
As Noted

Sheet No.:

IC-P-10

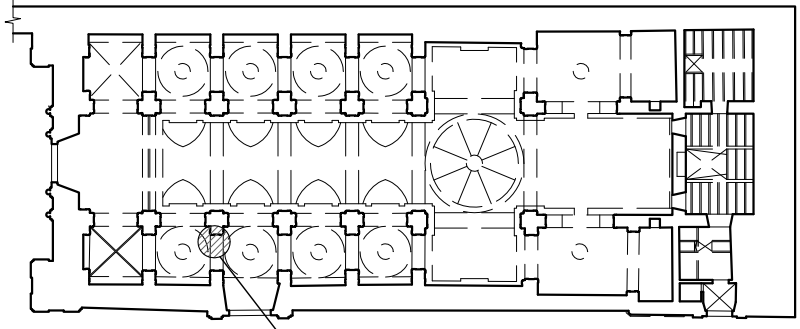

REFERENCE PLAN  
NO SCALE

IC-12

DOME: WOODEN ARCHES  
TWO 1 1/2" x 10" (0.04 x 0.25 m)  
ARCH SEGMENTS NAILED TOGETHER  
IN A TRIANGULAR PATTERN

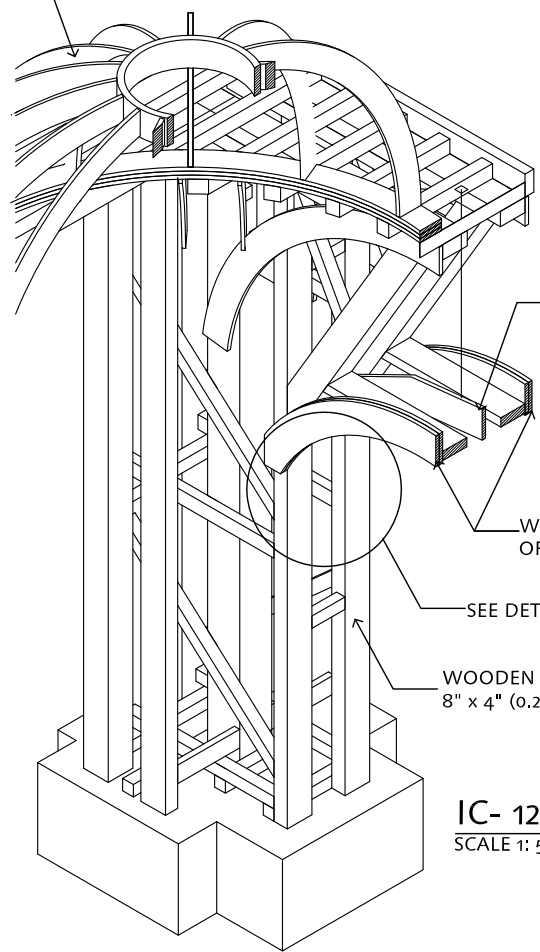

IRREGULAR CENTRAL ARCH,  
HUNG FROM DECK ABOVE  
AND SUPPORTING THE CANES  
THE INTRADOS (INNER CURVE)  
OF THE ARCH BELOW

IRREGULAR CENTRAL ARCH, HUNG  
FROM DECK ABOVE AND SUPPORTING  
THE CANES AT THE INTRADOS  
(INNER CURVE) OF THE ARCH BELOW

WOODEN ARCHES  
OF THE SIDE AISLE

SEE DETAIL

WOODEN POST  
8" x 4" (0.20 x 0.10 m)

IC- 12  
SCALE 1: 50

FLATTENED  
CANE REED

CANE REED  
ATTACHED  
THE ARCHES  
WITH LEATHER  
STRAPS AND NAILS

WOOD BATTENS  
NAILED TO THE  
WOODEN POST,  
FOR THE ATTACHMENT  
OF QUINCHA COVERING  
AT THE UNDERSIDE OF  
THE ARCH

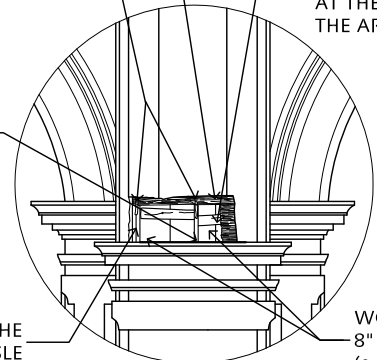

ARCHES OF THE  
SIDE AISLE

WOODEN POST  
8" x 4"  
(0.20 x 0.10 m)

DETAIL  
SCALE 1:50

True scale when printed on 8-1/2" x 11" sheet.

**SEISMIC RETROFITTING PROJECT**  
The Earthen Architecture Initiative



Building: **CATHEDRAL OF ICA**  
Ica, Perú

Sheet Title: **Structural Prospection**  
IC-12

Drafted By: William Sarmiento  
Supervisor: Arch. Mirna Soto  
Facilitator: Universidad Católica Sedes Sapientiae  
Edited and Translated By: Jabdiel Zapata

Date: October 2011  
Scale: As Noted  
Sheet No.: **IC-P-11**



IC-11



IC-12

IC-11

THIS OPENING IS LOCATED ABOVE ONE OF THE TRANSVERSE ARCHES, IN THE SIDE AISLES. UNDERNEATH THE GYPSUM FINISH COAT THERE ARE FLATTENED CANE REEDS NAILED OVER LEATHER STRAPS AND FIXED TO THE WOODEN STRUCTURE. THE INTERNAL STRUCTURAL SYSTEM, SIMILAR TO A POST-AND-LINTEL FRAMED OPENING, CONSISTS OF HORIZONTAL BEAMS WHICH ARE SUPPORTED BY THE QUINCHA PILLARS. OVER THESE BEAMS ARE JOISTS SUPPORTING THE WOODEN RING AT THE BASE OF THE SMALL DOMES. ON EITHER SIDE OF THE HORIZONTAL BEAMS (OR "LINTELS") ARE FIXED PIECES OF CURVED WOOD AT TWO LEVELS, ONE HIGHER AND ONE LOWER (SEE IC-12), THAT PRODUCE THE SHAPE OF THE TRANSVERSE ARCHES. THE SPACE BETWEEN THE TWO LEVELS OF CURVED WOOD PIECES IS SPANNED WITH NAILED CANES, WHICH ARE PLASTERED OVER.

IC-12

THIS OPENING IS LOCATED ON THE QUINCHA PILLAR AT THE SPRING POINT OF THE TRANSVERSE ARCH. THESE TRANSVERSE ARCHES ARE FORMED BY PAIRS OF WOODEN ARCHES, WITH WOODEN BATTENS SPANNING BETWEEN THEM. THE CANES ARE ATTACHED TO THESE BATTENS.

True scale when printed on 8-1/2" x 11" sheet.

<b>SEISMIC RETROFITTING PROJECT</b> The Earthen Architecture Initiative 	Building:	CATHEDRAL OF ICA Ica, Perú	Drafted By: William Sarmiento	Date: October 2011
	Sheet Title:	Structural Prospections IC-11 and IC-12	Supervisor: Arch. Mirna Soto	Scale: As noted
			Facilitator: Universidad Católica Sedes Sapientiae	Sheet No.:
			Edited and Translated By: Jabdiel Zapata	<b>IC-P-12</b>

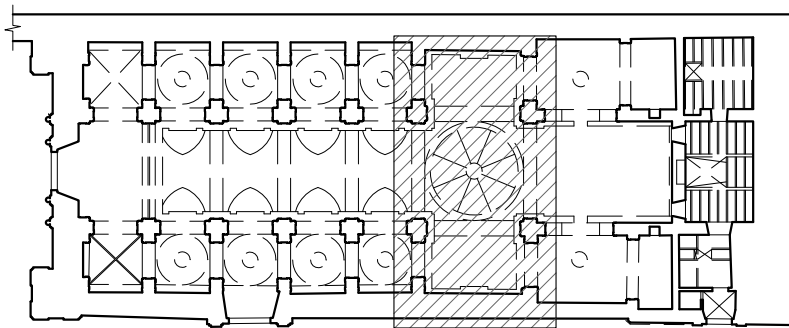

REFERENCE PLAN  
NO SCALE

TRANSEPT AND DOME

## TRANSEPT AND DOME STRUCTURE

NO SCALE

True scale when printed on 8-1/2" x 11" sheet.

**SEISMIC RETROFITTING PROJECT**  
The Earthen Architecture Initiative



The Getty Conservation Institute



Building: **CATHEDRAL OF ICA**  
Ica, Perú

Sheet Title: **Structural Scheme**  
**Transept and Dome**

Drafted By:  
William Sarmiento

Supervisor:  
Arch. Mirna Soto

Facilitator:  
Universidad Católica Sedes Sapientiae

Edited and Translated By:  
Jabdiel Zapata

Date:  
October 2011

Scale:  
As Noted

Sheet No.:

**IC-P-13**



### STRUCTURAL SCHEME - TRANSEPT, DETAIL

THIS OPENING IS LOCATED BETWEEN THE SMALL DOMES OF THE SIDE AISLE AND THE BARREL VAULT WHICH COVERS THE TRANSEPT. FROM TOP TO BOTTOM THERE IS FIRST A LAYER OF LIME, SAND, AND POSSIBLY CEMENT MORTAR OVER A LAYER OF DRIED MUD OVER A LAYER OF FIRED BRICK BONDED WITH A MUD MORTAR. THE BOTTOM LAYER IS A WOOD DECK NAILED TO THE BEAMS THAT FORM THE INTERNAL STRUCTURE. THIS INTERNAL STRUCTURE CONSISTS OF A SILL BEAM, SPANNING BETWEEN PILLARS, WHICH SUPPORTS THE ARCHES THAT GIVE SHAPE TO THE INTERIOR OF THE TRANSEPT AND SIDE AISLE.

True scale when printed on 8-1/2" x 11" sheet.

**SEISMIC RETROFITTING PROJECT**  
The Earthen Architecture Initiative



The Getty Conservation Institute



Building: **CATHEDRAL OF ICA**  
Ica, Perú

Sheet Title: **Structural Scheme**  
**Transept**

Drafted By:  
William Sarmiento

Supervisor:  
Arch. Mirna Soto

Facilitator:  
Universidad Católica Sedes Sapientiae

Edited and Translated By:  
Jabdiel Zapata

Date:  
October 2011

Scale:  
As Noted

Sheet No.:

**IC-P-14**

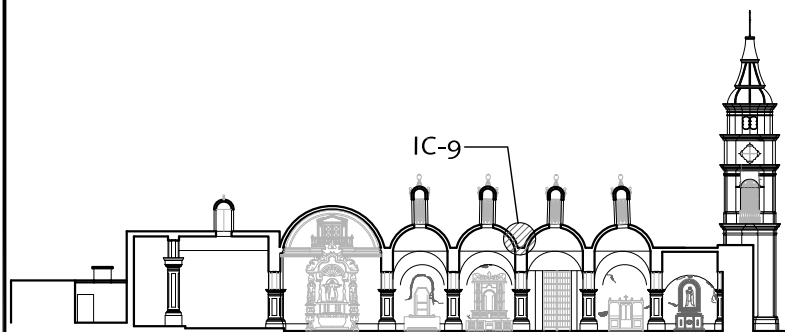

**REFERENCE SECTION**

NO SCALE

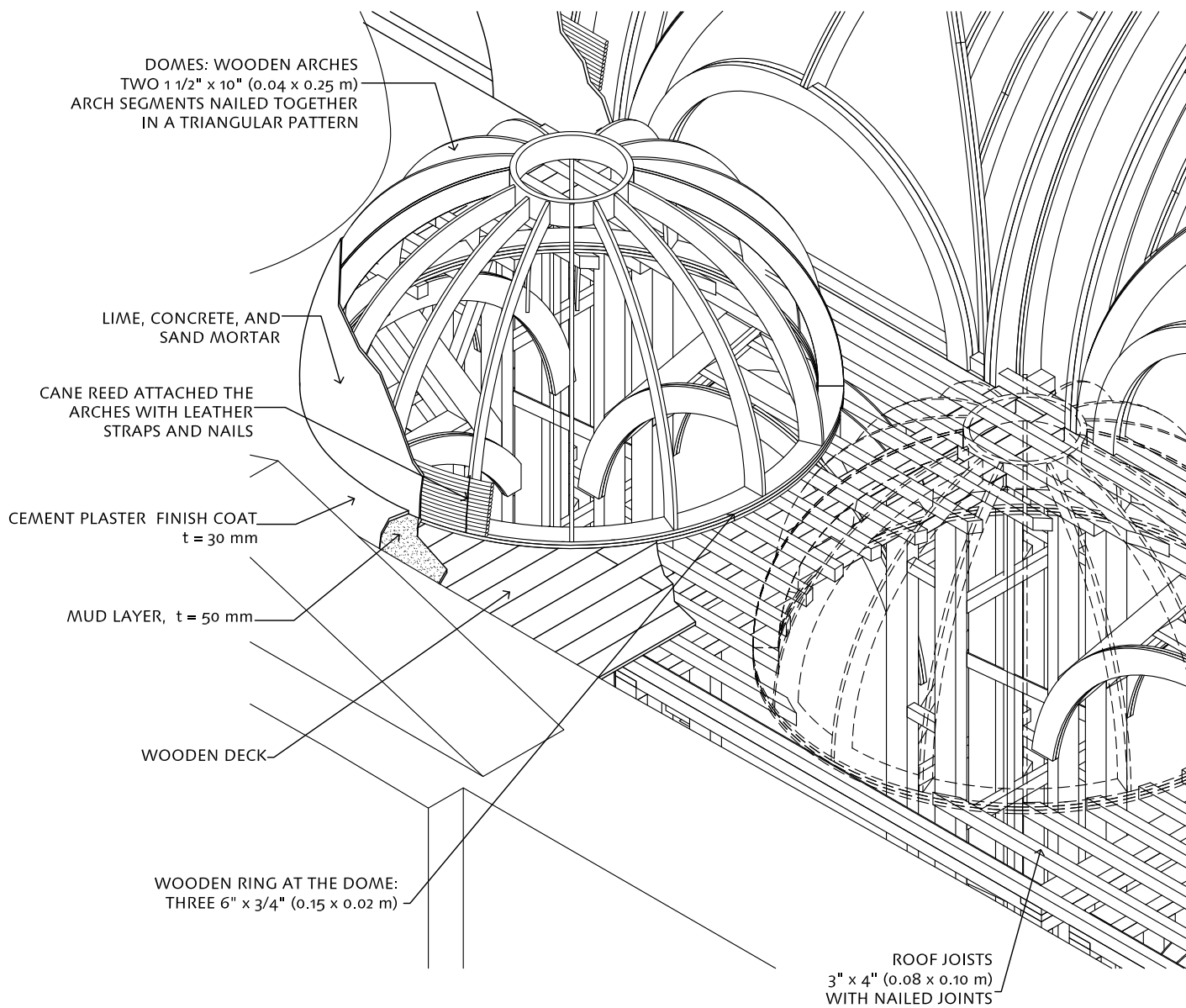

**IC-9**  
SCALE 1:50

True scale when printed on 8-1/2" x 11" sheet.

**SEISMIC RETROFITTING PROJECT**  
The Earthen Architecture Initiative



The Getty Conservation Institute



Building: **CATHEDRAL OF ICA**  
Ica, Perú

Sheet Title: **Structural Prospection**  
IC-9

Drafted By:  
William Sarmiento

Supervisor:  
Arch. Mirna Soto

Facilitator:  
Universidad Católica Sedes Sapientiae

Edited and Translated By:  
Jabdiel Zapata

Date:  
October 2011

Scale:  
As Noted

Sheet No.:  
**IC-P-15**



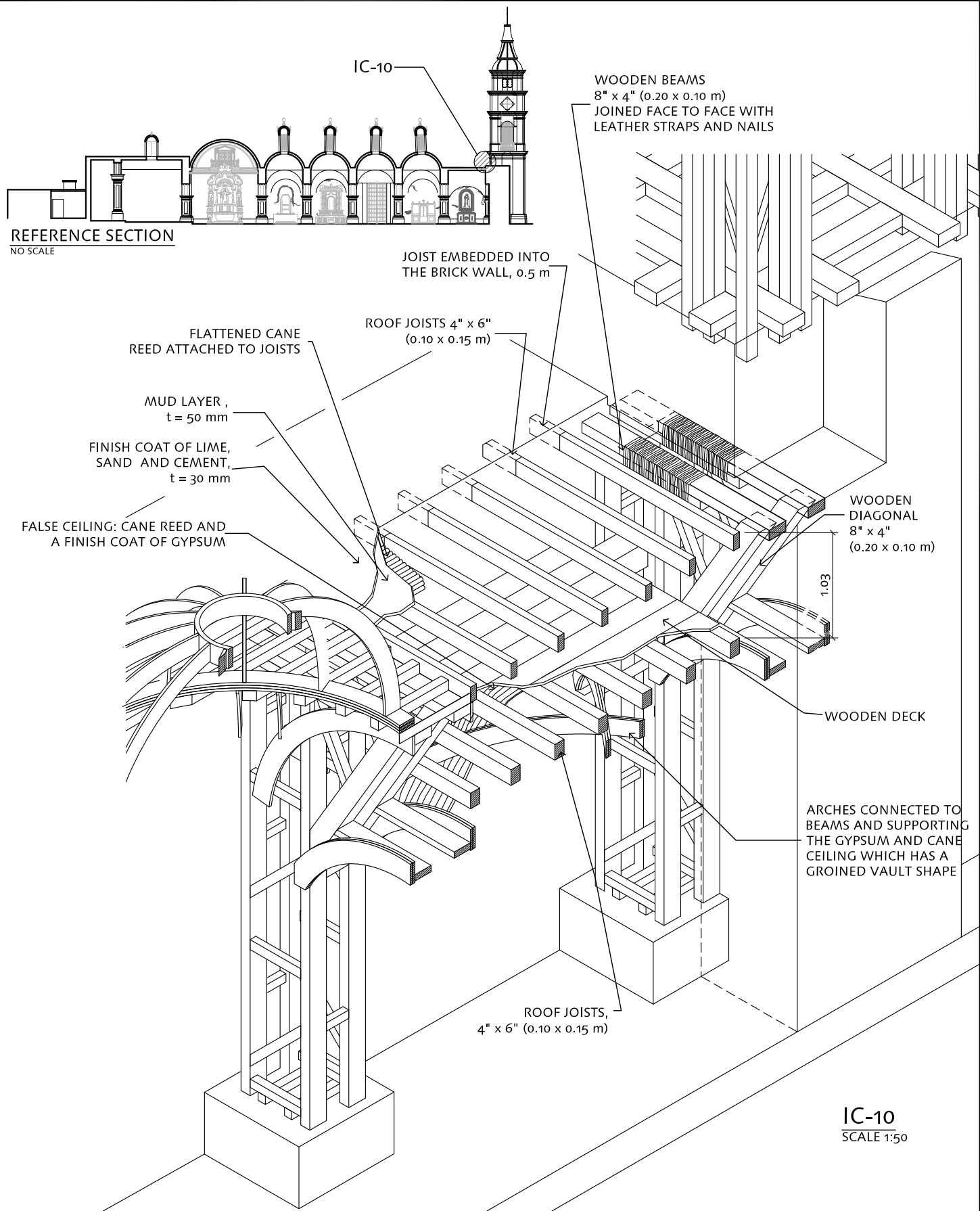

True scale when printed on 8-1/2" x 11" sheet.

**SEISMIC RETROFITTING PROJECT**  
The Earthen Architecture Initiative



Building: **CATHEDRAL OF ICA**  
Ica, Perú

Sheet Title: **Structural Prospection**  
IC-10

Drafted By: **William Sarmiento**

Supervisor: **Arch. Mirna Soto**

Facilitator: **Universidad Católica Sedes Sapientiae**

Edited and Translated By: **Jabdiel Zapata**

Date: **October 2011**

Scale: **As Noted**

Sheet No.: **IC-P-16**



IC-9



IC-10

IC-9

AT THIS OPENING LOCATED ON THE ROOF, IN BETWEEN THE SMALL DOMES, WE OBSERVED MULTIPLE MATERIAL LAYERS. THE FIRST LAYER IS A MORTAR COMPOSED OF LIME, SAND AND PROBABLY CEMENT. THE SECOND LAYER IS MADE OF CLAY, THE THIRD LAYER IS BRICK SET IN MUD, AND THE FINAL LAYER IS WOOD DECKING NAILED TO A BEAM SYSTEM WHICH CORRESPONDS TO THE INTERNAL STRUCTURE.

IC-10

THIS OPENING IS LOCATED ON THE ROOF AT THE INTERNAL CORNER OF THE BASE OF THE BELL TOWER. THERE ARE TWO WOOD BEAMS SET INTO THE WALL OF THE LATERAL FACADE WHICH ARE TIED WITH LEATHER STRAPS TO OTHER BEAMS BELOW, IN ORDER TO INCREASE THE LENGTH AND SPAN OF THE BEAMS. ABOVE THESE BEAMS ARE WOOD BOARDS WHOSE ENDS SUPPORT THE BELL TOWER WALL.

THIS OPENING ALSO ALLOWS ONE TO SEE THE ROOF STRUCTURE AT THIS END OF THE NAVE AND SIDE AISLES. THE FIRST LAYER IS A MORTAR CONSISTING OF LIME, SAND AND PROBABLY CEMENT, AND THE SECOND LAYER IS A MIX OF MUD AND FLATTENED CANE REEDS OVER WOOD JOISTS WITH ENDS EMBEDDED IN THE FRONT FAÇADE. THERE IS ALSO A VOID UNDER THE FRAMING, ABOUT 1 M HIGH, SEPARATING THE STRUCTURE FROM THE FALSE CEILING. FROM TOP TO BOTTOM THIS STRUCTURE IS COMPOSED OF THE FOLLOWING: WOOD BOARDS ON TOP OF WOOD JOISTS; ARCHES WHICH FORM THE GROIN VAULT AND HANG FROM THE WOOD JOISTS; AND CANES, NAILED UNDERNEATH AND LATER COATED WITH GYPSUM PLASTER.

True scale when printed on 8-1/2" x 11" sheet.

**SEISMIC RETROFITTING PROJECT**  
The Earthen Architecture Initiative



The Getty Conservation Institute



Building:

CATHEDRAL OF ICA  
Ica, Perú

Sheet Title:

Structural Prospections  
IC-9 and IC-10

Drafted By:

William Sarmiento

Supervisor:

Arch. Mirna Soto

Facilitator:

Universidad Católica Sedes Sapientiae

Edited and Translated By:

Jabdiel Zapata

Date:

October 2011

Scale:

-

Sheet No.:

IC-P-17

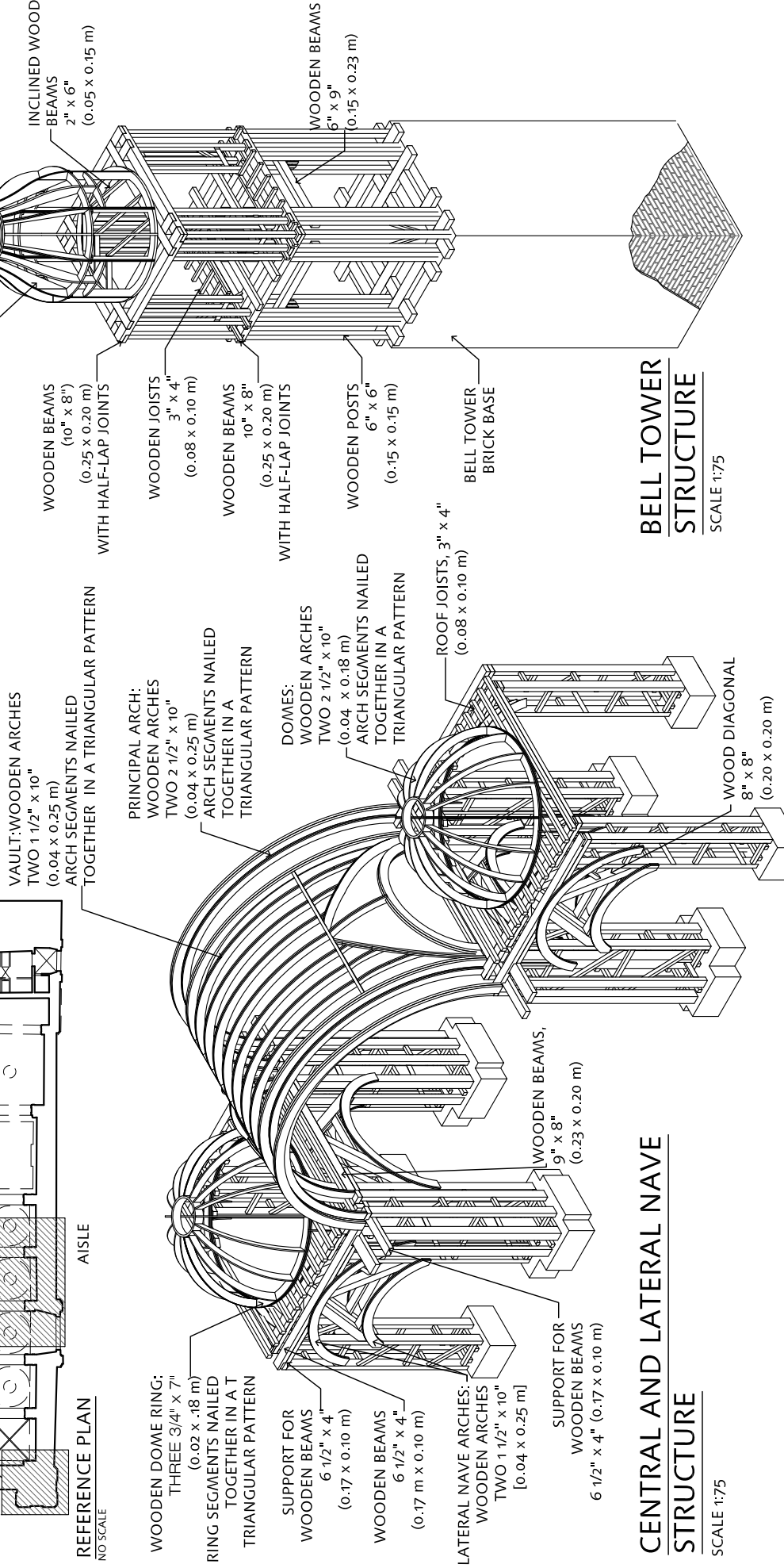
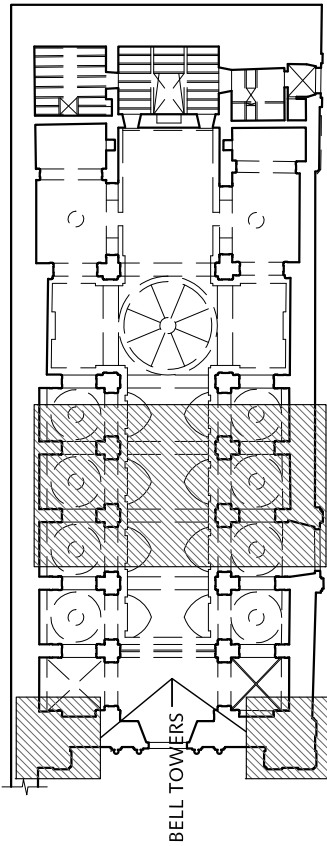

**CENTRAL AND LATERAL NAVE STRUCTURE**  
SCALE 1:75

**BELL TOWER STRUCTURE**  
SCALE 1:75

**SEISMIC RETROFITTING PROJECT**  
The Earthen Architecture Initiative

The Getty Conservation Institute

UNIVERSITY OF BATH

PERUVIANA UNIVERSIDAD CATOLICA DEL SACRAMENTO

Building: CATHEDRAL OF ICA  
Ica, Perú

Structural Scheme  
Central Nave, Side Aisles, and Bell Tower

Sheet Title:

Drafted By: William Sarmiento

Supervisor: Arch. Mirna Soto

Facilitator: Universidad Católica Sedes Sapientiae

Edited and Translated By: Jabdriel Zapata

Date: October 2011

Scale: As noted

Sheet No.: IC-P-18



BELL TOWER

True scale when printed on 8-1/2" x 11" sheet.

**SEISMIC RETROFITTING PROJECT**  
The Earthen Architecture Initiative



The Getty Conservation Institute



PONTIFICIA  
UNIVERSIDAD  
CATÓLICA  
DEL PERÚ

Building:  
**CATHEDRAL OF ICA**  
Ica, Perú

Sheet Title:  
**Structural Scheme**  
Bell Tower

Drafted By:  
William Sarmiento

Supervisor:  
Arch. Mirna Soto

Facilitator:  
Universidad Católica Sedes Sapientiae

Edited and Translated By:  
Jabdiel Zapata

Date:  
October 2011

Scale:  
As Noted

Sheet No.:

**IC-P-19**





CHOIR LOFT

True scale when printed on 8-1/2" x 11" sheet.

**SEISMIC RETROFITTING PROJECT**  
The Earthen Architecture Initiative



The Getty Conservation Institute



PONTIFICIA  
UNIVERSIDAD  
CATÓLICA  
DEL PERÚ

Building:

CATHEDRAL OF ICA  
Ica, Perú

Drafted By:  
William Sarmiento

Date:  
October 2011

Supervisor:  
Arch. Mirna Soto

Scale:  
As noted

Sheet Title:

Structural Prospections  
Choir Loft

Facilitator:  
Universidad Católica Sedes Sapientiae

Sheet No.:

Edited and Translated By:  
Jabdiel Zapata

IC-P-21

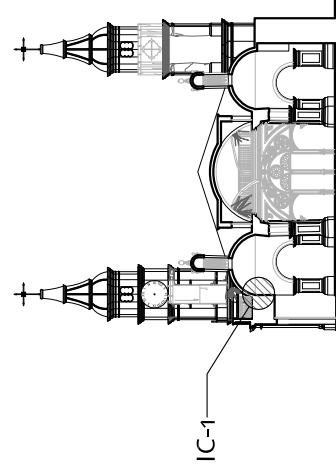

REFERENCE SECTION  
NO SCALE

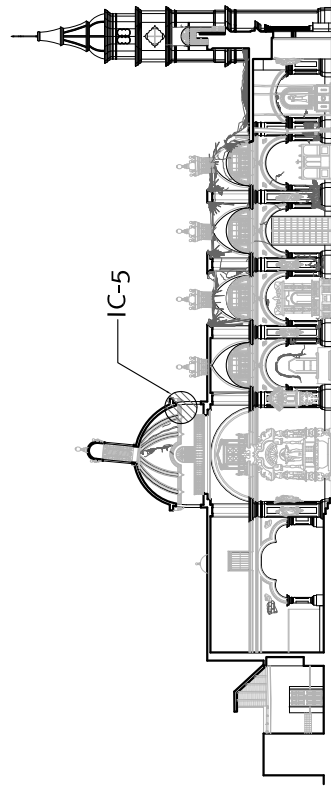

REFERENCE SECTION  
NO SCALE

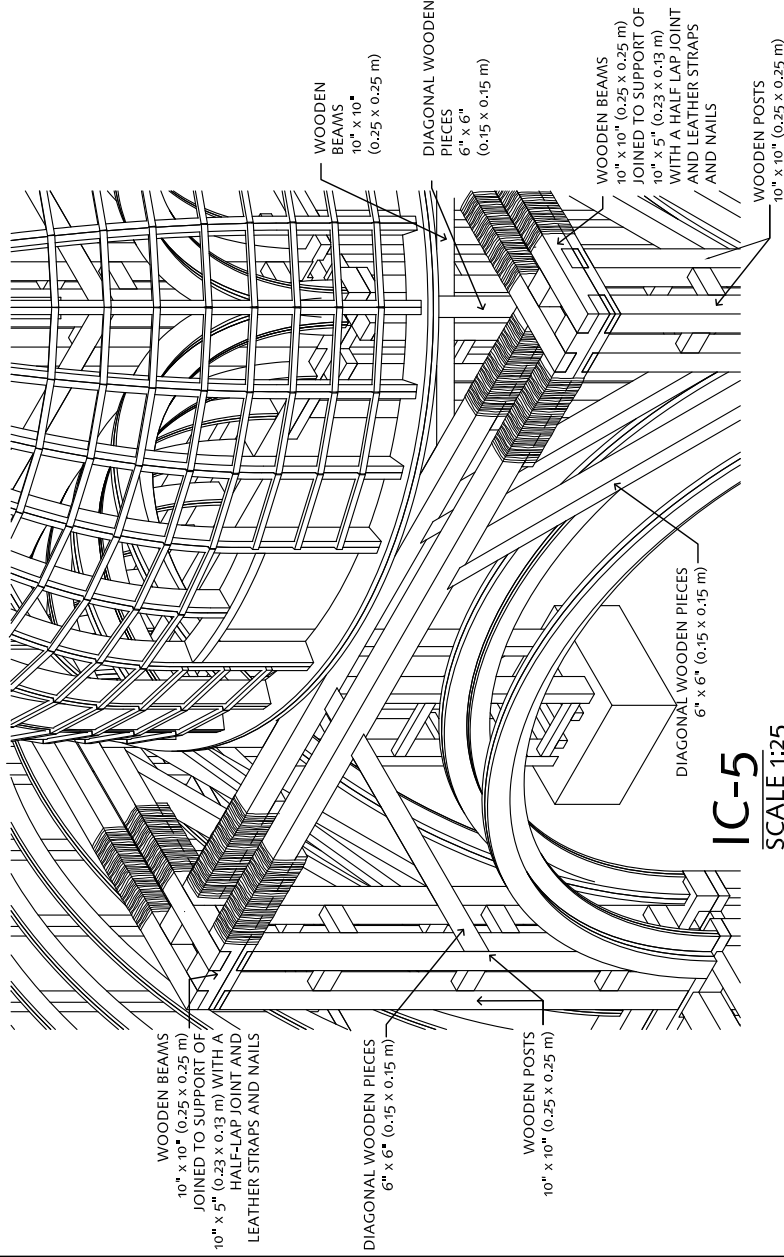
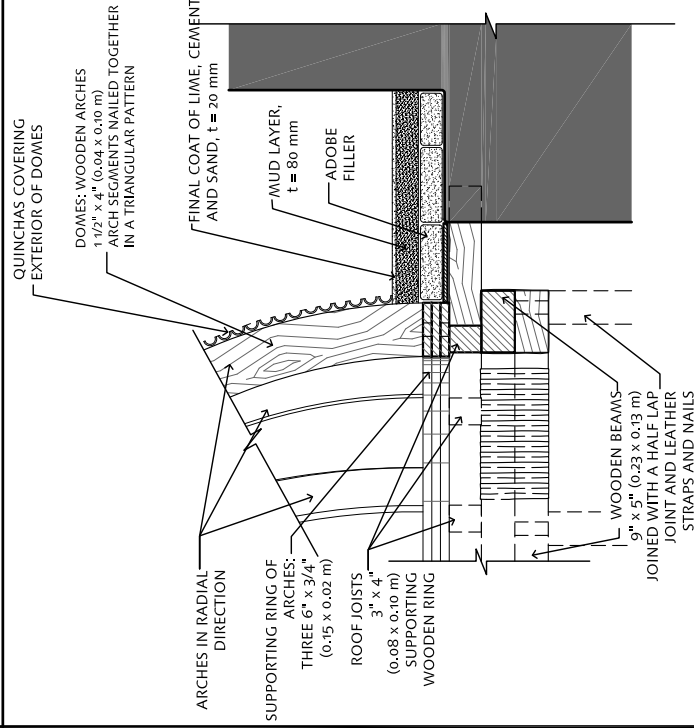

**SEISMIC RETROFITTING PROJECT**  
The Earthen Architecture Initiative



Building:

CATHEDRAL OF ICA  
Ica, Perú

Sheet Title:

Structural Prospections  
IC-1 and IC-5

Drafted By:  
William Sarmiento

Supervisor:  
Arch. Mirna Soto

Facilitator:  
Universidad Católica Sedes Sapientiae  
Edited and Translated By:  
Jabdiel Zapata

Date:  
October 2011

Scale:  
As noted

Sheet No.:

IC-P-22



IC-1



IC-5

### IC-1

THIS OPENING CONFIRMED ONCE AGAIN THAT THE STRUCTURAL SYSTEM OF THE CHURCH IS COMPRISED OF POSTS AND BEAMS. THE JOINED BEAMS AT THE TOP OF PILLARS FORM SQUARE FRAMES WHICH SUPPORT BEAMS AND RINGS THAT SUPPORT THE SMALL DOMES. ALSO THE PORTAL AT THE NORTH LATERAL WALL IS STRUCTURALLY INDEPENDENT FROM THE ADJACENT WALLS. THE ROOF BEAM RUNS PARALLEL TO, BUT AWAY FROM, THE WALL; HOWEVER, DEPENDING ON THE DEPTH OF THE CEILING JOISTS, SOME OF THEM ARE EMBEDDED IN THE WALL TO SUPPORT THE ENDS OF THE CANES OR DECKING COVERING THIS SPACE.

### IC-5

THIS OPENING SHOWS THE BASE OF THE TRANSEPT DOME AND CONFIRMS IT IS A POST-AND-BEAM SYSTEM. THE PILLARS ARE CONSTRUCTED WITH FOUR WOOD POSTS THAT SUPPORT THE DOUBLE BEAMS, WHICH ARE REINFORCED AT THE ENDS WITH OTHER WOOD BEAMS TO INCREASE THEIR DEPTH AND ARE JOINED WITH LEATHER STRAPS.

THE BEAMS CREATE A SQUARE FRAME REINFORCED WITH DIAGONAL WOOD MEMBERS AT THE CORNERS. THE WOOD RING AT THE BASE OF THE DOME IS SUPPORTED AT THE CENTER OF EACH SIDE OF THE SQUARE FRAME AND ALSO BY THE DIAGONAL REINFORCING MEMBERS.

True scale when printed on 8-1/2" x 11" sheet.

**SEISMIC RETROFITTING PROJECT**  
The Earthen Architecture Initiative



The Getty Conservation Institute



Building:

**CATHEDRAL OF ICA**  
Ica, Perú

Sheet Title:

**Structural Prospections**  
IC-1 and IC-5

Drafted By:

William Sarmiento

Supervisor:

Arch. Mirna Soto

Facilitator:

Universidad Católica Sedes Sapientiae

Edited and Translated By:

Jabdiel Zapata

Date:

October 2011

Scale:

-

Sheet No.:

**IC-P-23**



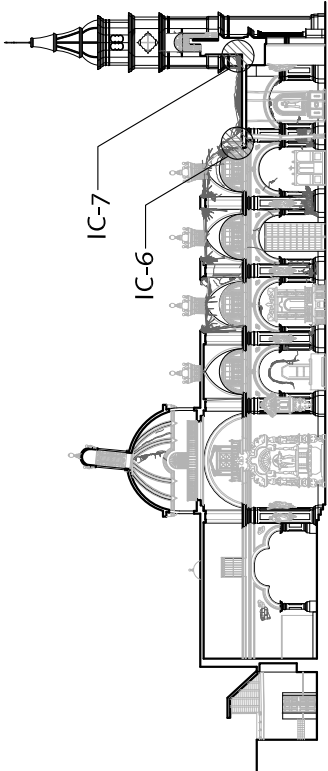

REFERENCE SECTION  
NO SCALE

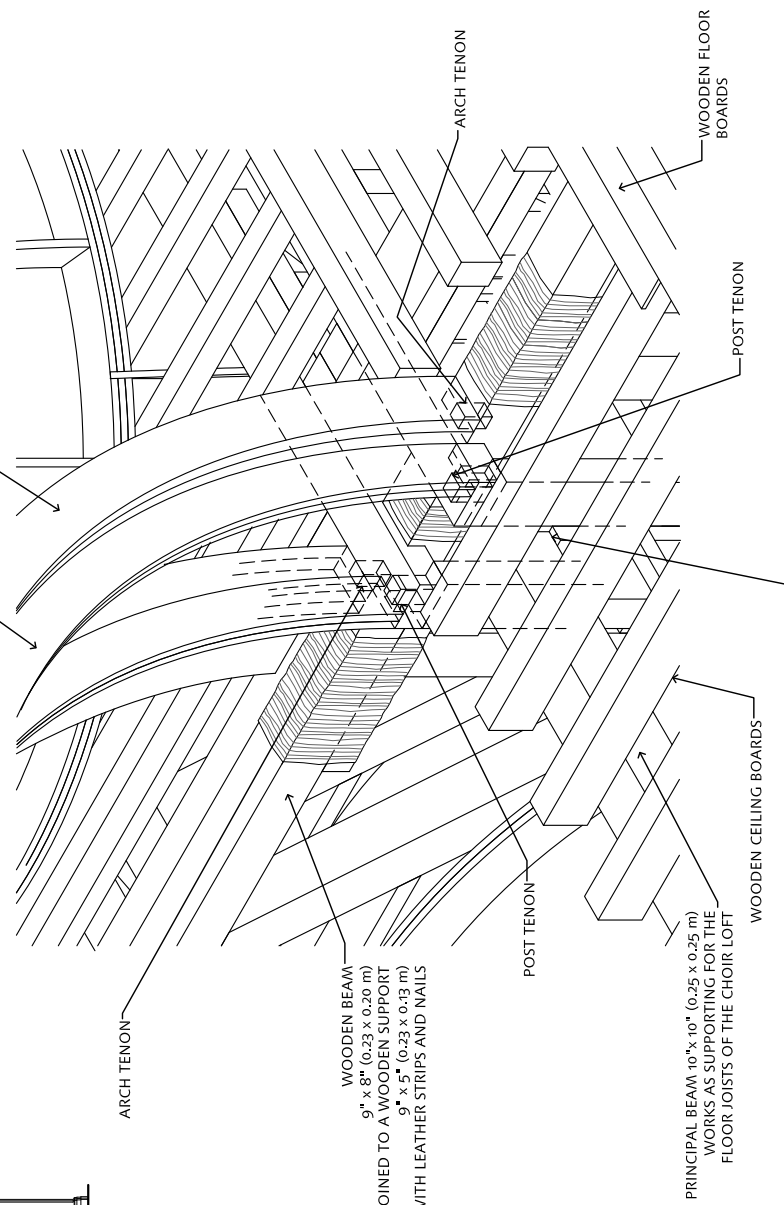

PRINCIPAL ARCH: ADDITIONAL WOODEN ARCHES AT RIBS  
TWO 1 3/4" x 10" (0.04 x 0.25 m)  
ARCH SEGMENTS NAILED TOGETHER  
IN A TRIANGULAR PATTERN

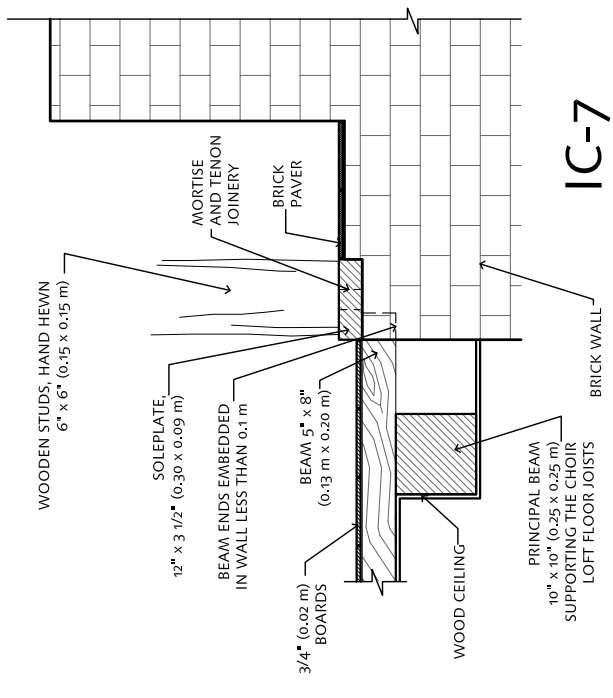

IC-6  
SCALE 1:10



IC-7  
SCALE 1:10

<b>SEISMIC RETROFITTING PROJECT</b> The Earthen Architecture Initiative	Building: <b>CATHEDRAL OF ICA</b> Ica, Peru	Drafted By: William Sarmiento	Date: October 2011
		Supervisor: Arch. Mirna Soto	Scale: As noted
The Getty Conservation Institute  	Sheet Title: <b>Structural Prospections</b> IC-6 and IC-7	Facilitator: Universidad Católica Sedes Sapientiae	Sheet No.: <b>IC-P-24</b>
		Edited and Translated By: Jabdriel Zapata	



IC-6



IC-7



IC-7

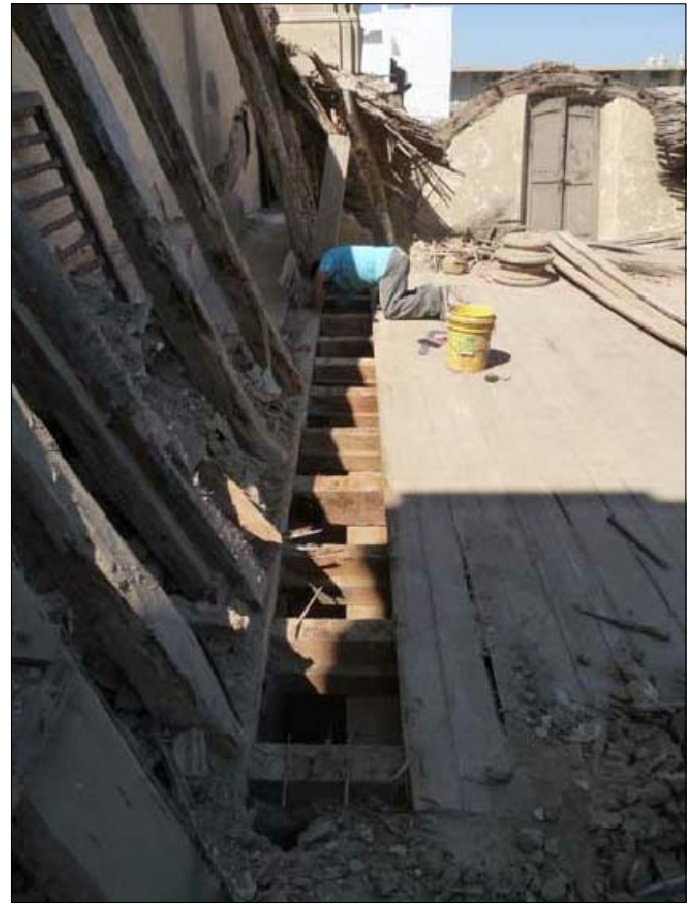

IC-7

### IC-6

THIS OPENING SHOWS THE CONNECTION BETWEEN THE TRANSVERSE ARCHES AND THE TOP OF WALL THAT SEPARATES THE NAVE FROM THE SIDE AISLES. ONE CAN SEE THE CONNECTION OF THE FOUR MAIN POSTS WHICH FORM THE QUINCHA PILLAR. THESE POSTS ARE CONNECTED TO A BEAM ABOVE, WHICH HAS BEEN DEEPEINED BY ADDING ANOTHER PIECE OF WOOD BELOW IT. IN ORDER TO SECURE THE PIECE OF WOOD BELOW, LEATHER (BEEF OR LAMB SKIN) STRAPS HAVE BEEN TIED AROUND THE TOP OF THE BEAM. OTHER BEAMS, RUNNING PERPENDICULAR TO THE DOUBLE BEAMS AND EXTENDING FROM SIDE AISLES, ARE ALSO CONNECTED TO THE DOUBLE BEAMS. ALL ASSEMBLIES CONSIST OF WOOD COMPONENTS AND ARE CONNECTED BY MORTISE-AND-TENON JOINTS. ON THE BEAMS, THERE ARE MORTISES THAT RECEIVE THE TENONS OF THE PRIMARY AND SECONDARY ARCHES OF THE NAVE VAULT. THE PRIMARY ARCH IS COMPOSED OF AN ARCH WITH THE SAME RADIUS AS THE SECONDARY ARCHES AT THE VAULT. AN ADDITIONAL SET OF WOOD ARCHES, WITH A SMALLER RADIUS, HANGS BELOW THE PRIMARY ARCH TO CREATE THE "RIBS" THAT PROJECT BELOW THE MAIN CEILING PLANE OF THE BARREL VAULT.

### IC-7

THIS OPENING SHOWS THE STRUCTURE OF THE CHOIR LOFT. IT HAS TWO LARGE 10" x 10" (0.25 x 0.25 m) WOOD BEAMS WITH A LENGTH CORRESPONDING TO THE WIDTH OF THE NAVE. THEIR ENDS ARE SUPPORTED BY THE QUINCHA PILLARS. ONE OF THESE BEAMS IS LOCATED NEAR TO THE ENTRANCE WALL AND THE OTHER IS LOCATED AT THE EDGE OF THE CHOIR LOFT, ADJACENT TO THE NAVE. THESE BEAMS SUPPORT 5" x 8" (0.13 x 0.20 m) JOISTS WHICH HAVE A VERY SMALL EMBEDMENT (LESS THAN 0.10 m) OR NONE AT ALL. ABOVE THESE BEAMS IS THE DECKING WHICH IS THE FLOOR FOR THE CHOIR LOFT. BELOW THIS FRAMING THERE IS A WOODEN CEILING. ONE CAN ALSO SEE AT THE ENTRANCE FACADE WALL THE PRESENCE OF A 12" x 3.5" (0.31 x 0.09 m) PLATE THAT SUPPORTED THE VERTICAL POSTS AND ARCHES THAT FORM THE EAST END OF THE BARREL VAULT, WHICH WAS ORIGINALLY SEPARATED FROM THE PEDIMENT OF THE BRICK ENTRANCE FACADE. THE ARCH IS PRESENTLY UNSTABLE AND RESTS AGAINST THE PEDIMENT WALL.

**SEISMIC RETROFITTING PROJECT**  
The Earthen Architecture Initiative



The Getty Conservation Institute



Building:

CATHEDRAL OF ICA  
Ica, Perú

Sheet Title:

Structural Prospections  
IC-6 and IC-7

Drafted By:

William Sarmiento

Supervisor:

Arch. Mirna Soto

Facilitator:

Universidad Católica Sedes Sapientiae

Edited and Translated By:

Jabdiel Zapata

Date:

October 2011

Scale:

-

Sheet No.:

IC-P-25

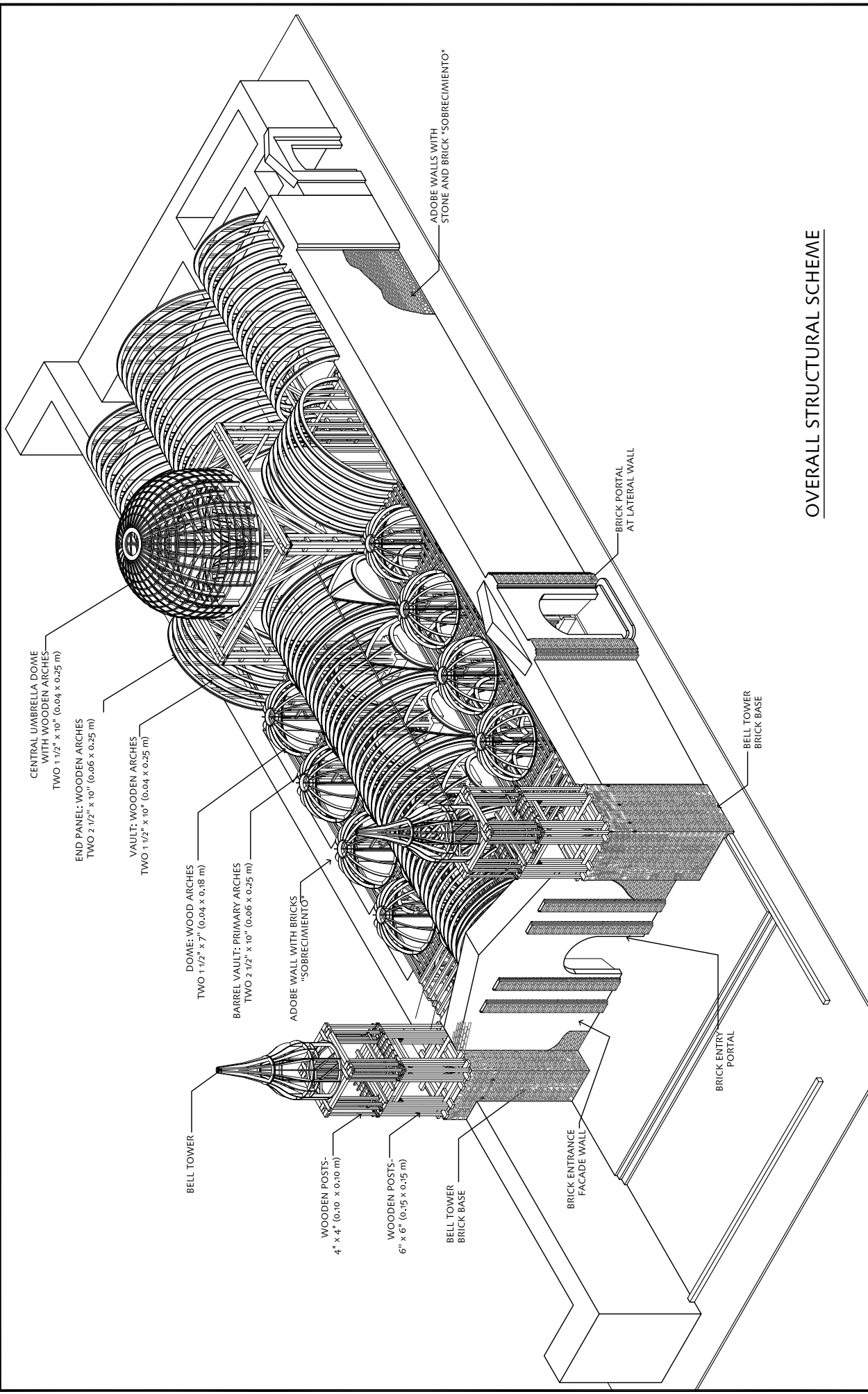

**OVERALL STRUCTURAL SCHEME**

<p><b>SEISMIC RETROFITTING PROJECT</b> The Earthen Architecture Initiative</p> <p><b>The Getty Conservation Institute</b></p> <p>UNIVERSITY OF BATH</p> <p>UNIVERSIDAD CATÓLICA DEL PERÚ</p>	<p>Building: <b>CATHEDRAL OF ICA</b> Ica, Perú</p>	<p>Drafted By: <b>William Sarmiento</b></p>	<p>Date: <b>October 2011</b></p>
	<p>Sheet Title: <b>Overall Structural Scheme</b></p>	<p>Supervisor: <b>Arch. Mirna Soto</b></p> <p>Facilitator: <b>Universidad Católica Sedes Sapientiae</b></p> <p>Edited and Translated By: <b>Jabdiel Zapata</b></p>	<p>Scale: <b>As noted</b></p> <p>Sheet No.: <b>IC-P-26</b></p>